

SENCOR®

STM 7651WS
STM 7630RS
STM 7632WP



STAND MIXER GORDON

Translation of the original manual



SENCOR®

**STM 7651WS
STM 7630RS
STM 7632WP**



A

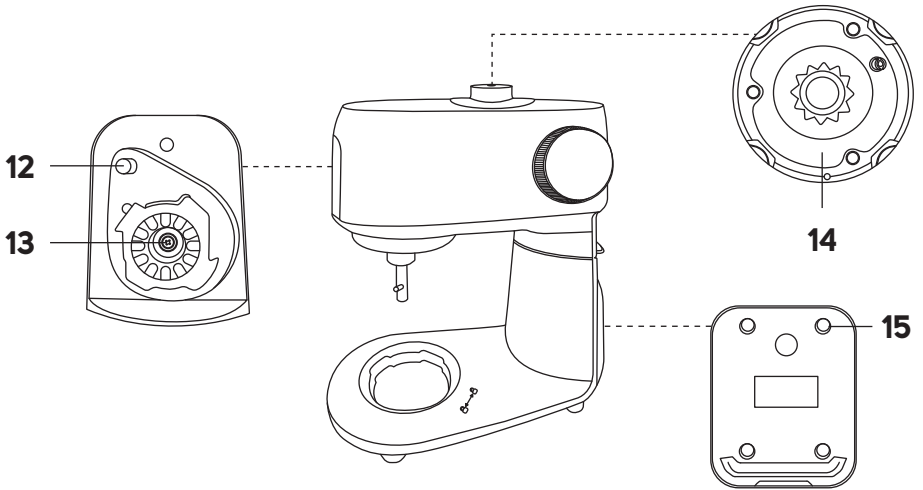
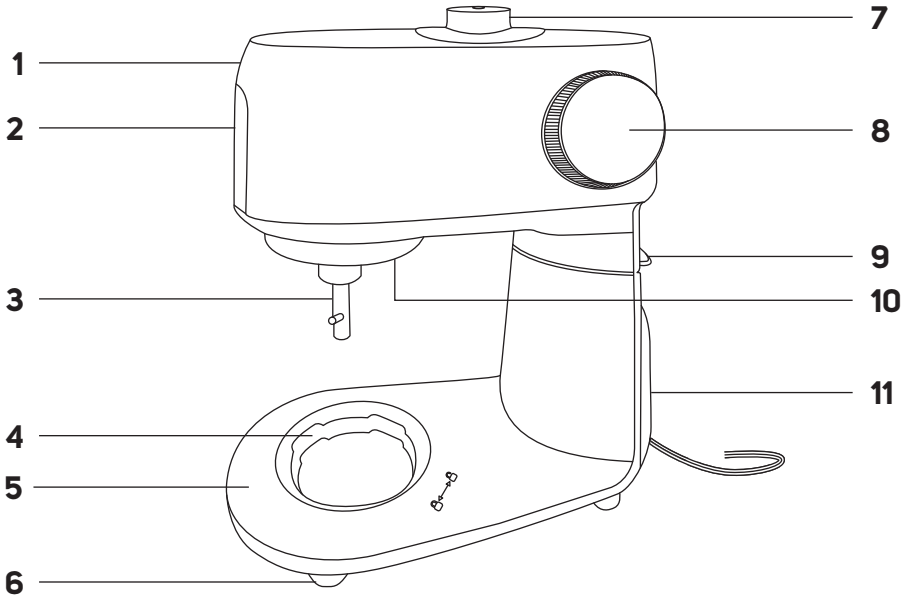

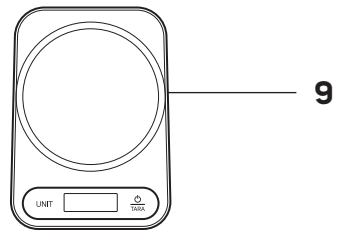
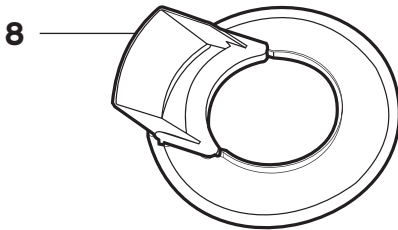
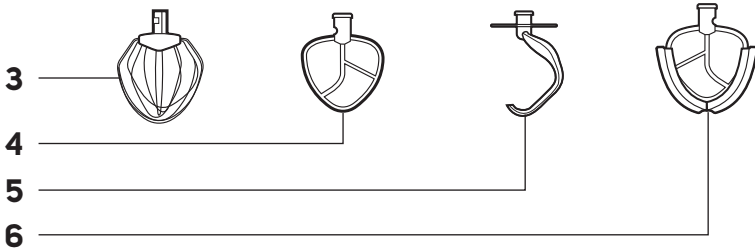
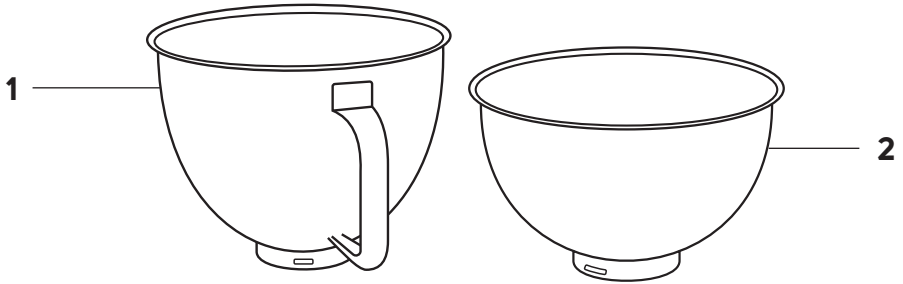
B

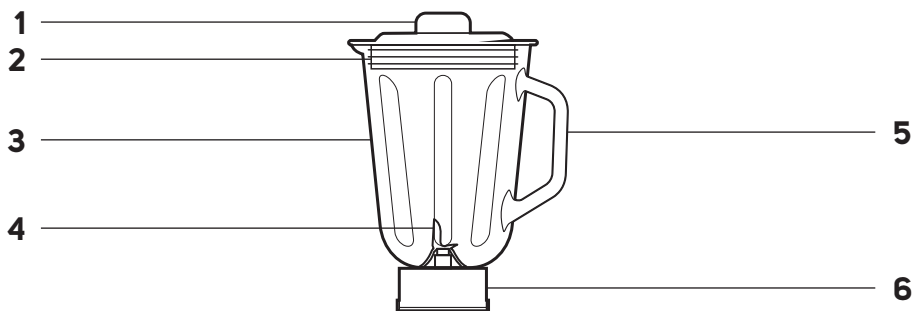
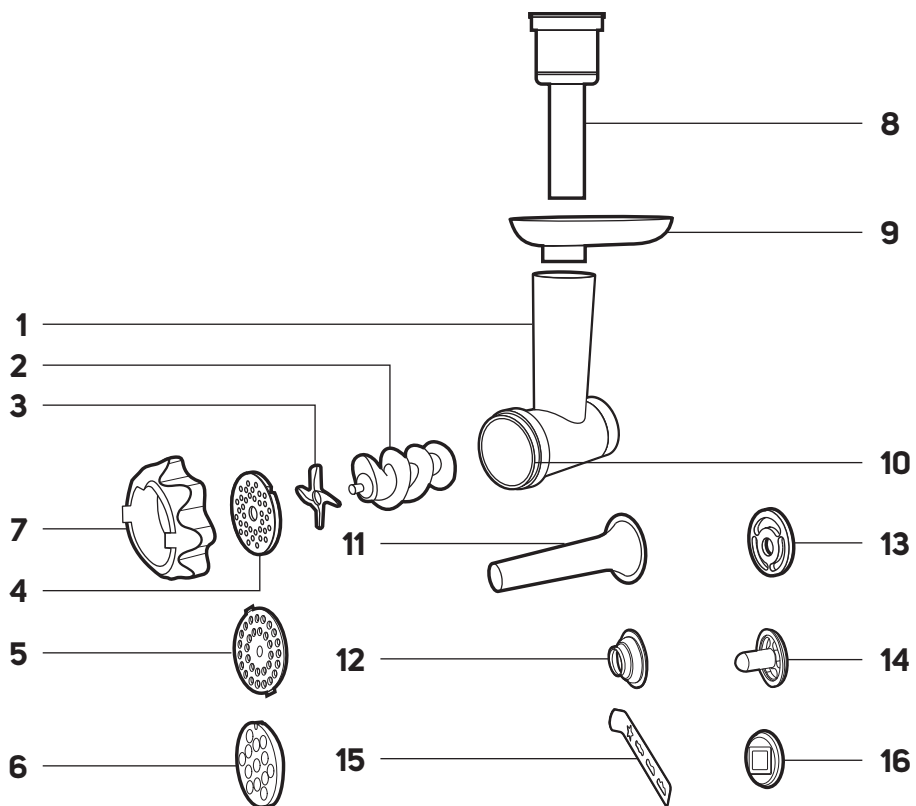
C**D**

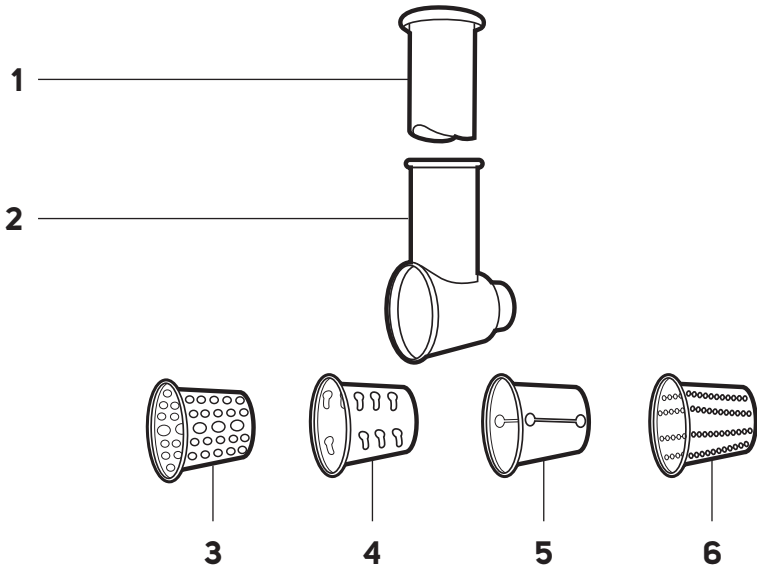
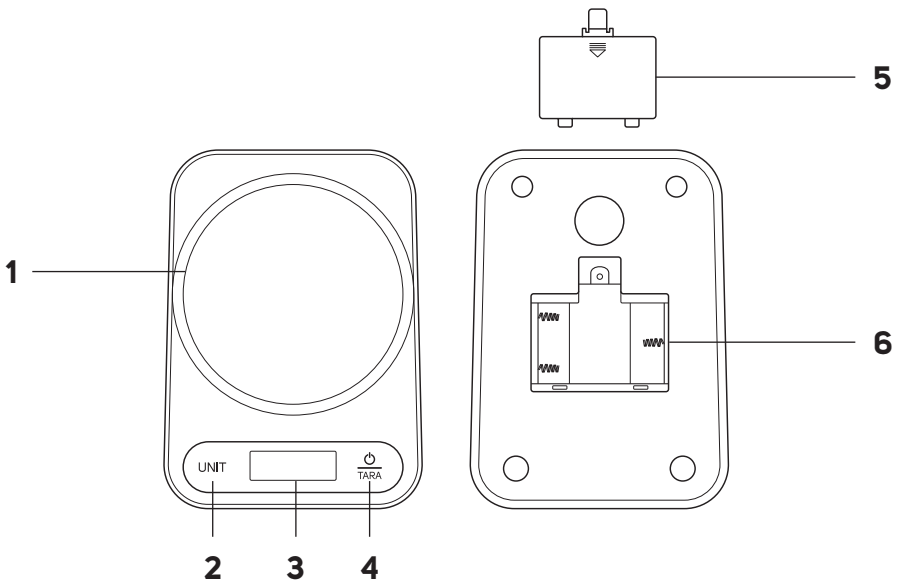
E**F**

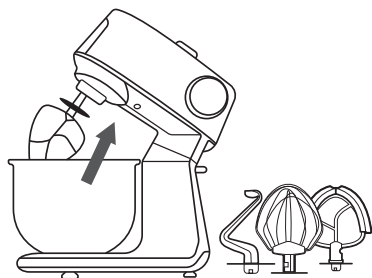
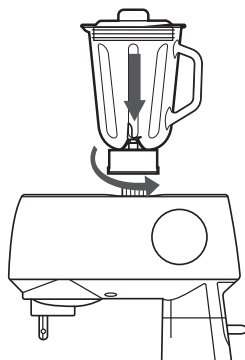
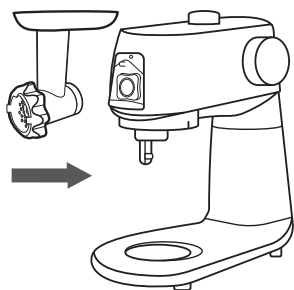
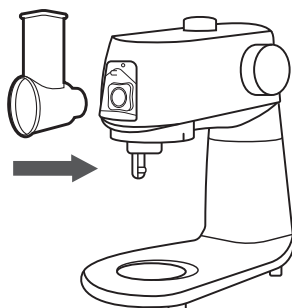
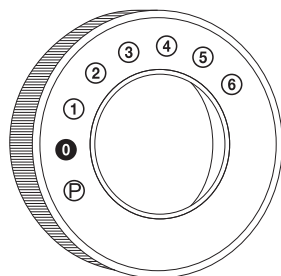
G1**G2****G3****G4****G5**

H1

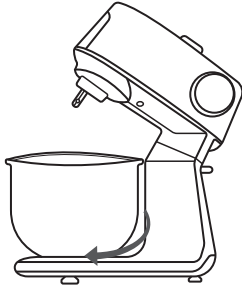

H2

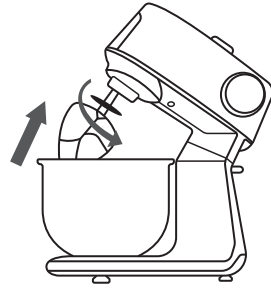

H3

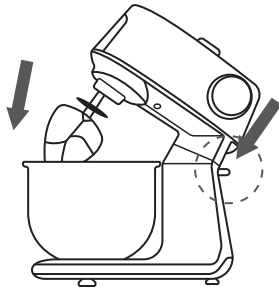

H4

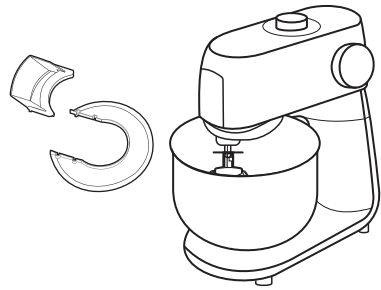

H5

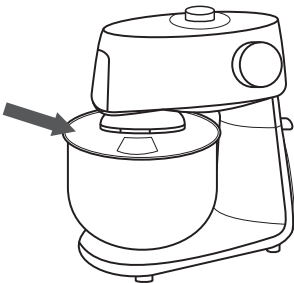

H6

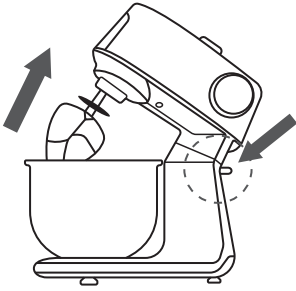

H7

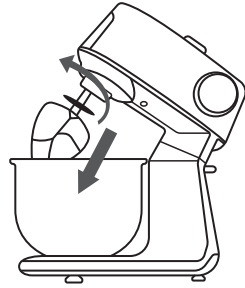

H8

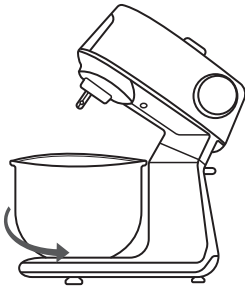

11

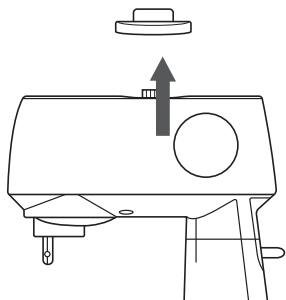

12

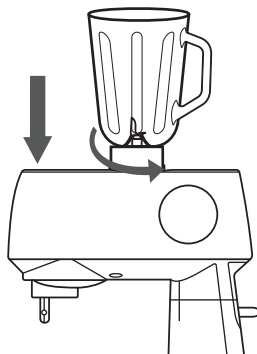

13

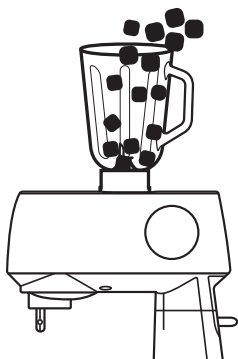

14

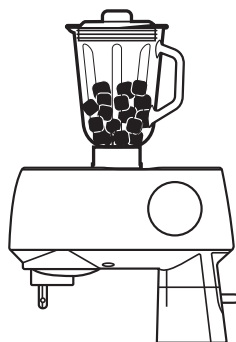

15

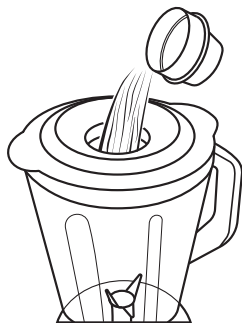

16

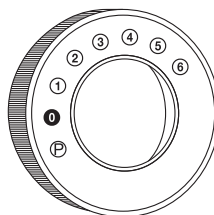

J1

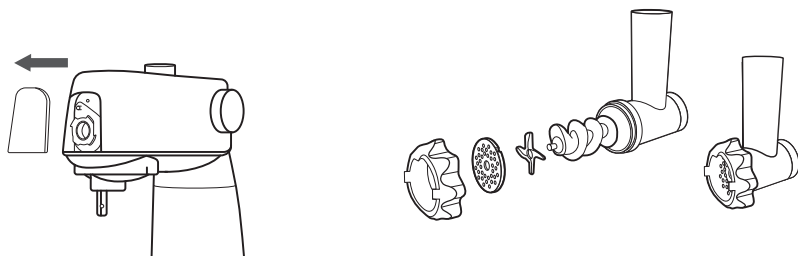

J2

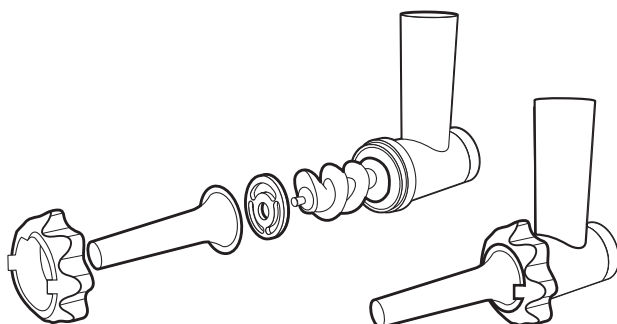

J3

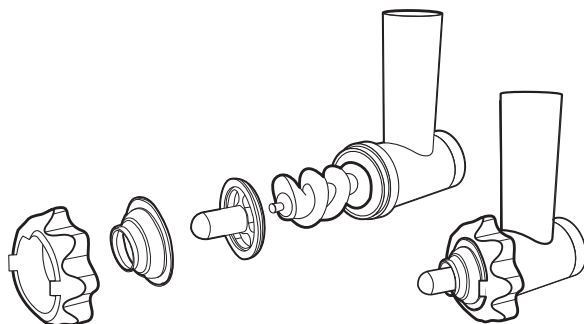

J4

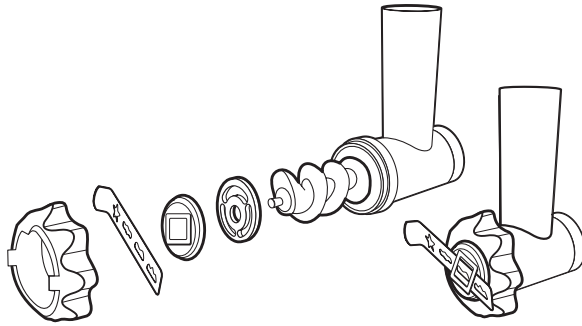

J5

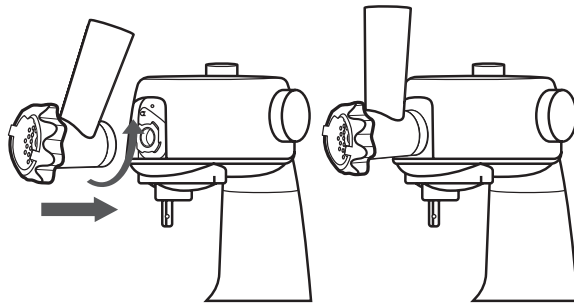

J6

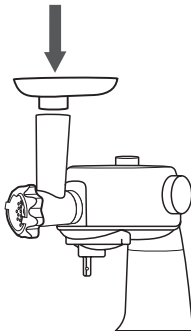

J7

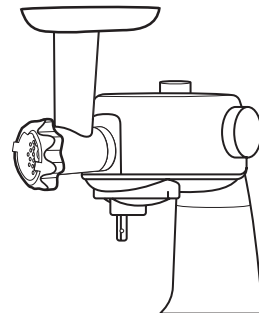

J8

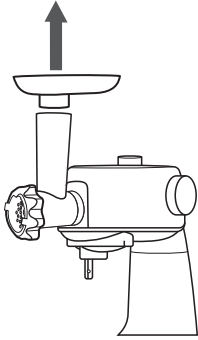

J9

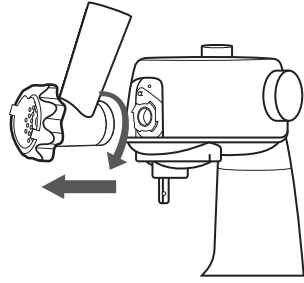

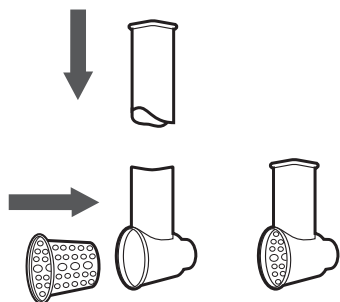
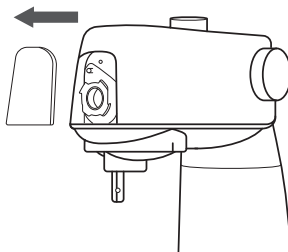
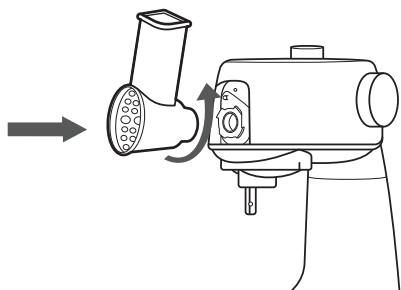
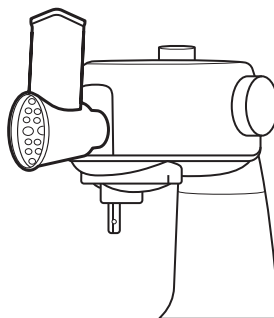
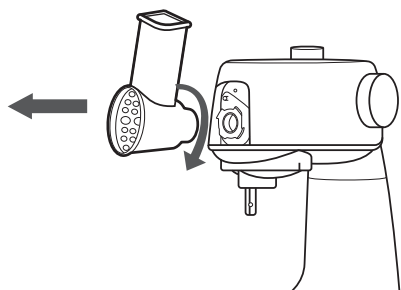
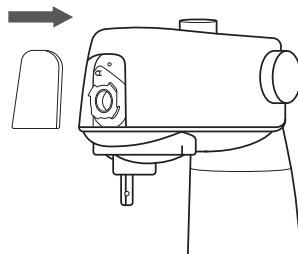
K1**K2****K3****K4****K5****K6**

L

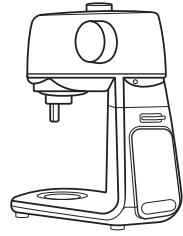
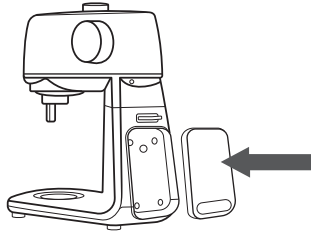
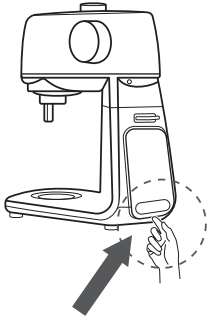

IMPORTANT SAFETY INSTRUCTIONS

READ CAREFULLY AND STORE FOR FUTURE USE.

General Warnings

- This appliance is not to be used by children. Keep this appliance and its power cable out of the reach of children.
- Appliances may be used by persons with reduced physical, sensory or mental abilities or lack of experience and knowledge, provided they are supervised or have been instructed in the safe use of the appliance and understand the potential hazards.
- Children must not play with the appliance.
- Cleaning and maintenance must not be carried out by children.
- If the power cord is damaged, have it replaced in a professional service centre in order to prevent a dangerous situation. Never use the appliance if the power cord is damaged.



Caution:

Incorrect use may lead to injuries.

- Be careful when handling the cutting blades and attachments, especially when removing them from the container, emptying the container and during cleaning.
- Always clean the food contact surfaces of the appliance according to the instructions in this manual.

- Always turn off the appliance and disconnect it from the power socket if you will not be using it and if you will be leaving it without supervision, before assembly, disassembly, cleaning or moving it.
- Before replacing the accessories or accessible movable parts, please turn the appliance off and disconnect it from the power supply.
- Follow the recommended processing times for the ingredients listed in these instructions.

Electrical Safety

- Before connecting the appliance to the mains socket, ensure that the voltage stated on its rating plate matches the voltage in the socket.
- Connect the appliance only to a properly earthed socket. Do not use an extension cord.
- Do not connect or disconnect the appliance power cord to or from the mains socket with wet hands.
- Ensure that the plug of the power cord does not come into contact with water or moisture.
- Do not disconnect the appliance from the mains socket by pulling on the power cord. This could damage the power cord or the mains socket. Disconnect the cable from the socket by pulling on the plug of the power cord.
- Do not place heavy objects on the power cord. Ensure that the power cord does not hang over the edge of the table or touch hot surfaces or sharp objects.
- To avoid the danger of injury by electrical shock, do not repair the appliance yourself or make any adjustments to it. Have all repairs or adjustments of the appliance performed at an authorised service centre. Tampering with the appliance during the warranty period may void the warranty.
- Do not spray the appliance with water or any other liquid. Never wash it under running water or submerge it in water or another liquid.
- Always switch off the appliance and disconnect it from the mains socket when you have finished using it.
- This appliance is not designed to be controlled using a programmed device, external timer switch or remote control.

Proper Use of the Appliance

- The appliance is intended and designed for processing a standard amount of food in the household.
- Do not use the appliance for any purpose other than that for which it is intended.
- This appliance is designed for use in indoor areas only. Never use it in outdoor or industrial environment.
- This appliance must only be used in accordance with the instructions provided in this user's manual.
- Use the appliance only with the original accessories supplied with it.



Caution:

The use of non-original accessories can lead to a dangerous situation.

- Do not use sprays in the vicinity of the appliance.
- Only place the appliance on an even, dry surface. Do not place the appliance on window sills or on unstable surfaces. Also, do not place it on an electric or gas stove or in its vicinity, do not place it in the vicinity of an open fire or an appliance that is a source of heat.
- Do not use the appliance if it malfunctions, has been dropped on the floor, immersed in water or damaged in any way. Take it to an authorised service centre for inspection or repair.
- It is forbidden to modify the surface of the appliance in any way, e.g. using self-adhesive wallpaper, foil, etc.
- Before first use, the accessories should be thoroughly washed with warm water using kitchen detergent, then rinsed with potable water and wiped thoroughly dry with a soft cloth.
- Before putting the appliance into operation, make sure that it is correctly assembled and that the multifunction head is in a horizontal position.
- Do not use the appliance if your hands are wet.
- Do not cover the appliance ventilation openings.
- Do not turn on the appliance when it is empty. Incorrect use of the appliance may negatively affect its lifetime.
- Operate the appliance only after you have immersed the attachments in the food container. While the appliance is in use, keep the attachments submerged in the container to avoid splashing food.
- If food is sticking to the attachments or the inside of the bowl, turn off the appliance and disconnect it from the power socket. Use a spatula to clean the attachments and the sides of the bowl.

- Avoid contact with rotating parts of the appliance. Do not insert your hands, fork or other objects into the ingredient container during use and keep hair, clothing, etc. well away from rotating parts of the appliance. If a fork or other object falls into the container during use, turn the appliance off immediately.
- Ensure that hair, clothing or other objects do not enter the filling opening of the meat grinder or grater during operation. Only place ingredients that are to be processed into the filling opening.
- Never use your fingers or other objects to push ingredients through the filling opening of the meat grinder and grater. For this purpose there is a pusher included as an accessory.
- Do not tilt the multifunction head during operation.
- Take extra care when handling hot liquids and food. Hot steam or splashing hot liquids and food may cause scalding. For increased safety, it is recommended to allow hot liquids and foods to cool before processing.
- If you have been processing hot foods, the removable attachments may become warm after use.
- Before attaching attachments to the appliance, removing or replacing them, ensure that the appliance is turned off and disconnected from the power socket.
- When handling the grinding blade of the meat grinder and the blade unit of the blender, be very careful to avoid injury from the edges. Extra attention must be paid when emptying the blender container, when removing the blade unit from the container, when removing the grinding blade from the chamber and during cleaning.
- Do not attempt to grind bones, nut shells or other hard ingredients.
- Hot liquids with a temperature of up to 55 °C can be processed in the stainless steel container. Take extra care when handling hot liquids and food. Hot steam or splashing hot liquids and food may cause scalding. Never turn on the blender without the lid properly attached. If you are processing hot liquids, do not remove the inner lid during operation. Do not touch the hot surface. For carrying the heated blender container use the handle.
- The maximum continuous operating time is 10 minutes. In kneading mode, do not exceed the maximum operating time of 5 minutes and when using the blender, do not exceed the operating time of 2 minutes. Allow the appliance to cool down for 30 minutes before starting again.

Safety During Maintenance

- Always allow the appliance to cool completely before cleaning.
- Regularly clean the appliance after each use according to the instructions in the Maintenance and Cleaning chapter. Do not perform any maintenance on the appliance other than the cleaning described in the Maintenance and Cleaning chapter.
- Do not wash the multifunction head or stand under running water or immerse it in water or any other liquid. The stand mixer is not dishwasher safe.
- The removable attachments are intended for short term contact with food (including beverages), i.e. max. 4 hours. Do not leave them submerged, for example in water, for a long time to avoid damaging their finish.
- Before storing the appliance, make sure that the multifunction head is tilted to a horizontal position.

EXPLANATION OF SYMBOLS PLACED ON THE PRODUCT OR IN THE ACCOMPANYING DOCUMENTATION



The product meets all the basic requirements of the applicable EU directives.



This symbol on products or accompanying documents means that used electric or electronic products must not be added to ordinary municipal waste.



This symbol on the accumulator or battery means that the used battery must not be added to normal municipal waste.

- Thank you for purchasing our SENCOR product; we hope it will serve to your satisfaction.
- Prior to using this appliance, please read the user manual thoroughly, even in cases when you are already familiar with the use of similar types of appliances. Use the appliance only as described in this user manual. Keep the manual for future reference. If you pass the appliance on to another person, ensure that this user manual is included.
- Carefully unpack the appliance and make sure not to discard any part of the packaging material until you have removed all its components. It is recommended that you keep the original packaging, packing material, receipt and confirmation of the extent of the seller's liability or warranty certificate at least for the duration of the legal right to file a defect claim or the quality warranty. When transporting the appliance, we recommend repackaging it in the original box provided by the manufacturer.

- D13** Separator
D14 Kebbe meat ball maker attachment

- D15** Cookie maker
D16 Cookie maker holder

DESCRIPTION OF THE GRATER (Fig. E)

- E1** Pusher
E2 Grater
E3 Attachment for mashing potato
E4 Attachment for coarse grating
E5 Attachment for cutting thin slices
E6 Attachment for fine grating

DESCRIPTION OF THE SCALE (Fig. F)

- F1** Weighing area
F2 UNIT button
F3 Display
F4 $\frac{0}{TARA}$ button
F5 Battery compartment cover
F6 Battery compartment (3x 1.5 V AAA batteries)

DESCRIPTION OF THE APPLIANCE (Fig. A)

- | | |
|--|--|
| A1 Tilttable multifunction head | A8 Rotary knob |
| A2 Removable cover of the front outlet for attaching the meat grinder or grating and cutting attachment | A9 Safety catch for tilting and folding the multifunction head |
| A3 Clamping shaft | A10 Lighting of the bowl interior |
| A4 Stainless steel container compartment | A11 Power cord |
| A5 Base | A12 Button for releasing the meat grinder or grating and cutting attachment |
| A6 Non-slip feet for the stability of the appliance during operation | A13 Front outlet for the meat grinder or grating and cutting attachment |
| A7 Removable cover of the upper outlet for attaching the blender | A14 Upper outlet for the blender |
| | A15 Storage space for the scale |

DESCRIPTION OF ACCESSORIES (Fig. B)

- | | |
|--|---|
| B1 Large stainless steel stand mixer container with a volume of 5.5 l | B5 Kneading hook |
| B2 Small stainless steel stand mixer container with a volume of 4 l | B6 Flexible beater |
| B3 Balloon whisk | B7 Lid for the stainless steel container |
| B4 Beater | B8 Transparent bowl cover with filling opening |
| | B9 Scale |

DESCRIPTION OF THE BLENDER CONTAINER (Fig. C), only STM 7651WS

- | | |
|---|---|
| C1 Inner lid | C4 Blades unit |
| C2 Perimeter lid with an opening for adding ingredients (after removing the inner lid) | C5 Handle of the blender container |
| C3 Blender container with a volume of 1.5 l | C6 Base for attaching/removing the blender from the outlet |

DESCRIPTION OF THE MEAT GRINDER WITH ACCESSORIES (Fig. D)

- | | |
|--|---------------------------------------|
| D1 Meat grinder | D7 Screw cap |
| D2 Screw shaft | D8 Pusher |
| D3 Grinding blade | D9 Aluminium hopper |
| D4 Fine grinding plate | D10 Grinding chamber |
| D5 Medium coarse grinding plate | D11 Sausage filling attachment |
| D6 Coarse grinding plate | D12 Conical end cap |

THE PURPOSE OF USING THE APPLIANCE

- The stand mixer is designed to process a standard amount of food in the household. It is suitable for blending, whipping, kneading, grinding, making cookies, filling sausages or grating.
- The package also includes a kitchen scale with a weighing capacity of up to 5 kg.

QUICK GUIDE AND BASIC CONTROLS (Fig. G)

- Your stand mixer is supplied with rich accessories for various purposes of use. Always use only one accessory. Accessories cannot be combined and used simultaneously.

Stand Mixer (Fig. G1)

- The stand mixer is suitable for whipping egg whites or cream; mixing cake or muffin dough; or kneading dough for bread or pizza.
- Attach one of the attachments (balloon whisk, beater, kneading hook, flexible beater).
- Select the speed and process the ingredients.
- For more information, see the **MIXING, WHIPPING, KNEADING** section later in the manual.

Blender (Fig. G2), only STM 7651WS

- The blender is suitable for quick and effective blending, crushing, mixing and emulsifying various ingredients and preparing dishes and drinks, such as smoothies, soups, sauces, spreads, dressings or iced drinks. Thanks to powerful blades and high speed, the blender can easily handle fruit, vegetables and ice.
- Assemble the stand mixer with the blender.
- Select the speed and process the ingredients.
- For more information, see the **BLENDING** section later in the manual.

Meat Grinder, for Filling Sausages, for Making Meat Balls and Cookies (Fig. G3)

- Assemble the stand mixer:
 - with a meat grinder for grinding meat for patties, burgers, meatloaf or pâté;
 - with a sausage filling attachment for making sausages or frankfurters;
 - with a kebbe meat ball maker attachment for making balls and their subsequent filling;
 - with a cookie maker for making machine cookies or machine biscuits.
- Select the speed and process the ingredients.

- For more information, see the **GRINDING MEAT, FILLING SAUSAGES, MAKING MEAT BALLS AND COOKIES** section later in the manual.

Grater (Fig. G4)

- Select one of the grater attachments, insert it into the grater chamber.
- Assemble the stand mixer with the grater.
- Select the speed and process the ingredients.
- For more information, see the **GRATING** section later in the manual.

Kitchen Scale

- The stand mixer is equipped with a removable kitchen scale.
- Turn on the scale with the  button and weigh the ingredients that you will process in the stand mixer.
- For more information, see the **KITCHEN SCALE** section later in the manual.

Rotary Knob (Fig. G5)

- The rotary knob is used for continuous adjustment of the speed level, pulse level (P) and switching off the appliance (O).
- Positions on the controller:
 - P: pulse level (available only for the blender);
 - O: The appliance is switched off;
 - 1–6: speed levels, where 1 is the lowest speed and 6 is the highest speed.

Overview of Recommended Speeds According to the Method of Use

Accessories	Speed	Quantity	Cooking time	Note
Kneading hook	1–3	200–1000 g	5 minutes	Dense dough for bread or pizza
Beater, flexible beater	2–4	200–1000 g	5 minutes	Cake dough, sponge cake, etc.
Balloon whisk	5–6	200–800 ml	6 minutes	Egg whites, whipping cream or light doughs e.g. for pancakes
Meat grinder	4–5	200–1000 g	6 minutes	Grinding meat, filling sausages, preparing meat balls and cookies
Grater	4–5	200–1000 g	6 minutes	Grating vegetables and fruit, cheese, etc.
Blender	6	200–1000 g	2 minutes	Blending of food

BEFORE FIRST USE

- Remove the stand mixer and all accessories from the packaging material. Remove any promotional labels or tags. Check that neither the stand mixer nor the accessories are damaged.
- Before storing or disposing of the packaging material, check that you have removed all parts and accessories from the packaging compartments and packaging material.
- Wipe the body of the stand mixer and the scale with a slightly moistened soft cloth. Wipe with a dry cloth.
- Thoroughly wash the accessories and parts that come into contact with food (see the list below) with warm water using a neutral kitchen detergent. Then rinse everything with clean water and allow to dry freely, or wipe dry with a soft cloth.
- Accessories and parts suitable for hand washing:

- Both stainless steel stand mixer containers
- Balloon whisk
- Beater
- Kneading hook
- Flexible beater
- Transparent bowl cover with filling opening
- Lid for the stainless steel container
- Blender container with lid and inner lid
- Meat grinder with its accessories (all parts of Figure D)
- Grater and its attachments (all parts of Figure E)



Caution:

No part of the stand mixer or accessories are dishwasher safe.



Caution:

When handling the blade unit of the blender container, the grinding blade or grater attachments, take extra care to avoid injury.



Caution:

Do not rinse the body of the stand mixer, power cord or plug under water or immerse them in water.



Note:

You may notice a slight odour on first use. This is a normal occurrence which disappears with use.

MIXING, WHIPPING, KNEADING

Planetary Mixing System

- The stand mixer is equipped with a planetary mixing system, which ensures thorough and even processing of the ingredients. The attachment rotates both around its own axis and around the perimeter of the bowl. Thanks to this double rotation, the entire interior of the container is covered and the ingredients are better mixed without the need to scrape the walls.

Assembly (Fig. H1–H5)



Caution:

Make sure the stand mixer is switched off and unplugged from the mains socket before assembling or disassembling the accessories. If you attach an attachment when the multifunction head is plugged in, it may be accidentally switched on resulting in serious injury.

Attaching the Attachment

- Place the stand mixer on a flat, dry and stable surface, such as the worktop of a kitchen unit.
- Hold the multifunction head with one hand and press the safety catch with the other hand. This releases the head. Tilt the head up until it stops, so that a click is heard.
- Remove the bowl by turning it anticlockwise.
- Select an attachment – see the table below, and slide it onto the clamping shaft. Turning the attachment clockwise will secure it. Gently pull the attachment down with one hand to verify that it is properly attached.

Selecting the Type of Attachment

Attachment type	Usage
Balloon whisk	It is used for whipping whole eggs or egg whites, whipped cream, mousse creams, etc. Do not use it to mix or knead dough.
Beater	It is used for mixing light to medium-heavy doughs without yeast, for preparing glazes, creams, cake mixes, fillings, etc. Do not use it for kneading heavy doughs.
Kneading hook	It is used for kneading various types of dough, including heavy and dense doughs, such as bread dough, pizza dough, fresh pasta dough, etc.
Flexible beater	It is used for mixing dessert creams, instant puddings, mayonnaise, sponge cake dough, etc. Do not use it for kneading heavy doughs.

Inserting Ingredients Into the Bowl

- Place the ingredients you want to process in the stainless steel bowl.
- We recommend filling the bowl to a maximum of 2/3 of the total volume. If you put too small an amount of ingredients into the bowl (less than 0.3 l of dough), they may not be optimally processed.

Securing the Bowl

- Insert the stainless steel bowl into the opening in the base and secure it by turning it clockwise (towards the locked lock symbol). If the bowl is properly secured, it cannot be lifted separately from the base.
- With one hand press the safety catch and with the other hand press the multifunction head down until a click is heard.

Using the Transparent Bowl Cover

- If you decide to use the transparent cover, first put the larger circular cover on the bowl so that it fits properly around the entire perimeter of the bowl. Then snap the top cover onto the circular cover.

Usage

- Connect the power cord to a properly earthed mains socket.
- Use the rotary knob to set the desired speed level in the range of 1 to 6. We recommend starting at a lower speed and gradually increasing it. You can change the speed setting during operation.
- We recommend processing ingredients first at a lower speed level; this will prevent splattering of ingredients. As soon as they are mixed together, increase the speed to the required level.



Caution:

During operation, objects such as spoons, kitchen knives, forks, etc. must not be inserted into the container as this could cause injury or damage to the appliance.

Releasing Stuck Ingredients

- If an ingredient (e.g. dough) sticks to the edges of the container, turn the stand mixer off by setting the control to position 0 (off) and disconnect from the mains socket.
- If you have used a bowl cover, remove it first. Then tilt the multifunction head.
- Use a regular spatula to remove the stuck ingredient from the edge of the container and put it in the middle of the container.
- Fold the head back to the working position and put the transparent cover on the bowl. Continue with the preparation.

Operating Time of the Stand Mixer

- When mixing, whipping or kneading, do not leave the appliance in continuous operation for more than 10 minutes.
- When kneading heavy and dense dough, do not leave the appliance in operation for more than 5 minutes.
- After any of these times have elapsed, turn off the appliance and allow it to cool down. The appliance can be used again after 30 minutes.

Quick Guide to Processing Ingredients

Attachment type	Additives	Maximum amount	Processing time	Speed selection
Balloon whisk	Egg whites	12 pcs	4 min	5–6
	Whisking cream	1 l	6–8 min	5–6
Beater or flexible beater	Cake dough	1 kg	6 min	3–4
Kneading hook	Bread dough, pizza dough	1 kg	4–5 min	1–2



Note:

The above processing times are only a reference. To prevent ingredients from splattering out of the bowl, select an initial speed level of 1 or 2. Later set a higher speed based on requirements. For easier mixing of dough we recommend soft margarine or butter. When whipping egg whites, the container and whisk must be completely clean and dry. Even a small amount of fat can cause the egg whites not to be whipped to the desired snow consistency. Whipping cream should be cooled to a temperature of 6 °C before whipping. Allow the ingredients for preparing various types of dough to rest at room temperature before processing.

End of operation and dismantling of accessories (Fig. H6–H8)

- After you have finished using it, set the rotary knob to position 0 (off) and disconnect the power cord from the mains socket.
- If you have been using the transparent bowl cover, remove it. Unclip the top cover from the larger circular cover and then remove the circular cover from the bowl.
- Grasp the multifunction head with one hand and press the safety catch with the other hand. This releases the head. Tilt the head up until it stops, so that a click is heard.
- Turn the attachment anticlockwise to release it and remove it.
- Turn the stainless steel bowl anticlockwise (towards the unlocked lock symbol) and remove it from the base.
- Return the multifunction head to the horizontal position.
- After each use, clean the stand mixer and used accessories according to the instructions in the **CLEANING AND MAINTENANCE** chapter.

BLENDING, only STM 7651WS



Caution:

Make sure the stand mixer is switched off and unplugged from the mains socket before assembling or disassembling the accessories. If you attach an attachment when the multifunction head is plugged in, it may be accidentally switched on resulting in serious injury. The multifunction head must be folded down to the horizontal position and the whisk, beater or kneading attachment must be dismantled.

Assembling the Blender (Fig. I1–I2)

- Place the stand mixer on a flat, dry and stable surface, such as the worktop of a kitchen unit.
- Remove the upper outlet cover.
- Place the blender container on the upper outlet and twist it to secure it in the working position. The safety lock will not allow the blender to start if it is not properly attached to the multifunction head.
- Remove the perimeter lid from the blender container.
- Put the ingredients into the blender container. We recommend cutting larger foods into smaller pieces beforehand.

**Note:**

The maximum capacity of the blender container is 1.5 l. Never fill it above the maximum mark. When processing hot liquids or liquids that increase in volume during blending, we recommend filling the container to a maximum of 2/3 of its maximum capacity.

- Put the perimeter lid on the container so that its edges follow the neck of the container, and press it down properly around the entire perimeter.
- Make sure that the inner lid is properly attached.

Blending (Fig. I3–I6)

- Make sure that the stand mixer is correctly assembled and that the rotary knob is set to position O (off). Connect the power cord to a properly earthed mains socket.
- Use the rotary knob to set the desired speed level. We first recommend setting a lower speed so that the ingredients are mixed. You can then increase the speed.
- If you want to blend food only very briefly at maximum speed, turn the control to position P and hold it briefly in this position. As soon as you release the control, it automatically returns to position O (off).

**Caution:**

Hot liquids with a temperature of up to 55 °C can be processed in the blender container. The maximum operating time of the blender is 2 minutes. Do not leave the appliance in continuous operation for longer than indicated above. Then let it cool down for 30 minutes.

- You can add food or liquids to the container during blending through the opening in the lid after removing the inner lid. Remove the inner lid by turning it anticlockwise and then removing it.
- Never remove the perimeter lid during operation. When processing hot liquids, the inner lid must remain closed.
- If food is sticking to the blade unit or the walls of the container, turn off the appliance by turning the control to position O (off) and disconnect it from the power socket. Make sure that the blade unit has stopped rotating. Carefully dismantle the assembled container from the multifunction head by turning it and pulling it upwards. Lift the lid and use a spatula to clean the blade unit and the walls of the container. Close the lid and attach the blender assembly back to the multifunction head. Connect the power cord to the socket and continue blending.

Quick Guide to Processing Ingredients

Ingredients	Speed selection	Recommended blending time
Fruit, vegetables cut into smaller pieces	5–6	30 s
Baby food, side dishes	5–6	40 s
Spreads, dressings, marinades	3–4	30 s
Smoothies and cocktails	5–6	40 s
Soups	5–6	30 s
Ice cubes	Pulse mode (P)	

**Note:**

The above food processing times are indicative only. The actual blending time depends on the size of the food, its quantity and the required final consistency.

End of Operation and Dismantling of the Blender

- After you have finished using it, set the rotary knob to position O (off) and disconnect the power cord from the mains socket.
- Make sure that the blade unit has stopped rotating and carefully remove the blender container assembly from the multifunction head. Put the cover back in place and use a soft plastic spatula to remove food from the blender container.

- After each use, clean the blender container and used accessories according to the instructions in the **CLEANING AND MAINTENANCE** chapter.

**Tip:**

For easy release of the perimeter lid, grasp the handle with one hand and lift your thumb up so that it touches the perimeter lid from underneath. Gently push your thumb up and the lid will release from the neck of the blender container.

Tips and Advice for Blending

- Foods with a solid consistency, such as fruit or vegetables, should first be cut into smaller pieces about 3 cm in size before blending them.
- First blend a smaller amount of ingredients and gradually add more ingredients through the opening in the lid during blending. This will achieve better results than if you put all the ingredients into the blender container at once.
- If you need to process solid consistency foods at the same time as liquids, we recommend first blending the solid consistency foods and some of the liquids. Then gradually add the rest of the liquids through the opening in the lid during blending.
- For blending very thick liquids, we recommend using the pulse level to prevent frequent jamming of the blade unit. Operate the blender repeatedly at short intervals.
- Ice cubes need to be processed immediately after removal from the freezer. Once the ice starts to melt, the cubes will join together and it will not be possible to blend them.

GRINDING MEAT, FILLING SAUSAGES, MAKING MEAT BALLS AND COOKIES**Caution:**

Make sure the stand mixer is switched off and unplugged from the mains socket before assembling or disassembling the accessories. If you attach an attachment when the multifunction head is plugged in, it may be accidentally switched on resulting in serious injury.

The multifunction head must be folded down to the horizontal position and the whisk, beater or kneading attachment must be dismantled.

Assembling the Meat Grinder (Fig. J1)

- Place the stand mixer on a flat, dry and stable surface, such as the worktop of a kitchen unit.
- Insert the screw shaft into the grinding chamber with the gear wheel first.
- Fit the grinding blade onto the shaft (with the edge facing out of the grinding chamber) and fit the grinding plate onto it (depending on the preferred grinding coarseness). Make sure that the protrusions in the grinding plate fit into the recesses in the grinding chamber.

**Caution:**

When attaching the grinding blade, be very careful not to get injured with its edge.

- Fit the screw cap onto the grinding chamber and secure it properly by screwing it clockwise.

Assembling the meat grinder for filling sausages (Fig. J2)

- Place the stand mixer on a flat, dry and stable surface, such as the worktop of a kitchen unit.
- Insert the screw shaft into the grinding chamber with the gear wheel first.
- Fit the separator onto the shaft and the sausage filling attachment onto it.
- Fit the screw cap onto the grinding chamber and secure it properly by screwing it clockwise. When tightening the screw cap, we recommend holding the sausage filling attachment with one hand to keep the attachment centred.

Assembling the meat grinder for making kebbe meat balls (Fig. J3)

1. Place the stand mixer on a flat, dry and stable surface, such as the worktop of a kitchen unit.
2. Insert the screw shaft into the grinding chamber with the gear wheel first.
3. Fit the kebbe meat ball maker attachment onto the shaft and fit the conical end cap onto it.
4. Fit the screw cap onto the grinding chamber and secure it properly by screwing it clockwise.

Assembling the Meat Grinder for Making Cookies (Fig. J4)

1. Place the stand mixer on a flat, dry and stable surface, such as the worktop of a kitchen unit.
2. Remove the cookie maker from the holder.
3. Insert the screw shaft into the grinding chamber with the gear wheel first.
4. Fit the cookie maker holder onto the shaft.
5. Fit the screw cap onto the grinding chamber and secure it properly by screwing it clockwise. When tightening the screw cap, we recommend holding the cookie maker holder with one hand so that it is in a horizontal position after tightening.
6. Insert the cookie maker into the opening in the holder.

Mounting the Assembled Grinder Onto the Stand Mixer (Fig. J5–J7)

- Make sure that the stand mixer is disconnected from the mains socket. The multifunction head must be folded down to the horizontal position and the whisk, beater or kneading attachment must be dismantled.
- Remove the front cover from the multifunction head. Tilt the assembled grinder to the right at an angle of approximately 45°, insert it into the front outlet and secure it in the operating position by turning it anticlockwise. The operating position is indicated by the button being extended and an audible click.



Note:

The stand mixer is equipped with a safety lock that prevents it from starting if the grinder is not correctly attached and secured to the front outlet.

- Fit the stainless steel hopper onto the upper filling opening of the grinder.

Grinding Meat

- First prepare the meat for grinding as follows: Bone it, remove tendons, cartilage and cut it into pieces of approx. 2 × 2 × 6 cm, which will freely pass through the upper filling opening of the grinder.



Caution:

Do not process frozen meat. Let it thaw before grinding.

- Place a suitable container under the grinder outlet to catch the processed food.
- Connect the power cord to a properly earthed mains socket.
- Use the rotary knob to set the desired speed level. We first recommend setting speed 3 and then increasing it as needed.
- Gradually put pieces of meat into the filling opening and press them with the pusher.
- Make sure that the filling opening is not clogged with a large amount of meat. Do not process more than 5 kg of meat in one batch.
- The processing time is in the order of several minutes.



Caution:

Do not use your fingers or other objects to press the meat. Always use the pusher **D8** intended for this purpose.

- The minced meat will fall into the prepared container. Meat residues that remain in the grinding chamber **D10** can be removed by grinding a slice of bread or a roll.

Blocking the Grinder When Grinding Meat

- If the meat becomes blocked during operation, the grinder will stop.
- Turn off the stand mixer by turning the control to position **O** (off) and disconnect the power cord from the mains socket.
- Remove the grinder assembly and disassemble it in the reverse order that you assembled it, and remove the ingredients that caused the blockage.
- Wash the grinder and its parts as needed and reassemble. Reattach to the stand mixer and continue processing.



Caution:

Do not use higher speed or pulse speed to unblock the meat. Always turn off the stand mixer and disconnect it from the power source. Disassemble it to remove the cause of the blockage.



Caution:

If the grinder becomes blocked, turn off the stand mixer immediately. Do not leave it in operation for a long time. There is a risk of motor overheating and damage.

Filling Sausages

- Prepare the casing that you will be filling with minced meat and let it soak in lukewarm water for about 10 minutes.
- Place the ground meat mixture on the hopper.
- Remove the casing from the water and skewer or tie one end and slide the other end like an accordion onto the sausage filling attachment.
- Use the rotary knob to set the desired speed level. We recommend setting a lower speed level first and then increasing it as needed.
- Hold the casing on the attachment with one hand and use the other hand to push the ground meat mixture through the filling opening of the grinder using the pusher.
- If the casing sticks to the attachment, it needs to be moistened with water again.
- When the casing is filled over its entire length, or you have used up the meat mixture, remove the end of the casing from the attachment and close it with a skewer or a knot.
- Start shaping the sausages by twisting. Twist the ends in opposite directions (one to the right, the other to the left) at the desired length to prevent them from unravelling. Repeat this process over the entire length of the casing to shape the sausages.



Tip:

You can also use food string to shape the sausages by closing the ends of the sausages with a simple knot.



Caution:

Do not use your fingers or other objects to press the meat. Always use the pusher intended for this purpose.



Note:

Do not press on the casing to avoid tearing it. If this happens, close both torn ends and continue filling.

Making Kebbe Meat Balls

- Place the prepared meat mixture on the hopper.
- Use the rotary knob to set the desired speed level. We recommend setting a lower speed level first and then increasing it as needed.
- Push the mixture through the filling opening using the pusher.
- Place a board under the attachment outlet or insert your free hand. The result will be a hollow meat tube, which is cut into smaller pieces and filled with a meat mixture. It is then fried in oil or baked in the oven.



Caution:

Do not use your fingers or other objects to press the meat. Always use the pusher intended for this purpose.

Making Cookies

- Place the prepared dough on the hopper.
- Set the desired cookie shape by moving the cookie maker in the holder to the left or right.
- Use the rotary knob to set the desired speed level. When first starting, we recommend setting speed 3 and then decreasing or increasing it as needed.
- Push the dough through the filling opening using the pusher **D8**. The result will be dough in the desired shape that you set using the cookie maker.



Caution:

Do not use your fingers or other objects to press the dough. Always use the pusher intended for this purpose.

- It is recommended to hold a tray or palm under the extruded dough. Then cut the shaped dough into smaller pieces.

End of Operation and Dismantling of the Grinder (Fig. J8–J9)

- After you have finished using it, set the rotary knob to position **O** (off) and disconnect the power cord from the mains socket.
- When dismantling the grinder, first remove the hopper. Then press the button and remove the grinder by turning it clockwise. After removing the grinder, put the cover back in place.
- When disassembling the grinder into individual components, proceed in the reverse order to its assembly.
- After each use, clean the grinder and used accessories according to the instructions in the **CLEANING AND MAINTENANCE** chapter.

GRATING



Caution:

Make sure the stand mixer is switched off and unplugged from the mains socket before assembling or disassembling the accessories. If you attach an attachment when the multifunction head is plugged in, it may be accidentally switched on resulting in serious injury. The multifunction head must be folded down to the horizontal position and the whisk, beater or kneading attachment must be dismantled.

Assembling the grater (Fig. K1)

1. Place the stand mixer on a flat, dry and stable surface, such as the worktop of a kitchen unit.
2. Insert one of the attachments into the grater chamber. The protrusion at the end of the chamber must fit into the recess at the narrower end of the attachment.



Caution:

When inserting the attachment into the grater, be very careful not to get injured by its edge.

Mounting the Grater Onto the Stand Mixer (Fig. K2–K4)

- Make sure that the stand mixer is disconnected from the mains socket. The multifunction head must be folded down to the horizontal position and the whisk, beater or kneading attachment must be dismantled.
- Remove the front cover from the multifunction head. Tilt the assembled grater to the right at an angle of approximately 45°, insert it into the front outlet and set it to the operating position by turning it anticlockwise. The operating position is indicated by the button being extended and an audible click.



Note:

The stand mixer is equipped with a safety lock that prevents it from starting if the grater is not correctly attached and secured to the front outlet.

Using the Grater

- The grater is designed for processing almost all types of fruit, vegetables and other foods commonly used in the household.
- Prepare the food and cut it into pieces that will pass through the upper filling opening of the grater. Some types of fruit and vegetables will need to have seeds or stones removed.
- Place a suitable container under the grater to catch the processed food.
- Connect the power cord to a properly earthed mains socket. Use the rotary knob to set the desired speed level.
- Start gradually inserting ingredients into the filling opening. Use the supplied pusher to push the ingredients through the filling opening.



Caution:

Do not use your fingers or other objects to press the food. Always use the pusher intended for this purpose.

- Always put individual pieces of the ingredient into the filling opening and press on the pusher with moderate force and smoothly. During operation, check the condition and flow of the attachment by looking into the filling opening. Never fill the filling opening with the ingredient up to its upper edge. Processing a large amount of ingredients at once can cause overloading of the stand mixer's multifunction head.

End of Operation and Dismantling of the Grater (Fig. K5–K6)

- After you have finished using it, set the rotary knob to position **O** (off) and disconnect the power cord from the mains socket.
- When dismantling the grater, first remove the pusher. Then press the button and remove the grater by turning it clockwise. After removing the grater, put the cover back in place.
- When disassembling the grater into individual components, proceed in the reverse order to its assembly.
- After each use, clean the grater and used accessories according to the instructions in the **CLEANING AND MAINTENANCE** chapter.

Useful Advice for Grating

- For best results, process fresh, not overripe fruit. The same applies to vegetables.
- Softer fruits, such as strawberries, can be placed in the freezer for a few minutes before processing.
- Semi-hard cheese will be better processed if you store it in the refrigerator overnight or in the freezer for 30 minutes.
- We do not recommend processing soft or already grated cheese, as it may clog the filling opening.
- If you are using a fine grater or a thin slicing attachment, push the food through the filling opening lightly. When using a coarse grater or an attachment for cutting thicker slices, it is necessary to push the food with greater force.



KITCHEN SCALE

- The kitchen scale is located in the base column. Grasp it from below to remove it from the storage space – see Figure **L**.

Inserting/Replacing Batteries

- The scale is powered by alkaline batteries (3× 1.5 V AAA).
- If batteries are inserted into the battery compartment at the bottom of the scale, pull out the insulating tape that protects the batteries from discharge and damage to the scale so that you can use the scale.
- If the batteries are not inserted, press the battery compartment cover latch and remove the cover. Insert the batteries into the compartment. Observe the correct polarity, which is shown on the bottom of the battery compartment, and fit the cover. Press until you hear a click. This indicates that the lid is properly closed.
- As soon as "**Lo**" appears on the display, replace the batteries with new ones. Remove the battery compartment cover and remove the flat batteries. Insert new batteries of the same type. Observe the correct polarity, which is shown on the bottom of the battery compartment, and fit the cover.

Turning the Scale On and Off

- Press the  button to turn the scale on. Wait until “0” is shown on the display.
- Long press the  button to switch off the scale.
- The scale will automatically turn off after approximately 1 minute of inactivity.

Weighing Food (Ingredients)

- Place the scale on a flat and stable surface and turn it on. Wait until “0” is shown on the display.
- Place the ingredients to be weighed in the centre of the area. The display will show its weight.





Note:

We recommend not to put the ingredients directly on the scale, but to use a food foil, a bowl or another container. If you are going to weigh food in a bowl, press the  button to zero the value on the scale.

TARA Function

- The TARA function is used when you want to gradually weigh several ingredients in one container without removing the container from the scale. This function will automatically subtract the weight of the container from the total weight of the ingredients.

1. Place the empty container on the scale. The display will show its weight. Pressing the  button will zero the value and the **T** symbol will light up in the bottom left corner.
2. Put the first food into the container. The display will show its weight. Pressing the  button will zero the value and the **T** symbol will remain lit. The weight of the first food is stored in the memory and the scale is ready for further weighing.
3. Add more food in the same way up to the maximum load capacity of the scale.
4. Once you remove the food container from the scale, the total negative value will be displayed.

Choice of Weight Units

- When the scale is on, repeatedly pressing the **UNIT** button will toggle between weight units: g or lb.oz.

Error Messages

Display	What to do
Lo	Batteries are flat. Replace the batteries. Follow the instructions in the Inserting/replacing batteries section.
Err	You have exceeded the maximum load capacity of the scale.

LINKING THE SCALE AND THE SMART DEVICE

- The scale is equipped with Bluetooth wireless technology, which in conjunction with the free **Sencor FOOD** app installed on your smart device offers direct access to a rich and regularly updated database of foods and their nutritional values.
- The **Sencor FOOD** app was developed in collaboration with the creators of the Calorie Tables / Dine4Fit app and is designed for smartphones running iOS (version 13 and above) or Android (version 5 and above). When using the app, the phone must be connected to the internet.

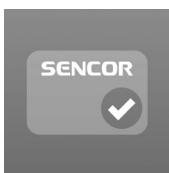

- The connection of the scale to the phone takes place automatically after starting the application. To pair, it is sufficient for the Bluetooth function to be turned on on the smart device. If the app does not find the scale, it will actively prompt you to try to reconnect the scale.
- When the scale is paired with the application, the Bluetooth icon is lit on the display. When the scale is not paired with the app or the connection has been broken, the Bluetooth icon will be extinguished.



Note:

The scale can only connect to one mobile device at a time. If you have problems with pairing, make sure that there is no other device within reach that is actually actively connected to the scale.

The app offers two weighing modes:

1. “On the Scale” Mode

Displays the weight of the currently weighed item. After you tell the scale what food you weigh using the “Search Food” field, it will display the nutritional values of the food in relation to the current weight.

2. “Recipes” mode

In this section you will find recipes that we have prepared for you. The recipes are compiled using SENCOR stand mixers. The recipe will guide you through the preparation and help you to record the actually weighted weights of the individual ingredients in the List tab.

3. “List” Mode

It allows you to determine the aggregate nutritional value of more food. This mode is useful, for example, when preparing a dish according to a recipe. Gradually add the food to the scale, using the “Search Food” field to enter what food it is. Once you have determined the weight and type of food, use the “+ Add food to list” button to add it to the total nutritional sum. Use the /TARA button on the scale for adding to weight as needed during weighing. The scale continuously shows the total weight of the ingredients and calculates the weights of the individual nutritional components (for example, how many grams of carbohydrates the weighed food contains in total) throughout the weighing in the “List” mode.

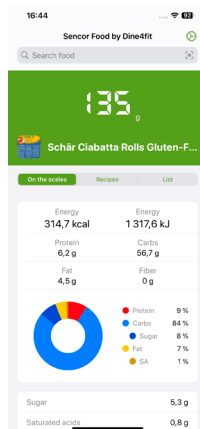

Entering/Searching for a Weighed Food

- You can find a summary of the nutritional values of a weighed food by entering the name of the food in the "Search Food" status bar. Click on the status bar and the cursor and keyboard will appear. Enter the name of the food or a keyword, the application will search for the relevant food or a list of foods with a keyword, and selecting a food will display its nutritional values.
- You can find the nutritional summary more quickly, practically and accurately by scanning a unique EAN barcode that will appear. Enter the packaging. Click on the barcode icon to the right of the "Search Food" status bar and scan the barcode. A summary of nutritional values is displayed.



Note:

If you didn't allow the app to use the camera and video recording feature when you installed the app (or when adjusting the settings), enable the feature. Otherwise it will not be possible to scan the barcodes.



Note:

The **Sencor FOOD** app is linked to the Calorie Tables app. At the end of the weighing, you can enter your food into your diet in the Calorie Tables with one click and keep a long-term overview of your food intake (ATTENTION: Some advanced features of the Calorie Tables app may be subject to a fee).

Possible Problems with the App and Their Solutions

- The app does not search for the weighted food item.
 - Please check your current internet connection.
- Bluetooth connection failed.
 - Check that only one device is connected to the scale.
 - Check that the Bluetooth version on your device is 4.0 and later.
- The data from the scale cannot be displayed in the application.
 - Check that you have enabled the Bluetooth feature on your phone/tablet.
 - Check that you are within the range of the Bluetooth signal.
 - Check that the batteries in the scale are not dead. Replace the batteries with new ones.
 - Restart the app.
 - Reset the operating system and the Bluetooth connection.
- If you are near other devices transmitting in the same frequency band as Bluetooth (Wi-Fi router, DAB radio, microwave oven, other smart phone, etc.), interference may occur. Try moving the scale or smart device to a different location.

STORAGE

- If you will not be using the kitchen scale, insert it into the storage space in the base column. The kitchen scale easily adheres to the wall using a magnet.
- If you will not be using the kitchen scale for an extended period, remove the batteries from it to prevent damage in case of electrolyte leakage.

CLEANING AND MAINTENANCE

- Before cleaning, turn off the stand mixer by switching the rotary knob to position 0 (off) and disconnect the power cord plug from the mains socket. Allow the appliance to cool down.
- Clean the stand mixer and the used attachment immediately after use. Do not allow food residues to dry out.



Caution:

To prevent the risk of electric shock, do not immerse the appliance, power cable, or plug into water or any other liquid.



Caution:

Do not use abrasive cleaning agents, solvents, etc. to clean any parts of the appliance, as these could damage the surface. None of the components of this appliance are dishwasher safe.



Caution:

Do not use scouring pads (metal or plastic) to clean any parts of the appliance. They can scratch the surface and damage its finish.

Stand Mixer and Scale

- Wipe the body of the stand mixer and the scale with a slightly moistened soft cloth. Wipe with a dry cloth.

Attachments and Accessory Parts

- Thoroughly wash the accessories and parts that come into contact with food (see the list below) with warm water using a neutral kitchen detergent. Then rinse everything with clean water and allow to dry freely, or wipe dry with a soft cloth.
- Accessories and parts suitable for hand washing:
 - Both stainless steel stand mixer containers
 - Balloon whisk
 - Beater
 - Kneading hook
 - Flexible beater
 - Transparent bowl cover with filling opening
 - Lid for the stainless steel container
 - Blender container with lid and inner lid
 - Meat grinder with its accessories (all parts of Figure D)
 - Grater and its attachments (all parts of Figure E)



Caution:

No part of the stand mixer or accessories are dishwasher safe.



Caution:

When handling the blade unit of the blender container, the grinding blade or grater attachments, take extra care to avoid injury.

Tips and Advice for Cleaning and Maintaining Attachments and Accessories

- You can also use a brush with soft bristles to clean and remove food residues.
- If you have whipped egg whites, first rinse the stainless steel bowl and the used whisk with cold water. If you were to use hot water, the egg white remains would harden and their removal would be more difficult.
- You can easily clean the blender container by filling it with 0.5 l of clean water with the addition of a few drops of kitchen dish washing detergent, and then assembling the blender and operating it for 10 to 15 seconds. Then turn off the stand mixer, disconnect it from the mains socket and after the rotating parts stop, dismantle the blender container assembly from it. Empty the contents of the blender container and then rinse the container thoroughly with clean water and wipe it dry. Use a brush with a long handle to remove any food residue under the blades of the blade unit.
- Remove meat and meat mixture residue in the openings of the grinding plates using a toothpick or fine brush.
- After cleaning, wipe the grinding plates and grinding blade with a small amount of vegetable oil that you have applied to a paper kitchen towel. This will extend their lifetime and prevent possible corrosion.
- Rinse the sausage filling attachment with a stream of warm water. You can use a narrow round brush to remove meat mixture residue inside the attachment. Wipe dry or allow to dry thoroughly.
- Remove dough residue from the openings in the cookie maker using a soft brush and a stream of warm water.

STORAGE

- Before storage, the appliance and its accessories must be completely cool, switched off and disconnected from the power supply, clean and dry.
- Insert the stainless steel bowl into the base of the stand and you can store the attachments in it. Fold the multifunction head down to the horizontal position. Store the stand mixer and all accessories in a clean, dry place out of the reach of children.
- The meat grinder pusher is used to store the meat grinder accessories. Remove the top cover of the pusher and insert the accessories in this order: conical end cap, sausage filling attachment, kebabe meat ball maker attachment, separator and grinding plates. Put the cover on.



Caution:

Do not expose the stored stand mixer to extreme temperatures, direct sunlight, excessive humidity and do not place it in an excessively dusty environment. Do not place anything on the stored stand mixer.

TECHNICAL SPECIFICATIONS

Stand Mixer

Rated voltage range.....	220–240 V~
Rated frequency.....	50–60 Hz
Rated input.....	1,500 W
Volume of stainless steel container.....	5.5 l
Second stainless steel container volume.....	4.0 l
Glass blender container volume.....	1.5 l
Noise level.....	85 dB(A)

Scale

Power source.....	3× 1.5 V AAA batteries
Weight capacity (maximum load capacity).....	5 kg / 11 lb
Weighing accuracy.....	1 g / 0.1 oz
Choice of units.....	g/lb:oz

The declared noise emission level of the appliance is < 85 dB(A), which represents a level A of acoustic power with respect to a reference acoustic power of 1 pW.

SENCOR hereby declares that the radio device type STM 7651WS conforms to the 2014/53/EU directive. The full text of the EU Declaration of Conformity is available at: www.sencor.eu.

Values provided according to Commission Regulation EU 2023/826

Off mode	
Power consumption in off mode	0.5 W
Time needed for the equipment to automatically reach off mode	When inserting the main power supply: The device will automatically switch to shutdown mode after 18 minutes without any operation required. After running for one cycle: The device will automatically enter shutdown mode after 10 minutes without any operation required.
Standby mode	
Power consumption in Standby mode	W
Time needed for the equipment to automatically reach standby mode	min
Networked standby mode (Wi-Fi)	
Power consumption in networked standby	W
Time needed for the equipment to automatically reach networked standby mode	min

INSTRUCTIONS AND INFORMATION ON DISPOSAL OF USED PACKAGING MATERIAL

Dispose of used packaging material at the designated municipal waste disposal site.

DISPOSAL OF USED ELECTRICAL AND ELECTRONIC EQUIPMENT

Used electrical and electronic products must not be disposed of in ordinary municipal waste. To enable the proper disposal, renewal and recycling of these products, deliver them to the designated collection points. Alternatively, in some European Union states or other European countries the products can be returned to the local retailer when buying an equivalent new product. By disposing of this product correctly, you help to conserve valuable natural resources and prevent any potential adverse impact on the environment and human health that could result from improper waste disposal. For more details, contact your local authority or nearest collection point. Fines may be imposed for the improper disposal of this type of waste as per national regulations.

For business entities in European Union States

If you wish to dispose of electrical and electronic equipment, please request the necessary information from your retailer or supplier.

Disposal in other countries outside the European Union

To dispose of this product elsewhere, request the necessary information on the correct disposal method from local authorities or your retailer.

DISPOSAL OF USED BATTERIES

Batteries contain environmentally damaging compounds and therefore do not belong in standard municipal waste. Take used batteries for proper disposal at a designated battery collection point.

Changes to text and technical parameters are reserved.

FAST ČR, a.s.
U Sanitasu 1621
CZ-251 01 Říčany
www.sencor.com
info@sencor.cz