gorenje

GB IE

User manual
Installation instruction
Conversion instruction

BGH6xxA

BGH6xxB

BGR6xxA

BGR6xxB

Pictograms used:



Important information



Tip



Gas connection



Electrical connection



Right



Wrong

CONTENTS

Safety regulations

Safe use	4
Children and vulnerable people	7

User manual

Models	8
Description	8
Information according regulation (EU only) 66/2014	9
Before first use	10
During use	10
Cookware	11
Control	12
Accessories	13
Burner position	13
Cleaning	14
On/off- & Residual heat indicator	16
Faults table	17

Installation instruction

Safety regulations	18
Service	18
Preparations for installation	19
Sealing tape	20
Gas connection	21
Built in	21
Connecting & testing	21

Conversion instruction

Conversion instruction	22
Conversion table	22
Power table (kW-gr/h)	23
Converting nozzles	23
Converting by-pass screws	24
Check for gas tightness and operation	25
Start up	25
Checking operation	26

Environmental considerations

Disposal of packaging and appliance	27
-------------------------------------	----

READ CAREFULLY AND KEEP FOR FUTURE REFERENCE!

Safe use



- The manufacturer cannot be held liable for any damage resulting from failure to follow the safety instructions and warnings.
- Damage caused by incorrect connection, incorrect fitting, or incorrect use is not covered by the warranty.
- **WARNING:** this appliance and the accessible parts will become hot during use. Do not touch hot parts. Keep children younger than 8 away from the appliance unless they are under continuous supervision.
- **WARNING:** danger of fire: never leave anything on the hob.
- **CAUTION:** The cooking process has to be supervised. A short term cooking process has to be supervised continuously.
- **WARNING:** cooking with fat or oil on a hob without supervision can be dangerous and can lead to fire.
- **NEVER** try to extinguish a fire with water. Instead, switch the appliance off and then cover the flames with for example a lid or a fire blanket.
- Never flambé under a cooker hood. The high flames can cause a fire, even if the cooker hood is switched off.
- **WARNING:** use only hob guards designed by the manufacturer of the cooking appliance or indicated by the manufacturer of the appliance in the instructions for use as suitable or hob guards incorporated in the appliance. The use of inappropriate guards can cause accidents.
- The hob is only to be used for the preparation of food. The unit is not designed for heating rooms.
- Do not warm closed tins on the hob. There will be a build-up of pressure that will cause tins to explode. You might get injured or scalded.

SAFETY REGULATIONS

- Never cover the appliance with a cloth or something similar. If the appliance is still hot or is switched on, there is a risk of fire.
- Do not use the appliance as a worktop. The appliance may accidentally be switched on or still be hot, which means objects could melt, become hot or catch fire.
- Do not use the appliance in temperatures below 5 °C.
- The appliance should not be placed or used outdoors.
- When you use the hob for the first time you will notice a “new smell”. Don’t worry, this is normal. If the kitchen is well ventilated, the smell will soon disappear.
- The appliance is not intended to be operated by means of an external timer or separate remote control system.
- Never open the casing of the appliance.
- Never use a pressure cleaner or steam cleaner to clean the hob.
- The ceramic top is extremely strong, but not unbreakable. For example, a spice jar or sharp utensil falling on it could cause it to break.



- **WARNING** “In case of hotplate glass breakage”:
 - shut immediately off all burners and any electrical heating element and isolate the appliance from the power supply.
 - do not touch the appliance surface.
 - do not use the appliance.
- **CAUTION:** The use of a gas cooking appliance results in the production of heat, moisture and products of combustion in the room in which it is installed. Ensure that the kitchen is well ventilated especially when the appliance is in use. Keep natural ventilation holes open or install a mechanical ventilation device (mechanical extractor hood).

SAFETY REGULATIONS

- The burner components are hot during and immediately after use. Do not touch them, and avoid contact with non-heat resistant materials.
- The electric heating elements get very hot during use and also remain hot for some time after use. Do not allow small children near the hob during and soon after cooking.
- Never immerse hot burner caps and pan supports in cold water. The rapid cooling can damage the enamel.
- The distance between the pan and a knob or non-heat resistant wall should always be greater than two centimeters. In case of smaller distances the high temperature may cause the knobs or wall to discolour and/or deform.
- Always use the pan supports and suitable cookware.
- Always place the pan on the pan support. Placing the pan directly on the burner cap can result in dangerous situations.
- Aluminum trays or foil are not suitable as cooking utensils. They can burn into the burner caps and pan supports.
- The hob can only function effectively if the burner components have been assembled using the guide ridges. Ensure that the pan supports lie properly against each other and flat on the drip tray. Only then can the pans be positioned stably.
- Keep oven gloves or oven cloths away from the flame.
- Do not use griddle plates or baking plates.

Children and vulnerable people



- This appliance can be used by children aged 8 years and over, as well as by people with reduced physical, sensory or mental capabilities or lack of experience and knowledge, provided they are supervised and instructed in the safe use of the appliance and understand the hazards involved.
- Do not allow children to play with the appliance. Do not allow children to clean or maintain the appliance unless supervised.
- Do not keep objects that children might find interesting in cupboards above or behind the appliance.
- The heating elements/burners heat up during use and stay hot for a while afterwards. Keep young children away from the hob during and immediately after cooking.

Models

- Aa:**
Auxiliary burner
- Bb:**
Semi-rapid burner
- Cc:**
Rapid burner
- Dd:**
ø180 mm heating element
- Ee:**
ø145 mm heating element

BGH6xxA

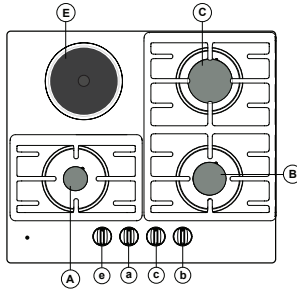

BGH6xxB

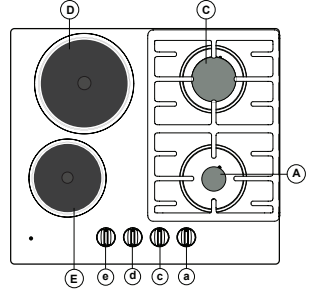

BGR6xxA

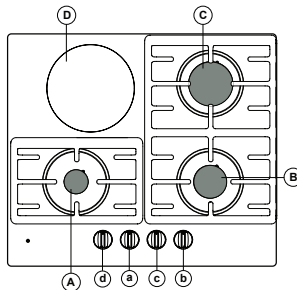

BGR6xxB

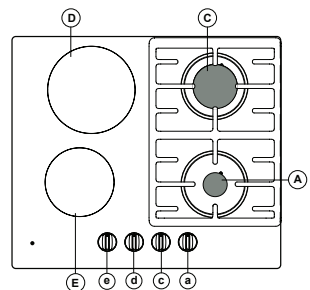

Description

Gas burners

G20 / 20 mbar			
	Burner	BGH6xxA BGR6xxA	BGH6xxB BGR6xxB
Aa	Auxiliary	1.00 kW	1.00 kW
Bb	Semi-rapid	1.80 kW	
Cc	Rapid	3.00 kW	3.00 kW
G30 / 30 mbar			
	Burner	BGH6xxA BGR6xxA	BGH6xxB BGR6xxB
Aa	Auxiliary	1.05 kW / 76 g/h	1.05 kW / 76 g/h
Bb	Semi-rapid	1.80 kW / 130 g/h	
Cc	Rapid	3.00 kW / 216 g/h	3.00 kW / 216 g/h

G30 / 50 mbar				
	Burner	BGH6xxA BGR6xxA	BGH6xxB BGR6xxB	Saudi Arabia
Aa	Auxiliary	1.05 kW / 76 g/h	1.05 kW / 76 g/h	76 g/h
Bb	Semi-rapid	1.90 kW / 137 g/h		130 g/h
Cc	Rapid	3.00 kW / 216 g/h	3.00 kW / 216 g/h	216 g/h

Electric heating element

Nominal Power (Max. heat setting) [W]					
	Heating element	BGH6xxA	BGH6xxB	BGR6xxA	BGR6xxB
Dd	ø 180 mm		2000	1800	1800
Ee	ø 145 mm	1500	1500		1200

Information according regulation (EU only) 66/2014

Measurements according EN60350-2 (G20-20 mbar)

Model identification		BGH6xxA	BGH6xxB	BGR6xxA	BGR6xxB
Type of hob		Mixed gas & electric hob			
Number of electric heating elements		1	2	1	2
Heating technology per electric heating elements		Solid plates		Radiant heating elements	
Diameter electric heating element	Large heating element:		Ø 180 mm		Ø 180 mm
	Small heating element:	Ø 145 mm	Ø 145 mm	Ø 180 mm	Ø 145 mm
Energy consumption per kg (E _{Electric cooking})	Large heating element:		193.6 Wh/kg	182.9 Wh/kg	189.7 Wh/kg
	Small heating element:	184.3 Wh/kg	190.4 Wh/kg		189.9 Wh/kg
Number of gas fired burners		3	2	3	2
Energy efficiency per gas burner (E _{Gas burner}) in %	Semi-rapid burner:	58.8		58.8	
	Rapid burner:	56.3	56.3	56.3	56.3

Before first use

BGH6xxA/B:

- Turn on the electric heating elements (**without a pan**) for 3-5 minutes at maximum power. During this time, the protective coating forms a durable layer on the electric heating elements. There may appear some smoke the first time the elements are heating up.

BGR6xxA/B:

- Clean the heating elements with a damp cloth.
- Turn on the electric heating elements (**without a pan**) for 3-5 minutes at maximum power.

During use

BGH6xxA/B

- Stainless steel parts around the electric heating elements may discolor due to the thermal load during cooking.



After turning the electric heating elements off it will remain hot for a prolonged period of time. Avoid contact with the electric heating elements during this time.

BGR6xxA/B:

- The temperature of the heating elements is internally controlled by constantly switching the element on and off. When the heating element is turned on, a clear red glow is present. When the heating element is set to a low heating setting, the element is switched off more frequently and for a longer period of time.



After turning the electric heating elements off it will remain hot for a prolonged period of time. This is indicated by the residual heat indicator. Avoid contact with the electric heating elements during this time.

Cookware

Gas burners

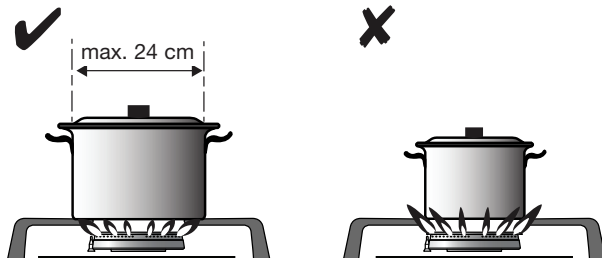

Electric heating elements

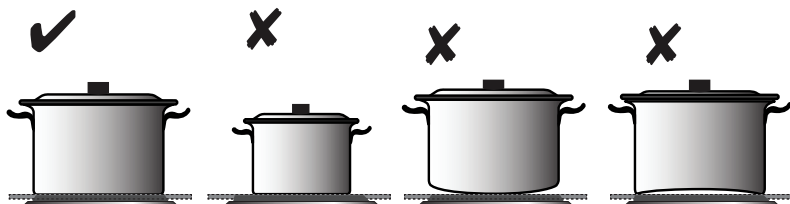

BGH6xxA/B & BGR6xxA/B

- Always keep a minimum distance of 1 cm between the control knobs and a pan.
- Always keep the pans within the edges of the hob.
- The bottom surface of the pans and the electric heating elements should always be clean and dry to ensure good heat conduction and prevent damage to the cooking surface.
- When cooking in a pot made of refractory and heat-resistant glass or porcelain, follow the instructions of the manufacturer.
- Make sure the pan always has enough fluids in them. Empty pans may cause the hob to overheat, resulting in a damaged worktop or hob.

BGR6xxA/B

- Do not use pans with a rough bottom as they may scratch the cooking surface.
- Sand (e.g., vegetables) may scratch the cooking surface.
- Do not move the dish on the cooking surface, this may result in scratches.
- The cooktop is solid but not resistant to pinpoint strikes. Make sure that no hard and/or sharp objects fall on it as it may damage the surface.
- Sugar and sweet foods can greatly damage the glass ceramic surface. Remove them immediately with the scraper to avoid damage to the surface, even if the hob is still warm.
- Do not cook on the cooking surface in a thin-walled aluminum pan and foil, as well as plastic containers. These materials can melt and damage the hob.

Control

BGH6xxA/B & BGR6xxA/B Control of gas burners

- (1) Push
- (2) Turn left + hold
- (3) Hold down 3 sec.

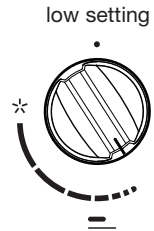
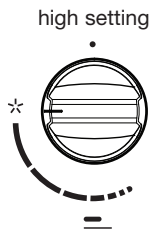
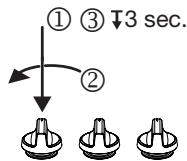

BGH6xxA/B Control of electric heating elements

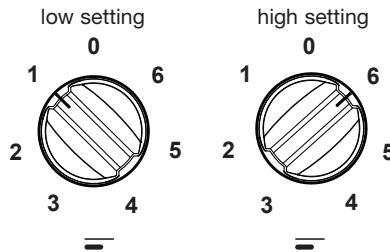

BGR6xxA/B Control of electric heating elements

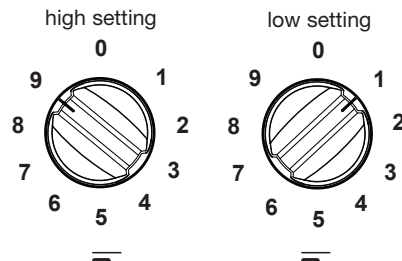

Accessories

**Suits Auxiliary
burner:**

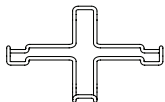

Burner position

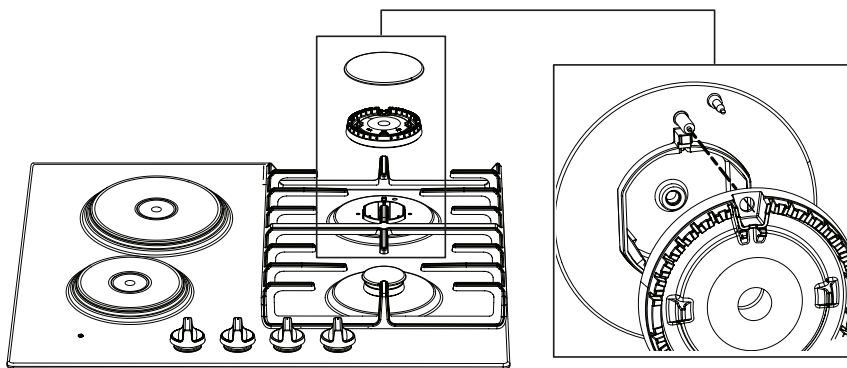

Cleaning

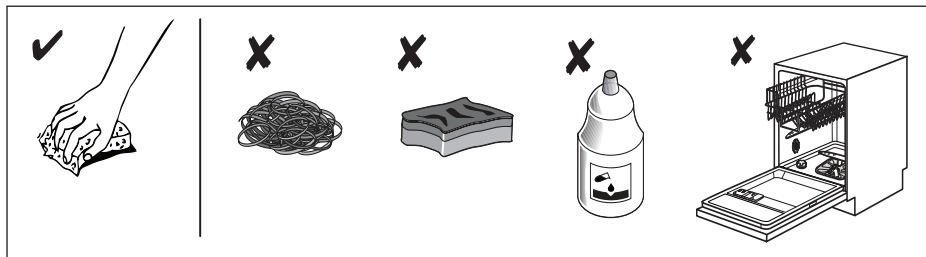

We recommend that you clean the appliance after each use. This prevents that over cooked food can damage the glass surface.

BGH6xxA/B

Daily cleaning

- Use warm water with some dishwashing detergent to clean the area around the electric heating elements. Before doing so, use a sponge to soften any stubborn residues.

Heavy polluted electric heating elements

- All dirty heating elements should be cleaned thoroughly immediately after use, when the heating elements are cooled down. If the heating elements are less stained, it suffices to wipe them with a damp cloth soaked in water and some detergent. If the element is heavily soiled, use a steel sponge (wire scrubber) soaked with detergent. After cleaning, the heating elements should always be wiped dry.
- Salt-containing liquids, dishes that have boiled over, or moisture, can damage the heating elements. Therefore, always wipe the heating elements clean and dry.

Maintenance

- To condition the electric heating elements, occasionally use some sewing machine oil, or conventional products for cleaning and care, available in the market. Never use butter, bacon / lard, or similar substance (risk of corrosion). If the heating element is slightly warm, the detergent will penetrate the pores more quickly.

BGR6xxA/B

Daily cleaning

1. Use a damp cloth and a mild cleaning agent (washing-up liquid) to clean the appliance.
2. Dry the appliance with a paper towel or a cloth.

Heavily polluted glass

1. Immediately remove any food remains, burned grease, sugar or stubborn stains from the glass ceramic hob using a scraper, even if the hob is still hot! Sugar and/or other food related remains may permanently damage the glass ceramic surface.
 - Hold the scraper at the correct angle (45° to 60°) in relative to the glass. Gently press the scraper against the glass and slide it over the surface to remove the dirt. Make sure the plastic handle of the scraper (in some models) does not come into contact with a hot heating element.
 - Do not press the scraper perpendicularly against the glass.
 - Do not scratch the hob surface with the tips of the scraper blade. This can cause permanent scratches in the glass.
2. After you have removed the stubborn stains from the glass, use the steps of the daily cleaning to clean the hob.
3. If the cleaning results is not at your satisfaction you can repeat the above cleaning steps as often as needed.



Do not use abrasive cleaning agents, because they can cause scratches.

Do no use steel wool, scourers or any type of sharp objects to clean the appliance

The hob can still be very hot due to the cooking process! Do not touch the surface directly. If desired use gloves to prevent burning while cleaning directly after cooking.

On/Off- & Residual heat indicator

BGH6xxA/B:

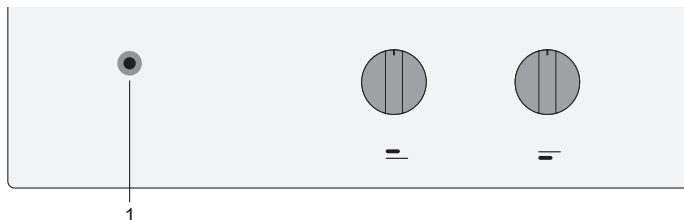

1. On/Off indicator:

Indicates whether one or multiple heating elements are turned on.



Warning! If the heating element is turned off, the On/Off indicator will also turn off.

However, the electric heating elements will remain hot for a prolonged period of time after turning off. **Risk of injury when touching the hot heating element during this time.**

BGR6xxA/B:

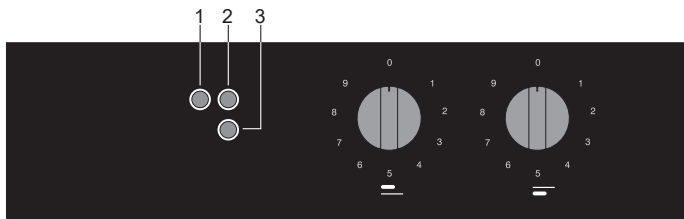

1. On/Off indicator:

Indicates that one or multiple heating elements turned on.

2. Residual heat indicator rear heating element:

Indicates that the rear heating element is (still) hot.

3. Residual heat indicator front heating element:

Indicates that the front heating element is (still) hot.



Warning! Risk of injury when touching the hot heating element.

Faults table

Following is some advice on rectifying some common problems.

What happened...?	Possible cause	What to do?
The burners will not burn. The flame is uneven / unstable.	Flame is uneven due to a wrong gas power setting.	Have an expert check the gas pipeline!
The flame from the burners suddenly changes.	Wrongly assembled parts of the kitchen hob.	Assemble the burner correctly.
Burner ignition takes more time.	Wrongly assembled parts of the kitchen hob.	Assemble the burner correctly.
The flame is extinguished shortly after ignition.	Knob pressed too short or too weakly.	Keep the knob pressed for a longer period of time.
The grid has discolored in the burner area?	This is a commonplace phenomenon resulting from high temperature.	Clean the grid with a metal care detergent.
Electric power supply in general is interrupted?	The fuse may be blown.	Check the fuse in the fuse box and replace it if it is blown.
Electric ignition of the burners no longer works?	There are food or detergent residues between the spark plug and the burner.	Open and carefully clean the opening between the spark plug and the burner.
The burner cover looks unappealing.	Regular dirt.	Clean the burner covers with a metal care detergent.
A slight smell is noticeable the first time electric heating elements are used.	The new appliance is heating up.	This is normal and will disappear once it has been used a few times. Ventilate the kitchen.



A visit by a service technician during the warranty period will be charged if the appliance is not functioning because of improper use. Store these instructions in a place where they are always readily accessible; if you pass the appliance on to another person, the instructions should also be included.



If the problem persists despite observing the instructions above, call an authorized service technician. Elimination of any errors or warranty claims that resulted from improper connection or use of the appliance is not covered by our warranty. In such cases, the costs of repair are borne by the user.

INSTALLATION INSTRUCTION

Safety regulations



- This appliance should only be connected by a registered installer.
- Prior to installation, ensure that the local distribution conditions (voltage, frequency, nature of the gas and gas pressure) and the adjustment of the appliance are compatible.



- This Appliance must be earthed.
- The voltage, frequency, power, type of gas and the country for which the appliance has been designed are shown on the appliance rating plate.
- The electrical connection must comply with national and local regulations.
- The wall plug socket and plug should always be accessible.
- If a stationary appliance is not fitted with a supply cord and a plug, or with other means for disconnection from the supply mains having a contact separation in all poles that provide full disconnection under overvoltage category III conditions, the means for disconnection must be incorporated in the fixed wiring in accordance with the wiring rules. Using an omnipolar switch with a contact separation of at least 3 mm fitted in the supply cable will fulfil this requirement.



- The connection cable must hang freely and should not be fed through a drawer.
- Gas connection 1/2" ISO 228 / ISO 7-1 / EN 10226-1 (1/2" ISO 228 / 1/2" ISO 228 FR only).
- The gas connection must comply with national and local regulations. See appliance label for technical gas data.
- This appliance is not connected to a combustion products evacuation device. It shall be installed and connected in accordance with current installation regulations.
- Particular attention shall be given to the relevant requirements regarding ventilation.
- We recommend that the gas hob be connected by means of a fixed pipe. Connection using a specially designed safety hose is also permitted.
- The pipe behind the oven must be made entirely out of metal.
- A safety hose may not be bent and must not come into contact with moving parts of kitchen units.
- The gas supply valve must always be placed in an easily accessible position.
- The worktop into which the hob is fitted should be flat.
- The walls and the worktop surrounding the appliance must be heat resistant up to at least 85 °C. Even though the appliance itself does not get hot, the heat of a hot pan could discolour or deform the wall.
- Bottom kitchen element must be equipped with a built-in horizontal shelf at a distance of not less than 15 cm from the bottom surface of the worktop. The space between the shelf and the cooktop must be empty and may not be used for storage of utensils.

Service



- Faulty parts may only be replaced by original parts. The manufacturer can only guarantee that original parts meet safety requirements.
- If the supply cord is damaged, it must be replaced by the manufacturer, its service agent or similarly qualified persons in order to avoid a hazard.

INSTALLATION INSTRUCTION

Preparations for installation

Free space around appliance:

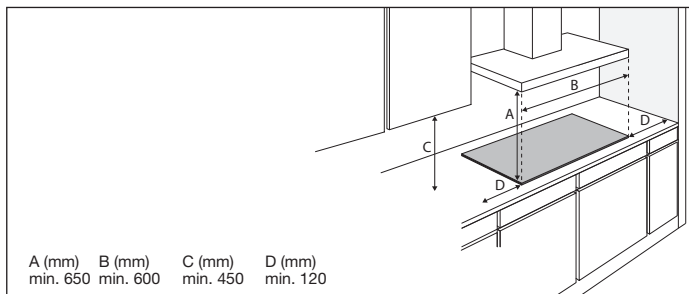

Appliance dimensions:

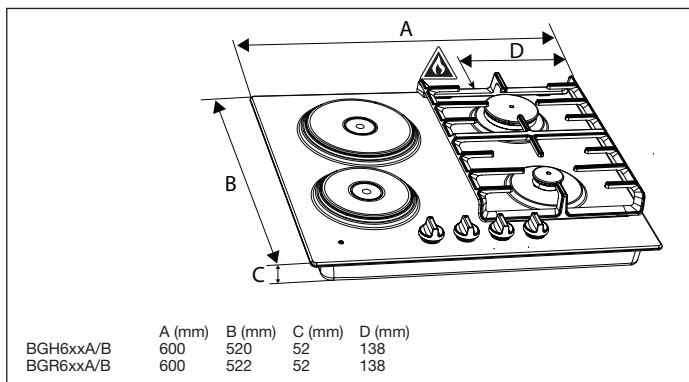

Built-in dimensions:

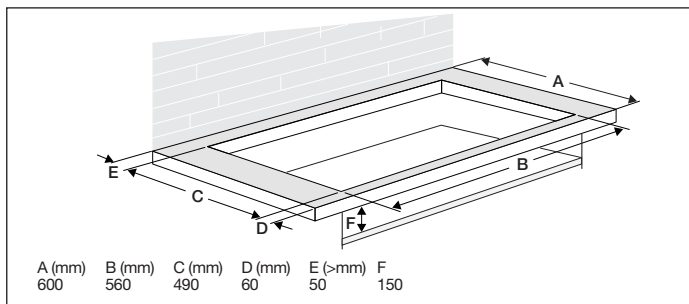

Warning:

Bottom kitchen element must be equipped with a built-in horizontal shelf at a distance of not less than 150 mm from the bottom surface of the worktop. The space between the shelf and the cooktop must be empty and may not be used for storage of utensils.

INSTALLATION INSTRUCTION

Accessibility

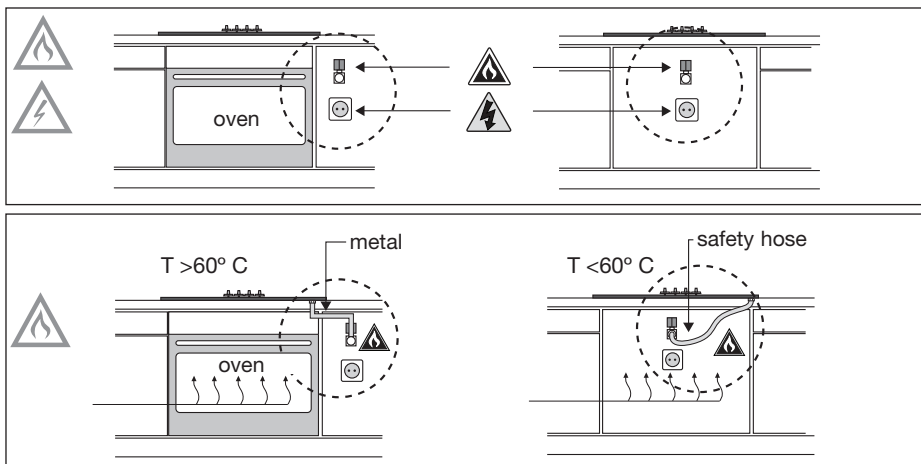

Sealing tape

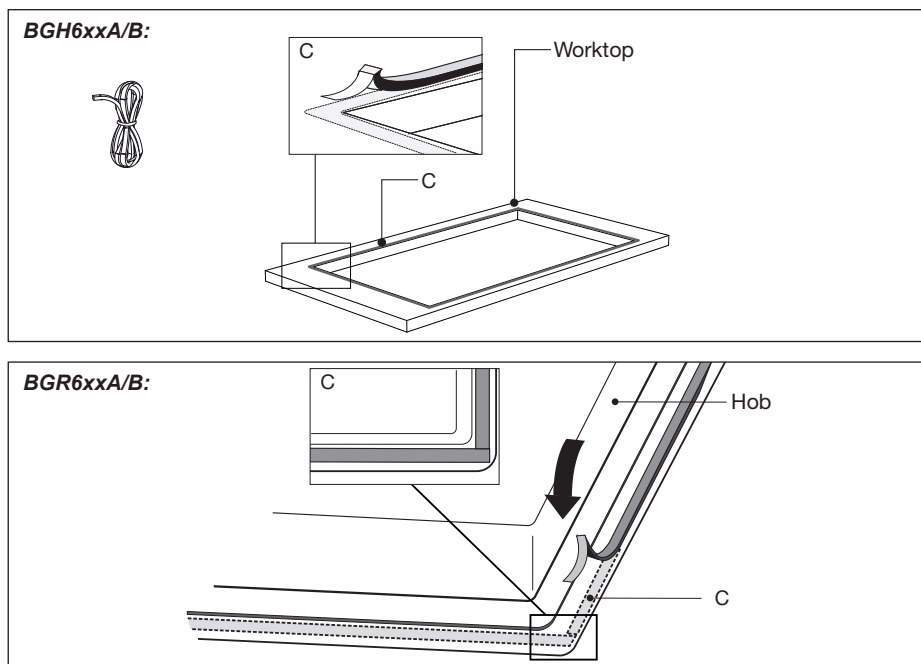

INSTALLATION INSTRUCTION

Gas connection

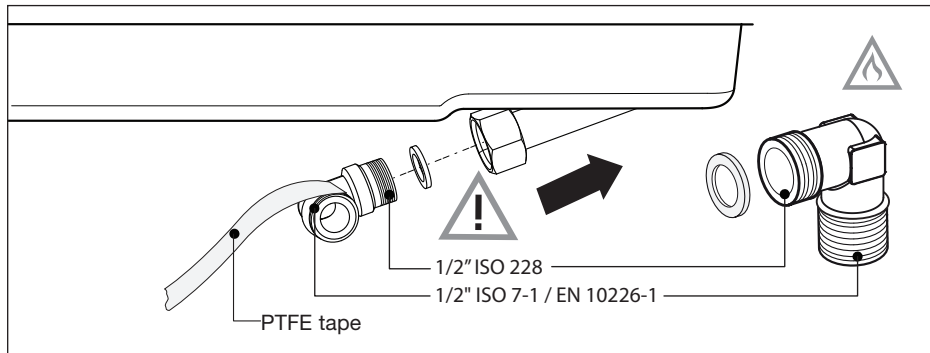

Built in

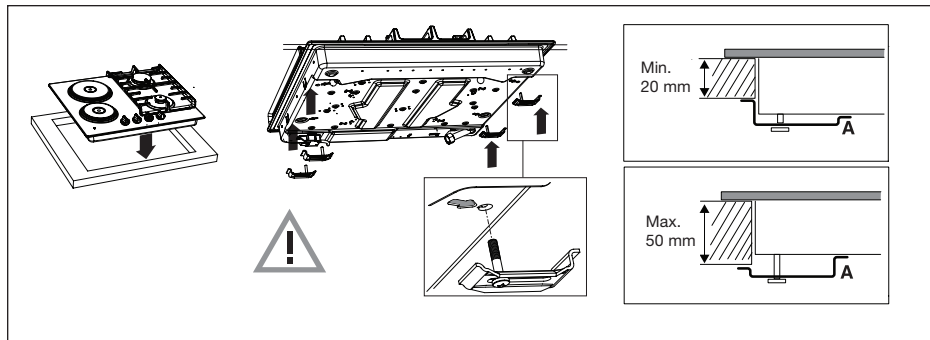

Connecting & testing

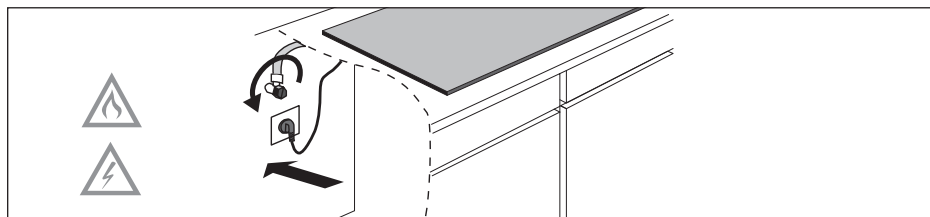

Check if connections are gastight.

CONVERSION INSTRUCTION

Conversion instruction



Adjusting for a different gas type!

Attention! Performing of these instructions by a non-qualified engineer can lead to dangerous situations. The supplier is not responsible for the consequences (the arising of a hazardous situation and/or damage to persons or goods) caused by incorrect performance of these instructions by engineers who are not employees of the supplier. Consequential damage arising through inexpert performance of these instructions is not accepted.

With this conversion-set your gas hob can be converted to different gasses.

See conversion Table.

Conversion table

Gas type	P mBar	Modification	Auxiliary	Semi rapid	Rapid
			nozzle	nozzle	nozzle
G20	20	-	72	97	128
Convert from G20 / 20 mbar to:					
G20	13	Replace nozzle & no action by-pass	84	115	145
G25	20	Replace nozzle & no action by-pass	77	105	134
G30/ G31	28- 30/37	Replace nozzle & screw in bypass (see 3A)	50	65	85
G150	8	Replace nozzle & adjust bypass (see 3C)	145	200	290
G30	50	Replace nozzle & screw in bypass (see 3A)	43	60	75

Gas type	P mBar	Modification	Auxiliary	Semi rapid	Rapid
			nozzle	nozzle	nozzle
G30	30	-	50	65	85
Convert from G30 / 30 mbar to:					
G20	20	Replace nozzle & adjust bypass (see 3C)	72	97	128

CONVERSION INSTRUCTION

Power table (kW-g/h):

	G20 13 mbar	G25 20 mbar	G30-G31 28-30/37 mbar	G30 50 mbar	Saudi Arabia G30 50 mbar	G150 8 mbar
Auxiliary burner	1.05	1.05	1.05/76	1.05/76	76 g/h	1.10
Semi-rapid burner	1.95	1.95	1.80/130	1.90/137	130 g/h	1.85
Rapid burner	3.10	3.10	3.00/216	3.00/216	216 g/h	3.00

Contents of conversion set

- Nozzles for burners and (if applicable) by-pass screws for gas taps.
- Data label with the modified gas specifications and setting.

Tools needed:

- T1 Socket spanner (7mm)
- T2 Screw driver flat blade (4mm)
- T3 Nose pliers
- T4 Leak test spray

Converting nozzles

 **Please note:** disconnect the appliance from the power supply. Prevent damage of the worktop. Lay down parts of the appliance on a protected base.

 For converting to a different type of gas, the nozzles have to be changed. The values are also marked on the nozzle.

1. Remove pan supports, burner heads, crowns and covers (see picture A1). Pull off the control knobs vertically.
2. Use the socket (T1) to remove the old nozzles and place the new nozzles inside the burner cups (see picture A1).

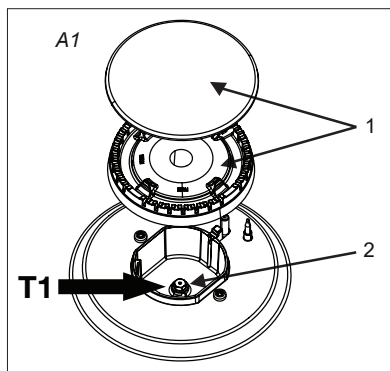

CONVERSION INSTRUCTION

Converting by-pass screws

Depending on the gas type to which the appliances will be converted, there are two ways to adjust the by-pass screws.

Please check the conversion table in the column “Modification”, if the by-pass screws have to be screwed completely in (see action 3A below), replaced by a different by-pass screw (see action 3B below) or adjusted (see action 3C below).

The values are also indicated on the top of the by-pass screws.

The by-pass screws can be reached from the top of the hob when the knobs are removed (B1 and B2).

- 3A. Screw the by-pass screws (3) of all gas taps completely in by using the flat-blade screwdriver (T2).
- 3B. Remove the by-pass screws by using the flat-blade screwdriver (T2) and the nose pliers (T3). Place the new by-pass screws with the nose pliers and screw the by-pass screws of all gas taps in, by using the flat-blade screwdriver.
- 3C. Adjust the by-pass screws (3) of all gas taps by using the flat-blade screwdriver (T2) until a stable flame is established with a minimal gas flow. Please check if the flame is stable in cold and hot condition of the burner.

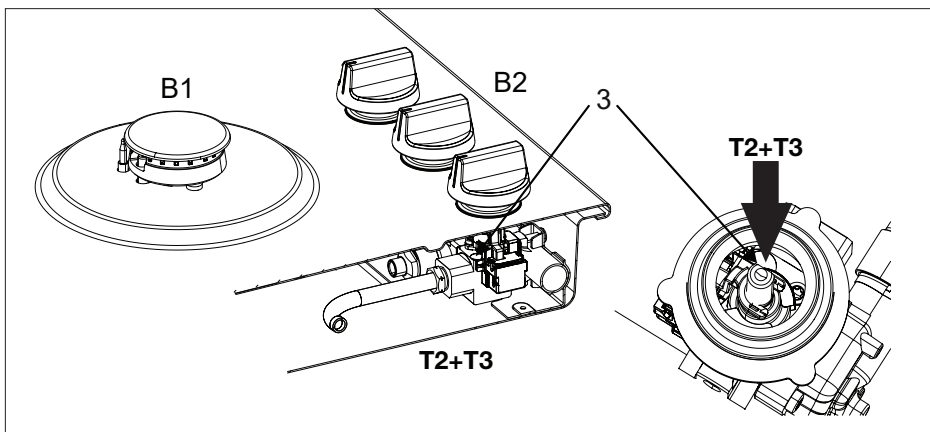

CONVERSION INSTRUCTION

Check for gas tightness and operation

When the appliance is connected to the gas supply, use leak test spray to check the gas tightness:

1. Seal the injector.
2. Open the gas tap.



Attention: press and open tap to override the thermo-electric safety device and keep it pressed down.

3. Spray leak test spray over all gas connections and check for gas tightness.
4. Repeat this for every burner.

Start up

1. Reinstall the knobs, burner parts and pan supports.
2. Check if the appliance is connected to the correct gas type and pressure.
3. Open the main gas valve.
4. Insert the plug into the power socket.

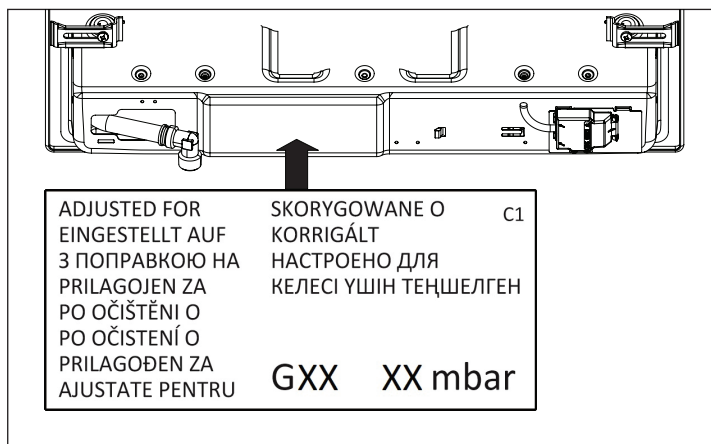

Checking operation

1. Ignite the burners.
2. Check whether the flame profile is normal, uniform and stable for the complete ratio:
 - Check if the flame does not smother in simmer rate;
 - Check if the flames are not 'blowing off' at maximum rate;
 - No long, yellow flames should be visible during operation.
3. Paste the data label with the modified gas specifications and setting over the current data label with old specification (at the under site of the appliances nearby the gas connection).

Disposal of the appliance and packaging

Sustainable materials have been used during manufacture of this appliance.

The appliance packaging is recyclable. The following may have been used:

- cardboard;
- paper;
- polyethylene film (PE);
- CFC-free polystyrene (PS-rigid foam);
- polypropylene tape (PP).

Dispose of these materials in a responsible manner and in accordance with government regulations.

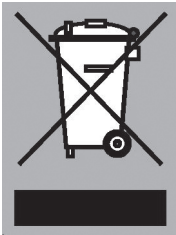

To designate the requirement for separate collection of household electrical appliances, the symbol of a crossed-out dustbin is applied to the product.

This means that at the end of its working life, the product must not be disposed of as urban waste. It must be taken to a special local authority differentiated waste collection centre or to a dealer providing this service. Disposing of a household appliance such as this hob separately avoids possible negative consequences for the environment and health and enables the constituent materials to be recovered, resulting in significant savings in energy and resources.



Please note! Do not throw a broken ceramic glass plate in the glass recycling bin but take this to the Municipality's waste recycling centre.



Declaration of conformity

We hereby declare that our products satisfy the applicable European directives, orders and regulations, as well as the requirements stated in the referenced standards.

Gorenje gospodinjski aparati, d.o.o.

Address: Partizanska 12, 3320 Velenje, Slovenia

Phone: +386 (0)3 899 10 00

Fax: +386 (0)3 899 28 00

www.gorenje.com

gorenje



797176

en (09-19)