



F R I E D R I C H

PTAC
Packaged Terminal Air
Conditioners & Heat Pumps

FreshAire™

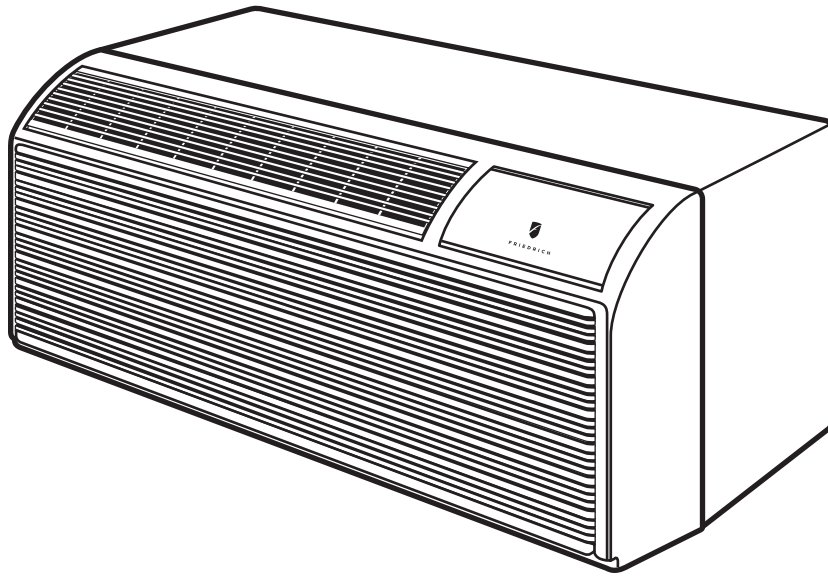

Table of Contents

Congratulations	3
General Instructions	3
General Specifications	4
PTAC Installation Recommendations	5
Wall Sleeve Installation Instructions (PDXWSA)	6
Alternate Wall Installations	7
PXDR10 Drain Kit Installation Instructions (optional for new construction)	10
External Drain (for new construction or unit replacement)	11
PXGA Standard Grille Installation Instructions	12
Chassis Install Preparation	16
Chassis Installation	18
Friedrich PTAC Digital Control and Unit Features	19
System Configuration	21
Digital Control User Input Configuration	22
Digital Control Operation	24
Remote Control Thermostat Installation	26
Remote Thermostat and	26
Low Voltage Control Connections	26
Final Inspection & Start-up Checklist	28
Basic Troubleshooting	29
Service & Assistance	31
Accessories	32

NOTE:

All PTAC 9000units come with a universal 2.5+1.0kW electric heater(standard 20A power cord for 3.5kW ,optional 15A power cord for 2.5kW). All PTAC 12000units come with a universal 3.5+1.5kW electric heater(standard 20A power cord for 3.5kW,optional 30A power cord for 5kW,optional 15A power cord for 1.5kW).





Congratulations

Thank you for your decision to purchase Friedrich. Your new Friedrich has been carefully engineered and manufactured to give you many years of dependable, efficient operation, maintaining a comfortable temperature and humidity level. Many extra features have been built into your unit to assure quiet operation, the greatest circulation of cool, dry air, and the most economic operation.

General Instructions

This Installation and Operation Manual has been designed to insure maximum satisfaction in the performance of your unit. For years of trouble-free service, please follow the installation instructions closely. We cannot overemphasize the importance of proper installation.



 WARNING	
	<p>Refrigeration system under high pressure</p> <p>Do not puncture, heat, expose to flame or incinerate.</p> <p>Only certified refrigeration technicians should service this equipment.</p> <p>R32 systems operate at higher pressures than R22 equipment. Appropriate safe service and handling practices must be used.</p> <p>Only use gauge sets designed for use with R32. Do not use standard R22 gauge sets.</p>





Here are some suggestions to help you use your new Friedrich most efficiently:

1. Carefully read and follow the installation instructions.
2. Make sure the unit is the right capacity for the area being cooled. An undersized unit makes the unit work too hard, using more electricity than needed and increases wear. An oversized unit will cycle on and off too rapidly, and therefore cannot control humidity as well.
3. Clean the filter frequently (See Routine Maintenance, Page 27).
4. Do not block the air flow to and from the unit.
5. A dirty filter or improperly set controls can affect the cooling ability of the unit.
6. If cooling is weak and you have verified that the filter is clean

and the controls are properly set, the unit may need service and you should call your Friedrich service provider to check the unit.

7. Keep blinds, shades and drapes closed on the sunny side of the room being cooled to reduce radiant heat.
8. Proper insulation helps your unit maintain the desired inside temperature.
9. Whenever possible, shade south and west facing windows.
10. Keep window coverings away from the unit to provide free air flow.

 WARNING	
	<p>Read Installation Operation Manual</p> <p>Please read this manual thoroughly prior to equipment installation or operation.</p> <p>It is the installer's responsibility to properly apply and install the equipment. Installation must be in conformance with the NFPA 70 -2008 National Electric Code or current edition, International Mechanic Code 2009 or current edition and any other applicable local or national codes.</p> <p>Failure to do so can result in property damage, personal injury or death.</p>

Your safety and the safety of others are very important.	
<p>We have provided many important safety messages in this manual and on your appliance. Always read and obey all safety messages.</p>	
	<p>This is a safety Alert symbol.</p> <p>This symbol alerts you to potential hazards that can kill or hurt you and others.</p> <p>All safety messages will follow the safety alert symbol with the word "WARNING" or "CAUTION". These words mean:</p>
 WARNING	<p>Indicates a hazard which, if not avoided, can result in severe personal injury or death and damage to product or other property.</p>
 CAUTION	<p>Indicates a hazard which, if not avoided, can result in personal injury and damage to product or other property.</p>
<p>All safety messages will tell you what the potential hazard is, tell you how to reduce the chance of injury, and tell you what will happen if the instructions are not followed.</p>	
 NOTICE	<p>Indicates property damage can occur if instructions are not followed.</p>

General Specifications

Typical Unit Components and Dimensions

PDXWS Wall Sleeve
 Dimensions: 16" H x 42" W x 13-3/4" D
 Front Cover Dimensions:
 16" H x 42" W x 7-3/4" D

Cut-Out Dimensions:
 16-1/4" x 42-1/4"

PTAC/PTHP Model Identification Guide

<p>MODEL NUMBER</p> <p style="text-align: center; font-weight: bold; font-size: 1.2em;">P V H 09 K 3 F A</p> <div style="border: 1px solid black; padding: 5px; margin-bottom: 5px;"> <p>Series PV = Friedrich Digital PTAC</p> </div> <div style="border: 1px solid black; padding: 5px; margin-bottom: 5px;"> <p>System E = Cooling with electric heat H = Heat Pump with Auxiliary Heat</p> </div> <div style="border: 1px solid black; padding: 5px; margin-bottom: 5px;"> <p>Nominal Capacity 07 = 7,000 Btuh 12 = 12,000 Btuh 09 = 9,000 Btuh 15 = 15,000 Btuh</p> </div> <div style="border: 1px solid black; padding: 5px;"> <p>Voltage K = 230/208V - 1 Ph. - 60 Hz. R = 265V - 1 Ph. - 60 Hz.</p> </div>	<div style="border: 1px solid black; padding: 5px; margin-bottom: 5px;"> <p>Engineering Digit</p> </div> <div style="border: 1px solid black; padding: 5px; margin-bottom: 5px;"> <p>Design Series</p> </div> <div style="border: 1px solid black; padding: 5px; margin-bottom: 5px;"> <p>Chassis F = FreshAir</p> </div> <div style="border: 1px solid black; padding: 5px;"> <p>Nominal Heater Size (230V or 265V) 3=3kW</p> </div>
---	---

Installation Checklist

- Inspect all components and accessories for damage before and after installation.
- Remove the cardboard wall sleeve support and grill weatherboard.
- Check for proper wall sleeve installation in accordance with the wall sleeve installation instructions.
- Check for a subbase kit or other means of structural support which is required for ALL installations projecting more than 8" into room.
- Install the recommended Condensate Drain Kits for complete condensate removal.
- Ensure that the chassis is installed in a 16" highx4" wide wall sleeve that is no deeper than 13-3/4". A baffle kit is required if the sleeve exceeds that depth.
- Ensure that chassis and chassis front cover are installed and secured properly.
- Ensure that drapes, bed, bedspread, furniture, etc DO NOT block either return or discharge air grilles.
- Inspect the condenser air inlet and outlet for any obstructions (shrubby, etc).
- Ensure that 'reset' button is pressed on LCD device (only on cord connected models).



PTAC Installation Recommendations

For proper PTAC unit performance and maximum operating life refer to the minimum installation clearances below:

Figure 1

PTAC units should be installed no closer than 12" apart when two units are side by side. If three or more PTAC units are to operate next to one another allow a minimum of 36" between units. Also, a vertical clearance of 60" should be maintained between units installed. In the interior of the room the unit should be located a minimum of 1/4" from the floor and a minimum of 36" from the ceiling.

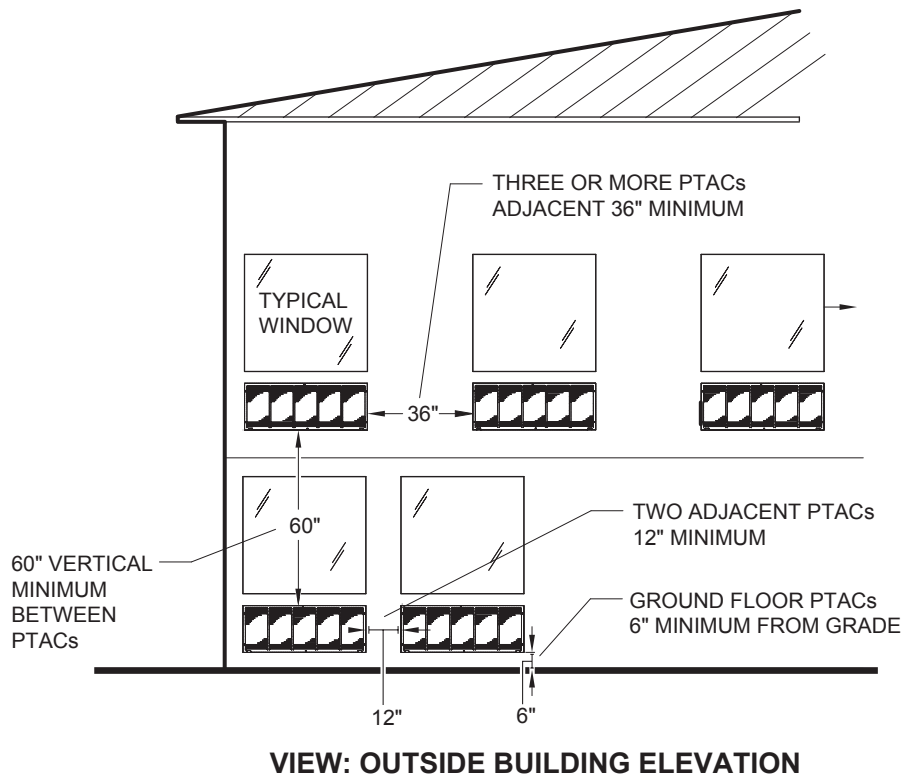

FRP001

For PTACs on the ground floor or anytime obstructions are present, use the following guidelines:

Figure 2

- For minor obstructions such as lamp poles or small shrubbery a clearance of 12" from the outdoor louver should be maintained.
- For major obstructions such as a solid fence, wall or other heat rejecting device like a condensing unit, a minimum distance of 36" should be kept.

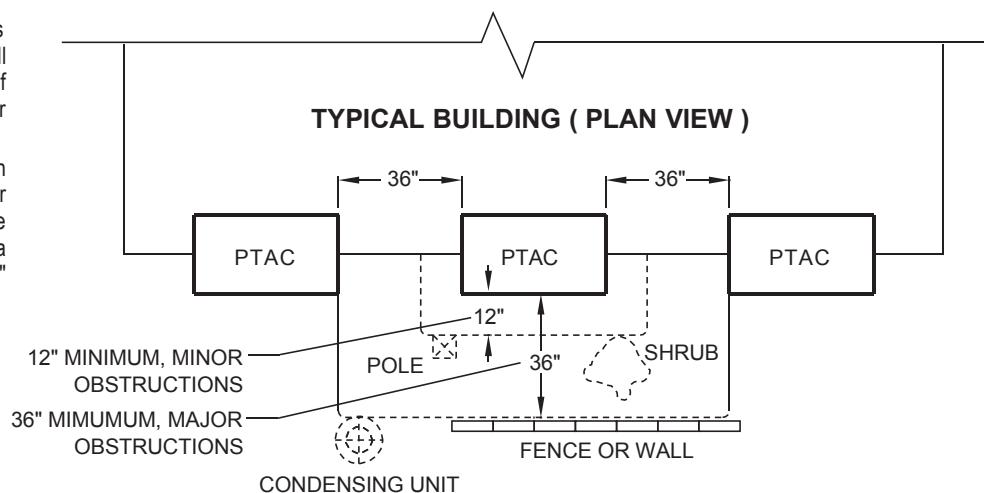

FRP002

The above suggestions are for reference only and do not represent all possible installations. Please contact Friedrich for information regarding affects of other installation arrangements. By following these simple recommendations you can be confident that your Friedrich PTAC will provide years of worry free operation.

Wall Sleeve Installation Instructions (PDXWSA)

NOTE: Insure that the unit is only installed in a wall structurally adequate to support the unit including the sleeve, chassis and accessories. If the sleeve projects more than 8" into the room, a subbase or other means of support **MUST** be used. Please read these instructions completely before attempting installation.

 WARNING	
	<p>Falling Object Hazard</p> <p>Not following Installation Instructions for mounting your air conditioner can result in property damage, injury, or death.</p>

NOTICE
<p>DO NOT allow any pitch toward the inside.</p> <p>Flashing on all 4 sides of the opening is recommended.</p> <p>Potential property damage can occur if instructions are not followed.</p>

For Deep Wall Installation (Greater than 13 1/4")
See Page 9

The following instructions apply **ONLY** to walls less than 13 1/4" in depth.

- 1 The PXDR10 Drain Kit, (optional for new construction) see page 10 if applicable, must be installed before the wall sleeve is installed into the wall.
- 2 The External Drain (for new construction or unit replacement) see page 11 if applicable, must be installed before the wall sleeve is installed into the wall.
- 3 From inside the building, position the wall sleeve in the opening and push it into the wall until it protrudes at least 1/4" on the outside (See Figure 9, Page 8).
- 4 Position the wall sleeve with a slight tilt towards the outside to facilitate condensate drainage. It should be level side-to-side and the front should be 1/4" bubble higher than the back.

Figure 3
Typical Wall Sleeve Installation

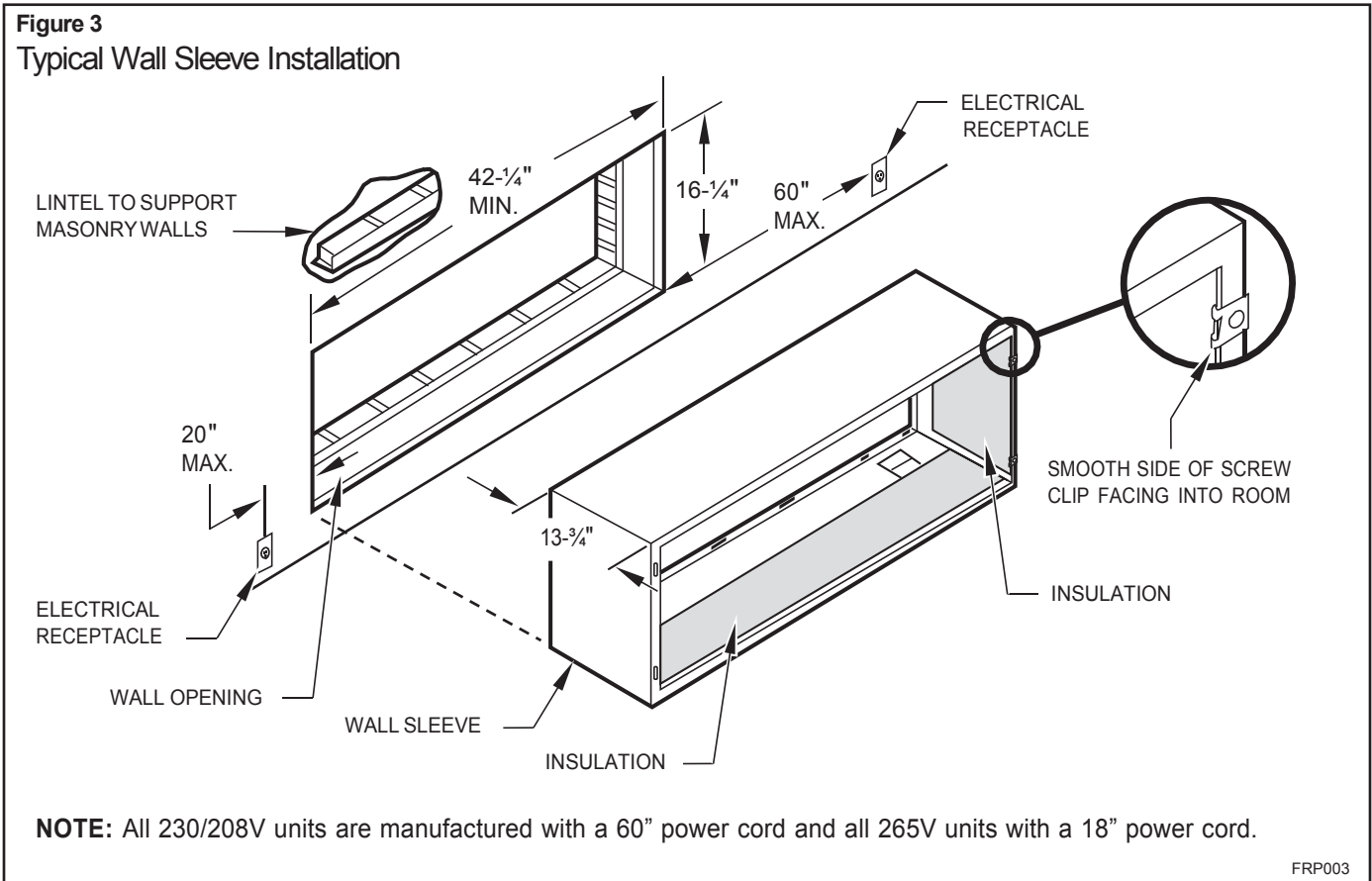

Alternate Wall Installations

Figure 4
Panel Wall

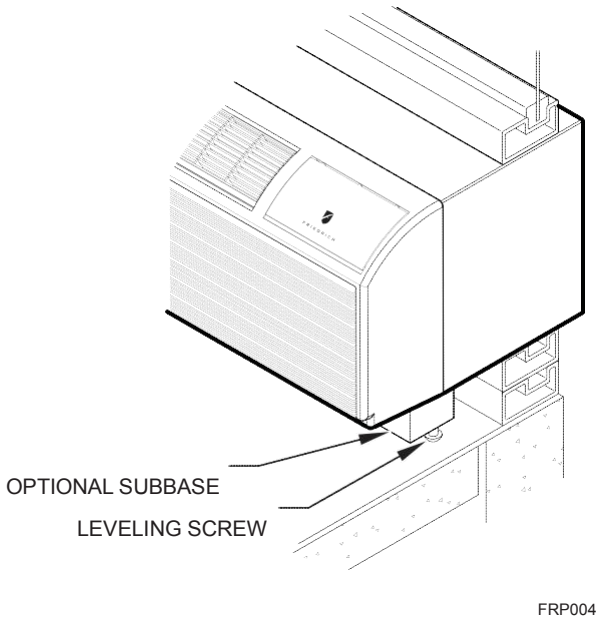

Figure 6
Curtain Wall

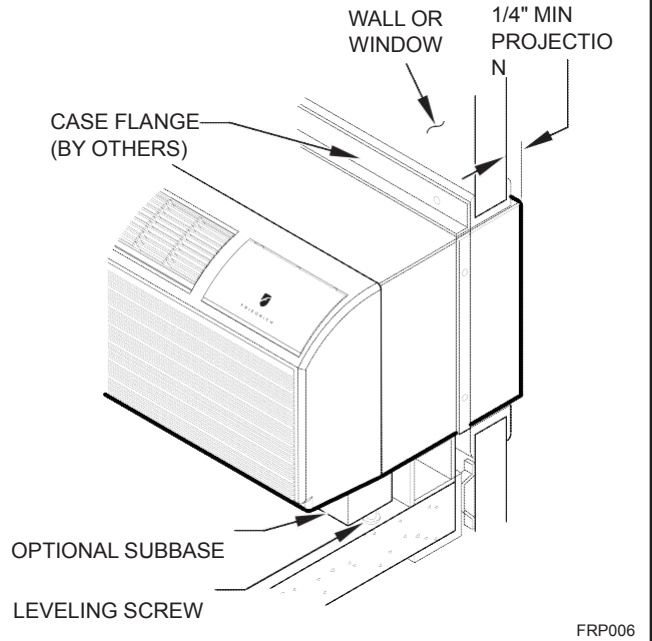

Figure 5
Frame and Brick Veneer

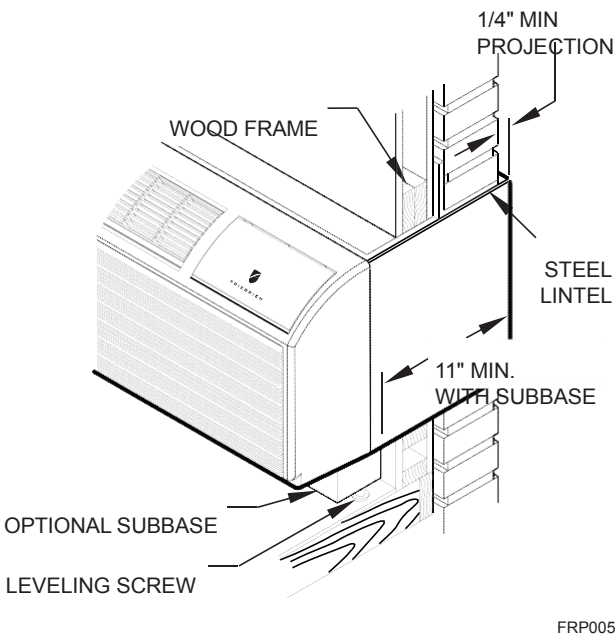
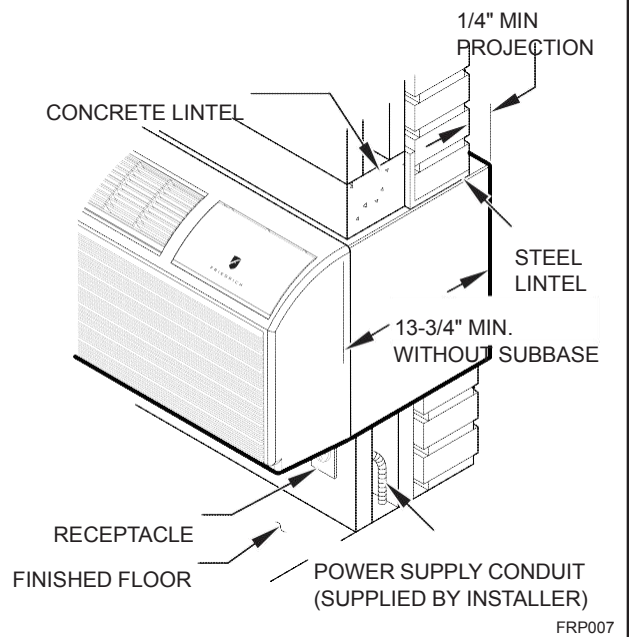

Figure 7
Block and Brick Veneer



NOTE: Follow all wall system manufacturer installation instructions. For sunrooms and modular buildings, adhere to their installation instructions for supporting and sealing sleeve to their frames. All wall and window/wall installations must provide for proper drainage. In applications where the drain holes on the PTAC wall sleeve are not exposed beyond the wall an internal drain system is recommended. It is the installer's responsibility to ensure there is adequate drainage for the PTAC unit.



Figure 8
Wall Sleeve Attachment

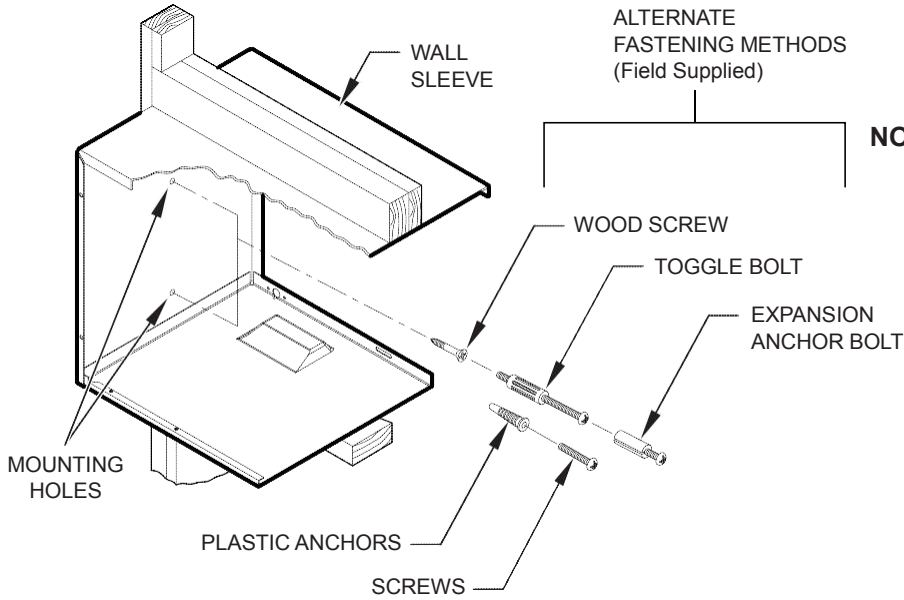

NOTE: The Wall Sleeve must be horizontally level (side-to-side) and pitched 1/4 bubble to the outside when installed in an opening. The mounting hole location should be approximately 2-4" from the top and bottom of the sleeve.

FRP008

Figure 9
Dimensions

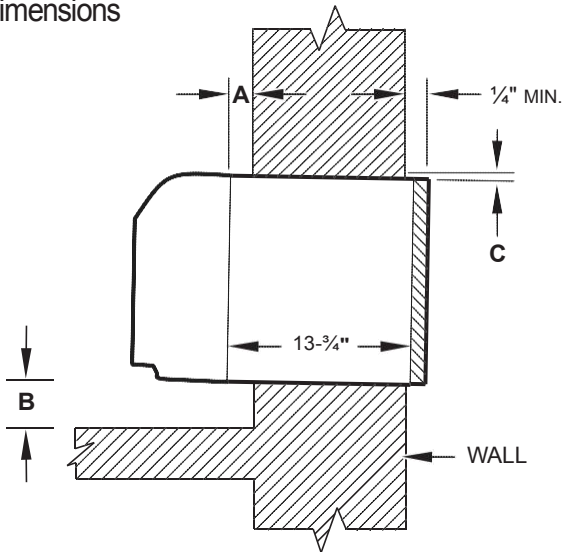

Dimension*	A	B		C
	Allow for wall finishing (Minimum)	Allow for floor finishing Min.	Max.	Allow for proper drainage (Front-to-Back)
No Accessories	1/4"	1/4"	---	---
With Subbase	1-3/4"	3-1/2"	5"	---
With Lateral Duct	3/4"	1/4"	---	---
Wall Sleeve Tilt	---	---	---	1/4"

* If more than one accessory is to be used, use the maximum dimension. If the wall thickness is more than 13-3/4" - (A+ 1/4"), a sleeve extension must be used.

FRP009

5. Drill two 3/16" holes through each side of the sleeve approximately 4" from top and 4" from bottom of sleeve. Screw four #10 x 1" screws (included) or appropriate fasteners for your installation, through the holes in the sides of the wall sleeve.
6. Apply sealant around the wall sleeve where it projects through the inside and outside wall surfaces. Apply the sealant to the screw heads or the tops of the fasteners used in Step #5.
7. If the chassis and exterior grille are to be installed later, leave the weatherboard and center support in place, otherwise remove and dispose of them. (See Figure 13, Page 12).
8. Provide a support lintel if the wall sleeve is installed in a concrete or masonry wall (See Figure 10, Page 9).

Figure 10
Lintel Installation

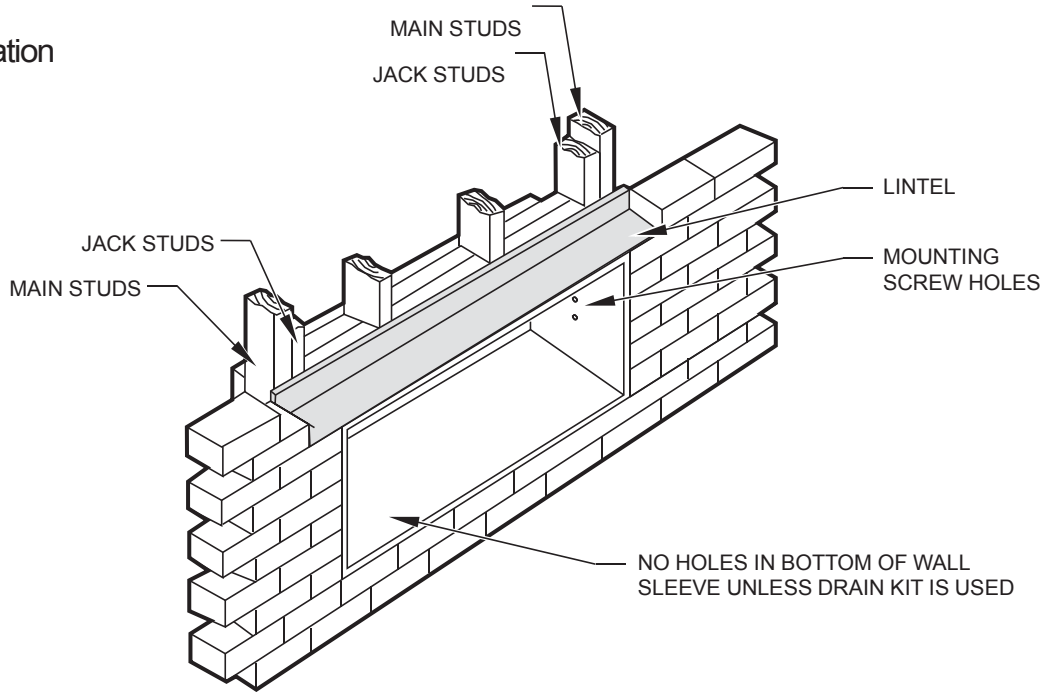

NOTE: Construct wall opening to comply with all applicable building codes.

FRP010

One-Piece Deep Wall Sleeve Installation (PDXWSEXT)

If the wall is thicker than 13 1/4" a deep wall sleeve or wall sleeve extension **MUST** be used. The deep wall sleeve may be special ordered through your Sales Representative.

PXDR10 Drain Kit Installation Instructions (optional for new construction)

NOTE: Determine whether drain will be located within the wall, on the indoor side, or will drain to the exterior of the building. Follow appropriate instructions below depending on your particular type of installation.

Internal Drain

NOTE: If installing an internal drain, you MUST install a drain kit on the wall sleeve before the wall sleeve is installed.

1. Refer to Figure 11 and locate the drain within the "Preferred" area of best drainage. Maintain at least a 1/2" clearance from the embossed area.
2. Using the mounting plate with the 1/2" hole as a template, mark and drill two, 3/16" mounting holes and a 1/2" drain hole in the sleeve bottom.

3. Remove the backing from the gasket and mount it on the flat side of the mounting plate (See Figure 12, Page 11). Insert the drain tube through the hole in the gasket and mounting plate so the tube flange will be against the wall sleeve.
4. Position the assembly beneath the drilled holes and secure it with #10-24 x 1/2" machine screws and lock nuts provided. Seal the tops of the screws with silicone caulking.
5. Use 1/2" I D copper tube, PVC pipe, or vinyl hose (obtained locally) to connect the internal drain tube to the drain system in the building.
6. Referring to Figure 12, Detail A, Page 11, locate and assemble the two cover plates and gaskets over the drain holes at the rear of the wall sleeve. Attach them with the #10 sheet metal screws provided. Make certain that the four overflow slots at the rear of the wall sleeve are not blocked (See drawing of the back of the sleeve Figure 12, Page 11).
7. If a deep wall extension (PDXWSEXT) is used, after installing the field supplied flashing, caulk as required. Be sure to caulk around the flashing and the wall sleeve where the hole was drilled for the drain tube.

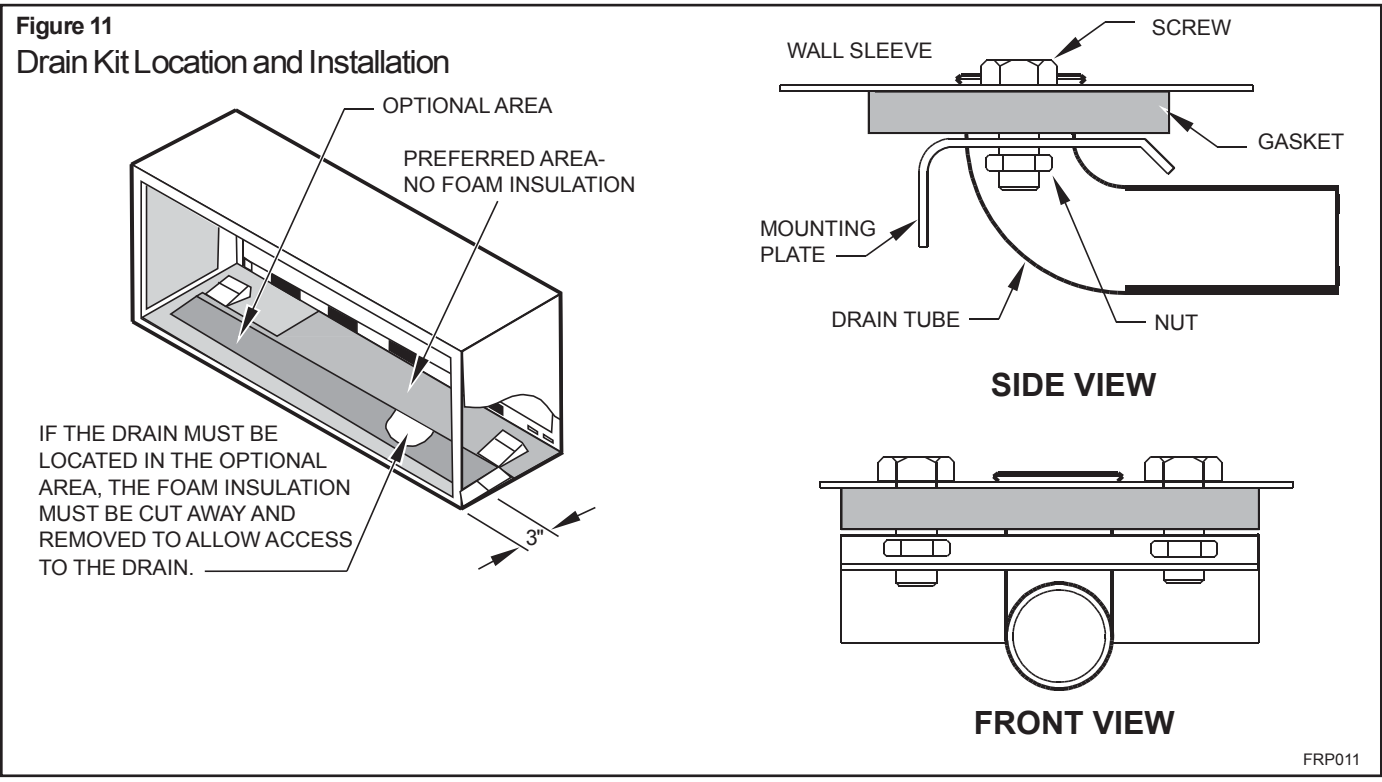

PXDR10	
QUANTITY	DESCRIPTION
2	COVER PLATES
1	MOUNTING PLATE
1	DRAIN TUBE
3	MOUNTING PLATE GASKET
4	#10 X 1/2" SHEET METAL SCREWS
2	#10-24 X 1/2" MACH. SCREWS
2	#10-24 X 1/2" LOCKNUTS



External Drain (for new construction or unit replacement)

When using an external drain system, the condensate is removed through either of two drain holes on the back of the wall sleeve. Select the drain hole which best meets your drainage situation and install the drain kit. Seal off the other with a cover plate.

Drain Tube Installation (See Figure 12)

1. Peel the backing tape off the gaskets and apply the sticky side to one cover plate and one mounting plate as shown in Details A and B.
2. Place the drain tube through the gasket and the mounting plate with the flange toward the wall sleeve.
3. Attach the drain tube assembly to one of the two drain holes at the rear of the wall sleeve. The large flange on the mounting plate is positioned at the bottom of the sleeve facing toward the sleeve, Detail B. When the drain tube is positioned at the desired angle, tighten the screws.

Cover Plate Installation

4. Mount the foam gasket to the cover plate. Using two #10 x 1/2" sheet metal screws (provided), attach the cover plate to the remaining drain hole. Make certain the large flange on the plate is positioned at the bottom of the sleeve.
5. Discard the additional cover plate, gasket, machine screws, and locknuts.

NOTICE

If the wall sleeve has not been installed, the drain tube must be rotated to a horizontal position until after the sleeve is installed. Tighten the mounting plate screws when the tube is in the proper position. Make certain that the four overflow slots at the rear of the wall sleeve are not blocked (See Figure 12).

When sealing the sleeve on the outside of the building, be careful NOT to let the sealant block the two condensate drain holes or the four overflow slots at the bottom flange of the sleeve.

Potential property damage can occur if instructions are not followed.

Figure 12
Drain Kit Installation

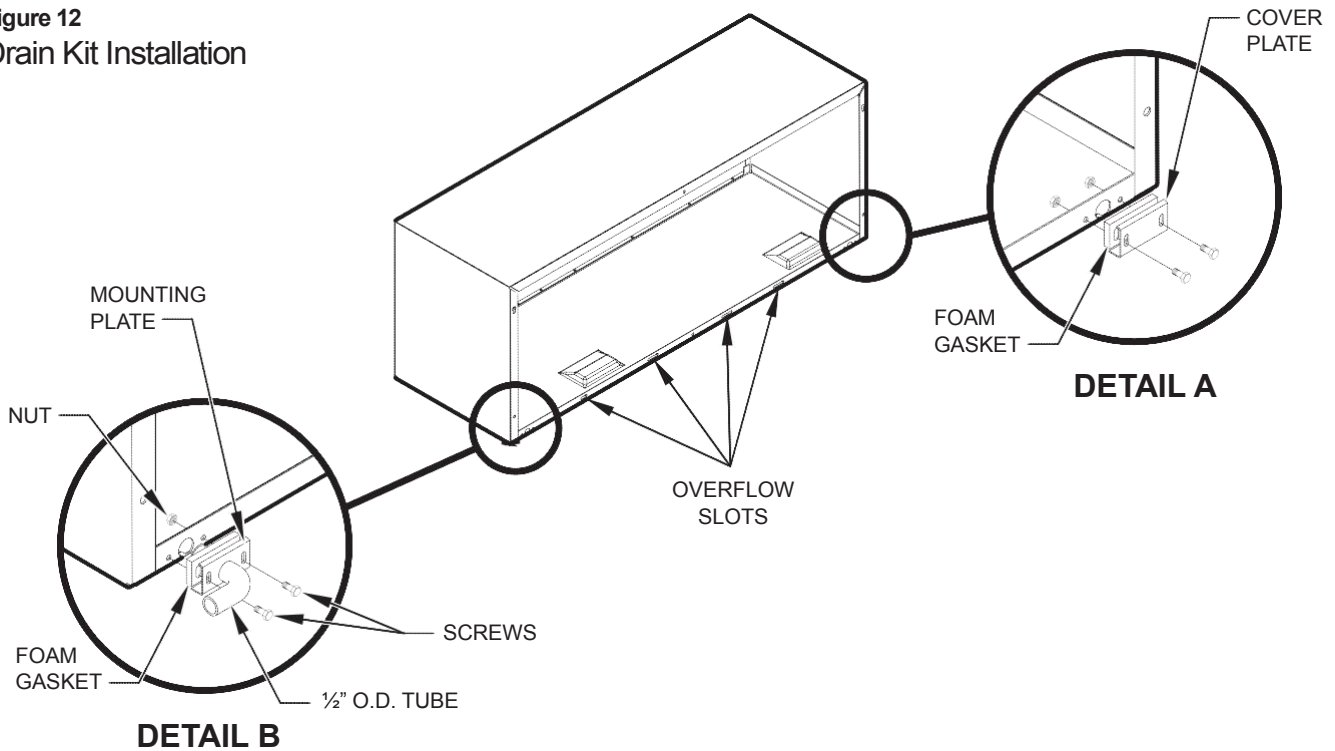

FRP012

NOTE: The large flange on the mounting plate is positioned at the bottom of the sleeve facing toward the sleeve. The drain tube must be rotated to a horizontal position to allow for the wall sleeve to be installed into the wall. Once the wall sleeve is installed, return the drain tube to a downward angle.

PXGA Standard Grille Installation Instructions

1. Remove the center support and weatherboard if still installed in the sleeve.
2. Insert six plastic grommets into the grille openings from the outside of the grille as shown in Figure 13.
3. Insert two #8 x 3/8" sheet metal screws (provided) in the top two outside edge plastic grommets, and tighten them half way into the grommets.
4. Grasp the grille by the attached plastic handles. Position it with the condensate drain knockouts facing down.

From inside the building, maneuver the grille through the wall sleeve and pull toward you until the screw heads are inserted into the keyhole slots at the top of the wall sleeve. Tighten the two screws completely.

5. Insert the remaining screws into the remaining holes and tighten securely.

⚠ WARNING



Falling Object Hazard

Not following Installation Instructions for mounting your air conditioner can result in property damage, injury, or death.

Figure 13
Standard Grille

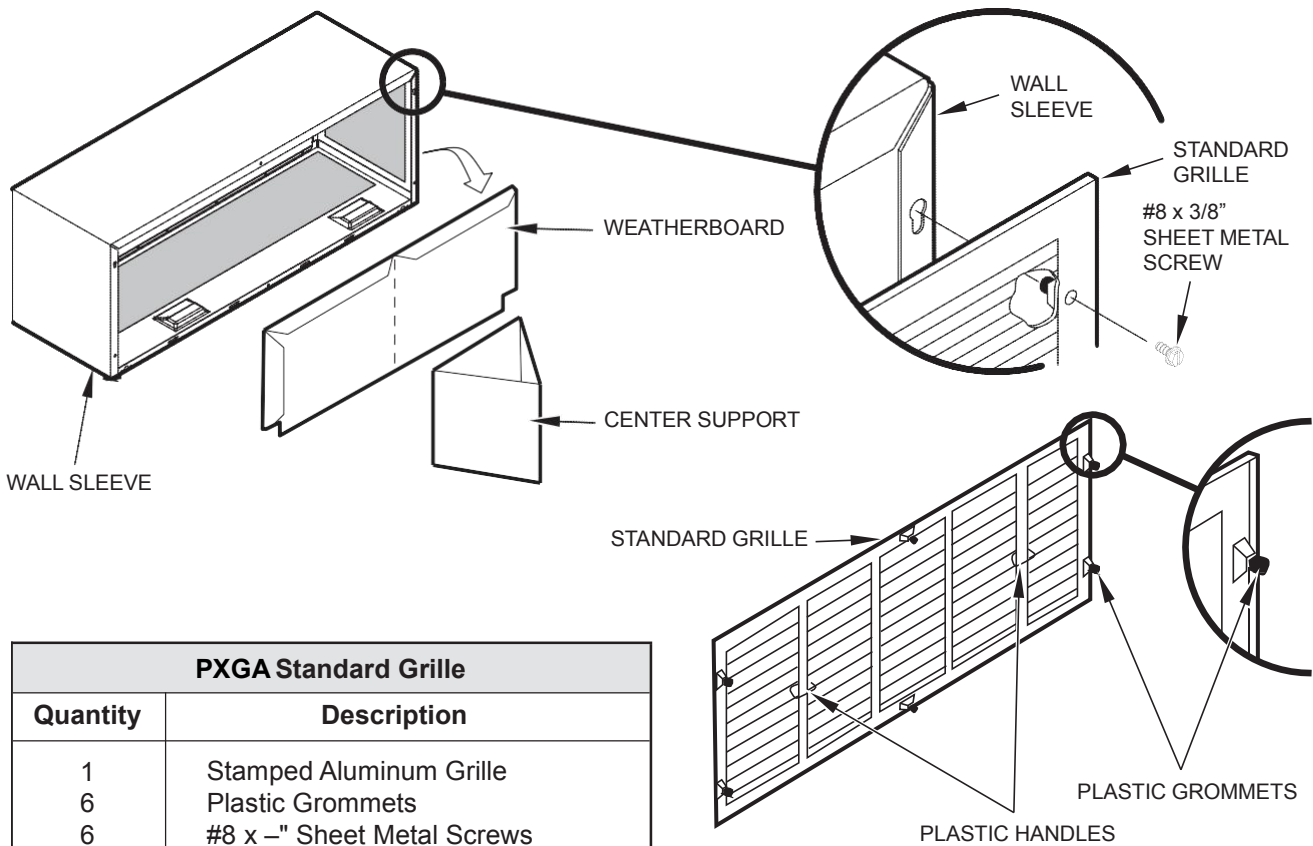

PXGA Standard Grille	
Quantity	Description
1	Stamped Aluminum Grille
6	Plastic Grommets
6	#8 x -" Sheet Metal Screws

FRP013



A. Electrical Rating Tables

All units are equipped with standard power cords.

NOTE: 1.5kW heater only for 12K Btu unit and 2.5kW heater only for 9K Btu unit.

Voltage	230V			265V		
	15	20	30	15	20	30
Amps	15	20	30	15	20	30
Heater Size	1.5/2.5kw	3.5kw	5kw	1.5/2.5kw	3.5kw	5kw
Receptacles						
NEMA# Receptacle	6-15R	6-20R	6-30R	7-15R	7-20R	7-30R
NEMA# Plug	6-15P	6-20P	6-30P	7-15P	7-20P	7-30P

⚠ WARNING

Electrical Shock Hazard

Turn off electrical power before service or installation.

ALL electrical connections and wiring **MUST** be installed by a qualified electrician and conform to the National Code and all local codes which have jurisdiction.

Failure to do so can result in property damage, personal injury and/or death.

FUSE/CIRCUIT BREAKER	Use ONLY type and size fuse or HACR circuit breaker indicated on unit's rating plate. Proper current protection to the unit is the responsibility of the owner. NOTE: A time delay fuse is provided with 265V units.
GROUNDING	Unit MUST be grounded from branch circuit through service cord to unit, or through separate ground wire provided on permanently connected units. Be sure that branch circuit or general purpose outlet is grounded. The field supplied outlet must match plug on service cord and be within reach of service cord. Refer to Table 1 for proper receptacle and fuse type. Do NOT alter the service cord or plug. Do NOT use an extension cord.
RECEPTACLE	The field supplied outlet must match plug on service cord and be within reach of service cord. Refer to Table 1 for proper receptacle and fuse type. Do NOT alter the service cord or plug. Do NOT use an extension cord.

B. Power Cord Information (230/208V models only)

All Friedrich 230/208V PTAC units are shipped from the factory with a Leakage Current Detection Interrupter (LCDI) equipped power cord. The LCDI device meets the UL and NEC requirements for cord connected air conditioners effective August 2004.

To test your power supply cord:

1. Plug power supply cord into a grounded 3 prong outlet.
2. Press RESET.
3. Press TEST (listen for click; Reset button trips and pops out).
4. Press and release RESET (listen for click; Reset button latches and remains in). The power supply cord is ready for operation.

NOTE: The LCDI device is not intended to be used as a switch. Once plugged in the unit will operate normally without the need to reset the LCDI device.

If the LCDI device fails to trip when tested or if the power supply cord is damaged it must be replaced with a new supply cord obtained from the product manufacturer, and must not be repaired.

Figure 14
Typical LCDI Devices

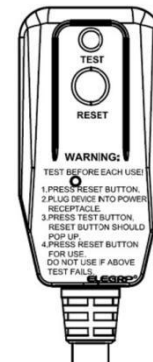

15/20/30A LCDI Device

FRP014



TABLE 2					
MODEL	HEATER kW	Power Cord Kit	Voltage	Amperage	Receptacle
PVH09K	2.5(optional)	STD	230/208	15	NEMA 6-15r
	3.5(default)	STD	230/208	20	NEMA 6-20r
PVH12K	1.5(optional)	STD	230/208	15	NEMA 6-15r
	3.5(default)	STD	230/208	20	NEMA 6-20r
	5.0(optional)	STD	230/208	30	NEMA 6-30r
PVH09R	2.5(optional)	STD	265/277	15	NEMA 7-15r
	3.5(default)	STD	265/277	20	NEMA 7-20r
PVH12R	1.5(optional)	STD	265/277	15	NEMA 7-15r
	3.5(default)	STD	265/277	20	NEMA 7-20r
	5.0(optional)	STD	265/277	30	NEMA 7-30r

Electrical Wiring for 265 Volt Models

Power Cord Installation

All 265V PTAC/PTHP units come with a factory installed non-LCDI power cord for use in a subbase. If the unit is to be hard-wired refer to the instructions below.

NOTE: It is recommended that the PXSBB subbase assembly, the PXCJA conduit kit (or equivalent) be installed on all hardwire units. If installing a flush-floor mounted unit, make sure the chassis can be removed from the sleeve for service and maintenance.

To install the line voltage power leads and conduit to chassis, follow the instructions below. PXCJA Conduit Kit is required with this setup.

1. Follow the removal process of the chassis's junction box.
2. Prepare the 265V (or 230V) power cord for connection to the chassis' power cord connector by cutting the cord to the appropriate length (refer to Figure 16 and follow Figure 15). Power cord harness selection shown on Table 2 on page 14.



 WARNING	
	<p>Electrical Shock Hazard</p> <p>Turn off electrical power before service or installation.</p> <p>ALL electrical connections and wiring MUST be installed by a qualified electrician and conform to the National Code and all local codes which have jurisdiction.</p> <p>Failure to do so can result in property damage, personal injury and/or death.</p>

Figure 15



3. Route the cut ends of harness through the conduit connector assembly and flex conduit sleeve. Be sure to use the supplied conduit bushing to prevent damage to the cord by the conduit. The cord should pass through the Locknut, Spacer, Chassis Junction Box, Conduit Connector, Bushing, then the Conduit Sleeve. See Figure 17.
4. Route the cut ends of the power cord through the elbow connector at the other end of the conduit. Tighten screws on elbow connector to secure conduit sleeve.
5. Fasten and secure the elbow connector to the wall junction box cover with locknut. Place and mount the wall junction box with the four wall mounting screws making sure to pass the wall lines through the junction box. Connect and join all wall lines with the stripped ends using wire nuts. Tighten both screws of the wall junction box cover to junction box.

Figure 16

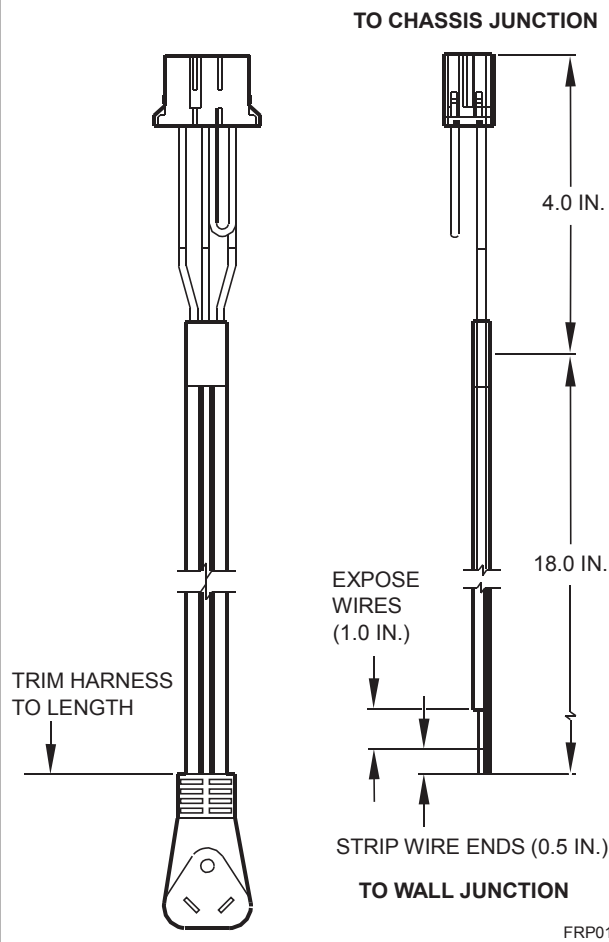
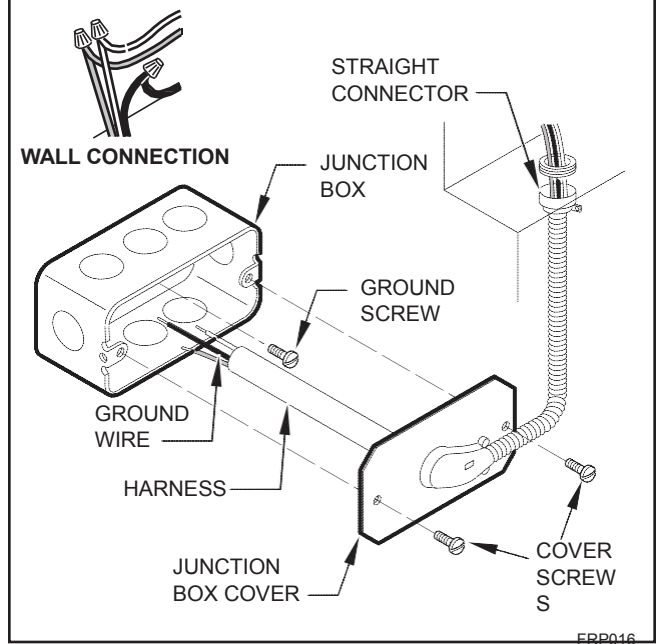
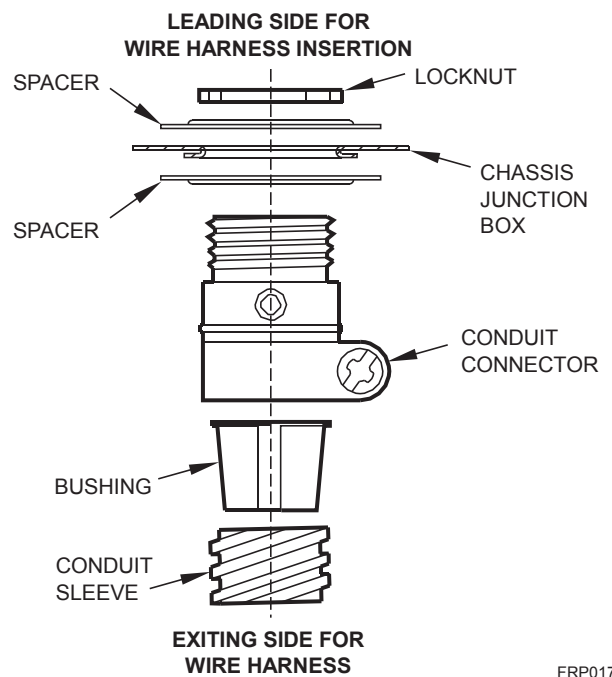

Figure 17



Chassis Install Preparation

Check to be sure the wall sleeve, extension (if used), grille, and drain kit are installed properly before chassis installation.

1. Remove the weatherboard and center support from the sleeve (if still in place). Be sure an outdoor grille is attached.

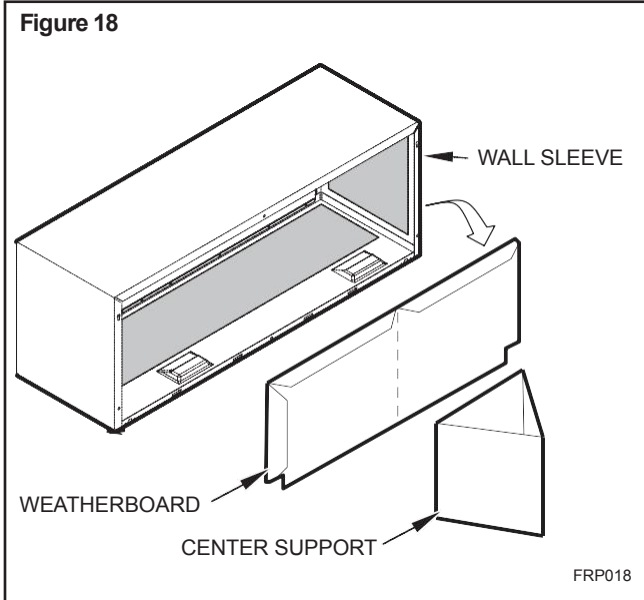

NOTE: Use a wall sleeve adapter kit (PXSE) if installing a P-Series chassis in a T-Series sleeve.

NOTE: To avoid breaking the door or hinge pins, do not apply excessive force when installing.

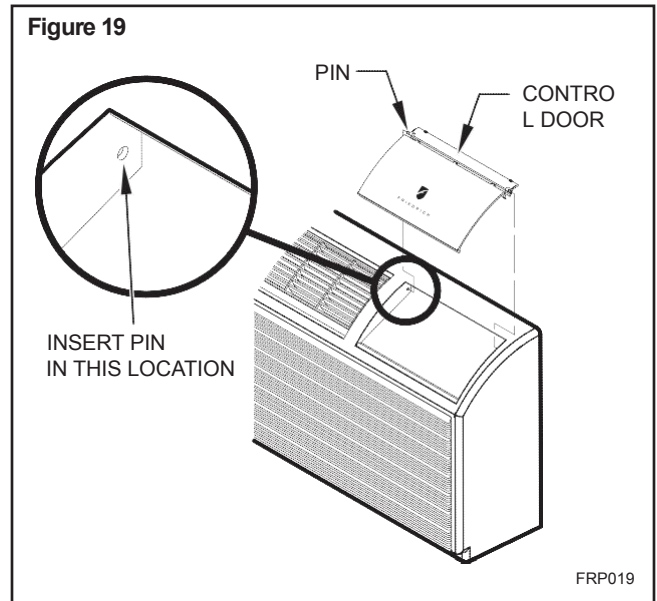

IMPORTANT: When installing a Friedrich PTAC into an existing sleeve, it is important to ensure that the unit is installed completely. Inspection of the air seal between the condenser air baffles and around the indoor mounting flange is recommended.

In some cases additional gaskets or baffling may be required.

 WARNING	
	<p>Suffocation Hazards</p> <p>Keep bag away from babies and children.</p> <p>Do NOT use in cribs, beds or playpens. Destroy immediately after opening. This bag is NOT a toy.</p> <p>Failure to do so can result in personal injury and/or death.</p>

2. Remove the front cover contained in a protective plastic bag from chassis. Remove the bag and dispose of it properly.

If the control door is not installed, follow these steps:

- a. From the front cover, slide the right control door pin into the hole on the right side of the front cover.
- b. Slide the left door pin into the hole on the left side of the front cover opening.
- c. Snap cover into place.

CAUTION

Unit Damage Hazard

Failure to follow this caution may result in equipment damage or improper operation.

3. Carefully remove shipping tape from the front panel and power vent door. See Figure 20.

Figure 20
Shipping Tape Location

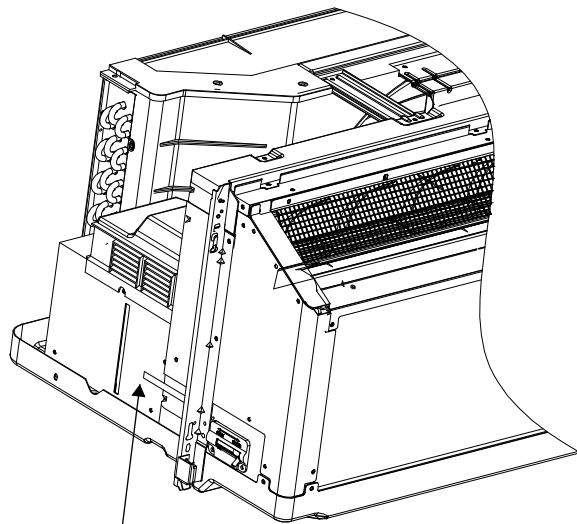

SHIPPING TAPE

FRP020

Figure 21
Removing Front Panel

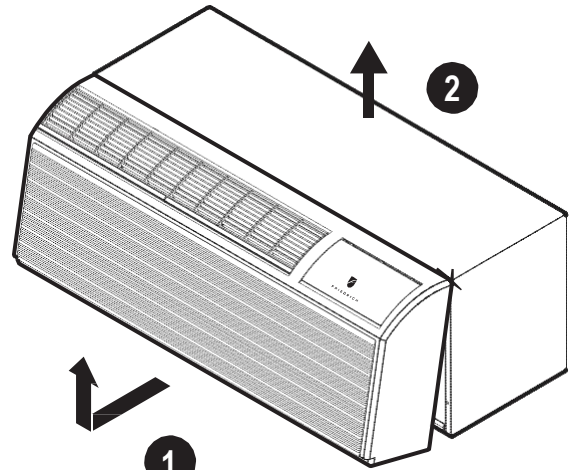

FRP021

4. Remove front panel, see Figure 21.

Pull out at the bottom to release it from the tabs (1). Then lift up (2).

NOTE: If the unit is mounted flush to the floor, the service cord **MUST** be rerouted at the bottom of the front cover on the side closest to the receptacle. A notch **MUST** be made in the front cover side where the cord exits the unit. It is the responsibility of the installer to create an exit notch.

Chassis Installation

1. Lift unit level and slide unit into wall sleeve until seal rests firmly against front of wall sleeve.

Figure 22
Securing Unit

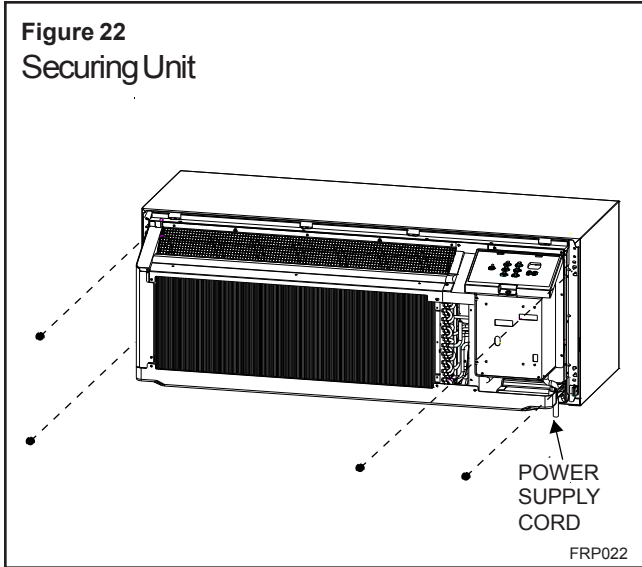

2. Locate the four supplied chassis mounting screws. Insert the screws through the chassis mounting flange holes that are aligned with the speed nuts in the wall sleeve. Tighten all four screws (two per side).

Figure 23
Replacing Front Panel

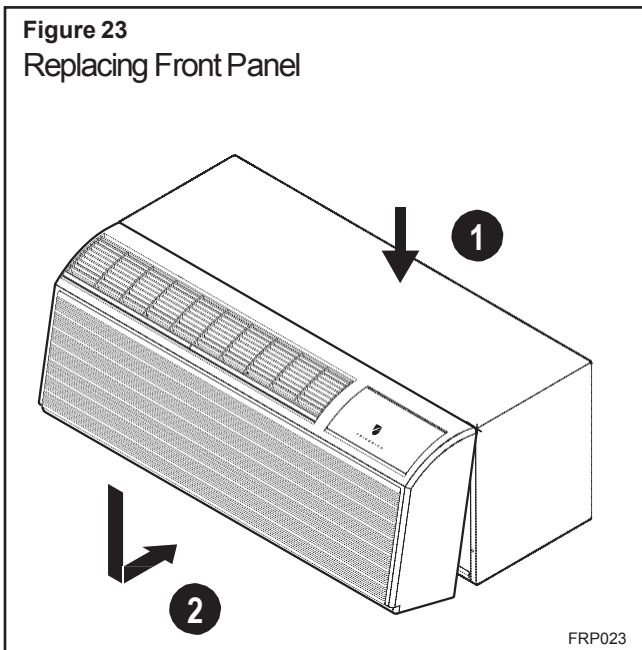

3. Place tabs over top rail. (1) Push inward at bottom until panel snaps into place (2).
4. Reinstall front panel. See Figure 23.

CAUTION



Excessive Weight Hazard

Use two or more people when installing your air conditioner.

Failure to do so can result in back or other injury.

NOTICE

Copper refrigerant tubes are NOT handles.
Do NOT use tubing to lift or move chassis.

To remove the front cover, pull the bottom end forward and lift it up to clear the L bracket across the top of the chassis.

5. Plug the cord (if applicable) into the appropriate receptacle. Restore power to the unit.

Friedrich PTAC Digital Control and Unit Features

The new Friedrich digital PTAC has state of the art features to improve guest comfort, indoor air quality and conserve energy. Through the use of specifically designed control software for the PTAC industry Friedrich has accomplished what other Manufacturer's have only attempted – a quiet, dependable, affordable and easy to use PTAC. Below is a list of features and their benefit to the owner.

ONLY TWO MODELS	With only two models in both 230/208V and two in 265V ranging from 5,800btu– 15,500btu, the FreshAire PTAC meets your needs without the complicated buying decisions.
BETTER DEHUMIDIIFICATION	With longer run times, the indoor coil stays colder longer resulting in better overall dehumidification outside of standard conditions.
SOFT START OPERATION	With the benefit of an inverter compressor there is no longer a sudden and noisy start up of compressors. Compressor starts up slowly gradually ramping up to the required speed to control the conditioned space.
MERV 8 OUTDOOR AIR FILTER	The FreshAire® PTAC meets ASHRAE 62.1 for conditioned air intake, providing up to 52 CFM of conditioned air into the space. Air is filtered through a Merv 8 replaceable filter to prevent debris from entering the air stream.
DC INVERTER	FreshAire PTACs utilize a DC inverter rotary compressor to ensure part load efficiencies and reliable operation.
REMOTE THERMOSTAT OPERATION	Some applications require the use of a wall-mounted thermostat. All new Friedrich PTACs may be switched from unit control to remote thermostat control easily without the need to order a special model or accessory kit.
INTERNAL DIAGNOSTIC PROGRAM	The Friedrich digital PTAC features a self-diagnostic program that can alert maintenance to component failures or operating problems. The internal diagnostic program saves properties valuable time when diagnosing running problems.
ELECTRONIC TEMPERATURE LIMITING	By limiting the operating range, the property can save energy by eliminating “max cool” or “max heat” situations common with older uncontrolled systems. The new electronic control allows owners to set operating ranges for both heating and cooling independently of one another.
ROOM FREEZE PROTECTION	When the PTAC senses that the indoor room temperature has fallen to 50°F, the unit will cycle on the fan (high) and the electric strip heat to raise the room temperature to 55°F, and then cycle off again. This feature works regardless of the mode selected and can be turned off.
CONDENSATE REMOVAL SYSTEM	Condenser fan utilizes slinger ring technology to pick up condensate from the base pan and disperse it on to the condenser coil where it evaporates. This helps to cool the coil and increase the energy efficiency of the unit.
UNIVERSAL ELECTRIC HEATER	Unit has a universal power cord with 20 Amp coming standard out of the box.
FACTORY RUN-TEST	All units are factory run tested to ensure trouble free operation.



DIGITAL DEFROST THERMOSTAT	The PV-Series uses a digital thermostat to accurately monitor the outdoor coil conditions to allow the heat pump to run whenever conditions are correct. Running the PTAC in heat pump mode saves energy and reduces operating costs. The digital thermostat allows maximization of heat pump run time.
INSTANT HEAT HEAT PUMP MODE	Heat pump models will automatically run the electric heater to quickly bring the room up to temperature when initially energized, then return to heat pump mode. This ensures that the room is brought up to temperature quickly without the usual delay associated with heat pump units.
SEPARATE HEAT/COOL FAN CYCLE CONTROL	The owner may choose between fan cycling or fan continuous mode based on property preference. Fan continuous mode is used to keep constant airflow circulation in the room during all times the unit is 'ON'. Fan cycle will conserve energy by only operating the fan while the compressor or electric heater is operating. The ability to set the fan cycling condition independently between heating and cooling mode will increase user comfort by allowing the choice of only constantly circulating air in the summer or winter time (unlike other PTAC brands that only allow one selection).
EMERGENCY HEAT OVERRIDE	In the event of a compressor failure in heat pump mode, the compressor may be locked out to provide heat through the resistance heater. This feature ensures that even in the unlikely event of a compressor failure, the room temperature can be maintained until the compressor can be serviced.
CENTRAL DESK CONTROL READY(ONLY FOR UNIT CONTROL)	All Friedrich digital PTACs have low voltage terminals ready to connect a central desk control energy management system. Controlling the unit from a remote location like the front desk can reduce energy usage and requires no additional accessories on the PTAC unit.
INDOOR COIL FROST SENSOR	The frost sensor protects the compressor from damage in the event that airflow is reduced or low outdoor temperatures cause the indoor coil to freeze. When the indoor coil reaches 33°F, the compressor is disabled and the fan continues to operate based on demand. Once the coil temperature returns to 53°F, the compressor returns to operation.
ULTRAQUIET AIR SYSTEM	The PV-Series units feature an indoor fan system design that reduces sound levels without lowering airflow or preventing proper air circulation.
HIGH EFFICIENCY	The Friedrich PTAC has been engineered so that all functional systems are optimized so that they work together to deliver the highest possible performance.
DUAL MOTOR	The dual-motor design means that the indoor motor can run at slower speeds which reduces sound levels indoors.
ROTARY COMPRESSOR	High efficiency rotary compressors are used on all Friedrich PTACs to maximize durability and efficiency.
TOP-MOUNTED AIR FILTERS	All Friedrich PTAC return air filters and PXFTB replacement filter kits are washable, reusable and easily accessed from the top of the unit without the removal of the front cover.
FILTERED FRESH AIR INTAKE	Friedrich PTAC units are capable of introducing up to 52 CFM of outside air into the conditioned space. The outdoor air passes through a washable mesh screen to prevent debris from entering the airstream.
ALUMINIUM ENDPLATES	Outdoor coil endplates made from aluminium reduce corrosion on the outdoor coil common with other coil designs.
R-32 REFRIGERANT	Friedrich PTAC units use environmentally-friendly refrigerant.
BREAK-PROOF CONTROL DOOR	Break-proof control door design maintains the integrity of the unit.
GALVANIZED ZINC WALL SLEEVE AND BASE PAN	Galvanized zinc coated steel wall sleeve and steel base pan undergo an 11-step preparation process, are powder coated with a polyester finish and cured in an oven for exceptional durability.

System Configuration

Fresh Air Vent Control

To operate the FreshAire module please see Dip switch #3 (SW3) and Dip switch #4 (SW4). With dip switch in the "on" position FreshAire module will be on continuously. With dip switch in the "OFF" position FreshAire module will be not be activated.

Figure 25
Air Vent Control

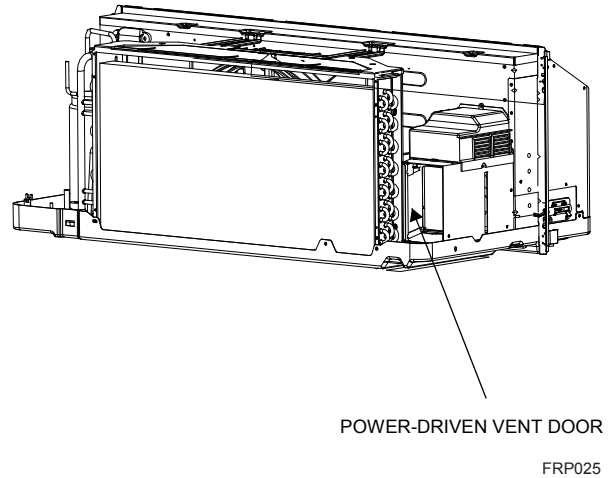

Adjusting Air

To adjust air direction:

1. Remove front panel. See Figure 21.
2. Remove louver screws that hold louver insert in place (from back side of front panel). See Figure 29.
3. Turn louver insert and rotate 180°. See Figure 30.
4. Replace louver insert.
5. Replace screws and front panel.

Figure 26
Backside of Front Panel

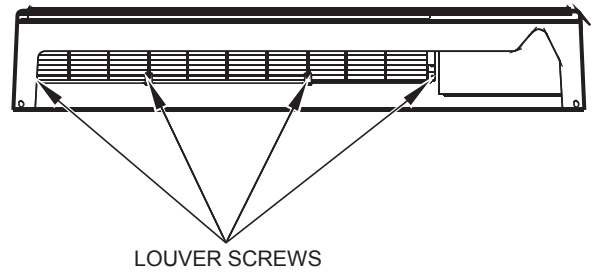
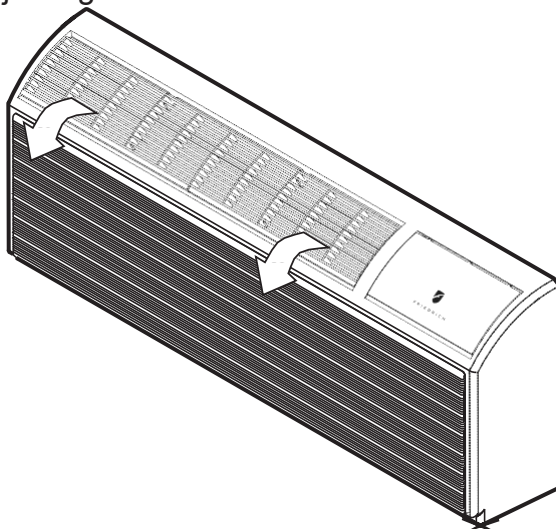
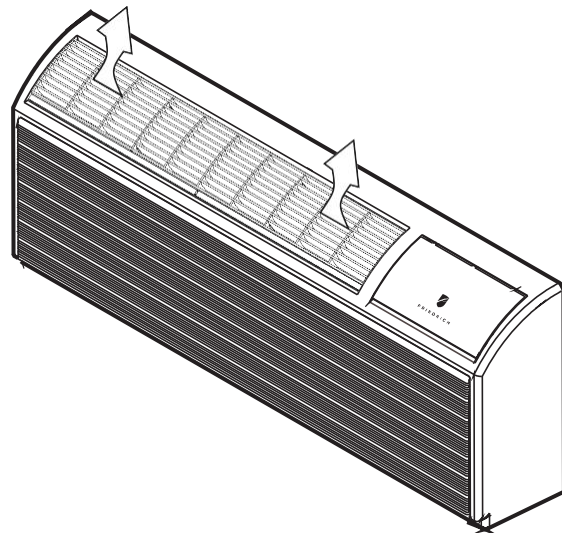

Figure 27
Adjusting Louvers



AIR DISCHARGE OUTWARD (Default)



AIR DISCHARGE UPWARD

FRP027

Digital Control User Input Configuration

The adjustable control dip switches are located at the front portion of the digital Smart Center. The inputs are only visible and accessible with the front cover removed from the PTAC.

Dip Switch Setting

Switch 1-Reserved.

Switch 2-Heat pump enable/disable.

Moving Dip Switch #2 to "OFF" can be set as Emergency Heat Override. In the unlikely event of a compressor failure, a heat pump unit may be switched to operate in only the electric heat mode until repairs can be made.

Switch 3-Electric strip enable/disable.

Switch 4-Reserved.

Switch 5-Room Freeze Protection Units are shipped from the factory

With the room freeze protection enable. Room Freeze Protection can be switched off at the owner's preference by moving Dip Switch 5 to "OFF". This feature will monitor the indoor room conditions and in the event that the room falls below 50°F, the unit will automatically run "heating". This occurs regardless of mode.

Switch 6-Electric memory enable/disable

The factory setting is enabled. The smart center will remember user's setting. After power cut recovery, the unit will operate the same status as before power cut. Moving Dip Switch 6 to "OFF" will disable this feature, smart center will no more remember settings.

Switch 7, Switch 8-Reserved.

Figure 28
Dip Switches

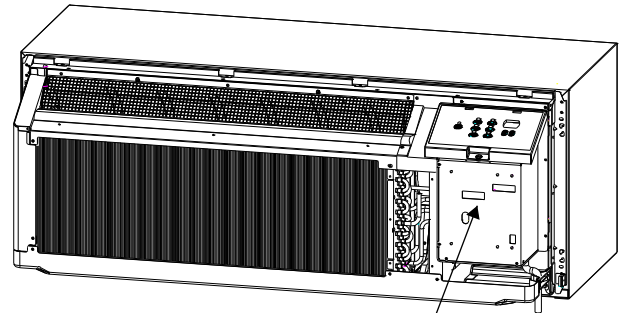
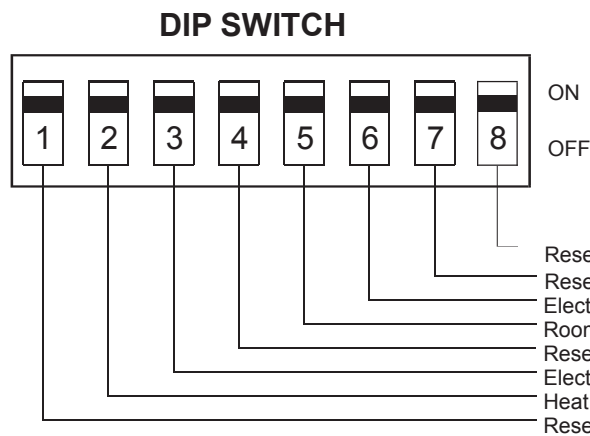

LOCATION OF
DIP SWITCHES
ON UNIT

FRP028

Switch	Description	Function	Factory setting	Option
#1	Reserved	/	OFF	/
#2	Heat pump	ON-enable heat pump; OFF-disable heat pump, run electric heat only.	HP models-ON Electric heat only-OFF	OFF-Overrides compressor operation(HP models only)
#3	Electric strip	ON-enable electric heat; OFF-disable electric heat.	ON	Factory set. Do not change.
#4	Reserved	/	OFF	/
#5	Room Freeze Protection	ON-Allows the unit to ensure the indoor room temperature does not fall below 50°F even when turned off; OFF-disable freeze protection.	ON	OFF
#6	Electric memory enable/disable	ON-enable; OFF-disable.	ON	OFF
#7	Reserved	/	OFF	/
#8	Reserved	/	OFF	/



**FreshAir System
SW3 DIP SWITCH**

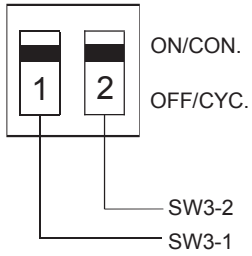

	Engagement Method	Mode	Description
FreshAir System	SW3-1	ON / OFF	Fresh-Air Fan runs only when Dip Switch is set to 'ON'
			Fresh-Air Fan NEVER RUNS when Dip Switch is set to 'OFF'
FreshAir System	SW3-2	Cycle / Continuous	Fresh-Air Fan runs continuously when SW3-1 is set to 'ON' & SW3-2 is set to 'ON'
			Fresh-Air Fan cycles On/Off with the Unit Indoor Fan when SW3-1 is set to 'ON' & SW3-2 is set to 'OFF'

**FreshAir Fan Speed
SW4 DIP SWITCH**

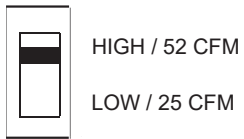

	Engagement Method	Mode	Description
FreshAir Fan Speed	SW4	HIGH / LOW	'HIGH' - When Fresh-Air Fan is operating due to SW3, will intake up to 52 CFM
			'LOW' - When Fresh-Air Fan is operating due to SW3, will intake up to 25 CFM

Digital Control Operation

Figure 29
Digital Control Panel

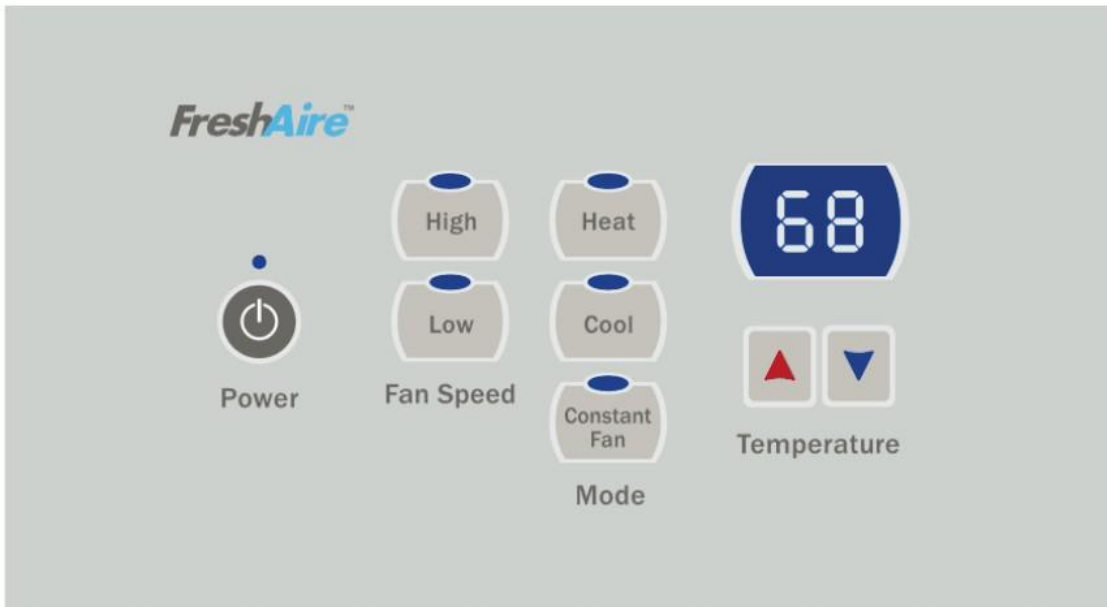

FRP029

Cooling Mode

Pressing the "Cool" button after turn the unit on will put the unit into cooling mode. Press "UP" or "DOWN" button to adjust the set point, the unit will start the compressor and run appropriate frequency to maintain a comfortable room temperature. The compressor will come on anytime that the room temperature is 2°F above the set point. The fan will come on with compressor.

Heating Mode

After turn on the unit, press the "Heat" button will put the unit into heating mode.

Heat Pump Models (PVH)

When the "Heat" button is pressed initially the unit may call for electric strips to bring the room to the set point. When the room temperature falls 2°F below the set point, the unit will turn on the compressor or electric strip. The fan will run with compressor or electric strips. When the outdoor ambient temperature falls below 32°F or outdoor coil temperature drops to 5°F, the unit will operate the electric strip instead of heat pump. During heat pump mode, CPU detects the outdoor coil gets freeze, unit will go to passive defrost. During the passive defrost operation (10min at most), there will be no heating provide. After finishing defrost, electric heating will come on to warm the room quickly.

Emergency Heat Operation

In the event of a compressor failure in heat pump mode, the compressor may be locked out to provide heat through the electric strip heater automatically. This feature ensures that even in the unlikely event of a compressor failure, the room temperature can be maintained until the compressor can be serviced. If the unit still can't run electric heater stably, switch Dip switch 2 to OFF, it controls the emergency heat setting.

Constant Fan

Pressing the "Constant Fan" button will provide constant or cycle fan operation in cooling or heating modes. The fan speed selection is made by pressing either "High" or "Low" fan speed button.

Settings- Detailed Configurations

This section is about how to set the unit operating parameter, include display temperature unit, Fahrenheit or Celsius, control master, temperature limit, temperature calibration, display set point or room temperature.

Under OFF mode, hold [Cool] and [Low] two keys at the same time continuously for 5 seconds. This time displays 'd0', indicates that system has entered the senior operation status.

[Cool] key is used to switch parameter code and parameter value;

[UP] or [DOWN] keys are used to switch parameter code or set parameter value; [Power] key is used to save

and exit settings.

Menu NO.	Function	Parameter value	Explanation
d0	Unit of temperature	F	Fahrenheit(default)
		C	Celsius
d1	Control master	P	By control panel(default)
		r	By 24V universal remote thermostat
		rE	By 12V smart wired controller
		rF	VRPXEMRT2 and VRPXEMWRT2 Energy management Controller
d2	Max temperature setting	d3 to 90 °F	The Min value is d2 (default 90 °F)
d3	Min temperature setting	60 °F to d2	The Max value is d3 (default 90 °F)
d4	Indoor temperature calibration	-9°C to 9°C	If unit of temperature is changed, calibration should be done again. If use the default value, it can be ignored. (default 0°C/0 °F)
		-9°F to 9°F	
d5	Temperature display selection	0 or 1	0-displays room temperature 1-displays set point(default)

One example:

Setting target:d0(C),d1(r), d2(88°F),d3(58°F),d4(-1°F),d5(1).

Step1: hold [Cool] and [Low] two keys at the same time continuously for 5 seconds. Display:'d0'

Step2: short press [Cool] key. Display: 'F'(setting d0 has finished)

Step3: short press [Cool] key. Display:'d0'

Step4: short press [UP] key. Display:'d1'

Step5: short press [Cool] key. Display: 'P'

Step6: short press [UP] or [DOWN] key. Display: 'r' (setting d1 has finished)

Step7: short press [Cool] key. Display:'d1'

Step8: short press [UP] key. Display:'d2'

Step9: short press [Cool] key. Display:'90'

Step10: short press [DOWN] key twice. Display:'88' (setting d2 has finished)

Step11: short press [Cool] key. Display:'d2'

Step12: short press [UP] key. Display:'d3'

Step13: short press [Cool] key. Display:'60'

Step14: short press [UP] key twice. Display:'58' (setting d3 has finished)

Step15: short press [Cool] key. Display:'d3'

Step16: short press [UP] key. Display:'d4'

Step17: short press [Cool] key. Display:'0' (setting d4 has finished)

Step18: short press [Power] key to exit.

Remote Control Thermostat Installation

Install Thermostat

1. Approximately 5 ft from the floor.
2. Close to or in a frequently used room, preferably on an inside wall.
3. On a section of wall without pipes or ductwork.

The Thermostat should NOT be mounted:

1. Close to a window, on an outside wall, or next to a door leading outside.
2. Where it can be exposed to direct sunlight or heat, such as the sun, a lamp, fireplace or any other temperature radiating object which may cause a false reading.
3. Close to or in the direct airflow of supply registers and/or return air grilles.
4. Any areas with poor air circulation, such as a corner, behind a door, or an alcove.

Remote Thermostat and Low Voltage Control Connections

Remote Thermostat

All Friedrich PV model PTAC units are factory configured to be controlled by either the chassis mounted Smart Center or a 24V remote wall mounted thermostat. The thermostat may be auto or manual changeover as long as the control configuration matches that of the PTAC unit.

NOTE: All PV models require a single stage cool, dual stage heat thermostat with an B reversing valve control. The Friedrich RT6 thermostat can be configured for either model.

To control the unit with a wall mounted thermostat follow the steps below:

1. Unplug the unit before doing any work
2. Remove the low voltage terminal block from the unit.
3. Connect the corresponding terminals from the wall thermostat to the terminal block
4. Plug the terminal block on the unit.
5. Restore power to the unit.
6. Under OFF mode, set menu NO.'d1' to "r", details refer to the previous section "Settings- Detailed Configurations" on page 25.
7. The unit is now controlled by the wall thermostat only.
8. If the accessory escutcheon kit (PDXRTA) is to be used, install it over the existing control panel.

NOTE: The unit control panel no longer controls the unit. To restore the control panel, set menu NO.'d1' back to "P", details refer to the previous section "Settings- Detailed Configurations" on page 2

Thermostat Connections

R = 24V Power from Unit

Y = Call for Cooling

W = Call for Heating

B = Reversing Valve Energized in Heating Mode

GL = Call for Low Fan

GH = Call for High Fan

C = Common Ground

*If only one G terminal is present on thermostat connect to GL for low speed fan or to GH for high speed fan operation.

Figure 30
Control board with optional **PDXRTB** escutcheon kit installed

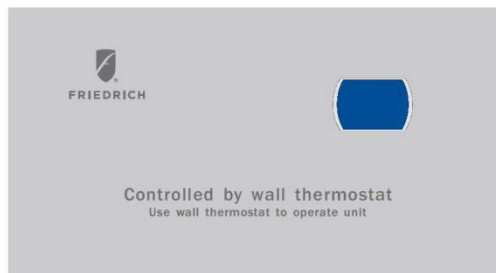

FRP030

Front Desk Control Terminal (ONLY FOR UNIT CONTROL)

The Friedrich PV model PTAC has built-in provisions for connection to an external switch to control power to the unit. The switch can be a central desk control system.

For front desk control operation, connect one side of the normal open switch to the R terminal and the other to the FD terminal.

The control logic as below:

- (a). Turn ON unit: short R and FD then release for one time within 5s.
- (b). Turn OFF unit: short R and FD then release for twice within 5s.
- (c). Force unit shut down for one time: short R and FD short over 5s.



NOTE: After forced shut down, you can turn on the unit again by control panel.

NOTE: The desk control system and switches must be field supplied.

Energy Management

Sometimes known as Front Desk Control, an input is provided so that the unit can be manually disabled from a remote location. If the unit detects 24Vac on this input, it will automatically turn itself off. If no voltage is detected on the input, the unit will run normally.

NOTE: It is the installer's responsibility to ensure that all control wiring connections are made in accordance with the installation instructions. Improper connection of the thermostat control wiring and/or tampering with the unit's internal wiring can void the equipment warranty. Other manufacturer's PTACs and even older Friedrich models may have different control wire connections. Questions concerning proper connections to the unit should be directed to Friedrich.

 WARNING	
	<p>Electrical Shock Hazard</p> <p>Turn off electrical power before service or installation.</p> <p>ALL electrical connections and wiring MUST be installed by a qualified electrician and conform to the National Code and all local codes which have jurisdiction.</p> <p>Improper connection of the thermostat control wiring and/or tampering with the units internal wiring may result in property damage, personal injury or death.</p>

Final Inspection & Start-up Checklist

- ❑ Inspect and ensure that all components and accessories have been installed properly and that they have not been damaged during the installation process.
- ❑ Check the condensate water drain(s) to ensure they are adequate for the removal of condensate water, and that they meet the approval of the end user.
- ❑ Ensure that all installations concerning clearances around the unit have been adhered to. Check to ensure that the unit air filter, indoor coil, and outdoor coil are free from any obstructions.
- ❑ Ensure that the entire installation is in compliance with all applicable national and local codes and ordinances that have jurisdiction.



- ❑ Secure components and accessories, such as the chassis, decorative front cover and control door.
- ❑ Start the unit and check for proper operation of all components in each mode of operation. Instruct the owner or operator of this unit's operation, and the manufacturer's recommended routine maintenance schedule.

NOTE: A log for recording the dates of maintenance and/or service is recommended.

- ❑ Present the owner or operator of the equipment with the Installation & Operation manual, all accessory installation instructions, and the name, address and telephone number of the Authorized Friedrich Warranty Service Company in the area for future reference if necessary.

Routine Maintenance

To ensure proper unit operation and life expectancy the following maintenance procedures should be performed on a regular basis.

 WARNING	
	Electrical Shock Hazard Unplug Unit or turn off electrical power to unit prior to performing maintenance procedures Failure to do so can result in electrical shock or death

Front Panel Air Filter

To ensure proper unit operation, the air filters should be cleaned at least monthly, and more frequently if conditions warrant. The unit must be turned off before the filters are cleaned.

To remove the air filters, filter grasp the top of the filters and lift out of the front cabinet. Reverse the procedure to reinstall the filters.

Clean the filters with a mild detergent in warm water, and allow them to dry thoroughly before reinstalling.

Fresh Air Filter

The fresh air filter should be cleaned or replaced after 3 months of use for maximum effectiveness. The unit must be turned off before the filters are replaced.

To replace the fresh air filters, drag the unit from wall sleeve and pull the tape stuck to fresh air filter.

Coils & Chassis

NOTE: Do not use a caustic coil cleaning agent on coils or base pan. Use a biodegradable cleaning agent and degreaser. The use of harsh cleaning materials may lead to deterioration of the aluminum fins or the coil end plates.

The indoor coil and outdoor coils and base pan should be inspected periodically (annually or semi-annually) and cleaned of all debris (lint, dirt, leaves, paper, etc.) as necessary. Under extreme conditions, more frequent cleaning may be required. Clean the coils and base pan with a soft brush and compressed air or vacuum. A pressure washer may also be used, however, you must be careful not to bend the aluminium fin pack. Use a sweeping up and down motion in the direction of the vertical aluminium fin pack when pressure cleaning coils.

NOTE: It is extremely important to insure that none of the electrical and/or electronic parts of the unit get wet. Be sure to cover all electrical components to protect them from water or spray.

Decorative Front

The decorative front and discharge air grille may be cleaned with a mild soap or detergent. Do NOT use solvents or hydrocarbon based cleaners such as acetone, naphtha, gasoline, benzene, etc., to clean the decorative front or air discharge grilles.

Use a damp (not wet) cloth when cleaning the control area to prevent water from entering the unit, and possibly damaging the electronic control.

Fan Motor & Compressor

The fan motor & compressor are permanently lubricated, and require no additional lubrication.

Wall Sleeve

Inspect the inside of the wall sleeve and drain system periodically (annually or semi-annually) and clean as required.

Under extreme conditions, more frequent cleaning may be necessary. Clean both of these areas with an antibacterial and antifungal cleaner. Rinse both items thoroughly with water and ensure that the drain outlets are operating correctly. Check the sealant around the sleeve and reseal areas as needed.

Basic Troubleshooting

Malfunction	Possible Reasons	Solution
Start Failure	power line bad, units don't have power supply.	Check the indicator LED on the LCID power head, it should be lit up, if not, push the RESET button, if still don't have voltage, but power grid has output, you need to change the power cord.
	Power cord protection trip.	Check the power cord if somewhere is broken, push the RESET button. If not solved, replace the power cord.
	Power cord isn't fixed well.	Check that whether power cord is fixed well.
	PCB fuse is broken.	Check if any load (in fan, out fan, reversing valve, power transformer) is short circuit. Eliminate the error and replace the fuse with the same type.
	Bad contact between main board and control panel.	Check the contact wires, make sure all contact well.
	Compressor delay start.	It's normal, compressor will start after 3 minutes
	Power fail protection.	When power on, because of auto-restart, unit will delay starting in 120~240s
	Unit in protection mode.	Please check the ERROR CODE
	Main board or Control panel is bad.	Replace the main board or control panel
Control panel do not work	When the unit is switch to 24V remote thermostat or 12V smart controller, the control panel will not be functioning.	If you need to use control panel to take control, you need to switch the control master. See the SENIOR SETTINGS section.
Indoor fan/outdoor fan not function or run slowly	Fan is locked by something or the power wires are not fixed well; fan capacitor is not fixed well; fan capacitor is out of service life.	Disconnect the power cord, check whether the fan can run smooth by hand or other tools, whether motor wire is fixed well. For the slow running speed, you could change a new capacitor.
Not cooling/heating adequately	Something may block the indoor/outdoor air outlet.	Make sure that there is no obstacle at the indoor/outdoor air outlet.
		Make sure that the grill is suitable for the unit, inappropriate grill will cause the compressor being protected; make sure that the grill has more than 70% turn over.
	Set unsuitable temperature.	Set higher/lower temperature by the control board. NOTE: temperature setting restriction will restrict the setting temperature. See the SENIOR SETTINGS section.
	Indoor air filter is dirty.	Should clean the filter every month at least.
	Room is hot/cold.	Let unit run a little longer that room temperature will be lower/higher.
	Heat leakage between indoor and outdoor.	Block the leakage place.
	Indoor coil not cold/heat.	Charge the refrigerant.
Unit has noise	Some moving parts of the unit get loose fixing or cause bad vibration. Something in the air way.	Make sure that all moving parts are assembled well, and nothing is in the air way.
Bad smell when heating	The dust on the E-heater is heating.	The bad smell will disappear a little later.



Malfunction	Possible Reasons	Solution
Outlet temperature is not always cooling/heating	Outlet temperature is not high enough when heating by heat pump.	When outdoor ambient temp is low, the heat pump will not be able to offer enough heat. Soon after that, the E-heater will come on to heat.
	Fan stops when cooling/heating.	It is normal when the CONSTANT FAN is OFF. You can enable the CONSTANT FAN.
Outdoor is dripping water	Not install the drain pipe kit.	Install the drain pipe kit.
Indoor is dripping water	Wall sleeve is not installed correctly.	Install the wall sleeve according to the installation manual.
Indoor coil freeze	Outdoor temperature is too low in cooling mode.	When outdoor temperature is drop to 55°F (12.8°C) or below, it will cause that indoor coil freeze. Open the fresh air door, and running at fan mode.
	Filter is dirty.	Clean the filter to recover the normal air flow

Error code and solutions

ERROR CODE	Meaning	Solutions
E1	Communication failure between indoor unit and outdoor unit	Check the communication cables; make sure they are firmly connected. If the cables are broken, replace them.
E2	Indoor Temp Sensor Open/short	Check the plug is firmly connected. If the sensor is broken, replace it.
E3	Indoor Coil Sensor Open/short	Check the plug is firmly connected. If the sensor is broken, replace it.
E4	1. Indoor Air Outlet Sensor Open/Short 2. Outlet Air Over Heat In Electric Heating Mode	1. Check the plug is firmly connected. If the sensor is broken, replace it. 2. In E-Heating mode, check if any obstacles around the air path, remove them. Make sure the air flow is not blocked.
E5	IPM(DC-INVERTER) Protection (Include Heat sink Over Heat)	1. Check the wiring of compressor to the IPM (U/V/W) terminals is correctly connected. Wrong phase connection is not allowed. 2. Remove obstacles in the air path that resists heat interchange.
E6	Outdoor Temp Sensor Open/Short	Check the plug is firmly connected. If the sensor is broken, replace it.
E7	Outdoor Coil Sensor Open/Short	Check the plug is firmly connected. If the sensor is broken, replace it.
EC	Compressor Fail Starting/DC-Inverter Fail	1. Check the DIP switch SW2 on the main board (3-position, in red color) is correctly matched with the unit capacity, refer to the wiring diagram. Make sure the compressor power cord is firmly and correctly connected.
EH	EEPROM Error	Check the EEPROM chip on the main board is firmly plugged. If still not solve, replace the main board.
EF	Power Cord Error For 9KBTU, 30A Is NOT Allowed	Change the power cord to 15A or 20A.
P1	Cooling/Heat Pump Over Load, Outdoor/Indoor Coil Over Heat	Make sure indoor and outdoor unit vents are not blocked. Clear the air filter and the condenser after a long time use.
P2	IPM Over Heat Or Over Current Protection	1. Make sure indoor and outdoor unit vents are not blocked. 2. Check the DIP switch SW2 on the main board (3-position, in red color) is correctly match with the unit capacity, refer to the wiring diagram. 3. Make sure the compressor power cord is firmly and correctly connected.
P4	Compressor Discharge Over Heat Protection	1. Make sure indoor and outdoor unit vents are not blocked. 2. Check the DIP switch SW2 on the main board (3-position, in red color) is correctly match with the unit capacity, refer to the wiring diagram.
P7	DC Over/Under Voltage Protection	Make sure the power supply is within the requirement (AC208/230V - 10%+10%)

Service & Assistance

Before calling for service, please check the "Basic Troubleshooting" section above. This may help you to find the answer to your problem, avoid unnecessary service calls, and save you the cost of a service call if the problem is not due to the product itself. If you have checked the "Basic Troubleshooting" section and still need help, here is a list of available services:

You can find the name of your local Authorized Service Provider by visiting our web site at www.friedrich.com.









If you require further assistance you can call the Customer Support Call Center at 1-800-541-6645.

Before calling, please make sure that you have the complete model and serial number, and date of purchase of your equipment available. By providing us with this information we will be better able to assist you.

Our specialists are able to assist you with:





- * Inspect and ensure that all components and accessories have been installed properly and that they have not been damaged during the installation.
- * Specifications and Features of our equipment.
- * Referrals to dealers, and distributors.
- * Use and Care information.
- * Recommended maintenance procedures.
- * Installation information.
- * Referrals to Authorized Service Providers and Parts depots.

ACCESSORIES

New Construction Accessories		
<p>PDXWSA</p> <p>PDXWSEXT18</p> <p>PDXWSEXT24</p> <p>PDXWSEXT</p>	<p>WALL SLEEVE Galvanized zinc coated steel is prepared in an 11-step process, then powder coated with a polyester finish and cured in an oven for exceptional durability. The wall sleeve is insulated for sound absorption and thermal efficiency, 16" H x 42" W x 13³/₄" D.</p> <p>DEEP WALL SLEEVE For walls up to 17¹/₂" deep.</p> <p>DEEP WALL SLEEVE For walls up to 23¹/₂" deep.</p> <p>CUSTOM DEEP WALL SLEEVE One piece extended wall sleeve for walls from 13¹/₄" to 25¹/₂" deep are available by special order.</p>	<p>PDXWSA</p>   <p>Deep wall sleeve PDXWSEXT18 shown with weather panel</p>
<p>PXGA</p>	<p>GRILLE Standard, stamped aluminium, anodized to resist chalking and oxidation.</p>	
<p>PXAA</p> <p>PXBG</p> <p>PXSC</p>	<p>ARCHITECTURAL GRILLES Consist of heavy-gauge 6063-T5 aluminum alloy: 42" W x 16" H x 1¹/₈" D</p> <p>PXAA – Clear, extruded aluminum PXBG – Beige acrylic enamel PXSC – Also available in custom colors.</p>	<p>PXGA</p>  <p>PXAA</p>
<p>PXDR10</p>	<p>CONDENSATE DRAIN KIT Attaches to the bottom of the wall sleeve for internal draining of condensate or to the rear wall sleeve flange for external draining. Recommended on all units to remove excess condensate. Packaged in quantities of ten.</p>	
<p>PXCJA</p>	<p>CONDUIT KIT WITH JUNCTION BOX Hard wire conduit kit with junction box for 208/230V and 265V units (subbase not required). Kit includes a means of quick disconnect for easy removal of the chassis. *Required for 265V installations.</p>	
<p>PDXDAA</p>	<p>LATERAL DUCT ADAPTER Attaches to the Friedrich PTAC/PTHP unit to direct up to 35% of the total airflow to a second room. The unit-mounted duct plenum features a front-mounted aluminum grille that has two positions to provide the most optimal air direction. The air may be directed to either the left or the right of the unit through the supplied 3¹/₂" H x 7" W x 47" L plenum. Plenum may be cut to length by the installer. Kit includes duct plenum, front grille, 47" duct extension, duct discharge grille, duct end cap and all necessary mounting hardware.</p>	
<p>PDXDEA</p>	<p>LATERAL DUCT EXTENSION Additional 3¹/₂" H x 7" W x 47" L plenum for use with the LATERAL DUCT ADAPTER. A maximum of 3 duct extensions total may be used. Note: Ducted airflow is reduced as duct length is increased.</p>	

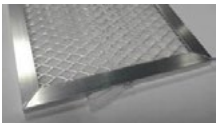





ACCESSORIES

New Construction Accessories																							
PXFTA	<p>REPLACEMENT FILTER PACK These are original equipment return air filters. They are reusable and can be cleaned by vacuuming, washing, or blowing out, and are sold in convenient ten-packs. (Two filters per chassis).</p>																						
PXFAFT10	<p>REPLACEMENT FILTER PACK Merv 8 filters. 10 pack. Each PTAC requires 1 filter.</p>																						
PXSBA	<p>DECORATIVE SUBBASE Provides unit support for walls less than six inches thick. Includes leveling legs, side filler panels and mounting brackets for electrical accessories. Accepts circuit breaker, power disconnect switch, or conduit kit.</p>																						
PXSB	<p>ELECTRICAL SUBBASE Provides unit support for walls less than six inches thick. Includes leveling legs, side filler panels, mounting brackets, a plug-in receptacle and field-wiring access. The subbase also includes electrical knockouts for a power disconnect switch or circuit breaker.</p> <table border="1" data-bbox="386 835 833 957"> <tr> <td>PXSB23020</td> <td>Electrical Subbase - 230V 15 & 20A</td> </tr> <tr> <td>PXSB23030</td> <td>Electrical Subbase - 230V 30A</td> </tr> <tr> <td>PXSB26515</td> <td>Electrical Subbase - 265V 15A</td> </tr> <tr> <td>PXSB26520</td> <td>Electrical Subbase - 265V 20A</td> </tr> <tr> <td>PXSB26530</td> <td>Electrical Subbase - 265V 30A</td> </tr> </table>	PXSB23020	Electrical Subbase - 230V 15 & 20A	PXSB23030	Electrical Subbase - 230V 30A	PXSB26515	Electrical Subbase - 265V 15A	PXSB26520	Electrical Subbase - 265V 20A	PXSB26530	Electrical Subbase - 265V 30A												
PXSB23020	Electrical Subbase - 230V 15 & 20A																						
PXSB23030	Electrical Subbase - 230V 30A																						
PXSB26515	Electrical Subbase - 265V 15A																						
PXSB26520	Electrical Subbase - 265V 20A																						
PXSB26530	Electrical Subbase - 265V 30A																						
PXPCFA	<p>POWER CORDS Universal power cords enable properties to select the appropriate heater size. Reference the adjacent table for power cord options</p> <p>*Cannot be used on PVH09K3FA.</p>	<table border="1" data-bbox="938 995 1487 1192"> <thead> <tr> <th></th> <th></th> <th>Length</th> </tr> </thead> <tbody> <tr> <td>PXPCFA23015</td> <td>LCDI 230V 15A Cord - 2.5 kW</td> <td>67 in.</td> </tr> <tr> <td>PXPCFA23020</td> <td>LCDI 230V 20A Cord - 3.5 kW</td> <td>67 in.</td> </tr> <tr> <td>PXPCFA23030*</td> <td>LCDI 230V 30A Cord - 5.0 kW</td> <td>67 in.</td> </tr> <tr> <td>PXPCFA26515</td> <td>Non-LCDI 265V 15A Cord - 2.5 kW</td> <td>27 1/2 in.</td> </tr> <tr> <td>PXPCFA26520</td> <td>Non-LCDI 265V 20A Cord - 3.5 kW</td> <td>27 1/2 in.</td> </tr> <tr> <td>PXPCFA26530*</td> <td>Non-LCDI 265V 30A Cord - 5.0 kW</td> <td>27 1/2 in.</td> </tr> </tbody> </table>			Length	PXPCFA23015	LCDI 230V 15A Cord - 2.5 kW	67 in.	PXPCFA23020	LCDI 230V 20A Cord - 3.5 kW	67 in.	PXPCFA23030*	LCDI 230V 30A Cord - 5.0 kW	67 in.	PXPCFA26515	Non-LCDI 265V 15A Cord - 2.5 kW	27 1/2 in.	PXPCFA26520	Non-LCDI 265V 20A Cord - 3.5 kW	27 1/2 in.	PXPCFA26530*	Non-LCDI 265V 30A Cord - 5.0 kW	27 1/2 in.
		Length																					
PXPCFA23015	LCDI 230V 15A Cord - 2.5 kW	67 in.																					
PXPCFA23020	LCDI 230V 20A Cord - 3.5 kW	67 in.																					
PXPCFA23030*	LCDI 230V 30A Cord - 5.0 kW	67 in.																					
PXPCFA26515	Non-LCDI 265V 15A Cord - 2.5 kW	27 1/2 in.																					
PXPCFA26520	Non-LCDI 265V 20A Cord - 3.5 kW	27 1/2 in.																					
PXPCFA26530*	Non-LCDI 265V 30A Cord - 5.0 kW	27 1/2 in.																					
RT7 RT7P	<p>DIGITAL REMOTE THERMOSTATS</p> <p>RT7 Wired single stage cool, single stage heat for PDE models or single stage cool, dual stage heat for PDH model thermostat features high/low fan speed switch. Thermostat is hard wired and can be battery powered or unit powered. Features backlit display and multiple configuration modes. For use on Friedrich PTACs and Vert-I-Paks.</p> <p>RT7P Wired, programmable single stage cool, single stage heat for PDE models or single stage cool, dual stage heat for PDH model thermostat features high/low fan speed switch. Thermostat is hard wired and can be battery powered or unit powered. Features backlit display and multiple configuration modes. For use on Friedrich PTACs and Vert-I-Paks.</p>	 																					



ACCESSORIES

New Construction Accessories		
<p>WRT2</p>	<p>WIRELESS DIGITAL REMOTE THERMOSTAT Single stage cool, single stage heat for PDE models or single stage cool, dual stage heat for PDH model thermostat features high/low fan speed switch. Thermostat is wireless and is battery powered. Features backlit display and multiple configuration modes. For use on Friedrich PTACs and Vert-I-Paks.</p>	
<p>PDXRTB</p>	<p>REMOTE THERMOSTAT ESCUTCHEON KIT This kit contains ten escutcheons that can be placed over the factory control buttons when a remote wall mounted thermostat is used. The escutcheon directs the guest to the wall thermostat for operation and retains the LED window to display error codes and diagnostic information.</p>	
<p>EMRT(A/B)4 EMWRT(A/B)4</p>	<p>ENERGY MANAGEMENT THERMOSTATS</p> <p>EMRTA4 (WHITE) / EMRTB4 (BLACK) Wired thermostat with occupancy sensor.</p> <p>EMWRTA4 (White) / EMWRTB4 (Black) Wireless thermostat with occupancy sensor.</p> <p>EMOCT EMRAF Online connection kit. Remote access fee.</p>	 <p>EMRT(A/B)4 EMWRT(A/B)4 EMOCT</p>
<p>VRPXEMRT(A/B)4 (Preferred FreshAire Thermostat)</p> <p>VRPXEMWRT(A/B)4</p> <p>VRPXEMWCTA4</p>	<p>(A-White) / (B-Black) Wired and wireless thermostat and occupancy sensor 12v. Full inverter control. Designed to maximize features and benefits of FreshAire system.</p> <p>(A-White) / (B-Black) Wireless wall controller and occupancy sensor-12v. Full inverter control. Designed to maximize features and benefits of FreshAire system.</p> <p>(White only) Wired thermostat without occupancy sensor 12V. Full inverter control. Designed to maximize features and benefits of FreshAire system.</p>	

*NOTE: The FreshAire PTAC must be paired with wall controller **VRPXEMRT(A/B)4** , **VRPXEMWRT(A/B)4** or **VRPXEMWCTA4** to operate as a fully variable speed unit. When used with other compatible thermostats, the unit will operate at multiple speeds in either cooling or heating mode.

*Cannot be used with PVH09K3FC

ACCESSORIES

Friedrich PTAC with *FreshAire*® IAQ

The COVID-19 global pandemic transformed the way the lodging industry meets the comfort and safety needs for guests. As your room air experts, Friedrich remains committed to improving guest comfort and safety with our newest innovation, FreshAire® IAQ solutions - a suite of indoor air quality accessories for use with Friedrich Air Conditioners, all with one dedicated purpose - healthy indoor air. FreshAire® IAQ solutions incorporate ASHRAE-recommended protocol* to address indoor air quality and airborne transmissions.

This suite of products include industry-leading air quality technologies such as MERV 13 filtration, UV germicidal light and bi-polar ionization. Together, they represent a major leap forward in integrated HVAC air purification and rebuilding confidence for indoor environments.

*Based on ASHRAE Guidance for Building Operations During the COVID-19 Pandemic

FreshAire® Make Up Air (MUA) & Filtration

Award-winning FreshAire MUA system helps achieve ASHRAE 62.1-2013 requirements, and brings up to 52 CFM of conditioned, MERV 8 filtered, outside air into the space. Patented FreshAire technology uses the Precision Inverter compressor and main cooling system to optimize temperature and humidity level of incoming air while MERV 8 filtration traps particles and pollutants.

Standard on FreshAire PTAC

FreshAire® Purifier APWM1

FreshAire Purifier by iWaves features needlepoint bi-polar ionization to address any mold, bacteria, virus, allergens, and VOC's that may be in your air stream to ensure delivery of healthy, clean, purified air.

Friedrich® UV UVT1

Germicidal UV light kits have been tested and certified for use on Friedrich PTACs. The UV kit can be installed on the fan coil and is designed to disinfect surfaces and the air as it circulates through the ventilation system. UV light can kill airborne bacteria, viruses, mold, reduce maintenance costs and extend the life of an HVAC system

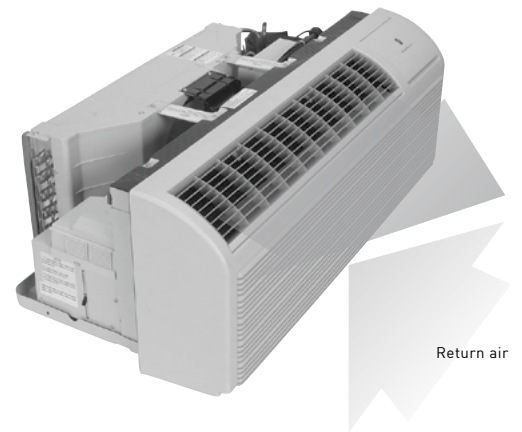



F R I E D R I C H

Friedrich Air Conditioning Co.
10001 Reunion Place, San Antonio, TX 78216
800.541.6645

www.friedrich.com

PV-SERIES PACKAGED TERMINAL AIR CONDITIONERS LIMITED WARRANTY

SAVE THIS CERTIFICATE. It gives you specific rights. You may also have other rights which may vary from state to state and province to province. In the event that your unit needs servicing, contact your nearest authorized service center. If you do not know the nearest service center, ask the company that installed your unit or contact us - see address and telephone number above. To obtain service and/or warranty parts replacement, you must notify an authorized FRIEDRICH Air Conditioning Co. service center, distributor, dealer, or contractor of any defect within the applicable warranty period.

When requesting service: please have the model and serialnumber from your unit readily available.

Unless specified otherwise herein, the following applies:
FRIEDRICH PACKAGED TERMINAL AIR CONDITIONERS AND HEAT PUMPS

LIMITED WARRANTY - FIRST YEAR (Twelve (12) months from the date of installation). Any part found to be defective in the material or workmanship will be repaired or replaced free of charge by our authorized service center during the normal working hours; and

LIMITED WARRANTY - SECOND THROUGH FIFTH YEAR (Sixty (60) months from the date of installation). ON THE SEALED REFRIGERATION SYSTEM. Any part of the sealed refrigeration system that is defective in material or workmanship will be repaired or replaced free of charge (excluding freight charges) by our authorized service center during normal working hours. The sealed refrigeration system consists of the compressor, metering device, evaporator, condenser, reversing valve, check valve, and the interconnecting tubing.

These warranties apply only while the unit remains at the original site and only to units installed inside the continental United States, Alaska, Hawaii, Puerto Rico, Mexico and Canada. The warranty applies only if the unit is installed and operated in accordance with the printed instructions and in compliance with applicable local installation and building codes and good trade practices. For international warranty information, contact the Friedrich Air Conditioning Company - International Division.

Any defective part to be replaced must be made available to **FRIEDRICH** in exchange for the replacement part. Reasonable proof must be presented to establish the date of install, otherwise the beginning date of this certificate will be considered to be our shipment date plus sixty days. Replacement parts can be new or remanufactured. Replacement parts and labor are only warranted for any unused portion of the unit's warranty.

We will not be responsible for and the user will pay for:

1. Service calls to:

A) Instruct on unit operation. B) Replace house fuses or correct house wiring. C) Clean or replace air filters. D) Remove the unit from its installed location when not accessible for service required. E) Correct improper installations.

2. Parts or labor provided by anyone other than an authorized service center.

3. Damage caused by:

A) Accident, abuse, negligence, misuse, riot, fire, flood, or acts of God. B) operating the unit where is a corrosive atmosphere containing chlorine, fluorine, or any damaging chemicals (other than in a normal residential environment). C) Unauthorized alteration or repair of the unit, which in turn affects its stability or performance. D) Failing to provide proper maintenance and service. E) Using an incorrect power source. F) Faulty installation or application of the unit. **G) Operation of the unit during Construction**

We shall not be liable for any incidental, consequential, or special damages or expenses in connection with any use or failure of this unit. We have not made and do not make any representation or warranty fitness for a particular use or purpose and there is no implied condition of fitness for a particular use or purpose. We make no expressed warranties except as stated in this certificate. No one is authorized to change this certificate or to create for us any other obligation or liability in connection with this unit. Any implied warranties shall last for one year after the original purchase date. Some states and provinces do not allow limitations on how long an implied warranty or condition lasts, so the above limitations or exclusions may not apply to you. The provisions of this warranty are in addition to and not a modification of or subtraction from the statutory warranties and other rights and other rights and remedies provided by law.

Performance of Friedrich's Warranty obligation is limited to one of the following methods:

1. Repair of the unit
2. A refund to the customer for the prorated value of the unit based upon the remaining warranty period of the unit.
3. Providing a replacement unit of equal value

The method of fulfillment of the warranty obligation is at the sole discretion of Friedrich Air Conditioning.

In case of any questions regarding the provisions of this warranty, the English version will govern.