

KitchenAid®

MICROWAVE OVEN

Use & Care Guide

For questions about features, operation/performance, parts, accessories or service, call: **1-800-422-1230**,
or visit our website at... www.kitchenaid.com

Table of Contents..... 2



Model KCMS1555R
8205541/3828W5A8155



TABLE OF CONTENTS

MICROWAVE OVEN SAFETY	3
INSTALLATION INSTRUCTIONS	5
Unpacking	5
Location Requirements	5
Electrical Requirements	5
PARTS AND FEATURES	6
Turntable	6
MICROWAVE OVEN CONTROL	6
Display	7
Start	7
Easy Start	7
Cancel	7
Clock	7
Tones.....	7
Timer.....	7
Control Lock.....	8
Demo Mode.....	8
Personal Choice	8
MICROWAVE OVEN USE	8
Food Characteristics	8
Cooking Guidelines	8
Cookware and Dinnerware	9
Aluminum Foil and Metal	9
Cooking Power.....	9
Cooking	10
Cooking in Stages.....	10
Custom Cooking	10
Custom Defrosting	11
Auto Sensor Cooking.....	11
Auto Sensor Popcorn.....	12
Auto Sensor Reheat	12
Keep Warm.....	12
MICROWAVE OVEN CARE	13
General Cleaning.....	13
TROUBLESHOOTING	14
ASSISTANCE OR SERVICE	15
Replacement Parts.....	15
Built-in Kits	15
WARRANTY	16



MICROWAVE OVEN SAFETY

Your safety and the safety of others are very important.

We have provided many important safety messages in this manual and on your appliance. Always read and obey all safety messages.



This is the safety alert symbol.

This symbol alerts you to potential hazards that can kill or hurt you and others.

All safety messages will follow the safety alert symbol and either the word “DANGER” or “WARNING.” These words mean:

⚠ DANGER

You can be killed or seriously injured if you don't immediately follow instructions.

⚠ WARNING

You can be killed or seriously injured if you don't follow instructions.

All safety messages will tell you what the potential hazard is, tell you how to reduce the chance of injury, and tell you what can happen if the instructions are not followed.

IMPORTANT SAFETY INSTRUCTIONS

When using electrical appliances basic safety precautions should be followed, including the following:

WARNING: To reduce the risk of burns, electric shock, fire, injury to persons or exposure to excessive microwave energy:

- Read all instructions before using the microwave oven.
- Read and follow the specific “PRECAUTIONS TO AVOID POSSIBLE EXPOSURE TO EXCESSIVE MICROWAVE ENERGY” found in this section.
- The microwave oven must be grounded. Connect only to properly grounded outlet. See “GROUNDING INSTRUCTIONS” found in the “Installation Instructions” section.
- Install or locate the microwave oven only in accordance with the installation instructions.
- Some products such as whole eggs and sealed containers – for example, closed glass jars – are able to explode and should not be heated in the microwave oven.
- Use the microwave oven only for its intended use as described in this manual. Do not use corrosive chemicals or vapors in the microwave oven. This type of oven is specifically designed to heat, cook, or dry food. It is not designed for industrial or laboratory use.
- As with any appliance, close supervision is necessary when used by children.
- Do not operate the microwave oven if it has a damaged cord or plug, if it is not working properly, or if it has been damaged or dropped.
- The microwave oven should be serviced only by qualified service personnel. Call an authorized service company for examination, repair or adjustment.
- Do not cover or block any openings on the microwave oven.
- Do not store the microwave oven outdoors. Do not use the microwave oven near water – for example, near a kitchen sink, in a wet basement, or near a swimming pool, or similar locations.
- Do not immerse cord or plug in water.
- Keep cord away from heated surfaces.
- Do not let cord hang over edge of table or counter.
- See door surface cleaning instructions in the “Microwave Oven Care” section.
- Do not operate any heating or cooking appliance beneath the microwave oven.
- Do not mount microwave oven over or near any portion of a heating or cooking appliance.
- Do not mount over a sink.
- Do not store anything directly on top of the microwave oven surface when the microwave oven is in operation.

SAVE THESE INSTRUCTIONS

IMPORTANT SAFETY INSTRUCTIONS

- To reduce the risk of fire in the oven cavity:
 - Do not overcook food. Carefully attend the microwave oven when paper, plastic, or other combustible materials are placed inside the oven to facilitate cooking.
 - Remove wire twist-ties from paper or plastic bags before placing bag in oven.
 - If materials inside the oven ignite, keep oven door closed, turn oven off, and disconnect the power cord, or shut off power at the fuse or circuit breaker panel.
 - Do not use the cavity for storage purposes. Do not leave paper products, cooking utensils, or food in the cavity when not in use.
- Liquids, such as water, coffee, or tea are able to be overheated beyond the boiling point without appearing to be boiling. Visible bubbling or boiling when the container is removed from the microwave oven is not always present. **THIS COULD RESULT IN VERY HOT LIQUIDS SUDDENLY BOILING OVER WHEN THE CONTAINER IS DISTURBED OR A SPOON OR OTHER UTENSIL IS INSERTED INTO THE LIQUID.**
To reduce the risk of injury to persons:
 - Do not overheat the liquid.
 - Stir the liquid both before and halfway through heating it.
 - Do not use straight-sided containers with narrow necks.
 - After heating, allow the container to stand in the microwave oven for a short time before removing the container.
 - Use extreme care when inserting a spoon or other utensil into the container.

SAVE THESE INSTRUCTIONS

PRECAUTIONS TO AVOID POSSIBLE EXPOSURE TO EXCESSIVE MICROWAVE ENERGY

- (a) Do not attempt to operate this oven with the door open since open-door operation can result in harmful exposure to microwave energy. It is important not to defeat or tamper with the safety interlocks.
- (b) Do not place any object between the oven front face and the door or allow soil or cleaner residue to accumulate on sealing surfaces.
- (c) Do not operate the oven if it is damaged. It is particularly important that the oven door close properly and that there is no damage to the:
 - (1) Door (bent),
 - (2) Hinges and latches (broken or loosened),
 - (3) Door seals and sealing surfaces.
- (d) The oven should not be adjusted or repaired by anyone except properly qualified service personnel.

This device complies with Part 18 of the FCC Rules.

INSTALLATION INSTRUCTIONS

Unpacking

1. Empty the microwave oven of any packing materials.
2. Clean the inside with a soft, damp cloth.
3. Check for damage, such as:
 - a door that is not lined up correctly
 - damage around the door, or
 - dents on the interior or exterior of the microwave oven.

If there is any damage, do not operate the microwave oven until a designated service technician has checked it and made any needed repairs.

Location Requirements

⚠ WARNING



Fire Hazard

Do not install the oven next to or over a heat source without a UL approved trim kit.

Doing so can result in death, fire, or electrical shock.

⚠ WARNING

Excessive Weight Hazard

Use two or more people to move and install microwave oven.

Failure to do so can result in back or other injury.

IMPORTANT: The control side of the unit is the heavy side. Handle the microwave oven gently. The weight of the microwave oven is more than 35 lbs (15.9 kg).

- Place the microwave oven on a cart, counter, table or shelf that is strong enough to hold the microwave oven and the food and utensils you place inside it.
- The microwave oven should be at a temperature above 50°F (10°C) for proper operation.

NOTE: Some models can be built into a wall or cabinet by using one of the trim kits listed in the “Microwave Oven Built-In Trim Kit Installation Instructions.”

- Do not block the exhaust vents or air intake openings. Allow a few inches of space at the back of the microwave oven where the exhaust vents are located. Blocking the exhaust vents could cause damage to the microwave oven, as well as poor cooking results.

- Make sure the microwave oven legs are in place to ensure proper airflow. If vents are blocked, a sensitive thermal safety device may automatically turn the microwave oven off. The microwave oven should work properly once it has cooled.

Electrical Requirements

⚠ WARNING



Electrical Shock Hazard

Plug into a grounded 3 prong outlet.

Do not remove ground prong.

Do not use an adapter.

Do not use an extension cord.

Failure to follow these instructions can result in death, fire, or electrical shock.

Observe all governing codes and ordinances. A 120 Volt, 60 Hz, AC only, 15- or 20-amp fused electrical supply (or circuit breaker) is required. (A time-delay fuse is recommended.) It is recommended that a separate circuit serving only this appliance be provided.

GROUNDING INSTRUCTIONS

- **For all cord connected appliances:**
The microwave oven must be grounded. In the event of an electrical short circuit, grounding reduces the risk of electric shock by providing an escape wire for the electric current. The microwave oven is equipped with a cord having a grounding wire with a grounding plug. The plug must be plugged into an outlet that is properly installed and grounded.

WARNING: Improper use of the grounding plug can result in a risk of electric shock. Consult a qualified electrician or serviceman if the grounding instructions are not completely understood, or if doubt exists as to whether the microwave oven is properly grounded.

Do not use an extension cord. If the power supply cord is too short, have a qualified electrician or serviceman install an outlet near the microwave oven.

SAVE THESE INSTRUCTIONS

PARTS AND FEATURES

This manual may cover several different models. The model you have purchased may have some or all of the features shown here. The appearance of your particular model may differ slightly from the illustrations in this manual.

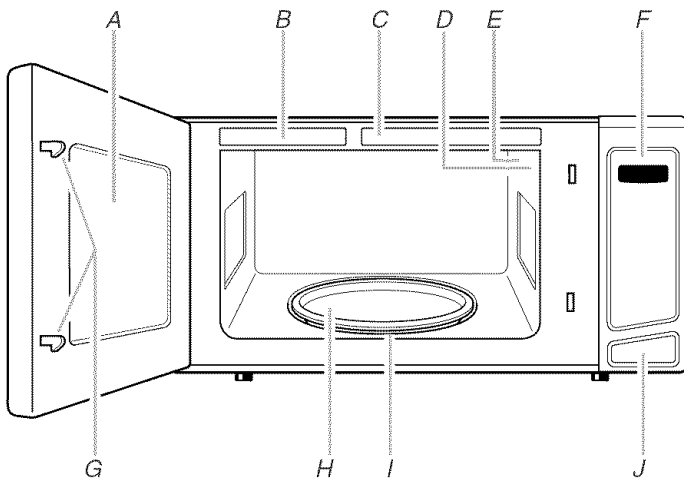

- A. Metal shielded window
- B. Model and serial number plate
- C. Cooking guide label
- D. Microwave oven light
- E. Microwave inlet cover
- F. Control panel
- G. Door safety lock system
- H. Glass turntable
- I. Turntable support
- J. Door open push button

Turntable

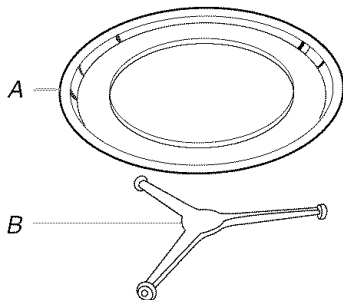

- A. Turntable
- B. Support

The turntable can rotate in either direction to help cook food more evenly. Do not operate the oven without having the turntable in place. See "Assistance or Service" to reorder any of the parts.

To Install:

1. Place the support on the oven cavity bottom.
2. Place the turntable on the support.

Fit the raised, curved lines in the center of the turntable bottom between the three spokes of the support. The rollers on the support should fit inside the turntable bottom ridge.

MICROWAVE OVEN CONTROL

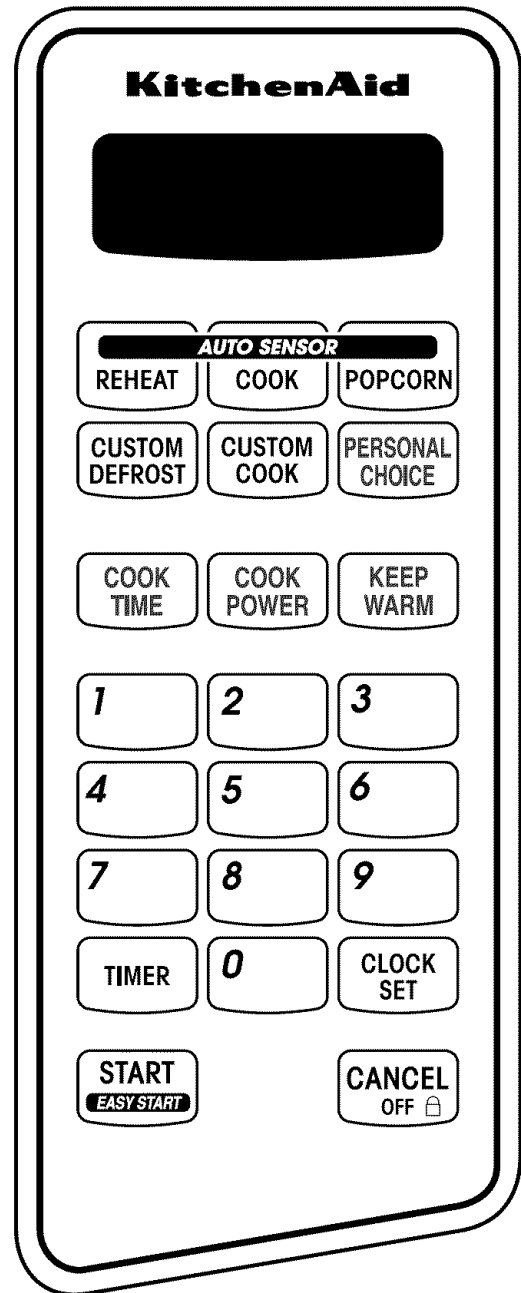

Display

When power is first supplied to the microwave oven, “:” will appear in the display. If the “:” appears in the display at any other time, a power failure has occurred. Reset the clock if needed.

When the microwave oven is in use, the display shows cook time remaining. When the microwave oven is not in use, the display shows the time of day (if the Clock is set) or Timer countdown.

Start

The START pad begins any function. If non-sensor cooking is interrupted, touching START will resume the preset cycle. Touching START will not resume an interrupted sensor cycle.

Easy Start

Cook time may be added to a manual cook cycle by touching the EASY START (START) pad. Touching EASY START during the cycle will add 30 seconds of cook time at the current cook power. Each additional touch adds 30 seconds of cook time, up to 3 minutes, then 1 minute of cook time, up to 10 minutes.

The EASY START pad will also start the microwave oven at 100% power for 30 seconds after the door is closed or CANCEL is touched. Additional time may be added by touching EASY START.

Cancel

The CANCEL pad clears any incorrect command and cancels most functions except for the Timer and Control Lock. It will not erase the time of day.

The oven will also turn off when the door is opened. Close the door and touch START to resume the non-sensor cycle.

Clock

This is a 12-hour or 24-hour clock.

To Set Clock:

The microwave oven and Timer must be off.

1. Touch CLOCK SET.
2. Touch number pads to correct time of day.
3. Touch CLOCK SET.

The hour format may be changed, and the clock may be hidden using Personal Choice.

To Change Clock Display:

1. Touch PERSONAL CHOICE 5 times.
“Clock” will appear in the display, then instructions will scroll.
2. Touch “1” for 12-hour format, “2” for 24-hour format, or “3” to turn off.
3. Touch START.

When the clock is turned off, the display will be blank.

Tones

Tones are audible signals, indicating the following:

One tone

- Valid entry
- Hidden feature entered

Two tones

- End of stage in multistage cooking
- Invalid entry (short tones)
- Every minute after end-of-cycle tones, as reminder
- Hidden feature exited

Three tones

- End of cycle

Five tones

- End of Timer countdown
- During defrost cycle, as reminder to check, turn, rearrange, or separate food

Tone volume may be adjusted, or the tones may be disabled using Personal Choice.

To Change Tones Settings:

1. Touch PERSONAL CHOICE.
“Sound Volume” will appear in the display, then instructions will scroll.
 2. Touch “1” for low volume, “2” for medium, “3” for high, or touch “4” to turn off tones.
 3. Touch START.
-

Timer

The Timer can be set in minutes and seconds, up to 99 minutes, 99 seconds, and counts down the set time.

NOTE: The Timer does not start or stop the microwave oven.

Cook functions may be used while the Timer is counting down. When the cook function is active in the display, touch TIMER to see the Timer countdown for 5 seconds.

To Set:

1. Touch TIMER.
2. Touch number pads to enter desired time.
3. Touch TIMER or START, or allow the Timer to start automatically after a brief delay.
When the set time ends, “TIMER END” will scroll across the display and the end-of-Timer tones will sound.
4. Touch TIMER at anytime while the Timer countdown is active in the display to cancel the Timer.
Remember, touching CANCEL will turn off the microwave oven.

The time can be reset during the countdown by repeating the above steps.

Control Lock

The Control Lock shuts down the control panel pads to prevent unintended use of the microwave oven. If any pad is touched while the Control Lock is active, "LOCKED" will appear in the display.

To Lock/Unlock Control: Touch and hold CANCEL for approximately 5 seconds until 1 tone sounds and "LOCKED" appears in the display. Repeat to unlock the control. Two tones will sound, and "UNLOCK" will appear in the display.

Demo Mode

The Demo Mode is ideal for learning how to use the microwave oven. When set, functions can be entered without actually turning on the magnetron. While functions are operating in the Demo Mode, the microwave oven light will come on, the fan will run, the countdown will run very quickly in the display, and if turned on, the turntable will rotate, and the tones will sound.

To Turn On/Off Demo Mode: Touch and hold TIMER for 5 seconds until 1 tone sounds, and "DEMO ON" appears in the display. Repeat to turn off Demo Mode.

Personal Choice

Settings can be selected, and displays can be changed by touching PERSONAL CHOICE.

TOUCH PAD	SETTING	NUMBER PAD = OPTION
Once	Sound volume	1=Low, 2=Medium, 3=High, 4=Off
Twice	Weight	1=lbs, 2=kgs
3 times	Language	1=English, 2=French, 3=Spanish
4 times	Scroll speed	1=Slow, 2=Medium, 3=Fast
5 times	Clock	1=12 hrs, 2=24 hrs, 3=Off

1. Touch PERSONAL CHOICE repeatedly to scroll through the settings until the desired setting is displayed. Instructions for that setting will scroll across the display.
 2. Touch the appropriate number pad to select the desired setting option.
 3. Touch START.
-

MICROWAVE OVEN USE

A magnetron in the oven produces microwaves which reflect off the metal floor, walls and ceiling and pass through the turntable and appropriate cookware to the food. Microwaves are attracted to and absorbed by fat, sugar and water molecules in the food, causing them to move, producing friction and heat which cooks the food.

- Do not lean on or allow children to swing on the microwave oven door.
- Do not operate microwave oven when it is empty.
- The turntable must be in place and correct side up when microwave oven is in use. Do not use if turntable is chipped or broken. See "Assistance or Service" section to reorder.
- Baby bottles and baby food jars should not be heated in microwave oven.
- Clothes, flowers, fruit, herbs, wood, gourds, paper, including brown paper bags and newspaper, should not be dried in microwave oven.
- Do not use the microwave oven for canning, sterilizing or deep frying. The microwave oven cannot maintain appropriate temperatures.
- Paraffin wax will not melt in the microwave oven because it does not absorb microwaves.
- Use oven mitts or pot holders when removing containers from microwave oven.
- Do not overcook potatoes. At the end of the recommended cook time, potatoes should be slightly firm. Let potatoes stand for 5 minutes. They will finish cooking while standing.
- Do not cook or reheat whole eggs inside the shell. Steam buildup in whole eggs may cause them to burst. Cover poached eggs and allow a standing time.

Food Characteristics

When microwave cooking, the amount, size and shape, starting temperature, composition and density of the food affect cooking results.

Amount of Food

The more food heated at once, the longer the cook time. Check for doneness and add small increments of time if necessary.

Size and Shape

Smaller pieces of food will cook more quickly than larger pieces, and uniformly shaped foods cook more evenly than irregularly shaped food.

Starting Temperature

Room temperature foods will heat faster than refrigerated foods, and refrigerated foods will heat faster than frozen foods.

Composition and Density

Foods high in fat and sugar will reach a higher temperature, and will heat faster than other foods. Heavy, dense foods, such as meat and potatoes, require a longer cook time than the same size of a light, porous food, such as cake.

Cooking Guidelines

Covering

Covering food helps retain moisture, shorten cook time and reduce spattering. Use the lid supplied with cookware. If a lid is not available, wax paper, paper towels or plastic wrap approved for microwave ovens may be used. Plastic wrap should be turned back at one corner to provide an opening to vent steam. Condensation on the door and cavity surfaces is normal during heavy cooking.

Stirring and Turning

Stirring and turning redistribute heat evenly to avoid overcooking the outer edges of food. Stir from outside to center. If possible, turn food over from bottom to top.

Arranging

If heating irregularly shaped or different sized foods, arrange the thinner parts and smaller sized items toward the center. If cooking several items of the same size and shape, place them in a ring pattern, leaving the center of the ring empty.

Piercing

Before heating, use a fork or small knife to pierce or prick foods that have a skin or membrane, such as potatoes, egg yolks, chicken livers, hot dogs, and sausage. Prick in several places to allow steam to vent.

Shielding

Use small, flat pieces of aluminum foil to shield the thin pieces of irregularly shaped foods, bones and foods such as chicken wings, leg tips and fish tail. See "Aluminum Foil and Metal" first.

Standing Time

Food will continue to cook by the natural conduction of heat even after the microwave cooking cycle ends. The length of standing time depends on the volume and density of the food.

Cookware and Dinnerware

Cookware and dinnerware must fit on the turntable. Always use oven mitts or pot holders when handling because any dish may become hot from heat transferred from the food. Do not use cookware and dinnerware with gold or silver trim. Use the following chart as a guide, then test before using.

MATERIAL	RECOMMENDATIONS
Aluminum Foil, Metal	See "Aluminum Foil and Metal" section.
Browning Dish	Bottom must be at least 3/16" (5 mm) above the turntable. Follow manufacturer's recommendations.
Ceramic Glass, Glass	Acceptable for use.
China, Earthenware	Follow manufacturer's recommendations.
Melamine	Follow manufacturer's recommendations.
Paper Towels, Dinnerware, Napkins	Use nonrecycled and those approved by the manufacturer for microwave oven use.
Plastic Wraps, Bags, Covers, Dinnerware, Containers	Use those approved by the manufacturer for microwave oven use.
Pottery and Clay	Follow manufacturer's recommendations.
Styrofoam*	Do not use in microwave oven.
Straw, Wicker, Wooden Containers	Do not use in microwave oven.
Wax Paper	Acceptable for use.

To Test Cookware or Dinnerware for Microwave Use:

- Put cookware or dinnerware in microwave oven with 1 cup (250 mL) of water beside it.
- Cook at 100% cooking power for 1 minute.

Do not use cookware or dinnerware if it becomes hot and the water stays cool.

Aluminum Foil and Metal

Always use oven mitts or pot holders when removing dishes from the microwave oven.

Aluminum foil and some metal can be used in the microwave oven. If not used properly, arcing (a blue flash of light) can occur and cause damage to the microwave oven.

OK for Use

Racks and bakeware supplied with the microwave oven (on some models), aluminum foil for shielding, and approved meat thermometers may be used with the following guidelines:

- Do not allow aluminum foil or metal to touch the inside cavity walls, ceiling or floor.
- Always use the turntable.
- Do not allow contact with another metal object during cooking.

Do Not Use

Metal cookware and bakeware, gold, silver, pewter, non-approved meat thermometers, skewers, twist ties, foil liners such as sandwich wrappers, staples and objects with gold or silver trim or a metallic glaze should not be used in the microwave oven.

Cooking Power

Many recipes for microwave cooking specify which cooking power to use by percent, name or number. For example, 70%=7=Medium-High.

Use the following chart as a general guide for the suggested cooking power of specific foods.

PERCENT/ NAME	NUMBER	USE
100%, High (default setting)	10	Quick heating convenience foods and foods with high water content, such as soups, beverages and most vegetables.
90%	9	Cooking small, tender pieces of meat, ground meat, poultry pieces and fish fillets. Heating cream soups.
80%	8	Heating rice, pasta or casseroles. Cooking and heating foods that need a cook power lower than high. For example, whole fish and meat loaf.
70%, Medium-High	7	Reheating a single serving of food.
60%	6	Cooking sensitive foods such as cheese and egg dishes, pudding and custards. Cooking non-stirrable casseroles, such as lasagna.

PERCENT/ NAME	NUMBER	USE
50%, Medium	5	Cooking ham, whole poultry and pot roasts. Simmering stews.
40%	4	Melting chocolate. Heating bread, rolls and pastries.
30%, Medium-Low, Defrost	3	Defrosting bread, fish, meats, poultry and precooked foods.
20%	2	Softening butter, cheese, and ice cream.
10%, Low	1	Taking chill out of fruit.

Cooking

To Use:

1. Touch COOK TIME.
"STAGE 1" will appear briefly, then "ENTER COOK TIME" will scroll across display. Enter the length of time to cook.
If cooking with 100% power, skip Step 2.
2. Touch COOK POWER, then set the desired cooking power. See "Cooking Power."
3. Touch START.
When the cycle ends, "END" will appear in the display, and the end-of-cycle tones will sound, followed by reminder tones.
4. Touch CANCEL or open the door to clear the display.
Cook time may be added in 30-second increments during the cycle by touching EASY START (START).

Cooking in Stages

The microwave oven can be set to cook at different cooking powers for various lengths of time, up to 3 stages, plus a warming stage.

To Cook in Stages:

1. Touch COOK TIME.
"STAGE 1" will appear briefly, then "ENTER COOK TIME" will scroll across display. Enter the length of time to cook during the 1st stage.
2. Touch COOK POWER, then enter the desired cooking power for the 1st stage. See "Cooking Power."
3. Repeat steps 1 and 2 for each additional stage.
Keep Warm may be programmed to follow the last stage by touching KEEP WARM at any time during stage programming.
4. Touch START.
Two tones will sound between stages.
When the cycle ends, "END" will appear in the display, and the end-of-cycle tones will sound, followed by reminder tones.
5. Touch CANCEL or open the door to clear the display and/or stop reminder tones.
Cook time may be added in 30-second increments during the cycling stage by touching EASY START (START).

Custom Cooking

Times and cooking power have been preset for certain microwavable foods. Use the following chart as a guide.

FOOD	NO.	QUANTITY/INSTRUCTIONS
Bacon*	1	2-6 slices, average thickness/ Follow package directions.
Beverage	2	1 or 2 cups, 8 oz (250 mL) each/ Do not cover. The diameter of the cup's opening will affect how the liquid heats. Beverages in cups with smaller openings may heat faster.
Frozen Roll/Muffin (prebaked)	3	1-4 pieces, 2 oz (57 g) each**/ Place on paper towel.
Fresh Roll/Muffin (prebaked)	4	1-4 pieces, 2 oz (57 g) each**/ Place on paper towel.
Oatmeal	5	1-6 servings/ Follow package directions. Use microwavable bowls with high sides.

*Differences in the amount of fat, meat, thickness, and curing process affect results. Average is 16 slices per pound.

**For smaller rolls, 2 rolls may be counted as 1 piece.

To Use Custom Cook:

1. Touch CUSTOM COOK repeatedly to scroll through foods
or
Touch number pad of desired food type from chart.
2. Enter quantity.
3. Touch START or wait for the microwave oven to start automatically after a brief delay.
The display will count down the cook time.
When the cycle ends, "END" will appear in the display, and the end-of-cycle tones will sound, followed by reminder tones.
4. Touch CANCEL or open the door to clear the display and/or stop reminder tones.

Custom Defrosting

The Custom Defrost feature's preset programs can be used or the microwave oven can be manually set to defrost. To defrost manually, use 30% cook power. Refer to a reliable cookbook for defrosting information.

- Food should be 0°F (-18°C) or colder at defrosting for optimal results. How foods are stored can affect results.
- Unwrap foods and remove lids (for example, from fruit juice containers) before defrosting.
- Shallow packages will defrost more quickly than thick blocks.
- Separate food pieces as soon as possible during or at the end of the cycle for more even defrosting.
- Use small pieces of aluminum foil to shield parts of food such as chicken wings, leg tips and fish tails. See "Aluminum Foil and Metal" first.

The Custom Defrost feature has preset times and cook powers for 3 categories: Meat, Poultry and Fish. Custom Defrost should not be used for food that has been left outside the freezer for more than 20 minutes, or for frozen ready-made food. Use the following chart as a guide.

MEAT

<i>Beef:</i> ground, steaks, roast, stew	The narrow or fatty areas of irregular shaped cuts should be shielded with foil before defrosting.
<i>Lamb:</i> stew and chops	
<i>Pork:</i> chops, ribs, roasts, sausage	Do not defrost less than 1/4 lb (113 g) or two 4 oz (113 g) patties. Place all meats in microwavable baking dish. Do not cover.

POULTRY

<i>Chicken:</i> whole and cut up	Place in microwavable baking dish, chicken breast side up.
<i>Cornish hens</i>	Do not cover.
<i>Turkey:</i> breast	

FISH

<i>Filletts, Steaks, Whole, Shellfish</i>	Place in microwavable baking dish. Do not cover.
---	--

To Use Custom Defrost:

1. Touch CUSTOM DEFROST.
The display will show the setting for defrosting Meat. Touch CUSTOM DEFROST a second time for the Poultry setting, and a third time for the Fish setting.
2. Enter the weight.
Weight can be set from 0.1 lb to 6.0 lbs (45 g to 2.7 kg).
3. Touch START.
The display will count down the defrost time.
During defrosting, 5 short tones will sound. These tones indicate it is time to check, turn, rearrange or separate food. Open door, turn food if necessary, close door and touch START to resume defrosting.
When the cycle ends, "END" will appear in the display, and the end-of-cycle tones will sound, followed by reminder tones.
4. Touch CANCEL or open the door to clear the display and/or stop reminder tones.

Auto Sensor Cooking

The sensor in the microwave oven detects humidity released from the food and automatically sets a cooking time based on the selected food category.

Use the following chart as a guide.

FOOD	QUANTITY	INSTRUCTIONS
Baked Potatoes	1-4 medium, 10-13 oz (283-369 g) each	Pierce each one several times with a fork. Place on turntable around edges, at least 1" (2.5 cm) apart. Let stand 5 minutes after cooking.
Frozen Vegetables	1-4 cups (250 mL-1 L)	Remove from package. Place in microwavable container. Cover with plastic wrap and vent. Stir and let stand 2-3 minutes after cooking.
Fresh Vegetables	1-4 cups (250 mL-1 L)	Place in microwavable container and add 2-4 tbs (30-60 mL) water. Cover with plastic wrap and vent. Stir and let stand 2-3 minutes after cooking.
Frozen Entrée	10-20 oz (283-567 g)	Remove from package. Loosen cover on three sides. If it is not in microwavable container, place on plate, cover with plastic wrap and vent.
Rice	0.5-2 cups (125-500 mL) dry rice (Use medium or long grain rice.)	Follow measurements on package for ingredient amounts. Place rice and liquid in microwavable dish. Cover with loose-fitting lid. Let stand 5 minutes after cooking, or until liquid is absorbed. Stir.
Fish	0.25-2 lbs (113-907 g)	Place in microwavable dish. Cover with plastic wrap and vent. Let stand 2-3 minutes after cooking.
Seafood		

NOTE: When covering foods, make sure the vent opening is large enough for moisture to escape. This will allow the sensor to accurately determine cooking time.

To Use Auto Cook:

Before using, make sure the microwave oven has been plugged in for at least 3 minutes, the room temperature is not above 95°F (35°C), and the outside of the container and microwave oven cavity are dry.

1. Place food on the turntable and close the door.
2. Touch COOK (AUTO SENSOR COOK) until the desired food type is displayed.
The microwave oven will start automatically after a brief delay.
When the cycle ends, "END" will appear in the display, and the end-of-cycle tones will sound, followed by reminder tones.
3. Touch CANCEL or open the door to clear the display and/or stop reminder tones.

Auto Sensor Popcorn

The sensor in the microwave oven determines the appropriate popping time of commercially packaged microwavable popcorn.

- Do not use regular paper bags or glassware.
- Pop only 1 package of popcorn at a time.
- Follow manufacturer's instructions when using a microwave popcorn popper.
- Listen for popping to slow to 1 pop every 1 or 2 seconds, then stop the cycle. Do not try to pop unpopped kernels.
- Use fresh bags of popcorn for optimal results.
- Cooking results may vary by brand and fat content.

There are 2 popcorn functions: Regular and Snack. Use Regular for bag sizes 3.5 oz (99 g) and 3.0 oz (85 g). Use Snack for bag size 1.75 oz (50 g).

To Use Auto Sensor Popcorn:

1. Place popcorn bag on the turntable.
2. Touch POPCORN once for Regular, or twice for Snack. Touch START, or wait for the oven to start the popping cycle automatically.
When the cycle ends, "END" will appear in the display, and the end-of-cycle tones will sound, followed by reminder tones.
3. Touch CANCEL or open the door to clear the display and/or stop reminder tones.

Auto Sensor Reheat

A sensor in the microwave oven detects humidity released from the food and automatically sets a reheating time based on the selection. Use the following chart as a guide.

FOOD	SERVING SIZE/INSTRUCTIONS
Dinner Plate (refrigerated)	8-16 oz (227-454 g) Place food on microwavable plate, cover with plastic wrap and vent.
Soup	1-4 cups (250 mL-1 L) Place in microwavable container, cover with plastic wrap and vent. Stir and let stand 2-3 minutes after reheating.
Sauce	1-4 cups (250 mL-1 L) Place in microwavable container, cover with plastic wrap and vent. Stir and let stand 2-3 minutes after reheating.
Casserole (refrigerated)	1-2 cups (250-500 mL) Place in microwavable container, cover with plastic wrap and vent. Stir and let stand 2-3 minutes after reheating.

NOTE: When covering foods, make sure the vent opening is large enough for moisture to escape. This will allow the sensor to accurately determine reheating time.

To Use Auto Sensor Reheat:

Before using, make sure the microwave oven has been plugged in for at least 3 minutes, the room temperature is not above 95°F (35°C), and the outside of the container and microwave oven cavity are dry.

1. Place food on the turntable and close the door.
2. Touch REHEAT until the desired food type is displayed. The microwave oven will start automatically after a brief delay.
When the cycle ends, "END" will appear in the display, and the end-of-cycle tones will sound, followed by reminder tones.
3. Touch CANCEL or open the door to clear the display and/or stop reminder tones.

Keep Warm

WARNING

Food Poisoning Hazard

Do not let food sit in oven more than one hour before or after cooking.

Doing so can result in food poisoning or sickness.

Hot cooked food can be kept warm in the microwave oven. Keep Warm can be used by itself, or it can be programmed to follow a cooking cycle. Opening the door during Keep Warm will cancel the function.

To Use:

Put hot cooked food in the microwave oven. Cover plates of food and foods that were cooked covered. Pastries, pies, turnovers, etc. should remain uncovered.

1. Touch KEEP WARM.
"WARM HOLD" will scroll twice, and then "START" will flash.
2. Touch START.
"WARM" will appear in the display during the entire cycle.
When the cycle ends, "END" will appear in the display, and the end-of-cycle tones will sound, followed by reminder tones.
3. Touch CANCEL or open the door to clear the display and/or stop reminder tones.

To Set at end of cycle: Touch KEEP WARM while setting a cooking cycle before touching START.

MICROWAVE OVEN CARE

General Cleaning

IMPORTANT: Before cleaning, make sure all controls are off and the microwave oven is cool. Always follow label instructions on cleaning products.

Soap, water and a soft cloth or sponge are suggested first unless otherwise noted.

OVEN CAVITY

Do not use soap-filled scouring pads, abrasive cleaners, steel-wool pads, gritty washcloths or some recycled paper towels. Damage may occur.

On stainless steel models, rub in direction of grain to avoid damaging.

The area where the oven door and frame touch when closed should be kept clean.

Average soil

- Mild, nonabrasive soaps and detergents:
Rinse with clean water and dry with soft, lint-free cloth.

Heavy soil

- Mild, nonabrasive soaps and detergents:
Heat 1 cup (250 mL) of water for 2 to 5 minutes in oven. Steam will soften soil. Rinse with clean water and dry with soft, lint-free cloth.

Odors

- Lemon juice or vinegar:
Heat 1 cup (250 mL) of water with 1 tbs (15 mL) of either lemon juice or vinegar for 2 to 5 minutes in oven.

Microwave Inlet Cover

The microwave inlet cover (see "Parts and Features") should be kept clean to avoid arcing and oven damage.

- Wipe with wet cloth.

OVEN DOOR AND EXTERIOR

The area where the oven door and frame touch when closed should be kept clean.

- Mild, nonabrasive soaps and detergents:
Rinse with clean water and dry with soft, lint-free cloth.
- Glass cleaner and paper towels or nonabrasive plastic scrubbing pad:
Apply glass cleaner to towel, not directly to surface.

Stainless Steel (on some models)

Do not use soap-filled scouring pads, abrasive cleaners, steel-wool pads, gritty washcloths or some paper towels. Damage may occur.

Rub in direction of grain to avoid damaging.

- Stainless Steel Cleaner & Polish (not included):
See "Assistance or Service" section to order.
- Liquid detergent or all-purpose cleaner:
Rinse with clean water and dry with soft, lint-free cloth.
- Vinegar for hard water spots

CONTROL PANEL

- Sponge or soft cloth and water:
Dampen sponge with water and wipe panel. Dry with soft cloth.
- Do not use chemical or abrasive cleansers.

TURNTABLE

Replace turntable immediately after cleaning. Do not operate the microwave oven without the turntable in place.

- Mild cleanser and scouring pad
- Dishwasher

TROUBLESHOOTING

Try the solutions suggested here first in order to avoid the cost of an unnecessary service call.

Nothing will operate

- **Has a household fuse blown, or has a circuit breaker tripped?**
Replace the fuse or reset the circuit.

Oven will not operate

- **Is the door completely closed?**
Firmly close door.
- **Is a spacer (on some models) attached to the inside of the door?**
Remove spacer, then firmly close door.
- **Is the electronic microwave oven control set correctly?**
See "Microwave Oven Control" section.
- **On some models, is the Control Lock set?**
See "Control Lock" section.
- **On some models, is the Demo Mode in use?**
See "Demo Mode" section.
- **Is the magnetron working properly?**
Try to heat 1 cup (250 mL) of cold water for 2 minutes at 100% cooking power. If water does not heat, call for service. See "Assistance or Service" section.

Oven makes humming noise

- This is normal and occurs when the power supply switches the magnetron on and off.

Oven door looks wavy

- This is normal and will not affect performance.

Turntable will not operate

- **Is the turntable properly in place?**
Make sure turntable is correct side up and is sitting securely on the turntable support.
- **Is the turntable support operating properly?**
Remove turntable. Remove and replace turntable support. Replace turntable. Place 1 cup (250 mL) of water on the turntable, then restart microwave oven. If it still is not working, call for service. See "Assistance or Service" section. Do not operate the microwave oven without turntable and turntable support working properly.

Turntable rotates both directions

- This is normal and depends on motor rotation at beginning of cycle.

Display shows messages

- **Is the display showing ":"?**
The clock has not been set. See "Display" section to clear display. See "Clock" section to reset the clock.
- **Is the display showing a letter followed by a number?**
See "Display" section to clear. If it reappears, call for service. See "Assistance or Service" section.

Display shows time countdown, but is not operating

- **Is the Timer in use?**
See "Timer" section.
- **On some models, is the Demo Mode in use?**
See "Demo Mode" section.

Tones are not sounding

- **Are tones turned off?**
See "Tones" section.

Fan running slower than usual

- **Has the microwave oven been stored in a cold area?**
The fan will run slower until the microwave oven warms up to normal room temperature.

Fan running during cooking

- This is normal. Fan comes on at low speed to cool the microwave oven.

Cooking times seem too long

- **Is the cooking power set properly?**
See "Cooking Power" section.
- **Are large amounts of food being heated?**
Larger amounts of food need longer cooking times.
- **Is the incoming voltage less than specified in "Microwave Oven Safety?"**
Have a qualified electrician check the electrical system in the home.

Interference with radio, TV, cordless phone, etc.

- **Is the microwave oven plugged into the same outlet?**
Try a different outlet.
- **Is the radio or TV receiver near the microwave oven?**
Move the receiver away from the microwave oven, or adjust the radio or TV antenna.
- **Are the microwave oven door and sealing surfaces clean?**
Make sure these areas are clean.
- **Is the cordless phone frequency 2.4 GHz?**
Some 2.4 GHz-based cordless phones and home wireless networks may experience static or noise while the microwave oven is on. Use a corded phone or a different frequency cordless phone, or avoid using these items during oven operation.

ASSISTANCE OR SERVICE

Before calling for assistance or service, please check "Troubleshooting." It may save you the cost of a service call. If you still need help, follow the instructions below.

When calling, please know the purchase date and the complete model and serial number of your appliance. This information will help us to better respond to your request.

If you need replacement parts

If you need to order replacement parts, we recommend that you use only factory specified parts. These factory specified parts will fit right and work right because they are made with the same precision used to build every new KITCHENAID® appliance.

To locate factory specified parts in your area, call us or your nearest KitchenAid designated service center.

In the U.S.A.

Call the KitchenAid Customer eXperience Center toll free:

1-800-422-1230.

Our consultants provide assistance with:

- Features and specifications on our full line of appliances.
- Installation information.
- Accessory and repair parts sales.
- Specialized customer assistance (Spanish speaking, hearing impaired, limited vision, etc.).
- Referrals to local dealers, repair parts distributors, and service companies. KitchenAid designated service technicians are trained to fulfill the product warranty and provide after-warranty service, anywhere in the United States.

To locate the KitchenAid designated service company in your area, you can also look in your telephone directory Yellow Pages.

For further assistance

If you need further assistance, you can write to KitchenAid with any questions or concerns at:

KitchenAid Brand Home Appliances
Customer eXperience Center
553 Benson Road
Benton Harbor, MI 49022-2692

Please include a daytime phone number in your correspondence.

Replacement Parts

Turntable Part No. 8205147	Turntable Rollers Part No. 8205149
Turntable Support/Roller Assembly Part No. 8205148	Stainless Steel Cleaner & Polish Part No. 8171420

Built-in Kits

This countertop microwave oven can be built in by using one of the following trim kits*. These kits are available from the dealer or can be ordered by kit model number. See "Assistance or Service" section for the Customer eXperience Center's toll-free number.

KIT SIZE	KIT MODEL NUMBERS/ COLORS	FOR INSTALLATION OVER OVEN MODELS
24" (61 cm)	MK1154XPQ / White MK1154XPB / Black MK1154XPS / Stainless	KEBI141D KEBS147D
27" (69 cm)	MK1157XPQ / White MK1157XPB / Black MK1157XPS / Stainless	KEBI171D KEBS177D
30" (76 cm)	MK1150XPQ / White MK1150XPB / Black MK1150XPS / Stainless	KEBI101D KEBS107D

*Approved, electric single microwave ovens only

KITCHENAID® MICROWAVE OVEN WARRANTY

ONE-YEAR FULL WARRANTY

For one year from the date of purchase, when this appliance is operated and maintained according to instructions attached to or furnished with this product, KitchenAid will pay for factory specified parts and repair labor costs to correct defects in materials or workmanship. Service must be provided by a KitchenAid designated service company.

SECOND THROUGH FIFTH YEAR LIMITED WARRANTY ON MAGNETRON TUBE, ELECTRIC OVEN ELEMENT AND SOLID STATE TOUCH CONTROL SYSTEM

In the second through fifth years from the date of purchase, when this appliance is operated and maintained according to instructions attached to or furnished with this product, KitchenAid will pay for factory specified parts for the microwave magnetron tube, any electric oven element and the solid state touch control system to correct defects in materials or workmanship.

SECOND THROUGH TENTH YEAR LIMITED WARRANTY ON STAINLESS STEEL OVEN CAVITY/INNER DOOR

In the second through tenth years from date of purchase, when this appliance is operated and maintained according to instructions attached to or furnished with this product, KitchenAid will pay for factory specified parts for the stainless steel oven cavity/inner door if the part rusts through due to defects in materials or workmanship.

KitchenAid will not pay for:

1. Service calls to correct the installation of your appliance, to instruct you how to use your appliance, to replace house fuses or correct house wiring, or to replace owner-accessible light bulbs.
2. Repairs when your appliance is used in other than normal, single-family household use.
3. Pickup and delivery. Your appliance is designed to be repaired in the home.
4. Damage resulting from accident, alteration, misuse, abuse, fire, flood, improper installation, acts of God or use of products not approved by KitchenAid.
5. Repairs to parts or systems resulting from unauthorized modifications made to the appliance.
6. Replacement parts or repair labor costs for units operated outside the United States.
7. Any labor costs during the limited warranty periods.

KITCHENAID SHALL NOT BE LIABLE FOR INCIDENTAL OR CONSEQUENTIAL DAMAGES.

Some states do not allow the exclusion or limitation of incidental or consequential damages, so this exclusion or limitation may not apply to you. This warranty gives you specific legal rights, and you may also have other rights which vary from state to state.

Outside the 50 United States, this warranty does not apply. Contact your authorized KitchenAid dealer to determine if another warranty applies.

If you need service, first see the "Troubleshooting" section of this book. After checking "Troubleshooting," additional help can be found by checking the "Assistance or Service" section or by calling the KitchenAid Customer eXperience Center, **1-800-422-1230** (toll-free), from anywhere in the U.S.A.

11/04

Keep this book and your sales slip together for future reference. You must provide proof of purchase or installation date for in-warranty service.

Write down the following information about your appliance to better help you obtain assistance or service if you ever need it. You will need to know your complete model number and serial number. You can find this information on the model and serial number label/plate, located on your appliance as shown in the "Parts and Features" section.

Dealer name _____
Address _____
Phone number _____
Model number _____
Serial number _____
Purchase date _____