

Zip Filter Tap

Cold Water Filtration (unchilled)

Affix Model Number Label Here
801085



Read These Warnings First

Please read all Warnings, Installation Requirements and Installation Instructions before installing any Zip Filter Tap.

These appliances are not intended for use by persons (including children) with reduced physical, sensory or mental capabilities, or lack of experience and knowledge, unless they have been given supervision or instruction concerning use of the appliances by a person responsible for their safety.



Children should be supervised to ensure they do not play with the appliances.

The units are for indoor use only and must not be exposed to the elements of nature.

These units must not be positioned in an area that may be cleaned by a water jet. These units must not be cleaned by a water jet.

WARNING: For correct operation of this appliance it is essential to observe the manufacturer's instructions.

Precautions

The plumbing installation must be done in accordance with local Water Authority regulations and these Installation Instructions.

As the installer, it is your responsibility to supply (if necessary) and install all valves as required by local regulations and relevant standards.

Correct Use of JG Quick Connect Fittings

John Guest quick connect fittings and hoses are used in Zip products.

Note insertion and removal details for JG fittings using plastic tubing as seen in the adjacent diagram.

NB: Be sure to cut the tube squarely with a sharp knife or tube cutter. Shake out and remove any swarf or debris.

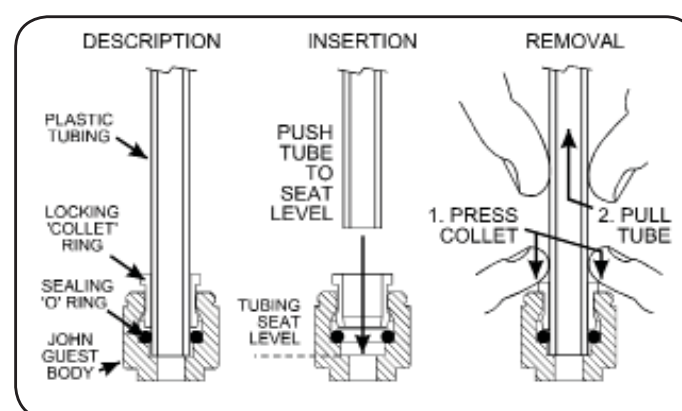

Installation Requirements

- Operating temperatures 5° C - 35° C.
- Water pressure 172 kPa - 700 kPa (0.172 MPa - 0.7 MPa)

It is the installers responsibility to ensure the installation complies with AS/NZS3500.1, AS/NZS3500.2, AS/NZS3500.4.1, AS/NZS3500.4.2 and local water authority regulations.

Installation Instructions

Installing the Filtration Unit

The filtration unit should be mounted in a convenient position in the cupboard, to allow for ready and easy access during filter changes.

Usually the side of the cupboard, near the door, is most suitable. However, the length of the tubes from filter to carafe tap and from water supply to filter need to be considered when selecting a suitable position to mount the filter head.

Using the two screws provided, screw the filter head to the inside of the cupboard, allowing 270 mm minimum clearance between the underside of the filtration head and any obstructions like shelves, etc.

Write the installation date on the filter cartridge. Fit the cartridge into the housing. The model you have may appear slightly different to that illustrated, however, operation and function is identical.

Align the tabs of the cartridge with the filter housing and insert it into the socket. Turn the cartridge a quarter turn to the right until it stops and locks into position.

Check that the direction of flow on the filter head is correct.

Installation Instructions

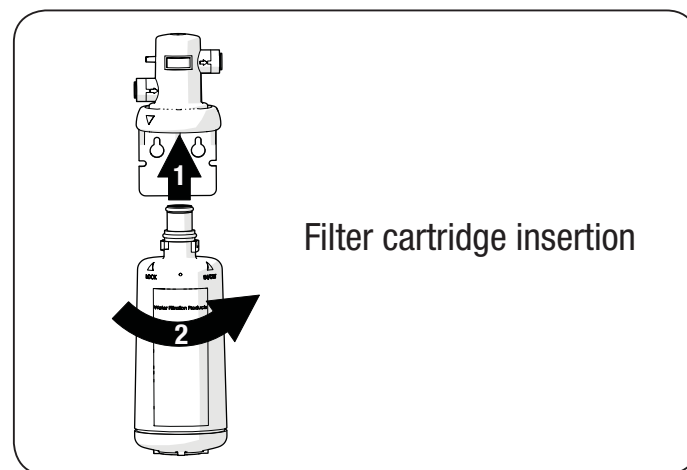
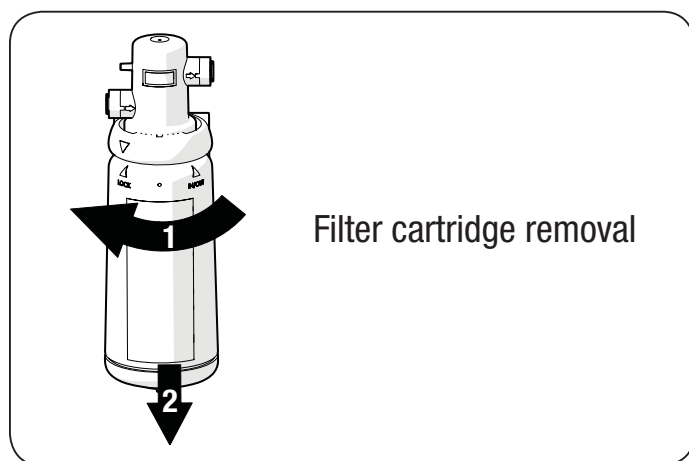

Installing the Filter Tap

Position the Filter Tap at the back of the sink where there is a 45 mm wide flat area within the draining areas of the sink. The recommended position is over one corner of the bowl. Make sure the selected position allows the spout to overhang the sink bowl.

The cutout size is 25 mm. Mark the centre of the new Filter Tap position on the sink with a centre punch. Drill out the centre of the hole to allow the screw of a sheet metal punch to pass through the sink. Use a 25 mm sheet metal punch to neatly cut the hole.

Remove the nut and washer from the base of the Filter Tap, and pass the tubing through the sink until the Filter Tap sits upright within the hole you just created in the sink surround.

Orientate the Filter Tap so that the activating lever is away from the sink bowl. Slide on the washer and nut from beneath the sink, and tighten the nut to secure the Filter Tap firmly into place.

Take care, when bending plastic tubing, to prevent it from kinking or crushing on a bend.

Do not connect the tubes in any other arrangement than that described here. The filter cartridge and the Filter Tap have directional flow connections that will not work if connected incorrectly. Incorrect installation will void any product warranty.

Note that the flow direction of the filter housing is indicated on the filter housing.

Measure and cut the tube from the Filter Tap to length so that it runs around the back of the cupboard to the outlet side of the filter housing. Use a tube cutter to cut the end off the tubing neat and square, so that there are no dabs or rough edges. Shake the tube vertically to allow any debris to fall out of the tube before inserting it into the filter head.

Push this end of the blue tube firmly into the John Guest socket on the outlet side of the filter head.

It must push in at least 10 mm. Test the connection by trying to pull the tube out. If it comes out, re-insert it so that it won't come out when pulled against.

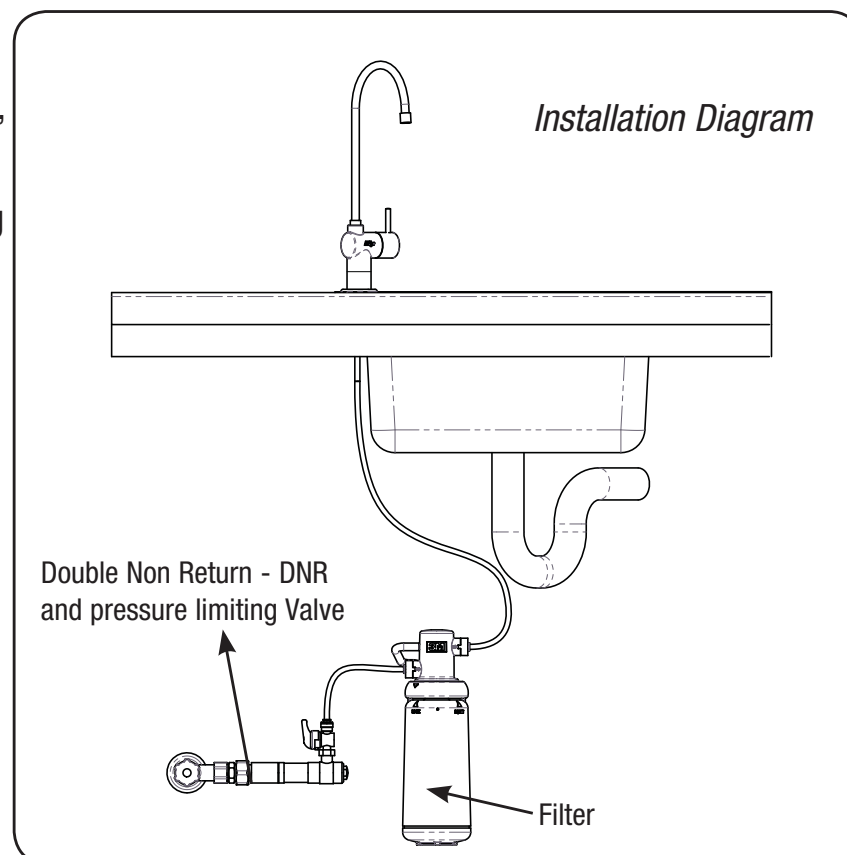

Installation Instructions

Installing the DNR Multifunction Valve

The DNR valve must be inserted into the tube between the main isolation valve and the filter cartridge. Ensure the flow is in the correct direction.

The DNR valve must be connected downstream of an accessible isolation tap. The 3/4" F- BSP threaded section on the inlet end of the DNR valve may be connected directly to an isolation tap.

NOTE: The centre of the 3/4" fitting may be removed with an 8mm allen key to allow for direct connection to a 1/2" BSP Tap. Remember to re-fit the strainer and sealing washer.

Alternatively, the DNR valve may be positioned so that it can be seated into a retaining clip screwed to the cupboard wall.

Take the one metre tube from the filter kit.

Measure and cut the tube from the DNR valve to length so that it runs around the back of the cupboard to the inlet side of the filter housing. Leaving a little extra slack in this line for the connection of the DNR valve.

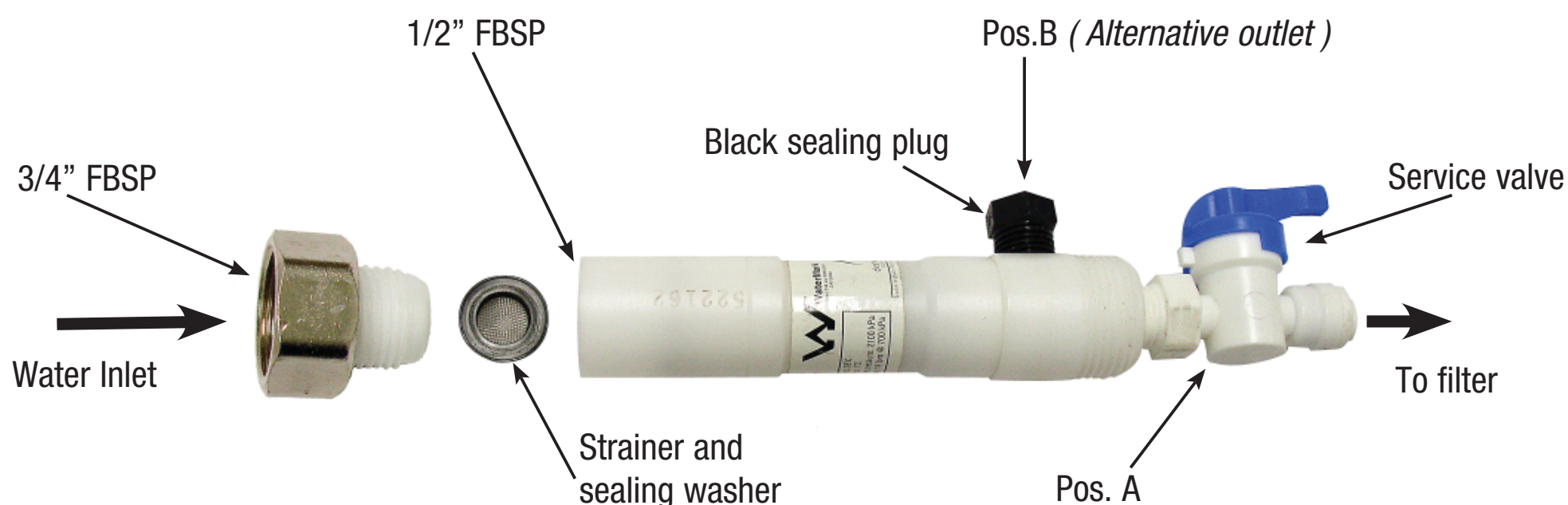
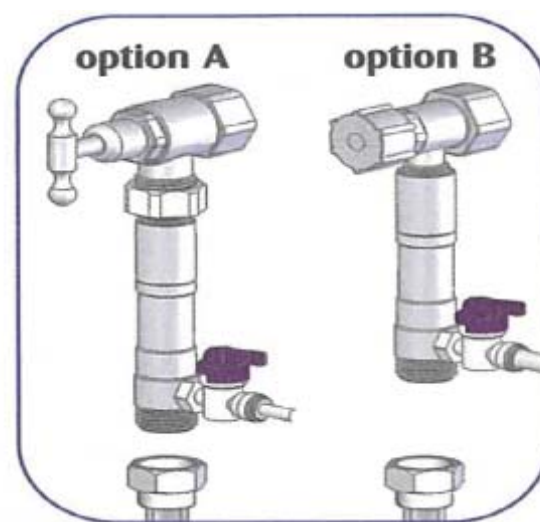

Insert the tube end into the (JG) fitting on the side of the DNR valve.

Insert the other end of tube into the (JG) fitting on the Inlet side of the filter head. Note the directional arrows on the body of the Valve. It must end up connected so that they point in the direction of the Flow. (see Installation Diagram on Pg 3.)

The valve may be positioned vertically or horizontally.

When mounted horizontally the service tap may be fitted to one of two outlet port positions i.e axially in line (Pos A) or at 90 degrees (Pos B). When changing the outlet position remember to refit the black sealing plug to the un-used port.

Filling the system

Turn 'on' the water supply. Check the connections for leaks. Repair any found.

The filter and tubing are full of air until purged, and the filter cartridge requires activation when first installed. Flip up the operating lever on the Zip Filter Tap for a minimum of five minutes until all of the air has been purged from the system, and the cartridge has time to become fully activated.

Every time the filter cartridge is replaced, repeat this procedure of a five minute flush to activate the new cartridge properly.

Installation Instructions

NOTE: When flushing the system, some black particles may be released into the water. This is normal. The water will become clear after the first few litres.

Complete the installation and leave these instructions with client.

Service

All service work must only be carried out by a suitably qualified and experienced service person.

Before calling for service, check the water supply is turned 'ON' and OK.

Call Zip in Australia on 1800-638-633 for assistance, service, spare parts, or enquiries.

Filter Replacement

Not changing cartridges when required may cause the water to become biologically unsafe.

Thoroughly flush the water through if the filter tap has not been used for more than 12 hours. For safe operation, the filter cartridge should be replaced at least every 6-12 months, or earlier if you notice a persistent reduction in water pressure from the Filter Tap, or an unpleasant taste or odour in the water.

Use only a Zip filter cartridge to match that of your Filter Tap. Replacement cartridges can be obtained through plumbing suppliers or directly from Zip.

When replacing your Zip filter cartridge, replacement instruction will be provided with your replacement cartridge kit.

Operating Procedures

Operating

You can obtain filtered water within the rated capacity for as long as you rotate the lever. In the upright position the tap is off, when the lever is rotated anticlockwise water will flow. Water will continue to flow until the lever is returned to the upright position.

Cleaning

Never use strong, corrosive or abrasive cleaning materials on the Zip Filter Tap. Wipe the outer surfaces clean with a sponge or a soft cloth using a mild soap and water.

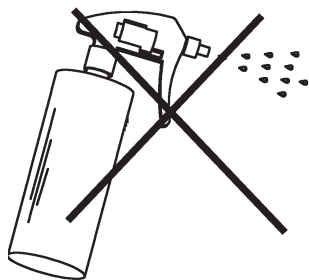

Troubleshooting

Problem	Cause	Remedy
No water at outlets	Water not connected	Connect and turn on water
Poor flow at outlet	Blocked filter	Replace filter

Performance Data Sheet

Use Replacement Cartridge 91289

The concentration of the indicated substances in water entering the system was reduced to a concentration less than or equal to the permissible limit for water leaving the system as specified in NSF/ANSI Standard 42 and NSF/ANSI Standard 53.

Capacity: 3,785 litres Contaminant Reduction Determined by NSF testing.

Test Conditions: pH7.5, Pressure: 415 kPa, Flow Rate: 1.9L/min

Substance Reduction	Average Influent	NSF/ANSI specified Challenge Concentration	Avg % Reduction	Average Product Water Concentration	NSF Max Permissible Product Water Concentration	Australian/ New Zealand (AS/NZS Standard 3497) Max Permissible Product Water Concentration	NSF Reduction Requirements	NSF Test Report
Chlorine Taste and Odor	2.0 mg/L	2.0 mg/L ±10%	97.3%	0.05 mg/L	N/A	5.0 mg/L	≥ 50%	J-00109688
Cyst*	140,000 cysts/L	Minimum 50,000 cysts/L	>99.99%	3 cyst/L	N/A	1 cyst/100 L	≥ 99.95%	J-00109693
Lead pH @6.5	0.150 mg/L	0.15 mg/L ± 10%	>99.3%	0.001 mg/L	0.010 mg/L	0.01 mg/L	N/A	J-00109691
Lead pH @8.5	0.150 mg/L	0.15 mg/L ± 10%	99.3%	0.001 mg/L	0.010 mg/L	0.01 mg/L	N/A	J-00109692

* Based on the use of Cryptosporidium parvum oocysts

Application Guidelines/ Water Supply Parameters	
Service Flow	1.9 lpm
Water Supply	Potable Water
Water Pressure	172 - 862 kPa
Water Temperature	4.4°C - 38°C



System tested and certified by NSF International against NSF/ANSI Standard 42 and Standard 53 for the reduction of substances as listed below according to Standard 42 and Standard 53.

It is essential that the manufacture's recommended installation, maintenance and filter replacement requirements be carried out for the product to perform as advertised. See installation Manual for details.

Note: While the testing was performed under standard laboratory conditions, actual performance may vary.

⚠ WARNING

To reduce the risk associated with ingestion of contaminants:

Do not use with water that is microbiologically unsafe or of unknown quality without adequate disinfection before and after the system. Systems certified for cyst reduction may be used on disinfected water that may contain filterable cysts.

EPA Establishment Number 070595-MEX-001

CAUTION

To reduce the risk associated with property damage due to water leakage:

- **Read and follow** Use Instructions before installation and use of this system.
- Installation and use **MUST** comply with all state and local plumbing codes.
- **Do not** install if water pressure exceeds 862 kPa. If your water pressure exceeds 551.68 kPa, you **must** install a pressure limiting valve. Contact a plumbing professional if you are uncertain how to check your water pressure.
- **Do not** install where water hammer conditions may occur. If water hammer conditions exist you must install a water hammer arrester. Contact a plumbing professional if you uncertain how to check for this condition.
- **Do not** install on hot water supply lines. The maximum operating water temperature of this filter system is 38°C.
- **Protect filter from freezing.** Drain filter when temperatures drop below 4.4°C.
- The disposable filter cartridge must be replaced every 12 months or at the specified service cycle, or sooner, if a noticeable reduction in flow rate occurs.



Notes

Contact Details

Head Office

Zip Heaters (Aust) Pty. Ltd.
ABN: 46 000 578 727
67 Allingham Street
Condell Park NSW 2200
Postal: Locked Bag 80
Bankstown 1885 Australia

Website: www.zipheaters.com
Facsimile: (02) 9796 3858
Telephone: (02) 9796 3100
Free Call: 1 800 638 633

As Zip policy is one of continuous product improvement, changes to specifications may be made without prior notice. Images in this booklet have been modified and may not be true representations of the finished goods.

The term "Zip" is a registered trade mark of Zip Heaters (Aust) Pty Ltd.

