

Contact Grill

User's manual

EN



SENCOR®

SBG 2050SS / SBG 2051BK
SBG 2052RD / SBG 3050SS
SBG 3051BK / SBG 3052RD

Prior to using this appliance, please read the user's manual thoroughly, even in cases where you have previously familiarised yourself with the operation of similar types of appliances. Only use the appliance in the manner described in this user manual. Keep this user's manual in a safe place where it can be easily retrieved for future use.

We recommend saving the original cardboard box, packaging material, purchase receipt and responsibility statement of the vendor and warranty card for at least the duration of the legal liability for unsatisfactory performance or quality. In the event of transportation, we recommend that you pack the appliance in the original box from the manufacturer.

EN-1

TABLE OF CONTENTS

IMPORTANT SAFETY INSTRUCTIONS	3
DESCRIPTION OF THE CONTACT GRILL	6
BEFORE FIRST USE	6
USING THE CONTACT GRILL	7
GRILLING WITH THE TOP PLATE TILTED DOWN	7
GRILLING ON AN OPEN GRILL	7
NON-STICK COATING ON THE GRILL PLATES	8
TIPS FOR GRILLING MEAT	9
MAINTENANCE AND CLEANING	9
STORAGE	10
TECHNICAL SPECIFICATIONS	10
INSTRUCTIONS AND INFORMATION REGARDING THE DISPOSAL OF USED PACKAGING MATERIALS	11
DISPOSAL OF USED ELECTRICAL AND ELECTRONIC EQUIPMENT	11

IMPORTANT SAFETY INSTRUCTIONS READ CAREFULLY AND STORE FOR FUTURE USE.

- This appliance may be used by children 8 years of age and older and by persons with physical or mental impairments or by inexperienced persons, if they are properly supervised or have been informed about how to use of the product in a safe manner and understand the potential dangers. Cleaning and maintenance performed by the user must not be performed by children unless they are older than 8 years of age and under supervision. Keep this appliance and the power cord out of reach of children that are younger than 8 years of age. Children must not play with the appliance.
- This appliance is designed for household use.
- Do not use the appliance in an industrial environment or outdoors or for purposes other than those for which it is intended.
- Connect the appliance only to a grounded power socket.
- Before connecting the appliance to a power socket, check that the technical details on its rating label match the voltage in the socket. Make sure the power cord does not hang over the edge of a table and that it is not touching a hot surface.



Attention:

This appliance is not designed to be controlled using a programmed device, external timer switch or remote control.

- Do not place the appliance on an electric or gas stove or in its vicinity, on the edge of a table or on an unstable surface. Only place the appliance on an even, dry and stable surface.
- Prior to putting the appliance into operation, make sure that the drip tray is properly located in the underside of the grill.
- Always set the angle of the bottom grill plate by folding the feet in or out before putting the appliance into operation. Do not set the angle of the bottom grill plate when the appliance is in operation or when it is hot. Otherwise, this could cause burns.

- When the appliance is in operation, it must be placed on a heat resistant surface and sufficient space for circulation must be provided above the appliance and on all its sides. Use the appliance at a sufficient distance from flammable materials such as curtains, kitchen towels, etc.
- When the appliance is in operation, the temperature of accessible surfaces may be higher. Accessible surfaces remain hot for some time after the appliance is turned off. Take care not to touch the hot outer stainless steel surface or the grill plates. Use the handle to tilt open the top grill plate.



This symbol on the product means: "**Attention:** Hot surface."

- Always disconnect the appliance from the power socket when you leave it without supervision or when not using it and before moving or cleaning it.
- Before moving, cleaning or handling it in any other way, allow the appliance to cool down. Before moving it, remove all food and liquids from the grill plates and empty out the drip tray.
- Be especially careful when handling the drip tray containing hot liquid.
- Clean the surface of the grill plates after each use according to the instructions in chapter Cleaning and maintenance.
- To prevent potential injury by electric shock, do not submerge any part of the appliance in water or any other liquid.
- Do not disconnect the appliance from the power socket by pulling on the power cord. This could damage the power cord or the power socket. Disconnect the cord from the power socket by gently pulling on the plug of the power cord.
- It is forbidden to use the appliance if it has a damaged power cord. If the power cord is damaged, have it replaced at a professional service centre.
- Do not use the appliance if it is damaged, not working correctly, if it has been dropped on the floor or submerged in water. In order to prevent a hazardous situation arising, do

Contact Grill

SBG 2050SS / SBG 2051BK / SBG 2052RD / SBG 3050SS / SBG 3051BK / SBG 3052RD

EN

not repair the appliance yourself or modify it in any way. Have all repairs or adjustments performed at an authorised service centre. By tampering with the appliance you risk voiding your legal rights arising from unsatisfactory performance or quality warranty.

Contact Grill

SBG 2050SS / SBG 2051BK / SBG 2052RD / SBG 3050SS / SBG 3051BK / SBG 3052RD

DESCRIPTION OF THE CONTACT GRILL

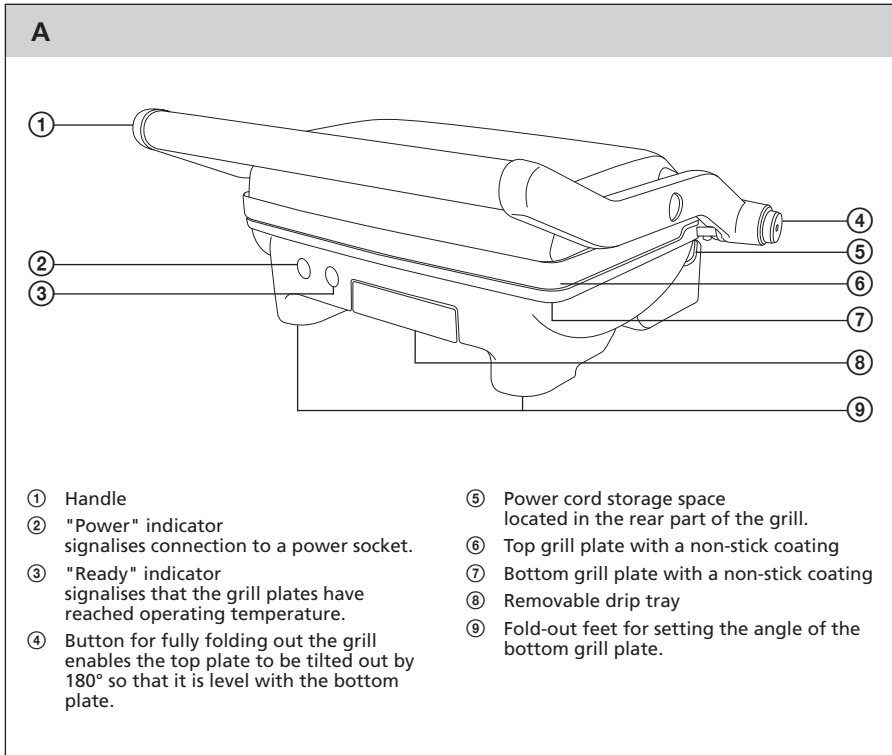

BEFORE FIRST USE

- Before first use, take the contact grill and its accessories out of the packaging material.
- Wipe the grill plates A⑥ and A⑦ with a dampened cloth and then wipe dry. Take the drip tray A⑧ out of the underside of the grill and wash it in warm water using a neutral kitchen detergent. Then rinse it under clean running water, dry it and put it back in its place.

USING THE CONTACT GRILL

- Locate the grill on a dry, even and stable surface from a heat resistant material.

GRILLING WITH THE TOP PLATE TILTED DOWN

- Before putting the grill into operation, set the angle of the bottom grill plate A⑦. Fold out the feet A⑨ to set the angle of the bottom grill plate A⑦ to enable better drainage of fat and juices into the drip tray A⑧. The bottom plate A⑦ will be tilted slightly backwards. If you leave the fold-out feet A⑨ folded in, the bottom plate A⑦ will be in a horizontal position.
- Check that the drip tray A⑧ is inserted in the underside of the grill and that it is pushed in all the way.
- Smear the grill plates A⑥ and A⑦ with a small amount of vegetable oil that is suitable for cooking.
- Fully wind out the power cord and connect the grill to a power socket. Connection to a power socket is signalled by the "Power" indicator A② being lit.
- Allow the grill plates A⑥ and A⑦ to preheat. To speed up the preheating process, fold the top plate A⑥ down on to the bottom plate A⑦. Upon reaching the operating temperature, the "Ready" indicator A③ will be lit.
- Tilt open the top plate A⑥ so that it is in a vertical position. Use the handle A① to tilt out the plate A⑥. Place the food that you wish to grill (meat, hamburgers, fish, vegetables, etc.) or bake (paninis or sandwiches) on to the bottom plate A⑦.
- Use the handle A① to tilt down the top plate A⑥. The grill is designed in such a way that the distance between the grill plates A⑥ and A⑦ adjusts to the food that is placed in between them. When grilling, regularly inspect the state of the food and the capacity of the drip tray A⑧.



Note:

You may see a small amount of smoke when you turn on the grill for the first time. This is caused by certain components being heated up for the first time. This need not disturb you.

During operation, the "Ready" indicator A③ will intermittently turn on and off. This signals that the operating temperature is being maintained.



Attention:

Be especially careful when handling the drip tray A⑧ containing hot liquid.

- When the food is cooked, tilt open the top plate A⑥ and use a plastic or wooden spatula to take it off the grill plate A⑦. Do not use metal tongs or metal spatulas, knives or other sharp metal kitchen utensils. This could cause damage to the non-stick coating of the grill plate A⑦.
- When you have finished, disconnect the grill from the power socket and allow it to cool down. Then clean it out according to the instructions in chapter Cleaning and maintenance.

GRILLING ON AN OPEN GRILL

- The unique design of the grill enables both grilling surfaces A⑥ and A⑦ to be used at the same time. To fully tilt open the grill, it is necessary to disengage the top plate lock A⑥ by pressing button A④. Hold down button A④ while tilting open the top plate A⑥ so that the handle A① leans against the workbench of the table and the top grill plate A⑥ is level with the bottom grill plate A⑦, see fig. B.

Contact Grill

SBG 2050SS / SBG 2051BK / SBG 2052RD / SBG 3050SS / SBG 3051BK / SBG 3052RD

B

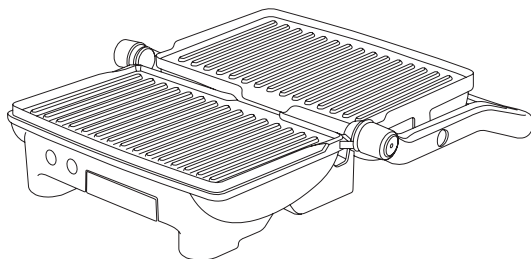

Note:

The lock will be re-engaged when the top plate A⑥ is tilted down to the vertical position or when tilted on to the bottom plate A⑦. This is signalled by button A④ sliding out, which is accompanied by an audible click.

- Set the angle of the bottom grill plate A⑦. Fold out the feet A⑨ to set the angle of the bottom grill plate A⑦ to enable better drainage of fat and juices into the drip tray A⑧. The bottom plate A⑦ will be tilted slightly backwards. If you leave the fold-out feet A⑨ folded in, the bottom plate A⑦ will be in a horizontal position.
- Check that the drip tray A⑧ is correctly inserted in the underside of the grill. To ensure that liquids are drained from the top plate A⑥ into the drip tray A⑧, the drip tray A⑧ must be pushed all the way in to the underside of the grill.
- Smear the grill plates A⑥ and A⑦ with a small amount of vegetable oil that is suitable for cooking.
- Fully wind out the power cord and connect the grill to a power socket. Connection to a power socket is signalled by the "Power" indicator A② being lit.
- Allow the grill plates A⑥ and A⑦ to preheat. Upon reaching the operating temperature, the "Ready" indicator A③ will be lit. The grill is now ready for use
- Place meat, vegetables or other food suitable for grilling on to the grill plates A⑥ and A⑦. When grilling food, flip it over as required and regularly check the capacity of the drip tray A⑧.



Note:

You may see a small amount of smoke when you turn on the grill for the first time. This is caused by certain components being heated up for the first time. This need not disturb you. During operation, the "Ready" indicator A③ will intermittently turn on and off. This signals that the operating temperature is being maintained.



Attention:

Be especially careful when handling the drip tray A⑧ containing hot liquid.

- When the food is cooked, use a plastic or wooden spatula to remove it from the grill plates A⑥ and A⑦. Do not use metal tongs or metal spatulas, knives or other sharp metal kitchen utensils. This could cause damage to the non-stick coating of the grill plates A⑥ and A⑦.
- When you have finished, disconnect the grill from the power socket and allow it to cool down. Then clean it out according to the instructions in chapter Cleaning and maintenance.

NON-STICK COATING ON THE GRILL PLATES

- The grill plates A⑥ and A⑦ of your contact grill have a special non-stick surface coating. This coating enables you to prepare healthier meals while using a minimum amount of fat or oil.
- Do not use sharp or metal kitchen utensils and do not cut the food directly on the grill plate. The manufacturer takes no responsibility for damage to the surface caused by incorrect use.
- Any discolouration of the surface of the grill plates A⑥ and A⑦ affects only appearance, not functionality.

TIPS FOR GRILLING MEAT

- We do not recommend using the contact grill for grilling meat with thick bones, such as bone-in pork chops.
- We recommend that you season meat with salt or other spices only after it is grilled. When you salt meat before grilling, it may dry out.
- Before grilling marinated meat, pat it down with paper towels to remove excess marinade. Some marinades have a high sugar content, which may burn on to the grill plates.
- To avoid juices escaping, do not puncture the meat with a knife or fork while grilling it. Otherwise the meat will be tough and dry.
- Do not dry out the meat by grilling it for too long.
- Always make sure that chicken meat is thoroughly cooked.
- You do not have to prick pre-cooked hot dogs before grilling them.

MAINTENANCE AND CLEANING

- Before cleaning the contact grill, always disconnect it from the power socket and allow it to cool down.

Cleaning the grill plates

- Clean the surface of the grill plates A⑥ and A⑦ after every use.
- For cleaning, use a dampened, soft cloth. If charred food remains, e.g. from marinated meat, stick to the surface of the grill plates A⑥ and A⑦, apply a weak solution of neutral kitchen detergent and water to these areas. After applying this solution, clean the grill plates A⑥ and A⑦ using a clean dampened textile and then wipe dry.



Tip:

It will be easier to clean the grill plates A⑥ and A⑦ while they are still lukewarm.

Cleaning the drip tray

- After each use, take the drip tray A⑧ out and empty it. Wash it in warm water with an addition of neutral kitchen detergent. Then thoroughly rinse it under clean running water, dry it and place it back into the underside of the grill.



Attention:

Be especially careful when handling the drip tray A⑧ containing hot liquid.

Cleaning the outer surface

- Use a dampened textile to clean the outer surface of the grill. Then wipe everything so that it is thoroughly dry.

Contact Grill

SBG 2050SS / SBG 2051BK / SBG 2052RD / SBG 3050SS / SBG 3051BK / SBG 3052RD

- Do not use steel wool, abrasive cleaning products, petrol or solvents to clean the contact grill. To prevent potential injury by electric shock, do not submerge any part of the contact grill in water or any other liquid.

STORAGE

- Once the plates of the contact grill have cooled down, tilt the top plate A⑥ down on to the bottom plate A⑦ and wind up the power cord into the area in the rear part of the grill A⑤. Store the grill in a clean, dry place that is out of reach of children.

TECHNICAL SPECIFICATIONS

SBG 2050SS / SBG 2051BK / SBG 2052RD

Rated voltage	220–240 V
Rated frequency	50/60 Hz
Rated power.	970–1080 W

SBG 3050SS / SBG 3051BK / SBG 3052RD

Rated voltage	220–240 V
Rated frequency	50/60 Hz
Rated power.	1650–1960 W

We reserve the right to change text and technical specifications.

INSTRUCTIONS AND INFORMATION REGARDING THE DISPOSAL OF USED PACKAGING MATERIALS

Dispose of used packaging material at a site designated for waste in your municipality.

DISPOSAL OF USED ELECTRICAL AND ELECTRONIC EQUIPMENT



This symbol on products or original documents means that used electric or electronic products must not be added to ordinary municipal waste. For proper disposal, renewal and recycling hand over these appliances to determined collection points. Alternatively, in some European Union states or other European countries you may return your appliances to the local retailer when buying an equivalent new appliance. Correct disposal of this product helps save valuable natural resources and prevents potential negative effects on the environment and human health, which could result from improper waste disposal. Ask your local authorities or collection facility for more details. In accordance with national regulations penalties may be imposed for the incorrect disposal of this type of waste.

For business entities in European Union states

If you want to dispose of electric or electronic appliances, ask your retailer or supplier for the necessary information.

Disposal in other countries outside the European Union.

This symbol is valid in the European Union. If you wish to dispose of this product, request the necessary information about the correct disposal method from the local council or from your retailer.



This appliance meets all the basic requirements of EU directives related to it.

Contact Grill

SBG 2050SS / SBG 2051BK / SBG 2052RD / SBG 3050SS / SBG 3051BK / SBG 3052RD