

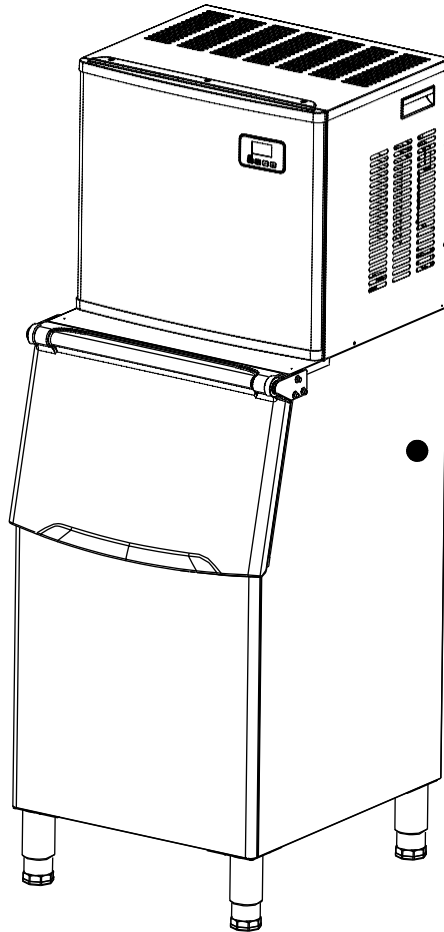

Commercial ice machine



Instruction Manual

Model: CIM-315

Thank you for purchasing our product!

Before returning to retailer, if you are having trouble with your unit, for assembly assistance, missing or damaged parts.

Please contact customer service Phone: 718-576-6342

Email: support@koolmore.com

We are here to help.

Thank you!

When using electrical appliances, basic safety precautions should be followed to Reduce the risk of fire, electric shock, and injury to persons or property. Read all Instructions before using any appliance.

When the unit is received please wait 24 hours before plugging it in to let the refrigerant settle in case it has been turned during transit

Use this appliance only for its intended purpose as described in this owner's manual.

This ice-maker must be properly installed in accordance with the installation instructions before it is Used.

This unit must be positioned so that the plug is accessible. Do not run cord over carpeting or other heat Insulators

Do not cover the cord. Keep cord away from traffic areas, and do not submerge in water. No other appliance should be plugged into the same outlet, and be sure that the plug is fully inserted into The receptacle.

We do not recommend the use of extension cord as it may overheat and cause a risk of fire. If you must

Disconnect the mains plug from the supply socket when not in use for a long term, where supply Connection is via mains plug.

Remove power plug or disconnect from the mains before cleaning or servicing the appliance.

NOTE: If

For any reason this product requires service, we strongly recommend that a certified technician perform the service.

Never unplug you unit by pulling on the power cord. Always grasp the plug firmly and pull straight out from the outlet.

Do not use your unit outdoors. Keep the unit away from direct sunlight and make sure that there is at least 6 inches of space between the back of your unit and wall and keep the front free. Keep ventilation opening in the appliance enclosure or in the built-in structure, clear of obstruction.

Do not tip over the unit, which will cause abnormal noisy and make the ice-cube size abnormal. And Seriously, it may cause water leakage from the unit.

If the unit is brought in from outside in the winter season, give it a few hours to warm up to room Temperature before plugging it in.

Do not use other liquid to make the ice-cube other than water.

Do not clean your ice maker with flammable fluids. The fumes can create a fire hazard or explosion.

INTRODUCTION	2
PREPARATION BEFORE USE	
UNPACKING YOUR MACHINE	4
HOW TO CLEAN THE MACHINE	4
CONNECTING TO A WATER LINE.....	5
OPERATING YOUR UNIT.	6
SCHEMATIC DIAGRAM.....	7
TROUBLESHOOTING.....	10
WARRANTY.....	11

The characteristics of this product

- Stable and reliable performance with microcomputer control chip
- Higher efficiency and more energy saving by using high efficient heat exchanger & dc fan
- Transparent ice, hard to melt.
- Force de-icing when working.
- Timing boot regularly shutdown function
- Ambient temperature display, countdown when working
- Easy cleaning and installation.

Please note

1. Please ensure the unit is properly grounded
2. Please unplug the unit (turn off the power switch) when not in use for a long period of time
3. Please clean the tank and water tank regularly It is recommended to clean the tank every three days.

INTRODUCTION

Main machine assembly

1. Screw the four adjustable feet of the attachment into the ice cabinet. (Notes: The feet should not be loose.)
2. Put the ice cabinet on the floor and place the bin on the ice cabinet. (Note; it should be firmly in place after completing the installation)

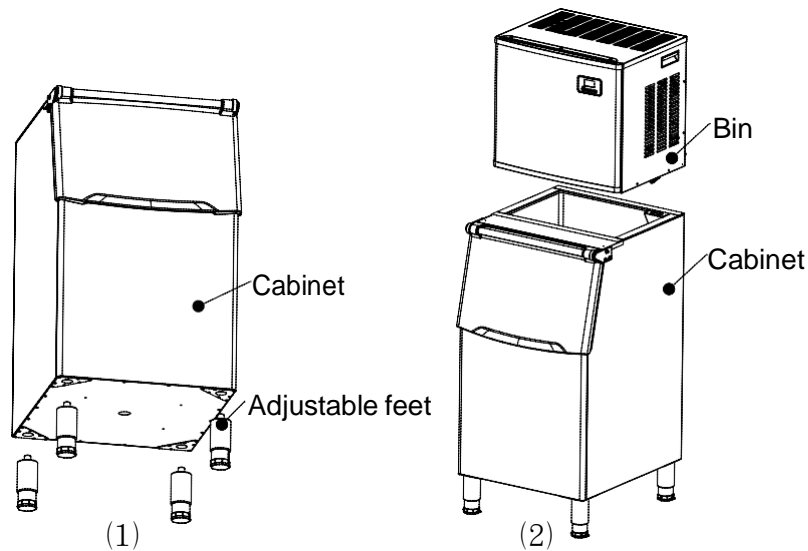

I. ABOUT THE MACHINE

1. Vents on the top: ensure smooth air flow, hot air can escape when making ice.
2. Controller
3. Front panel
4. Outlet tube connection: water inlet
5. Power cord
6. Ice gate:
7. Ice machine liner:
8. Drain: Remove the white drain pipe from the packaging
9. Adjustable feet

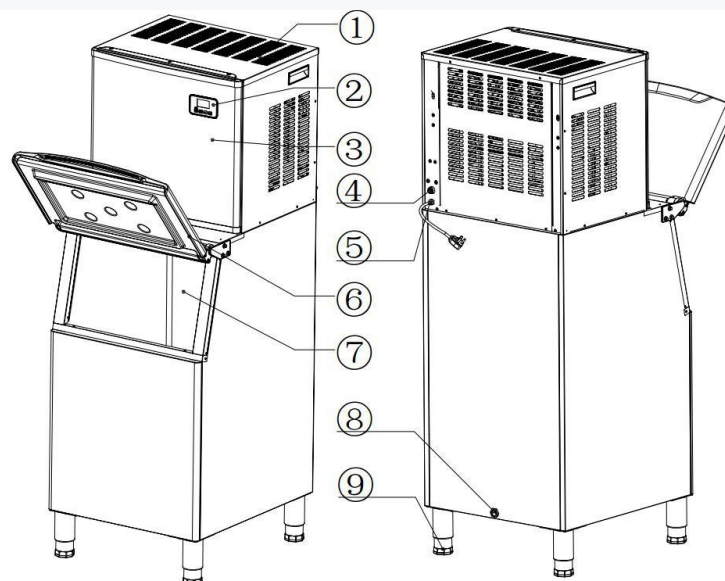

Spare parts for host : 1/4 transmitted to 1/3 pipe connector 、 L type 1/3 fast-inserting joint

transmitted to 1/3 latch、 dia 9.52mm white inlet pipe。

Spare parts for ice cabinet: white water pipe, ice scoop, adjustable feet 4pcs

II.Host

distributive pipe:

Water flows through small holes when making ice.

B. Evaporator:

C. Ice full checkerboard Stop working when ice full or check the process of deicing finished

D. water supply part:

E. level switch:

F. pump for water circulation:

G. drain plug for water tank:

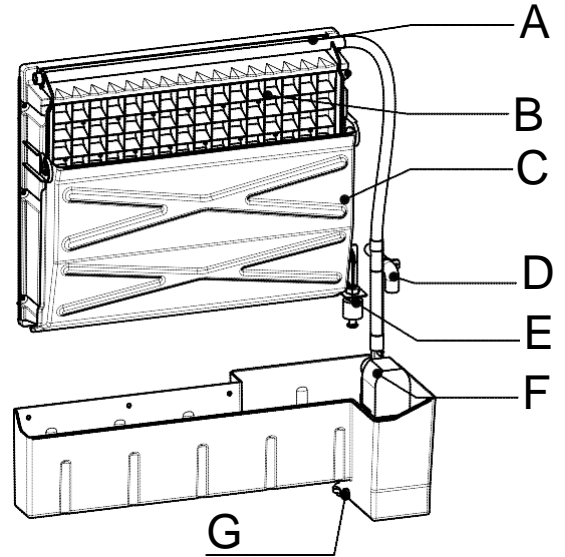

III. Operation panel

A. "Timed cleaning" button:

Press the button, and the machine will set the timing; while pressing for more than 5 seconds, the machine will enter the automatic cleaning program.

B. "On / Off" button:

Press "on" or "off" button. The cleaning and timing functions will be cancelled at the same time; If the machine is making ice, press the key for more than 5 seconds, and it will be forced to enter the de-icing status.

When the machine automatically enters the cleaning status

After it is turned on, press the "timed cleaning" button to stop the cleaning status and start ice making.

C. LCD display area

1. Ambient temperature display and ice-making time countdown display, when M is displayed, it is

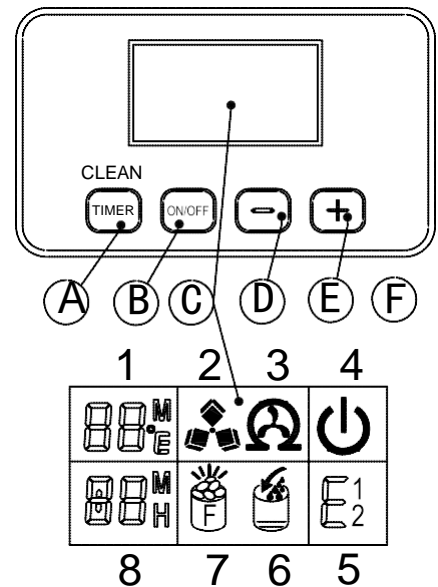

- The ice-making time countdown display; when C is displayed, it is the ambient temperature display.
2. The ice making and de-icing symbols are displayed. The ice is being made when the symbol is rotating, and it is being de-iced when the symbol is flashing.
 3. Automatic cleaning symbol displays.
 4. On / off symbol display.
 5. Error code E1 means is the ambient temperature sensor is damaged, E2 Error means ice making is malfunctioning or there is a refrigerant leakage.
 6. The machine's water intake and water shortage are displayed. The blinking arrow indicates that water is entering the machine. The whole symbol is on to indicate that the machine is short of water.
 7. The machine is full of ice. The machine will continue to make ice after removing the ice cubes.
 8. Setting display. "H" means "hours". If it displayed on the LCD, it means countdown time for ON or OFF regular timing; while "M" displayed, it is for ice making time setting.

D and E, "-", "+" buttons:

Adjust the length of the ice making time, the initial value is 0, you can adjust it by pressing the + and – buttons this will increase/decrees the time by one minute;

Adjust the length of the timer, the default is 1, you can adjust it by pressing the + and – buttons this will increase/decrees the time by one hour.

F. "Light" button (not all models have this function):

Press the button, the host bottom light will turn on, and press it again, the light will turn off. If the light does not turn off for a long time, the light will turn off automatically.

Unpacking the machine

Remove the unit from the carton and remove all packing foam, bags and tape. Please check ensure that you revived the flowing parts and accessories.

1 White water inlet pipe, 1 1/4' to 1/3' quick connection,

1 L-type 1/3'quick connection to 1/3' plug-in

1 Ice scoop, 1 white drain pipe, and 4 adjustable feet. Please contact us immediately if any parts are missing

2. The power socket must be reliably grounded, and a separate plug is required to supply power to the machine.

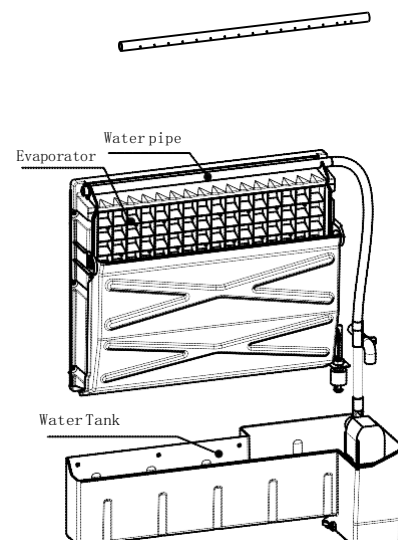

3. Install 4 adjustable feet on the unit, and then place the bin on the cabinet. The machine needs to be placed in an environment of good ventilation and relatively low ambient temperature. It should be placed horizontally, and the distance between the air outlet and the barrier should be at least 7.5 Inch, and between the two sides and the barrier should be no less than 2 In.

The new machine must be thoroughly cleaned before use

1. Open the machine and remove the ice gate.
2. Clean the unit with neutral detergent, warm water and soft cloth.
Repeatedly clean the inner tank of the cabinet until the inner tank is clean. Please discard the first batch ice cubes.
4. Wash the machine with water or wipe with a damp cloth and dry with a dry cloth.

During the use of the machine, regularly clean and maintain the ice machine.

1. Repeat the above steps to clean the inner tank of the cabinet.
2. Please pay attention to the cleaning of water distribution pipe in the upper part of the evaporator.

If compressor and pump perform normally but the water flow through the water pipe (a total of 17 small holes) is too small or no water is spraying. Please remove the water distribution pipe and clean it. Clean each small hole in the water distribution pipe as shown in the figure, in order to keep all the holes clear and remove blockage. After completion, restore the water distribution pipe (Power off before cleaning, and then remove the front panel).

3. Please clean the evaporator inner wall and the water tank regularly, which will be conducive to the normal pumping of the machine pump. The cleaning cycle is related to the water quality.
4. If there is ice on the evaporator with strong adhesion, do not forcedly pry with objects. Please press the "on / off" button for more than 5 seconds to forced ice process during ice making. After all the ice is over, turn off the power and clean the machine.

Remove the top 3 screws first,
then move the front panel up.

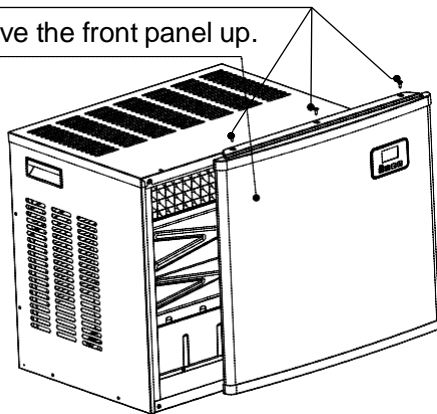

Water connection

1. The connection between the water pipe and the machine: tear off the external water supply pipe interface tape as shown in Figure A on the back of the machine, and remove the blue color on the external water supply pipe interface and the "L-type 3/4 quick connect to 3/4 plug-in" in the attachment. The color "buckles" are removed separately, and then insert the "L-type 3/4 quick-connect to 3/4 plug-in" into the "outer water supply pipe interface" of the host machine to the innermost, and then insert the white water pipe in the attachment to the innermost, and finally snap the two buckles into the two interfaces to complete the connection between the water pipe and the machine.

Note: To remove the water pipe, first remove the buckle on the interface, push the water pipe inwards, and then use the fingers of the other hand to press the knife ring that fixes the water pipe, and then remove the water pipe.

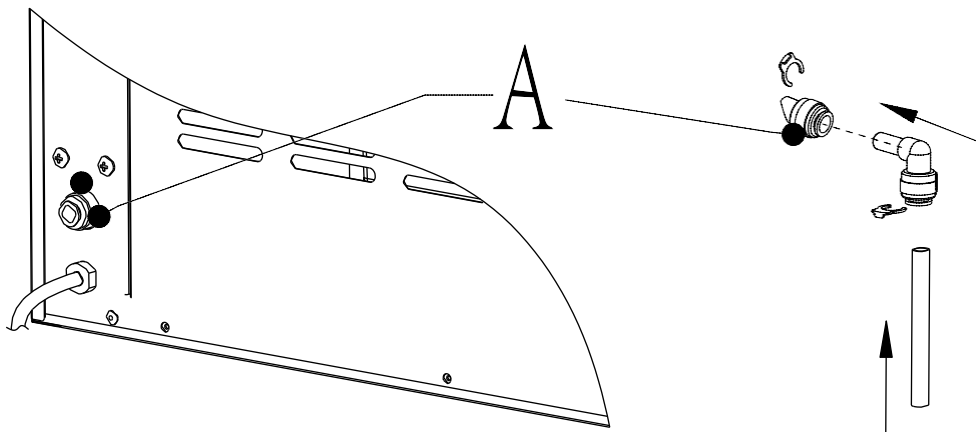

Drain pipe connection: screw the white drain pipe assembly in the attachment into the drain of the cabinet, and connect the other end of the white drain pipe assembly to the sewer pipe.

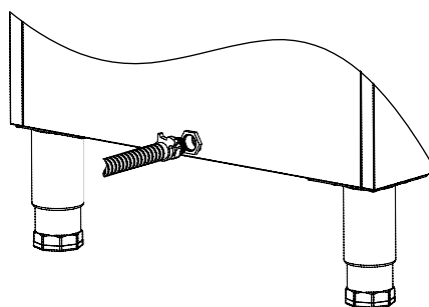

1. The host is connected to the drain of the cabinet: when the host is placed on the cabinet, the drain (position A shown below) of the host needs to be connected with the hole of the drain baffle on the cabinet (lower Picture B position).

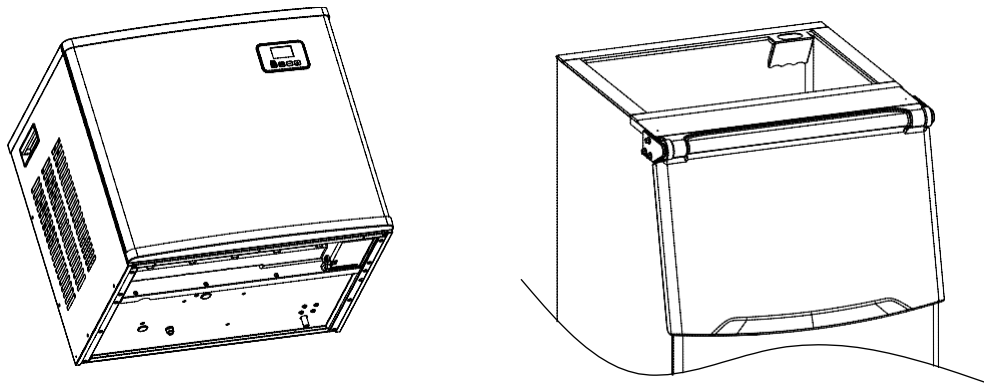

4. Connection of water pipe and faucet: connect the 4-point to 3-pipe conversion head in the accessory to the valve (thread), after removing the buckle of the adapter, insert the white water pipe and reset the buckle to complete the connection between the water pipe and the faucet (the faucet is provided by the user), the external water source needs to reach 0.04 ~ 0.5MPa. If the water pressure exceeds 0.8MPa, a pressure reducing valve needs to be added (only for external faucet).

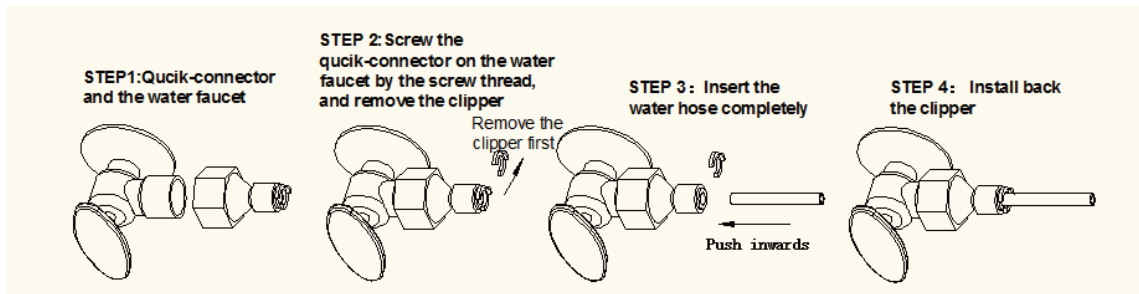

How to operate



Ice making operation

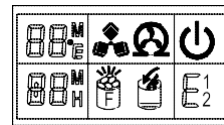

Operation and its symbol on LCD

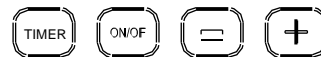

CLEAN





1. Turn on the ice machine: plug the power, the symbol of power  will flash, press "ON"/"OFF", the out tube can input the water from water tank through magnetic valve. The Machine will start a self-clean after when ready. The symbol  will revolve on the screen. It Will drain the water after 50s cleaning, add water after 50s draining, and clean again as long as necessary. Press "Timing/Cleaning", it will cancel the cleaning cycle.

2. After cleaning it will begin to make ice, the symbol  will be shown on the screen the symbol  will rotate; The ambient temperature will be displayed on the upper left. While "25°C" Means current temperature. After working for several minutes, there will be a flashed figure "10M" on the ambient temperature area which means ice making countdown of 10 minutes.

3. After every cycle of ice making, there is a process of de-icing. When the ice making symbol

 appears, the outlet tube can receive the water through the magnetic valve. The arrow of the symbol

 will be displayed when adding water. After it has enough water,  it will darken and begin the

the next cycle. If it does not have enough water, the symbol  will appear and the machine will stop working. It needs to re-operate the machine after insufficient water, or it will automatically be starting up after 15s.

Note: Each ice making cycle is about 11-20 minutes, and the ice making time varies depending on the ambient temperature and the temperature of the added water. Especially for the first time, since the water temperature in the water tank is higher, the ice making time will be longer. But the ice making cycle will not exceed 30 minutes.

3. Ice thickness adjustment: When the thickness of the ice cube is not ideal, it can be adjusted by the "+" and "-" keys on the operation panel; the number at the lower left of the display is the ice making time setting, the default is "0" ", Press the "+" button once to increase the ice making time by one minute, the corresponding ice cubes will be thicker; press the "-" button once to reduce the ice making time by one minute, the corresponding ice cubes will be thinner. After the machine is powered on again, it returns to the default setting "0".

Note: The currently set time only changes the time of the next and subsequent ice making cycles. Poor water quality will cause the ice cubes to turn white and the transparency will decrease.

4. When the ice full symbol lights up, the ice machine will stop working, and starts working again after removing the ice cubes.

5. Ice-making shutdown: During the ice-making process, press the "On / Off" button on the operation panel, the machine will shut down and enter the standby mode;

If in the ice-making process, press and hold the "On / Off" button for more than 5S, the machine will enter the de-icing process, this function can help remove the ice cubes on the ice tray. Press the "On / Off" button again, the machine will shut down.

Automatic cleaning operation

Automatic self-cleaning program, the default cleaning is twice (about 5 minutes). Plug the machine connected to the pipeline into the power plug, press and hold the "timed cleaning" button on the control panel for more than 5 seconds, start to enter the automatic cleaning function, the display symbol  on the display dynamically rotates, and after 50 seconds of cleaning, automatic drainage starts, Drainage is completed after 50 seconds, and then add water automatically, after the standard water level, it will automatically wash again.

Cancel automatic cleaning: It takes about 5 minutes to complete a self-cleaning procedure. When the program ends, the system will automatically shut down. In addition, you can also press the "On / Off" button on the control panel. Forcibly cancel the self-cleaning procedure.

3. Timing start-up and timing shutdown function operation:

Timing setting: Timing setting range: 1-24 hours

Timed shutdown: the machine can be set to shut down regularly during the ice making process.

Timed start: when the machine is in standby, it can be set to start regularly.

How to set the timing

Press the "timing" key on the operation panel, the timing time "1H" appears at the lower left of the display, and then press the "+" key to adjust the timing time you need, each time you press, the time increases by 1 hour; press "-" to reduce the timing time. In the process of time adjustment, the

"H" in the lower corner of the number is flashing. When it becomes steady after 5 seconds, the setting is completed. 5H is displayed in standby mode, indicating that the machine will automatically turn on after 5 hours; 5H in ice making mode, indicating that the machine will automatically shut down after 5 hours, "H" in the display indicates that the machine currently has a timer function, and the number will become smaller and smaller until it becomes 0, the timing ends, and the machine enters the mode you need.

How to cancel timing

When the machine has timing (the display has XX H), press the "timing" key, the numbers and "H" on the screen will go out, and the timing will be cancelled.

You can also directly press the "On / Off" button on the operation panel to force the timer power-on function to be turned off, and also turn off the ice-making function.

When the machine has timing settings, the display area in the lower left corner will display the timing time and ice making time, and the display content will be switched to every 5S.

TOUBLESHOOTING

touble	reason	solution
“ ” appear	Insufficient water	Low water inputting pressure or pipe blockage—add pressure or clean the pipe
	The ball on Level switch locked	Cleaning the water tank and level switch
	Water isn't remaining in the unit	Place the machine in horizontal position
	Water leaves the drain	Put the drain plug and do adjustment
Pump working but no water flow out through the distributive pipe	Pipe blockage	Clean the hole
Bad ice transparency	Water is not good	Change water, filter and soften the incoming water
Ice irregular	Poor water quality or dirty water tank	Clean the water tank and change the water
	Hole on distributive pipe blocked	Clean distributive pipe
Ice is too thin	High ambient temperature	Move the machine to a cool place or add ice making time
	unventilated	Keep the surrounding of machine more than 8 Inches
Ice is too thick	Lower the ambient temperature	Reduce the ice making time
“ICE FULL” showed	Ice is full	Move the ice out of the tank
	Ice blocks the detecting board	Wait for the ice to melt
Ice making process is normal but no ice	High ambient temperature or high water temperature	Move the machine to a place lower than 32°C or add cool water
	Refrigerant leak	Call an authorized technician
	Refrigeration blocked	Call an authorized technician

Troubleshooting display

- A. Ambient temperature sensor is broken: E1.
- B. No ice or refrigerant leak: E2.
- C. Magnetic valve disconnected, the indicator of ice full displayed. After connecting, the indicator darkens.
- D. Press ON/OFF for more than 5s, and the machine starts to de-icing. After it finishes, the process of ice making proceeds.