

CHEF'S **COMBI**TM

MAINTENANCE MANUAL



Table of contents

1. THE ESSENTIALS	5
1.1 REPLACING ELECTRONIC BOARDS	5
1.2 REPLACING THE HUMIDITY SENSOR	6
1.3 REPLACING THE FOOD CORE TEMPERATURE PROBE	7
1.4 REPLACING THE TEMPERATURE PROBE OF ELECTRIC STEAM GENERATOR	7
1.5 REPLACING THE TEMPERATURE PROBE OF GAS STEAM GENERATOR	8
1.6 REPLACING THE AMBIANT TEMPERATURE PROBE	8
2. SPECIFIC TOOLS	9
3. SETTINGS	10
3.1 PIN CODES	10
3.2 SOFTWARE INITIALIZATION	10
3.3 SETTING THE SOFTWARE LANGUAGE	10
3.4 WATER TREATMENT CAPACITY	11
3.5 CHECKING SOFTWARE VERSION	11
3.6 UPDATING THE SOFTWARE	11
3.7 PROBES CALIBRATION	13
3.8 PARAMETERS SCREEN	14
4. PREVENTIVE MAINTENANCE	16
4.1 LIST OF ACTIONS	16
4.2 SETTING MAINTENANCE INTERVENTION FREQUENCY, DAILY USAGE RATE	18
5. TROUBLESHOOTING	20
5.1 TROUBLESHOOTING METHOD	20
5.2 ERRORS MESSAGES	20
5.3 MAINTENANCE SCREENS	29
5.4 COMMUNICATIONS LEDS	32
5.5 OTHER SYMPTOMS	36
5.6 FLOWCHART	38
5.7 RESET	42
6. ELECTRIC DIAGRAMS	44
6.1 DIAGRAMS	44
6.2 6 AND 10 LEVEL CAVITY VENTILATION	50
6.3 GREASE COLLECTION OPTION	51
6.4 PARTS LIST	52
7. HYDRAULIC DIAGRAM	54
7.1 6 AND 10 LEVEL OVENS	54
8. GAS DIAGRAM	56
8.1 6 AND 10 LEVEL OVENS	56
9. ACCESS TO COMPONENTS	57
9.1 LOCATION OF TECHNICAL COMPONENTS	57
9.2 ACCESS TO COMPONENTS	57
10. COMPONENTS	60
10.1 ELECTRONIC BOARDS	60
10.2 ELECTRIC BOARDS	64
10.3 OTHER COMPONENTS	65
11. RECOMMENDED AND EMERGENCY SPARE PARTS	67
12. COMBUSTION GAS ANALYSIS PROCEDURE	69
13. CONTROL OF THE ELECTRODES (GAS BURNER)	71
14. CHANGING THE EQUIPMENT FROM ONE GAS TO ANOTHER	72
14.1 GAS FLOW RATES AND POWERS	72

14.2	CHART OF GAS INJECTORS.....	72
14.3	CHANGEOVER FROM ONE GAS TO ANOTHER:	72
14.4	CHANGING/ADJUSTING GAS VALVE	74
15.	CONVERSION TABLES	75
15.1	PT100 PROBE.....	75
15.2	CELSIUS / FAHRENHEIT TEMPERATURE.....	76
15.3	WATER HARDNESS.....	76
15.4	PRESSURE	76



1. THE ESSENTIALS



1.1 REPLACING ELECTRONIC BOARDS

When replacing the electronic boards (Aag gas board, Ahu humidity board, Ar Main board or Ac encoder board), no additional updates or settings are required. Simply follow these steps:

- » Remove the faulty board.
- » Install new board in its place.
- » Make necessary connections.
 - ⓘ On start-up, the system will automatically set up the new board

However, to replace the Ai interface board, it is essential to recover the SD card from the faulty board. This makes it easier to set parameters and recover customer settings and data. Follow these steps:

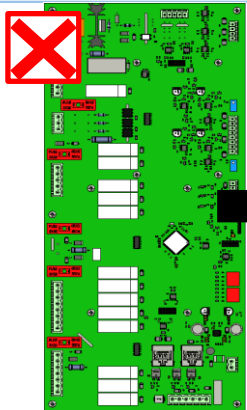
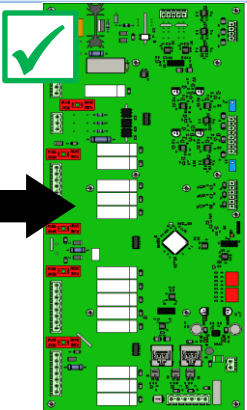
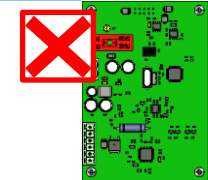
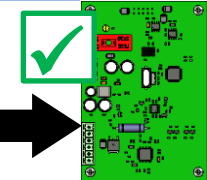
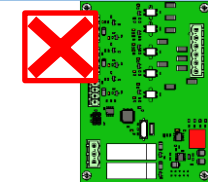
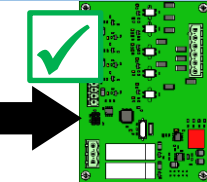
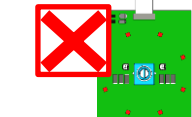
- » Remove faulty interface board.
- » Remove SD card from the interface board.
- » Insert this SD card into interface board.
- » Install new interface board.
- » Make necessary connections.
 - ⓘ When it starts up, the system will ask you to confirm that the parameters have been copied and will automatically configure the board.

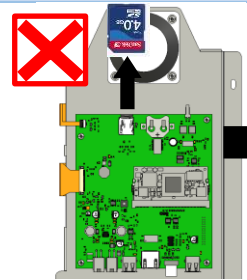
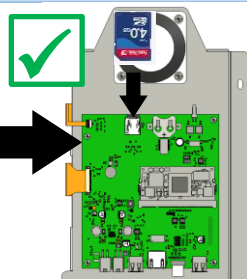
Boards	Faulty board	New board	Application
Main board - Ar			No settings - Automatic recognition between boards
Humidity board - Ahu			No settings - Automatic recognition between boards
Gas board - Aag			No settings - Automatic recognition between boards
Encoder board - Ac			No settings - Automatic recognition between boards
Interface board - Ai			Recover the SD card and insert it on the new Interface board. Copy settings and customer data if the SD card present on the faulty board is recovered.

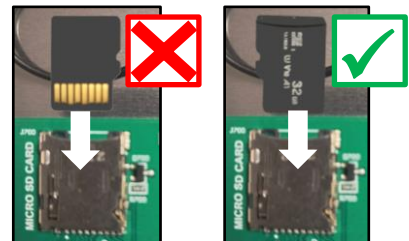

1.1.1 INTERFACE BOARD SETTING

This step is crucial if the interface board on your Chef'sCombi oven is to be replaced. There are two methods available for carrying out this operation: you can either copy the existing configuration using the SD card from the faulty interface board, or you can configure the oven manually. Be sure to follow the instructions carefully to ensure correct configuration.

 It is in your interest to recover the SD card, as all customer data, history, logs, settings and oven configuration will be preserved.

 SD card: Mini 4GB / FAT32 formatted

Replace the SD card on the faulty interface board.

- » When replacing interface board, make sure you recover the SD card present on it.
- » Insert this SD card into the new interface board.
- » Start oven.
 -  Important, When the oven starts up, the system will detect that there is no configuration and will offer to copy the configuration.
 - » If you accept to copy the configuration, the oven will be configured with the previously saved settings.
 - » If you refuse, or if the SD card is corrupted, you will have to configure the oven manually by following the instructions ([▶ Troubleshooting](#) - Reset).

Insert a blank SD card into the Interface board

- » If you do not have the original SD card or if it is damaged, you can use the blank SD card present on the new Interface (check that it is present).
- » Start oven.
 -  When it starts up, the system will detect that there is no configuration and will ask you to configure the oven.
- » Configure the oven manually by following the instructions ([▶ Troubleshooting](#) - Reset).

1.2 REPLACING THE HUMIDITY SENSOR

Prepare your intervention:

- ✓ Remove the left-hand oven cover ([▶ Access to components](#))
- ✓ Tools: 22" spanner

Disconnecting the probe

- » Disconnect the probe at the Black terminal block by pressing on the terminal block tab

Removing the probe

- » Unscrew the probe using the spanner
- » Remove the probe

Fitting the new probe

- » Reposition and screw the probe fully into its housing, taking care not to twist or damage the cable
- » Connect the probe to the black terminal block, taking care to follow the instructions below.

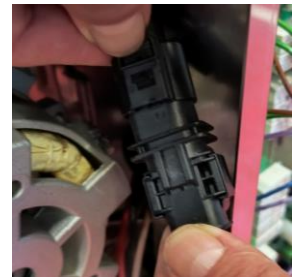
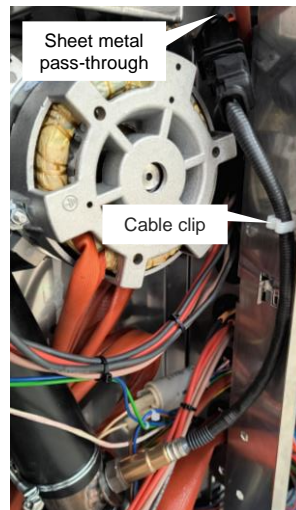

When connecting the new probe to the humidity board, make sure that :

- » The cable is as straight as possible (no loops)
- » The cable is not twisted
- » The cable has passed through the cable clip provided.
- » The cable is routed through the highest grommet on the board to avoid twisting the cable



1.3 REPLACING THE FOOD CORE TEMPERATURE PROBE

Prepare your intervention:

- ✓ Remove the right-hand ladder from the cooking chamber (▶ [Access to components](#))
- ✓ Tools: Wrenches, screwdriver

Disconnecting the probe

- » Unscrew the 2 fixing screws (8 wrench) from the core probe pass-through and remove the 2 screws.
- » Gently pull on the lead wire to access and release the connector.
- » Disconnect the 2 wires from the connector.
- » Remove the probe and its gasket.

Mounting the new probe

- » Connect the probe to the connector and insert the connector into its housing.
- » Position the gasket and attach the probe pass-through to the cooking cavity.

Check / Test

- » Perform the probe calibration procedure.

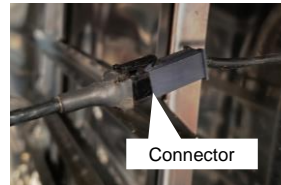

1.4 REPLACING THE TEMPERATURE PROBE OF ELECTRIC STEAM GENERATOR



Locate the probe wires on the terminal block according to color. Red wire: analog, White wire: numeric.



It is imperative to systematically change the probe seals each time the probe is serviced (replacement or inspection).



It is imperative to systematically change the immersion element seal when servicing the immersion element.

Prepare your intervention:

- ✓ Remove the left-hand oven panel (▶ [Access to components](#) - Left-hand side panel)
- ✓ Drain the steam generator (▶ [Troubleshooting](#) - Maintenance screens - Hydraulics diagram)
- ✓ Tools: Wrenches, screwdriver

Probe disconnection

- » Disconnect the wires from the terminal block on the Main board.

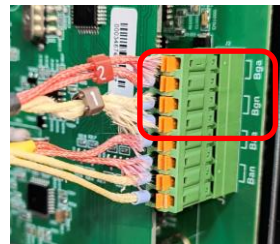

Removing the immersion element

- » Unscrew the 3 flange nuts on the immersion heater fitted with the temperature probe.
- » Remove the immersion element.

Removing the probe

- » Unscrew and remove the clamp holding the probe to the immersion element.
- » Unscrew the probe and remove it.

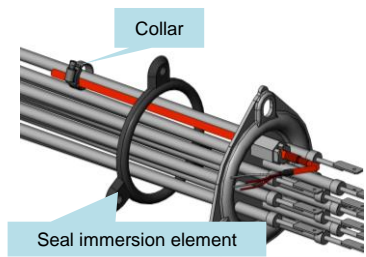
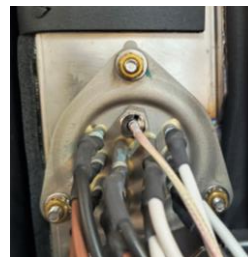

Mounting the new probe

- » Position the new probe on the immersion element according to the instructions.
 - Insert the cable gland and the two seals on the temperature probe.
 - Insert the temperature probe into the immersion element housing, leaving it protruding by 0.4 inch, then tighten the cable gland.
 - Secure the probe to the top bar with a metal Serflex clamp at 0.2 inch from the end of the probe.

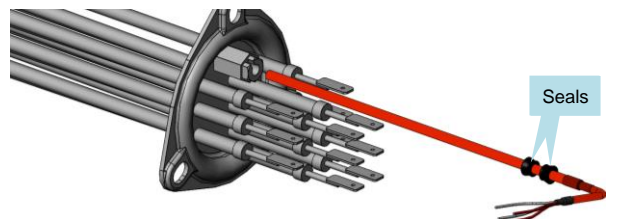

Mounting the immersion element

- » Insert the immersion element into the steam generator not forgetting to change the gasket.

Check / Test

- » Perform the probe calibration procedure.

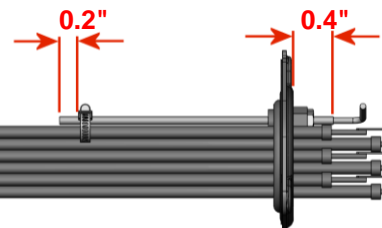

1.5 REPLACING THE TEMPERATURE PROBE OF GAS STEAM GENERATOR



Locate the probe wires on the terminal block according to color. Red wire: analog, White wire: numeric.



It is imperative to systematically change the probe seals each time the probe is serviced (replacement or inspection).

Prepare your intervention:

- ✓ Remove the left-hand oven panel (▶ [Access to components](#) - Left-hand side panel)
- ✓ Drain the steam generator (▶ [Troubleshooting](#) - Maintenance screens - Hydraulics diagram)
- ✓ Tools: Wrenches, screwdriver

Probe disconnection

- » Disconnect the wires from the terminal block on the Main board.

Removing the probe

- » Unscrew the collar holding the probe to the gas steam generator.
- » Remove the probe and the two seals and replace them.

Mounting the new probe

- » Position the new probe in the steam generator according to the instructions
 - Insert the 2 seals on the temperature probe as far as they will go.
 - Insert the probe into the steam generator and tighten with a screw clamp.

Check / Test

- » Perform the probe calibration procedure.

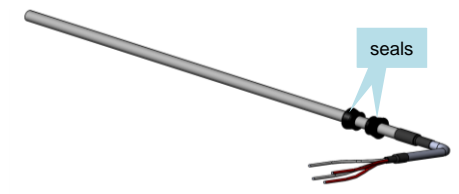
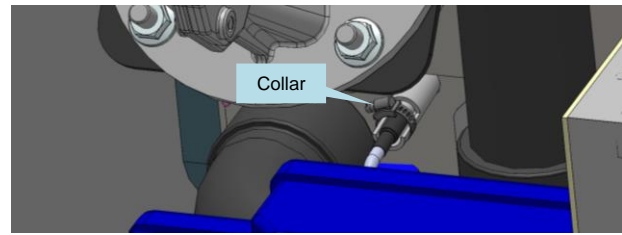
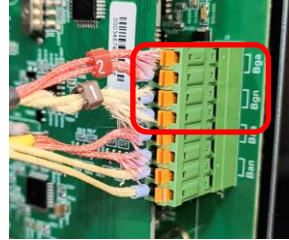

1.6 REPLACING THE AMBIANT TEMPERATURE PROBE



It is imperative to systematically change the probe seal each time the probe is serviced (replacement or inspection).

Prepare your intervention:

- ✓ Remove the left-hand oven panel (▶ [Access to components](#) - Left-hand side panel)
- ✓ Remove the left-hand runner from the oven (▶ [Access to components](#) - Runners)
- ✓ Remove the ventilation duct (▶ [Access to components](#) - Ventilation duct)
- ✓ Tools: Wrenches, screwdriver

Probe disconnection

- » Disconnect the wires from the terminal block on the Main board.

Removing the probe

- » In the technical compartment, unscrew the threaded hexagonal spacer (14 mm spanner) used to secure the probe.
- » Remove the probe and its seal from the inside of the oven.

Mounting the new probe

- » Lubricate and assemble the O-ring with the ambient probe
- » Pass the wires of the new probe through from the inside of the oven.
- » Position and secure the new probe.
- » Insert and press the probe against the inside of the cooking cavity and secure it with the threaded hexagonal spacer.
- » Reconnect the probe wires to the terminal block on the Main board

Check / Test

- » Perform the probe calibration procedure.

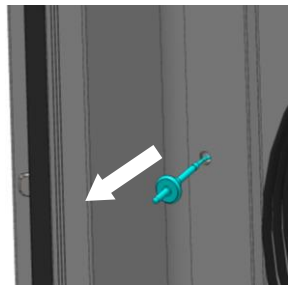
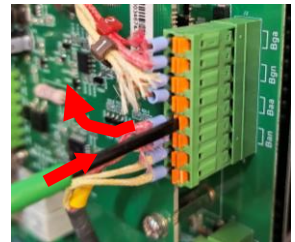
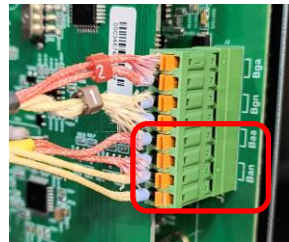

2. SPECIFIC TOOLS

Chapter	Tools	Characteristics	Application
Common	Standard hand tool kit		
	Cutting tools	Retractable blade knife	
	Set of metric wrenches (flat, pipe, ratchet with sockets, Allen Hex Key)	From 5.5 to 22 mm	
	Set of screwdrivers (flat, Phillips)	Phillips.	
	Pliers (multi-socket, flat, cutting, stripping)		
	Measuring tools (tape measure, calliper, level)	Classic tubular level 40cm	
	Wrench		
Water	PPE	Standard	Personal protection for technicians.
	Water control kit	Allows control of Hardness, Cl-, PH, Conductivity and Cl2	Check the characteristics of the water.
Drain	Water pressure gauge	Measuring range 0-10 bar	Check water supply pressure.
	Container	3 litres minimum	Fill the drain box.
Electric	Verification of absence of voltage (VAT)	Max 690V a.c.	Check that there is no voltage.
	Multimeter-Voltmeter	Max 690V a.c.	Various checks on electrical and electronic components.
	Draw knife	Typ : "JOKARI" No 50 and No 28	Pull out the power cable.
	Torque spanner	Type: J208-50 + 13mm 3/8" square socket	Motor mounting: Torque 14N/m.
Gas	Flue gas analyser	Type: "Testo 300 professionnel or equivalent	Check the level of CO emitted when the oven is operating.
	Water column or electronic pressure gauge	Type:Testo 510 or equivalent	Check the gas pressure.
	Spray or Electronic Gas Leak Detector	Type: 1000 Bubbles spray	Check gas connection for leaks.
	Thickness gauges	Dimensions: 6mm and 3.5mm	Position the ignition and detection electrodes.
	Ratchet spanner	Size 8mm M5 screw	Remove the gas exchanger.
	Claw key	Opening 1/2-3/4	Dismantle the gas hoses and connections if the grease collection option is chosen.
Software	USB flash drive	USB2 type: Maximum capacity = 32 GB - FAT32 formatted	Updating software version, copying oven configuration data and customer data (protocols, images, etc.).
Mechanical	Hub puller	Type: "Facom U35.L or similar pulling tool.	Remove the convection fan to service the motor.

3. SETTINGS

3.1 PIN CODES

The access PIN codes are essential for entering the settings menu reserved for the installer, user (after setting by the Chef) and maintenance. They ensure the security and protection of the sensitive settings of your Chef'sCombi oven. Please keep these codes in a safe place and only share them with authorised personnel.

Code No	Description	Level	Remark
0000	Default user code	1	Accessible in the settings / Can be changed by the user.
CHEF	Emergency code for Chef	1	If the password set by the Chef (user) is forgotten (after changing 0000).
INST	Installers	5	Access to installer parameters
SERV	Network Service Technicians	7	Access to 1st level maintenance parameters

3.2 SOFTWARE INITIALIZATION

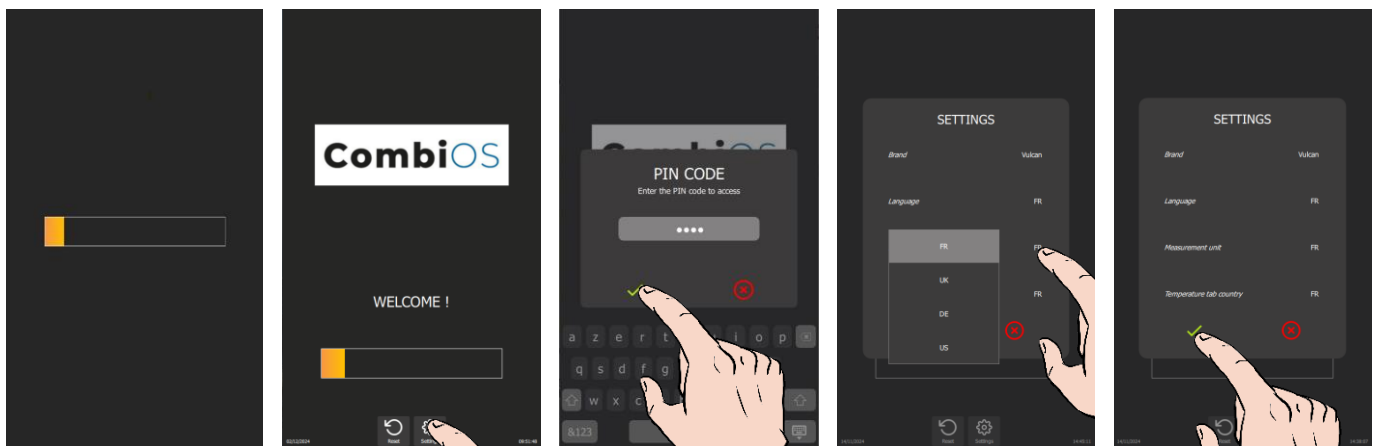

- » Switch on the display by holding down the encoder button.
- » Before the power-on bar graph is displayed, press the « Settings » button.
- ⓘ The PIN code identification pop-up appears.
- » Enter PIN code (level 5 or 7) to access "Installer" parameters (► [Settings](#) - Codes PIN).
- » Confirm by pressing the « ✓ » icon. If the code is correct, access to the screen is authorized; otherwise, return to entering the PIN code
- » Press on the parameter values to modify if necessary.
- ⓘ The selection drop-down menu appears.
 - Select the desired value.
- » Confirm by pressing the « ✓ » icon.

3.3 SETTING THE SOFTWARE LANGUAGE

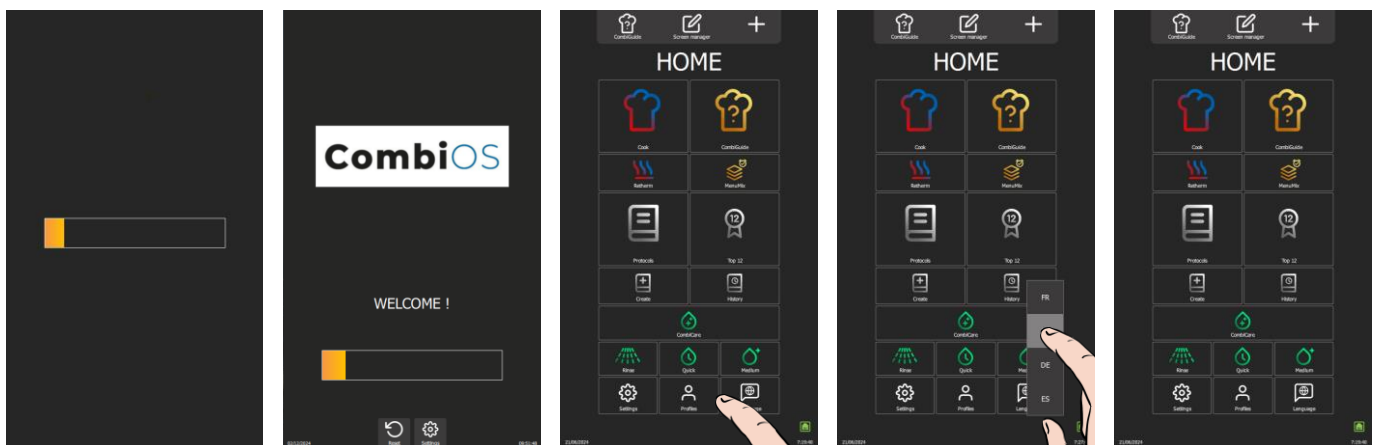

- » Switch on the display by holding down the encoder button until the power-on bar graph is displayed.
- » Wait for the "Home" menu to appear.
- » Press the "Languages" button.
- ⓘ The language selection drop-down menu appears.
- » Select the desired language (En: by example).

3.4 WATER TREATMENT CAPACITY

This counter is only applicable when the oven is supplied by two separate water networks.



- » From the "Home" menu screen, select the "Settings" button.
- » The screen displays the "Parameters" menu with the "User" tab selected.
- » Select "Cooking and Installation choices" button.
- » The screen displays the "Cooking and Installation" settings.
- » Enter the capacity of the water treatment system in litres. Adjustable from 0 to 99999L. The value defaults to 0 if there is no dedicated water treatment for the oven.
 - Select the area of the value to be modified.
 - Set the value using the encoder knob or the keypad.
- » Confirm by pressing "✓" icon.
- » Reset the counter if necessary, by pressing the "Reset" button.
- » Confirm by pressing "✓" icon.

3.5 CHECKING SOFTWARE VERSION

The software version is visible in the "User" tab of the "Settings" screen, below the device serial number.

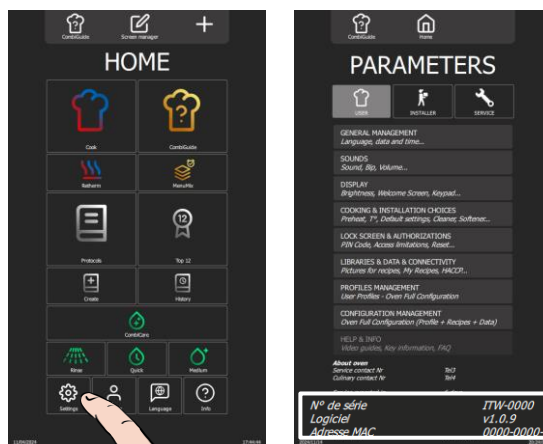

- » From the "Home" menu screen, select the "Parameters" button.
- » The screen displays the "Parameters" menu with the "User" tab selected.

3.6 UPDATING THE SOFTWARE

A regular software update ensures that the oven interface has the latest developments and improvements for use by the customer and/or the technician. The technician is alerted as soon as a new update is available via the "Vulcanequipment.com/resource-center" website software and/or the "software info" distribution.

Before starting the update, check that the software is in the local language and change if necessary.



Warning:
 Do not disconnect the power supply to the device while the software is being loaded.
Do not remove the UBS key while the software is being loaded.
 The oven will be unavailable for the duration of this operation.

USB key

For this configuration operation, you will need a blank FastPad USB key or a blank USB key with the following specifications:

- Maximum capacity = 32 Gb
- Formatted in FAT32 (default allocation unit size = 4096 bytes) or formatted in FAT (default allocation unit size = 32 Kilobytes).



Software update file

Download the software update file "CVxxx-SW.zip" from our Vulcan website maintenance site.
 Unzip the downloaded file.
 Copy the executable file to the blank USB key and run it: fastpad3_imxX_VX.X.XX.upd
 The files will be automatically created on the USB key. The USB key must contain only :

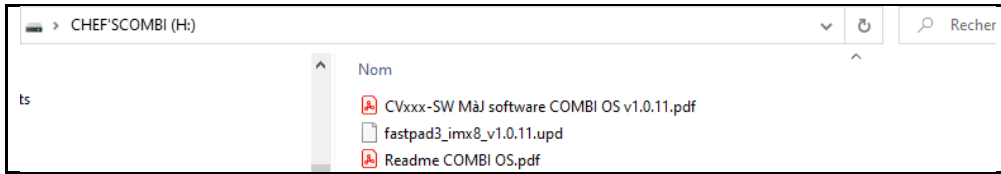

Procedure

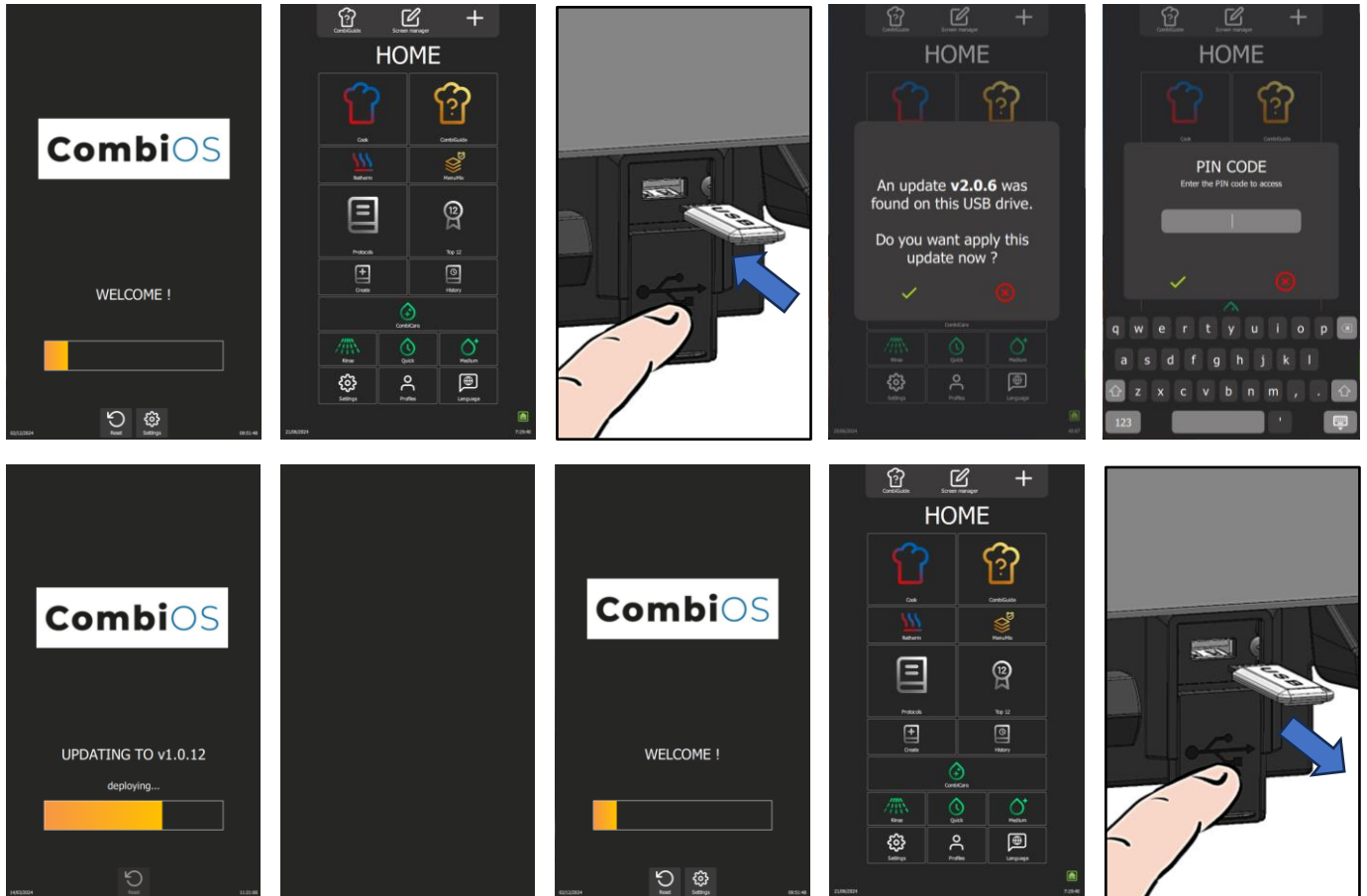

- Step 1 Switch on the device.
Wait for welcome menu to appear. If necessary, skip the pre-heating.
- Step 2 Insert USB key with the new version of Software into the USB socket (next to the spray hose location).
The USB socket has a protective cover.
Lift the cover upwards to insert the USB key.

 **Caution !**
Verify flap has closed as soon as USB socket is no longer in use.

- Step 3 When the USB key is connected, the "UPDATE" request window will appear.
If no window appears, this means software version is identical between the USB key and the device.
- Step 4 Confirm the update by pressing the « ✓ » icon.
- Step 5 Confirm the update by entering your PIN code (level 5 or 7) (► [Settings](#) - PIN Codes).
The device may restart once during the update.
- Step 5 Do not remove the USB key until the welcome screen appears.



3.7 PROBES CALIBRATION



Calibration of the probes (core probe, steam generator probe and cavity probe) must be carried out **systematically** each time these components are replaced.

The cavity probe, core probe and humidity sensor are calibrated during the 'Steam generator calibration' procedure, which takes approximately 12 minutes. If a measured value is inconsistent during the process, interrupt the check immediately by pressing the 'Reject' button. Then switch off the oven and check the probe(s) concerned. Replace faulty components if necessary.

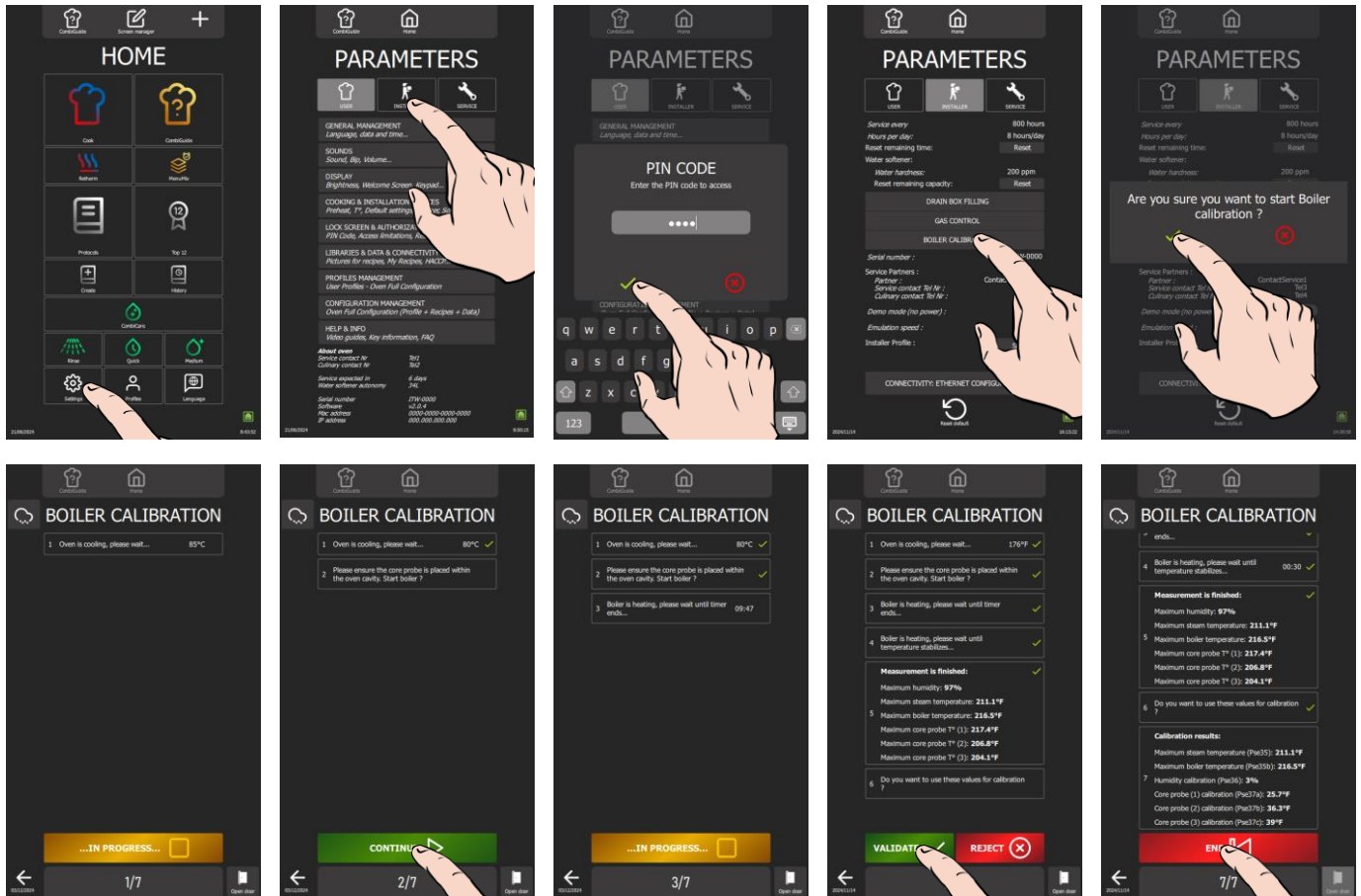

Prepare for your test:

- ✓ The oven door is closed.
- ✓ The left-hand trim panel is in place.
- » From the "Home" menu screen, select the "Settings" button.
- » The screen displays the "Parameters" menu with the "User" tab selected.
- » Select the "Installer" tab.
- » The PIN code identification pop-up appears.
- » Enter the PIN code (level 5 or 7) to access the "Installer" parameters. (► [PIN Codes](#)).
- » Confirm by pressing the "✓" icon. If the code is correct, access to the screen is authorised; if not, return to entering the PIN code.
- » Press the "Steam generator calibration" button
- » Confirm by pressing the "✓" icon.
- » The "Steam generator calibration" screen appears.
- » Start the test by pressing the "Start" button.
- » Follow the actions shown on the oven display "step by step".
- » When point 6 "Do you want to use these values for calibration?" is displayed, press "✓" to confirm.
- » When the calibration result is displayed, press the "End" icon to return to the previous screen.

3.8 PARAMETERS SCREEN

For security reasons, the "Installer" and "Service" tabs are password-protected. You can permanently adjust your device's factory settings by pressing the value of the parameter you want to change or activate. Once settings have been made, the parameters are adjusted immediately.

3.8.1 ACCESSING THE SERVICE SETTINGS MENU

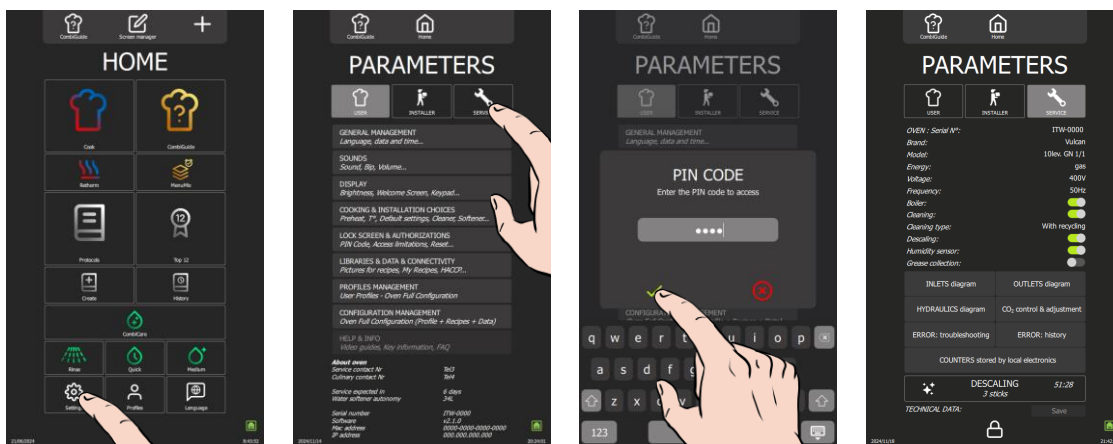

- » On the "Home" menu screen, select the "Parameters" button.
- » The screen displays "Parameters" menu with "User" tab selected.
- » Select "Service" tab.
- » The PIN code identification pop-up appears.
- » Enter PIN code (level 7) to access "Service" parameters (▶ [PIN Codes](#)).
- » Validate by pressing « ✓ » icon. If the code is correct, access to the screen is authorised; otherwise, return to entering the PIN code.

3.8.2 LIST OF PARAMETERS

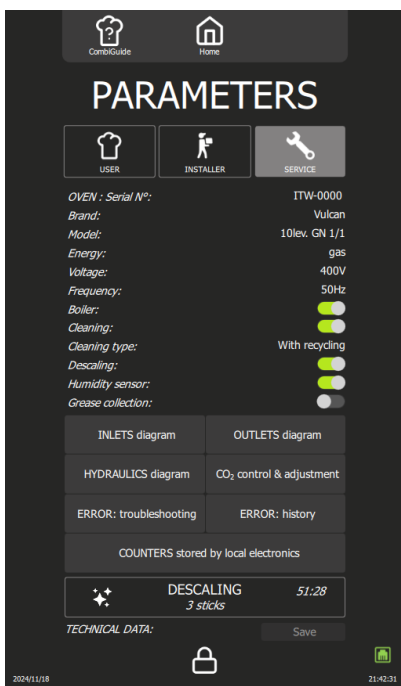

- Oven serial number
- Oven settings
- Maintenance diagrams
- Errors
- Counters
- Descaling the steam generator
- Save maintenance history: Button active if a USB key is connected to the oven

3.8.3 TROUBLESHOOTING ACCESS

Service screens: [Input status screen](#), [Output status screens](#) and [Hydraulics screen](#).
 (▶ [Troubleshooting](#) - Maintenance screens)

Error: Troubleshooting

The screen displays the error table, starting with the first number listed in the error table (▶ [Errors messages](#)). To scroll through the numbers, use the encoder to scroll to the desired number.

Alternatively, you can click on the number field to bring up the keypad and enter the desired target number directly.

You can access this screen by selecting an error line in the error history (▶ [Error: History](#)). When browsing the history, click on the specific error to be automatically redirected to this screen. This feature enables efficient incident management, providing quick access to specific error details.

Error : History

The Error History screen provides a detailed view of incidents that have occurred, presented in chronological order from most recent to oldest. This feature enables users to follow and understand the evolution of problems encountered by the Chef'sCombi.



Error messages are recorded in the history for a set period of 6 months; ensuring reliable tracking of incidents over an extended period.

Counters

The counter screen lists all the counters, with a history for the main counters. Following values for main counters, you will find the following values:

- The total value since the oven was switched on.
- Values for the last 7 days (D, D-1, D-2, D-3... D-7).
- Values for the last 12 months (M, M-1, M-2, M-3... M-12).

Note: Some counters can only display the current day's value, with no history of previous days.

List of counters

Designation	Units
Total operating time	Seconds
Cooking time convection mode	Seconds
Cooking time steam mode	Seconds
Cooking time combi mode	Seconds
Total time in cooking cycle	Seconds
Total time in cleaning cycle	Seconds
Hard water consumption	Millilitre
Softened water consumption	Millilitre
Elec. energy consumption	0.1Wmin
Gas energy consumption	0.1Wmin
Water consumption since last reset	Litre
Remaining water capacity	Litre
Hours elapsed since last service	Hours
Remaining hours before service	Hours
Cooking seconds elapsed since last cleaning	Seconds
Cleaning status	-
Number of completed cooking cycles	-
Number of completed cleaning cycles	-
Number of completed descaling cycles	-
Total operating time	Seconds
Cooking time convection mode	Seconds
Cooking time steam mode	Seconds
Cooking time combi mode	Seconds
Total time in cooking cycle	Seconds
Total time in cleaning cycle	Seconds
Hard water consumption	Litre
Softened water consumption	Litre
Elec. energy consumption	KWh
Gas energy consumption	KWh
Elec. energy consumption last cycle	KWh
Gas energy consumption last cycle	KWh
Water consumption last cycle	Litre
Duration last cycle	Seconds
Elec. energy consumption per cycle	KWh
Gas energy consumption per cycle	KWh
Water consumption per cycle	Litre
Average duration per cycle	Seconds
Elec. energy consumption last hour	KWh
Gas energy consumption last hour	KWh
Water consumption last hour	Litre
Average duration last hour	Seconds
Elec. energy consumption per hour	KWh
Gas energy consumption per hour	KWh
Water consumption per hour	Litre
Average duration per hour	Seconds
Total cleaning tabs consumption	-
Total descaling sticks consumption	-

Designation	Units
S01 CAVITY LIGHT (MOS)	-
S02 DAMPER (MOS)	-
S03 GREASE PUMP (MOS)	-
S04 DESCALING PUMP (RELAY)	-
S05 CAVITY DRAIN PUMP (RELAY)	-
S06 STEAM GENERATOR DRAIN PUMP (RELAY)	-
S08 TECH FAN (RELAY)	-
S09 KP (RELAY)	-
S10 POWER HEAT 1 (RELAY)	-
S11 POWER HEAT 2 (RELAY)	-
S12 POWER HEAT G (RELAY)	-
S13 CLEAN PUMP (RELAY)	-
S15 SPRAY VALVE (RELAY)	-
S16 DESCALER DISSOLUTION VALVE (RELAY)	-
S18 CONDENSER VALVE (OPTO)	-
S19 COOLING VALVE (OPTO)	-
S20 STEAM GENERATOR FILLING VALVE (OPTO)	-
S22 FAN OPERATION (TRIAC)	-
S23 FAN DIRECTION (RELAY)	-
SR1 COOKING STATE (RELAY)	-
S01 CAVITY LIGHT (MOS)	Seconds
S02 DAMPER (MOS)	Seconds
S03 GREASE PUMP (MOS)	Seconds
S04 DESCALING PUMP (RELAY)	Seconds
S05 CAVITY DRAIN PUMP (RELAY)	Seconds
S06 STEAM GENERATOR DRAIN PUMP (RELAY)	Seconds
S08 TECH FAN (RELAY)	Seconds
S09 KP (RELAY)	Seconds
S10 POWER HEAT 1 (RELAY)	Seconds
S11 POWER HEAT 2 (RELAY)	Seconds
S12 POWER HEAT G (RELAY)	Seconds
S13 CLEAN PUMP (RELAY)	Seconds
S15 SPRAY VALVE (RELAY)	Seconds
S16 DESCALER DISSOLUTION VALVE (RELAY)	Seconds
S18 CONDENSER VALVE (OPTO)	Seconds
S19 COOLING VALVE (OPTO)	Seconds
S20 STEAM GENERATOR FILLING VALVE (OPTO)	Seconds
S22 FAN OPERATION (TRIAC)	Seconds
S23 FAN DIRECTION (RELAY)	Seconds
SR1 COOKING STATE (RELAY)	Seconds

Descaling

Descaling enables the oven and steam generator to be descaled by force. Pressing the button starts a descaling process at the maximum level for the oven without the cleaning program. The number of sticks required is clearly indicated and varies according to the oven model. The descaling process is similar to that used for a wash with descaling and is carried out automatically.

Save

The save function automatically exports all the oven's essential parameters and data to a USB stick, organising them in different files for more efficient management. Each type of data is saved in a separate file, including connectivity logs, errors, counters, cooking parameters and appliance configuration. These files are automatically filed in a specific folder, created on the USB key, guaranteeing a complete and organised backup of maintenance data.

The function is accessible if a USB stick is plugged into the USB socket.



4. PREVENTIVE MAINTENANCE

To ensure that your equipment operates safely and reliably over the long term, we recommend that you have it checked and serviced by our qualified personnel.

The customer is automatically notified of the need for preventive maintenance. The overhaul counter is determined according to the frequency of use of the oven and the number of hours between each intervention. These values must be entered by the technician at the time of installation and checked at each service.

4.1 LIST OF ACTIONS



WARNING : The appliance must be disconnected from its power supply during cleaning or maintenance, and when replacing parts.

Subject	Recommendations (Every year or every 3000h)
General	
Earthing	Check the continuity of the earthing system
Oven position	Levelling, loading sill height, adjust if necessary.
Fixing the oven	If the appliance is fixed, check that it is correctly fixed.
Facia / Screen	
Control panel sealing	Check that the control panel is watertight. If there are any leaks, make it watertight
Screen electronics / Interface board	No traces of dirt or dust deposits on the components - Clean and seal the compartment. - Check that the screen is securely fastened to the bracket, as this ensures that it is watertight.
Screen connections	No traces of oxidation on the USB / RJ45 plug connectors - Replace if necessary.
Encoder board	No signs of dripping or oxidation - Check that it is working properly.
Encoder button	Check that it is in good condition and securely fixed, with no excessive play or wear, etc. - Replace if necessary.
USB compartment / Spray hose	
USB compartment	Check the condition of the USB socket: no deformation, no oxidation, check the closing flap, good general condition, closing spring working, compartment completely sealed - Replace if necessary.
Spray hose	Check the condition of the spray hose: no blockages, no leaks - dismantle and clean - Check the supply pipe: no leaks, no cracks in the pipe - Check the reel: secure and return spring in good working order - Replace if necessary.
Technical compartment	
Air vents / technical fan	Clean the inlets - Clean the fan blades
Power supply terminals	Check that there are no signs of overheating - Tighten the connections
Fuse holders (if any)	Check that there are no signs of overheating - Tighten the connections
Contactors	Check that there are no signs of overheating - Tighten the connections
Main board	Remove dust - Check that there is no oxidation on the output contacts - Check the condition of the fuses (visual check of the status LEDs) - Check that the connector screws are tight and that they are correctly connected.
Valve In	Check the general tightness - Check the seal - Clean - Using the maintenance table, operate and check that there is no noise, depending on the model, check the operation of the associated motor, noise, etc. - Replace if necessary.
Heater	
Ventilation motor	Using the maintenance table, operate the motor and check that there are no abnormal noises - Systematically replace the motor shaft seal - Check that the mechanical fasteners are tight - Lubricate the motor shaft (high-temperature lubricant).
Resistors	Check the condition of the supply wiring, cables in good condition, no cracks in the insulation. Heat-shrink tubing present and in good condition. - Repair or replace if necessary.
Intensity measurement (convection heat 180°C)	Measure the current on each phase of each heating element and check that there is no imbalance between phases and no drift from one test to the next. - Replace the element if necessary.
Gas or electric steam generator	
Steam generator body	Descale if necessary (remove at least one immersion heater for visual inspection) - Replace the seal - Check that there are no traces of dripping at the hydraulic connections.
Immersion heaters	Dismantle only if leaking - Replace seal - Check condition of wiring and heat-shrink tubing - Repair or replace if necessary.
Intensity measurement (100°C steam heater)	Measure the current on each phase of each heating element and check that there is no imbalance between phases and no drift from one test to the next. - Replace the element if necessary.
Level probe	Dismantle and clean - Check that the connections (probe and earth) are tight and that the thread is watertight.
Hydraulic	
General waterproofing	Carry out a visual check.
Water inlet	Cleaning the filter.
Solenoid valves	Check that there is no indication of overheating in the coils (change of colour if necessary) - Check operation using the maintenance menu, leave the solenoid valves operating and check the various circuits, seals, tightness of connections, etc. - Re-seal or replace the hoses if necessary, and the solenoid valves if necessary.
Cleaning / descaling circuit	Check the condition of the descaling box: that the descaling flap is working properly, and that the grille is clean and in good condition - clean if necessary. Check the condition of the pipework: connections, hoses, no leaks. Check the pump: using the maintenance menu, turn it over and check that there are no abnormal noises, no leaks, and that the electrical connections are free from gap or oxidation. Replace if necessary. Check that there are no foreign bodies in the tank.

Subject	Recommendations (Every year or every 3000h)
Hydraulic	
Steam generator drain circuit	Check the condition of the pipework: connections, hoses, no leaks. Check the pump: using the maintenance menu, turn it over and check that there are no abnormal noises, no leaks, and that the electrical connections are free from gap or oxidation. Check for leaks or replace the pump if necessary.
Clean box drain circuit	Check the condition of the pipework: connections, hoses, no leaks. Check the pump: using the maintenance menu, turn it over and check that there are no abnormal noises, no leaks, and that the electrical connections are free from gap or oxidation. Check for leaks or replace the pump if necessary.
Cleaning pump	Lubricate the bottom bearing of the pump with WD40 type lubricant product.
Cavity	
General condition	Check that there are no rust stains and that cleaning and descaling are effective.
Joint	Clean - Check general condition - Replace if necessary.
Core probe	Check the general condition (tip, cable) - Check that the bulkhead feed-through is tight and watertight - Check that it is working properly by starting a firing and checking the temperature change.
20-level oven ventilation duct	Check that the lower axle ring is present and that it functions correctly (pivoting; hooking in).
Sprinkler	From the maintenance menu, activate the wash pump and visually check the water flow - Clean the nozzles and retighten if necessary.
Water injection tube	Internal cleaning - Descaling if necessary - Changing the seal if necessary - Mechanical fastening.
Drain	Check that the grille is clean, tight and watertight. Change the seal if necessary.
Under-door trunking	Check the drain and flue for leaks and cleanliness - Re-seal if necessary.
Ladders	Check that there is no corrosion and that the fixings and rails are in good condition. - Repair if necessary.
Door	
Top and bottom hinges	Check general condition (wear, etc.); Lubricate and tighten if necessary.
Internal door	Condition and presence of the door stops (complete if necessary); Check that the springs are correctly pivoted and effective (adjust if necessary).
Lighting	General operation - Condition of label (must be watertight) - Clean - Replace if necessary
Door closing mechanism	Check clearances and general tightness - Check the state of wear of friction parts - Readjust if necessary.
Bottom door seal (20 levels only)	Clean and check general condition - Replace if necessary.
Gas ovens only	
Gas connection	If the connection is made with a flexible hose, check its suitability for use (date, condition, etc.) - Replace if necessary
Gas pressure	Check the "static" and "dynamic" pressures at the appliance inlet - Adjust if necessary.
Combustion	Refer to the installation manual to carry out this check.
Exchangers	Visually check the general condition and tightness of the flanges in relation to the technical compartment - Check the fixing points.
Ignition control / Flame safety / Burner motor speed	Carry out the checks suggested by the technical screen in the maintenance menu before any dismantling - Observe the results and, if necessary, follow the appropriate procedure.
Tightness of the gas circuit	Using a product such as "Mille Bulles", check the tightness of the connections upstream of the gas valves and downstream of each connection when the burner is operating.
Safety checks	Switch off the gas supply while the burner is operating - The burner must go into safety mode
Plastic fireplaces	Check their presence and condition and clean if necessary.
Gas valves	Check: tightening of electrical control retaining screws, condition of metal hoses, tightness of connections, etc. - Readjust in accordance with the instructions in this manual - Replace if necessary.
Burner motor	Check during operation that there are no abnormal noises - Replace if necessary.
Grease collection option	
Grease pump	Check the general condition, in particular that there are no leaks or drips, and that the electrical connections are in good condition: no overheating, no traces of oxidation, etc. Using the maintenance menu, run the motor and check that there are no noises - Replace if necessary.
Circuit	Check the condition of the pipes: no leaks, no cracks, no brittleness, no deformation or blockages. - Replace defective parts if necessary.
Valve	Check general condition: no excessive gap at the handle, tightness of connections. - Replace if necessary.
Safety valve	Check that it is working: close the grease outlet valve and activate the pump, the valve will discharge the liquid - If not, replace the valve.
Safety pressure switch	Check that it is working: close the grease outlet valve and activate the pump. The pump should stop and an error message should appear on the display. If this is not the case, replace the pressure switch.

4.2 SETTING MAINTENANCE INTERVENTION FREQUENCY, DAILY USAGE RATE

Access to the Installer parameters menu

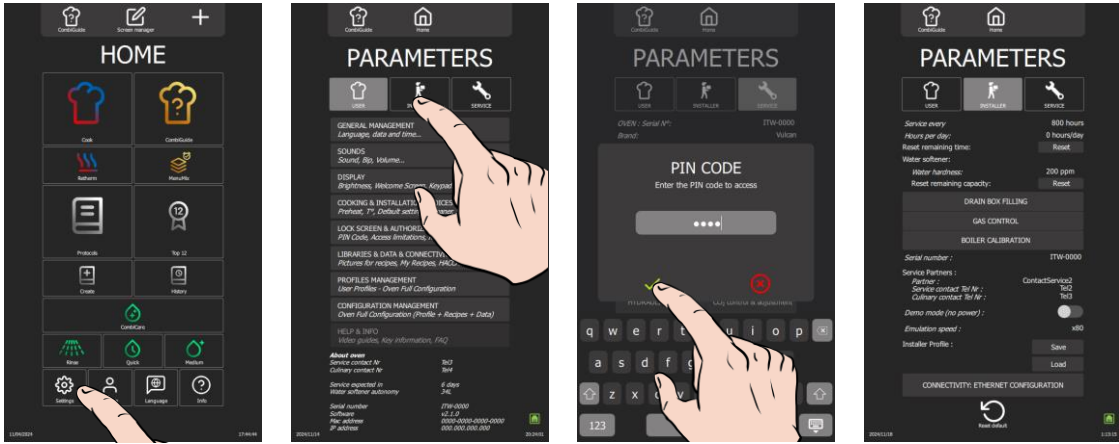

- » From the "Home" menu screen, select the "Settings" button.
- ☒ The screen displays the "Parameters" menu with the "User" tab selected.
- » Select the "Installer" tab.
- ☒ The PIN code identification pop-up appears.
- » Enter PIN code (level 5 or 7) to access the "Installer" (► [Settings](#) - PIN Codes).
- » Confirm by pressing "✓" icon. If the code is correct, access to the screen is authorised; if not, return to entering the PIN code.

Frequency of maintenance work and rate of use per day

The frequency of maintenance interventions and the rate of use per day are calculated in the table below according to the information supplied by the customer at the time of installation, such as the number of hours the appliance is used per day and the type of cooking performed. It is the responsibility of the technician to check that these settings correspond to the actual use of the oven, and to modify them if necessary (according to the table below):

Type of use (Customer information)	Hours of use / day (Customer information)		Setting the installation parameters (to be entered in the Installation parameters)	
			Maintenance every (in hours)	Hours per day* (in hours)
NORMAL USE (Restaurants, etc.)	LIGHT	< 7 h	2000	6
	STANDARD	7-12 h	3000	8
	INTENSIVE	12-17 h	3000	16
	VERY INTENSIVE	17-24 h	3000	24
COOKING >428°F and/or COOKING FATTY PRODUCTS (e.g. chicken rotisserie)	STANDARD	< 7 h	3000	8
	INTENSIVE	7-12 h	3000	16
	VERY INTENSIVE	12-17 h	3000	24
		17-24 h		

* hours of use

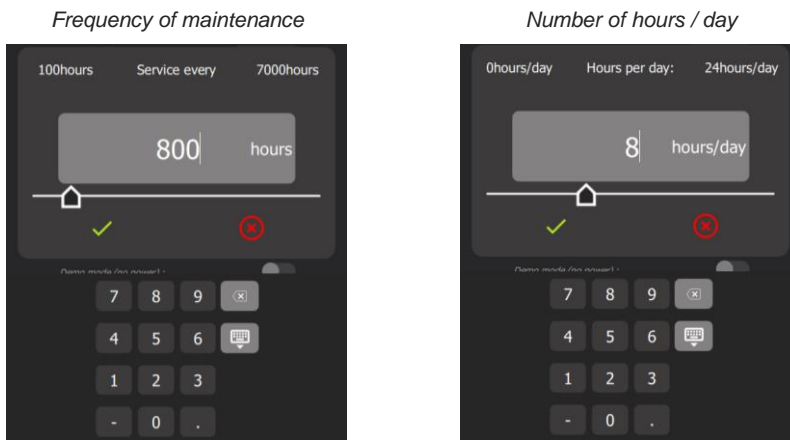

- » Press number of hours input box.
- ☒ The screen displays a keypad and the number entry field.
- » Enter number of hours before the next maintenance (800h by default): Adjustable from 100 to 7000 hours. It's essential that you plan to have your appliance serviced at least once a year.
 - Select the area of the value to be modified.
 - Set the value using the encoder knob or the keypad.
- » Confirm by pressing "✓" icon.
- » Select box to enter number of hours of use per day.



4 - PREVENTIVE MAINTENANCE

- ⓘ The screen displays a keypad and the number entry field.
- » Enter average hours appliance is in use each day. NOTE: This can be adjusted from 0 to 24 hours.
 - Select area of the value to be modified.
 - Set value using the encoder knob or the keypad.
- » Confirm by pressing "✓" icon.

Resetting the counter

- » Reset the counter
 - Press the "Reset" button.
- » Confirm by pressing "✓" icon.

5. TROUBLESHOOTING

5.1 TROUBLESHOOTING METHOD



Before replacing components without being certain of the problem, it is important to use all the tools supplied with the oven to target the real problem: error history, counters, error message and associated solutions, test using the technical screens, check the status of the LEDs, etc...

1. Interview the customer:

- Collect as much information as possible from the user about the problems encountered (frequency, anomalies, blocking errors, etc.).

2. Identify the problem:

- Check combi steamer is correctly supplied with electricity or gas, water and drain, depending on the type of model used.
- Visually inspect interior of the oven for signs of possible damage or obstructions.
- Check the indications potentially provided by the Chef'sCombi: the error history, counters, ... may give indications of the type of problem encountered, its frequency
- Write down the details of the problem encountered, for better understanding.

3. If an error message is displayed: Fault search with ERROR MESSAGE

- Follow instructions given in the error message.
- Refer to error table in this manual if necessary for further information on the specific error code encountered (▶ [Troubleshooting - Errors messages](#)).

4. If no error message is displayed:

- Fault-finding via the maintenance screens
 - ❖ Check different components via the maintenance screens of outlets, inlets and hydraulics in the maintenance parameters of the oven interface (▶ [Troubleshooting - Maintenance screens](#)).
 - ❖ Refer to this manual to understand their meaning.
 - ❖ Write down any anomalies and proceed with troubleshooting.
- Fault-finding via communication LEDs
 - ❖ Identify LEDs on the oven boards (▶ [Troubleshooting - Communications LEDs](#)).
 - ❖ Refer to the LED guide to understand their meaning (▶ [Troubleshooting - Communications LEDs](#)).
 - ❖ Proceed with troubleshooting.
- Fault-finding OTHER:
 - ❖ Consult the manual to access available diagnostics (▶ [Troubleshooting - Other symptoms](#)).
 - ❖ Follow the flow charts provided to diagnose the problem and identify the appropriate troubleshooting steps (▶ [Troubleshooting - Flow charts](#)).
 - ❖ Consult the electrical diagrams (▶ [Electric diagrams](#)).

5. Contact technical support if necessary:

- If the problem persists or if you are unable to solve the problem using the above steps, contact the manufacturer's technical support. Please always direct service questions to combi.tech@vulcanequipment.com or (800) 814-2028, select prompt #2, then #8.
- Give all the relevant information you have collected during diagnosis for effective assistance.

5.2 ERRORS MESSAGES



To facilitate the intervention, hang the Main board in the maintenance position (▶ [Access to components](#) – Maintenance position of the Main board assembly).

Code	Title	Probable Causes	What to do?
E00	Cavity overheat greater than 626°F	Control contacts stuck.	POWER OFF: Using an ohmmeter, place the test probes on the terminal clamping screws to check the resistance between L and T for each pole of the Kr contactor(s). The value must be equal to "OL"; if not, replace the faulty contactor(s).
		Output S10 of the Main board permanently activated.	POWER OFF: Using an ohmmeter, place the test probes on the terminal clamping screws and check the continuity between the "230Vac" terminal of connector J15 and the "S10" output of connector J16 on the Main board. If there is continuity, replace the Main board.
		Output S11 of the Main board permanently activated (gas ovens 20 levels only).	POWER OFF: Using an ohmmeter, place the test probes on the terminal clamping screws and check the continuity between the "230Vac" terminal of connector J15 and the "S11" output of connector J16 on the Main board. If there is continuity, replace the Main board.
<i>To reset this fault, the power supply to the oven must be cut off by disconnecting the associated protection circuit breaker.</i>			
E01	Ambient probe cavity fault.	Open "Inlets Diagram" in the "Service" screen and check the temperature indicated by the 'Ban' ambient probe. If the value is "-°F," the sensor circuit is faulty (short-circuited or open). Check the following points:	
		Wire broken in probe or input connection "Ban"	POWER OFF: check that the connector is properly inserted into its socket and that each wire is connected to each terminal on the connector. If the problem persists, disconnect the Pt100 "Ban" probe from connector J2 on the Main board and measure between the two white wires using an ohmmeter. (By example, the temperature of the cavity is between 70°F and 80°F, the measured value will be between 108 Ω and 110 Ω). If the measured value is "OL," the circuit is open. Repair the connection, or replace the sensor.

Code	Title	Probable Causes	What to do?
		Short circuit in the probe or probe input connection "Ban"	POWER OFF: check that the connector is properly inserted into its socket and that each wire is connected to each terminal on the connector. If the problem persists, disconnect the Pt100 "Ban" probe from connector J2 on the Main board and measure between the two white wires using an ohmmeter. (By example, the temperature of the cavity is between 70°F and 80°F, the measured value will be between 108 Ω and 110 Ω). If the value measured is less than 100 Ω, there is a short circuit. Repair the connection, or replace the probe.
		Main board electrical fault	POWER OFF: if the probe and its connection are working, replace the Main board.
	<i>To reset this fault, the power supply to the oven must be cut off by disconnecting the associated protection circuit breaker.</i>		
E02	Ambient probe cavity fault.	Wire broken in probe or input connection "Baa"	POWER OFF: check that the connector is properly inserted into its socket and that each wire is connected to each terminal on the connector. If the problem persists, disconnect the Pt100 "Baa" probe from connector J2 on the Main board and measure between the two white wires using an ohmmeter. (By example, the temperature of the cavity is between 70°F and 80°F, the measured value will be between 108 Ω and 110 Ω). If the measured value is "OL," the circuit is open. Repair the connection, or replace the probe.
		Short circuit in the probe or probe input connection "Baa"	POWER OFF: check that the connector is properly inserted into its socket and that each wire is connected to each terminal on the connector. If the problem persists, disconnect the Pt100 "Baa" probe from connector J2 on the Main board and measure between the two white wires using an ohmmeter. (By example, the temperature of the cavity is between 70°F and 80°F, the measured value will be between 108 Ω and 110 Ω). If the value measured is less than 100 Ω, there is a short circuit. Repair the connection, or replace the probe.
		Main board electrical fault	POWER OFF: if the probe and its connection are working, replace the Main board.
	<i>To reset this fault, the power supply to the oven must be cut off by disconnecting the associated protection circuit breaker.</i>		
E10	Steam generator scale.	Water hardness is incorrectly set in the installation parameters	Measure the water hardness and adjust the hardness parameter in the installation settings. Carry out descaling cycle from the "Service" screen.
		Defective water softener or water filter	Measure water hardness and check or have checked that the water softener and the water filter are working properly. Carry out descaling cycle from the "Service" screen.
		Limescale has built up in the steam generator and the recommended descaling cycles have not been carried out.	Carry out descaling cycle from the "Service" screen.
E11	High level of steam generator scale.	Water hardness is incorrectly set in the installation parameters	Measure the water hardness and adjust the hardness parameter in the installation settings. Carry out descaling cycle from the "Service" screen,
		Defective water softener or water filter	Measure water hardness and check or have checked that the water softener and the water filter are working properly. Carry out descaling cycle from the "Service" screen,
		Limescale has built up in the steam generator and the recommended descaling cycles have not been carried out.	Carry out descaling cycle from the "Service screen".
E12	Steam generator overheat greater than 266°F	The Steam generator is heating; however, the water level is low: The water level controller is faulty.	Check the functionality of the water level control "BnC" from "Inlets diagram" in the "Service" screen: => If the control probe is immersed in water, BnC = 1 => If the control probe is not in water, BnC = 0. If not functioning, check the state (Presence of calcium; Mineral fouling...).
		Steam generator heats even though water level is too low: Sensor connection short-circuited or grounded.	Disconnect the connector J1 on the Main board and take a reading between the terminals "BnC" and "EARTH" using an ohmmeter; If there is a short circuit, the ohmmeter indicates a value close to "0" Ω, then locate the fault and repair as required.
		The Steam generator is heating; however the water level is low: Input "BnC" at the Main board is defective.	Replace the Main board
E13	Steam generator temperature probe fault	Open "Inlets diagram" in the "Maintenance" screen and check the temperature indicated by the "Bgn" steam generator probe. If the value is "-°F", the sensor circuit is faulty (short-circuited or open). Check the following points: Wire broken in probe or input connection "Bgn"	POWER OFF: check that the connector is properly inserted into its socket and that each wire is connected to each terminal on the connector. If the problem persists, disconnect the Pt100 "Bgn" sensor from connector J2 on the Main board and measure between the two white wires using an ohmmeter. (By example, the temperature is between 70°F and 80°F, the measured value will be between 108 Ω and 110 Ω). If the measured value is "OL," the circuit is open. Repair the connection, or replace the probe.
		Short circuit in the probe or probe input connection "Bgn"	POWER OFF: check that the connector is properly inserted into its socket and that each wire is connected to each terminal on the connector. If the problem persists, disconnect the Pt100 "Bgn" probe from connector J2 on the Main board and measure between the two white wires using an ohmmeter. (By example, the temperature is between 70°F and 80°F, the measured value will be between 108 Ω and 110 Ω). If the value read is less than 100 Ω, there is a short circuit. Repair the connection, or replace the probe.

Code	Title	Probable Causes	What to do?
		Main board electrical fault	POWER OFF: If the probe and the connections are functioning, replace the Main board.
E14	Steam generator temperature probe fault.	Wire broken in probe or input connection "Bga"	POWER OFF: check that the connector is properly inserted into its socket and that each wire is connected to each terminal on the connector. If the problem persists, disconnect the Pt100 "Bga" sensor from connector J2 on the Main board and measure between the two red wires using an ohmmeter. (By example, the temperature is between 70°F and 80°F, the measured value will be between 108 Ω and 110 Ω). If the measured value is "OL," the circuit is open. Repair the connection, or replace the probe.
		Short circuit in the probe or probe input connection "Bga"	POWER OFF: check that the connector is properly inserted into its socket and that each wire is connected to each terminal on the connector. If the problem persists, disconnect the Pt100 "Bga" probe from connector J2 on the Main board and measure between the two red wires using an ohmmeter. (By example, the temperature is between 70°F and 80°F, the measured value will be between 108 Ω and 110 Ω). If the value read is less than 100 Ω, there is a short circuit. Repair the connection, or replace the probe.
		Main board electrical fault	POWER OFF: If the probe and the connections are functioning, replace the Main board.
<i>To reset this fault, the power supply to the oven must be cut off by disconnecting the associated protection circuit breaker.</i>			
E15	The level of water in the steam generator has not been reached after 117 seconds.	Water supply closed	Check that the water supply in-line valves are open
		Water pressure too low	Measure the water pressure at the oven connection. When the water supply to the oven is maximum, the pressure must be greater than 1.5 bar.
		The Steam generator is not being fed water: The fuse "F1" of the Main board has blown (LED "800" off (► LEDs identification))	Check the cause of blowing, and the state of condenser's solenoids (Ycond.) and cooling's solenoid (Ycool). Make the repair and change the fuse by a fuse of the same models.
		The Steam generator is not being supplied water: The output "S20" of the Main board is faulty.	Press the "Yboiler" button from "Hydraulics diagram" in the "Service" screen, and measure the voltage between the output "S20" of the Automate and terminal "Xb". If the voltage is less than 230V, change the Main board.
		Steam generator is not being supplied water: Then steam generator fill solenoid valve is defective.	WARNING: The output is controlled by a triac: a voltage at the output can be measured even if the triac is not open.
		The Steam generator is not being supplied water: Then Steam generator fill solenoid valve is defective.	Disconnect the water supply pipe from the steam generator at the elbow and place it in a container. Press the "Yboiler" button from "Hydraulics Diagram" in the 'Service' screen, and check that water is coming out of the pipe. If no water is flowing, the "Yboiler" steam generator fill solenoid valve is defective and must be replaced.
		Water flow rate too low.	Disconnect the water supply hose from the steam generator at the elbow and place it in a container. Press the "Yboiler" button from "Hydraulics Diagram" in the "Service" screen and let the water run into the container for as long as the solenoid valve is open (1 minute). The amount of water collected should be approximately 1,3 gallons. If it is less than this, check the condition of the filters and flow limiter in the solenoid valve (clogging, etc.). Clean them or replace the solenoid valve.
E16	Steam generator drainage pump fault.	24/230Vac supply voltage input fault	With a voltmeter, check the supply voltage between input 24/230Vac of the Main board and terminal "Xb". This voltage should be 230V (120V on ovens version "UL"). If not, find the cause of the fault and repair as required.
		Fuse F4 blown (LED "702" off (► LEDs identification))	Find the cause of the blowing, check the state of the descaling pump (Mdg) and the cavity drain pump (Mvm). Make repairs and replace the fuse with the same model.
		Fault with the Main board switch S06	Connect a voltmeter between the terminal S06 of the Main board and terminal Xb. Activate relay output S06 from "Outlets diagram" in the "Service" screen. If the voltage reads zero when the relay is operated, replace the Main board.
		The drainage pump is not powered	Connect a voltmeter to the terminals of the Steam generator drain pump (Mvg). Activate relay output S06 from "Outlets" diagram in the "Service" screen. If the voltage reads zero when the relay is operated, check the pump cabling and repair as required.
		Steam generator drainage pump defective or blocked.	Activate relay output S06 from "Outlets" diagram in the "Service" screen. If the pump does not function, visually check its state: clean or swap out as required.
		Steam generator water level control failure	Check the operation of the "BnC" water level control from the "Inlets diagram" in the "Service" screen: if water is present, BnC = 1; if the probe is out of the water, BnC = 0. If this is not the case, check the condition of the probe (limescale, dirt) and its electrical connection. If the probe is working, replace the Main board.
E20	The level of water in the cleaning tank has not been reached after 50 seconds.	Water supply closed	Open the water supply
		Water pressure too low	Check the water pressure at the oven connection. During maximum kitchen water use, the pressure must be greater than 1.5 bar.
		Water flow rate too low.	Check the state of the filter and of the condenser flow limiting solenoid valve (Fouling...). Clean if required. The water flow rate should be approximately 5l/min.

Code	Title	Probable Causes	What to do?
		Fuse F1 blown (LED "702" off (► LEDs identification))	Find the cause of the blowing, check the state of the Ycond and Yboiler solenoid valves. Carry out repairs and replace the fuse with the same model.
		Fault with the Main board output S18	Connect a voltmeter between the terminal S18 of the Main board and terminal Xb. Activate relay output S18 from "Outlets diagram" in the "Service" screen. If the voltage is zero when the output is activated, replace the Main board. WARNING: The output is controlled by a triac: a voltage can be read at the output, even when the triac is not open.
		The condenser solenoid valve (Yc) is not powered.	Connect a voltmeter to the terminals of the condenser solenoid valve (Ycond). Activate relay output S18 from "Outlets diagram" in the "Service" screen. If the voltage reads zero when the output is operated, check the solenoid valve cabling and repair as required.
		Condenser solenoid valve defective	Activate output S18 from "Outlets diagram" in the "Service screen". If the solenoid valve does not function, then replace.
		Cleaning box water level control failure	Check the operation of the "BnL" water level control from the "Inlets diagram" in the "Service" screen: if water is present, BnL = 1; if the probe is out of the water, BnL = 0. If this is not the case, check the condition of the probe (limescale, dirt) and its electrical connection. If the probe is working, replace the Main board.
E21	Cleaning box drainage pump fault	24/230Vac supply voltage input fault	With a voltmeter, check the supply voltage between input 24/230Vac of the Main board and terminal "Xb". This voltage should be 120V on ovens. If not, find the cause of the fault and repair as required.
		Fuse F4 blown (LED "702" off (► LEDs identification))	Find the cause of blowing, check the state of the descaling pump (Mdg) and the cavity drainage pump (Mvm). Repair by replacing the fuse with the same model.
		Fault with the Main board switch S05	Connect a voltmeter between the terminal S05 of the Main board and terminal Xb. Activate relay output S05 from "Outlets diagram" in the "Service" screen. If the voltage reads zero when the relay is operated, replace the Main board.
		The drainage pump is not powered	Connect a voltmeter to the terminals of the cavity drain pump (Mvm). Activate relay output S05 from "Outlets diagram" in the "Service" screen. If the voltage reads zero when the relay is operated, check the pump cabling and repair as required.
		Cleaning box drainage pump defective or blocked	Activate relay output S05 from "Outlets diagram" in the "Service" screen. If the pump does not function, visually check its state: clean or swap out as required.
		Cleaning box water level control failure	Check the operation of the "BnL" water level control from the "Inlets diagram" in the "Service" screen: if water is present, BnL = 1; if the probe is out of the water, BnL = 0. If this is not the case, check the condition of the probe (limescale, dirt) and its electrical connection. If the probe is working, replace the Main board.
E22	Descaling pump cartridge fault.	24/230Vac supply voltage input fault	With a voltmeter, check the supply voltage between input 24-/230Vac of the Main board and terminal "Xb". This voltage should be 120V. If not, find the cause of the fault and repair as required.
		Fuse F4 blown (LED "702" off (► LEDs identification))	Find the cause of blowing check the state of the Steam generator drainage pump (Mvg) and the cavity drainage pump (Mvm). Repair by replacing the fuse with the same model.
		Fault with the Main board switch S04	Connect a voltmeter between the terminal S04 of the Main board and terminal Xb. Activate relay output S05 from "Outlets diagram" in the "Service" screen. If the voltage reads zero when the relay is operated, replace the Main board.
		The descale pump is not powered	Connect a voltmeter to the terminals of the descaling pump (Mdg). Activate relay output S04 from "Outlets diagram" in the "Service" screen. If the voltage reads zero when the relay is operated, check the pump cabling and repair as required.
		Descaling tank drainage pump defective or blocked	Activate relay output S04 from "Outlets diagram" in the "Service" screen. If the pump does not function, visually check its state: clean or swap out as required.
		Steam generator water level control failure	Check the operation of the "BnC" water level control from the "Inlets diagram" in the "Service" screen: if water is present, BnC = 1; if the probe is out of the water, BnC = 0. If this is not the case, check the condition of the probe (limescale, dirt) and its electrical connection. If the probe is working, replace the Main board.
E23	Cleaning pump fault	230Vac supply voltage input fault	With a voltmeter, check the supply voltage between input 230Vac of the Main board and terminal "Xb". This voltage should be 230V. If not, find the cause of the fault and repair as required.
		Fuse F2 of the main board blown (LED "702" off (► LEDs identification))	Find the cause of blowing, check the status of the cleaning pump (Mpn) and the solenoid valves for the hand shower (Yspray) and/or descaling box filling (Ydescal.). Carry out repairs and replace the fuse with the same model.
		Fault with the Main board switch S13	Connect a voltmeter between the terminal S13 of the Main board and terminal Xb. Activate relay output S13 from "Outlets diagram" in the "Service" screen. If the voltage reads zero when the relay is operated, replace the Main board.
		The cleaning pump is not powered	Connect a voltmeter to the terminals of the cleaning pump (Mpn). Activate relay output S13 from "Outlets diagram" in the "Service" screen. If the voltage reads zero when the relay is operated, check the pump cabling and repair as required.

Code	Title	Probable Causes	What to do?
		Cleaning pump defective or blocked	Activate relay output S13 from "Outlets diagram" in the "Service" screen. If the pump does not function, visually check its state: clean or swap out as required.
		Clean wash box water level control failure	Check the water level control function from "Inlets diagram" in the "Service" screen: if the probe is in the water, the BnL = 1, and if it is out of the water, the BnL = 0. If this is not the case, check the condition of the probe (scale; dirt) and its electrical connection. If the probe is functional, replace the Main board.
		Cleaning pump capacitor faulty or incorrectly connected	Check cleaning pump capacitor connection (lugs well plugged in and no traces of oxidation). Switch off the oven, disconnect the capacitor and connect a multi-meter in its place to check the capacity of the 6.3µf (+/-5%) capacitor. If the value is incorrect, replace the capacitor.
E30	Unpricked Core probe or Failed Core Probe.	Check fault on the "Inlets diagram"	Open "Inlets diagram" in the "Service" screen and check the temperature being indicated by the food probe "Bsc". If the value is "---" at all points, the common point of the probe (Bsc com) is faulty (either short-circuited or open).
		Wire broken in probe or input connection Bsc Com	Disconnect the probe Pt100 from the Main board and take readings using an ohmmeter between points Bsc com and Bsc1, Bsc2 and Bsc3; If the circuit is broken, repair the connection. If not, replace the probe.
		Short circuit in the probe or probe input connection Bsc Com	Disconnect the probe Pt100 from the Main board and take readings using an ohmmeter between points Bsc com and Bsc1, Bsc2 and Bsc3; If there is a short circuit, locate the fault and repair as required. If not, replace the probe.
		Main board electrical fault	If the probe and the connections are functioning, replace the Main board.
		The extension lead between the Main board and the probe is faulty	Check the ohmic values of each PT100 probe: measure the values between the common (yellow wire) and each of the other wires, compare the values with the values (see chapter PT100 Probe). Carry out this operation on the probe side and on the board side. If the values differ, replace the extension lead between the probe and the Main board.
E31	Food probe degraded.	Check fault on the "Inlets diagram"	Open "Inlets diagram" in the "Service" screen and check the temperature being indicated by the food probe "Bsc". If one of the values is "---", this point of the probe (Bsc1 => Bsc3) is faulty (either short-circuited or open).
		Wire broken in probe or the input connections Bsc 1 to 3	Disconnect the probe Pt100 from the Main board and take readings using an ohmmeter between points Bsc com and Bsc1, Bsc2 and Bsc3; If one of the test points is broken, repair the connection. If not, replace the probe.
		Short circuit in the probe or one of the probe input connections Bsc 1 to 3	Disconnect the probe Pt100 from the Main board and take readings using an ohmmeter between points Bsc com and Bsc1, Bsc2 and Bsc3; If one of the test points has short circuited, repair the connection. If not, replace the probe.
		Main board electrical fault	If the probe is functioning, replace the Main board.
		The extension lead between the Main board and the probe is faulty	Check the ohmic values of each PT100 probe: measure the values between the common (yellow wire) and each of the other wires, compare the values with the values (see chapter PT100 Probe). Carry out this operation on the probe side and on the board side. If the values differ, replace the extension lead between the probe and the Main board.
E32	Food probe not inserted.	Probe not inserted in food, incorrect measurement values	Insert the food probe, taking care to follow the instructions of pricking.
E34	USB Core Probe unpricked or out of service.	The probe is detected at the USB port but temperature is not being measured.	Open "Inlets diagram" in the "Service" screen and check the temperature being indicated by the food probe "USB". If the value is "---" at all points, the probe is defective. Replace the probe.
E35	USB food probe degraded.	One or more of the measured temperatures are out of range.	Open "Inlets diagram" in the "Service" screen and check the temperature being indicated by the food probe "USB". If the value is "---" at one of the measuring points, the probe is defective. Replace the probe.
E40	Gas safety device active on "convection" cavity burner.	Gas inlet valve closed, no gas or Incorrect gas type	Make sure that the gas supply is on. Check that the type of gas being supplied conforms with that shown on the appliance's specification plate. Open the gas valve
		No grounding on power supply	Check the grounding of the device using a megohmmeter. Check or have someone check the continuity of the ground and the grounding.
		Gas pressure too low	Measure the gas pressure by measuring from input of the gas valve "Pin" (▶ Changing/adjusting gas valve) at the appliance connection when all appliances running off the same supply are operating at maximum capacity. The gas pressure must be within the allowed limits.
		Gas board output AL12 defective	Connect a voltmeter between the terminal AL12 of the add-on gas board (Aag) and terminal Xb. Activate relay output AL12 from "Outlets diagram" in the "Service" screen. If the voltage reads zero when the relay is operated, replace the add-on gas board.
		The spark box Ear (▶ Electric boards) is not powered.	Connect a voltmeter to the terminals of the "convection" burner spark box Ear. Activate relay output AL12 from "Outlets diagram" in the "Service" screen. If the voltage reads zero when the relay is operated, check the lighter cabling and repair as required.

Code	Title	Probable Causes	What to do?
		The spark box Ear (▶ Electric boards) is defective.	Activate output relay AL12 from "Outlets diagram" in the "Service" screen. If the spark box Ear does not function, then replace.
		The gas board (Aag) is received a signal from the safety box "Avr1" on SECU12 input on the gas board "Aag".	Check if flame sensor is properly connected to the safety box "Avr1". If properly connected, replace the safety box "Avr1".
		Incorrect spacing of the gas flame sensor	Check the spacing of ignition electrodes and flame sensor.
		The input PF1 (or PF2 on oven 20N) of the gas add-on board is defective	Changing the add-on gas board (Aag)
E41	Gas safety device active on steam generator burner.	Gas inlet valve closed, no gas or incorrect gas type	Make sure that the gas supply is on. Check that the type of gas being supplied conforms with that shown on the appliance's specification plate. Open the gas valve
		No grounding on power supply	Check the grounding of the device using a megohmmeter. Check or have someone check the continuity of the ground and the grounding.
		Gas pressure too low	Measure the gas pressure by measuring from input of the gas valve "Pin" (▶ Changing/adjusting gas valve) at the appliance connection when all appliances running off the same supply are operating at maximum capacity. The gas pressure must be within the allowed limits. If not, adjust the gas pressure or increase the capacity of the gas supply (Expansion valve, pipe diameter).
		Gas board AL3 output defective	Connect a voltmeter between the terminal AL3 of the add-on gas board (Aag) et une terminal Xb. Operate the output relay AL3 from "Outlets diagram" in the "Service" screen. If the voltage reads zero when the relay is operated, replace the add-on gas board.
		The spark box Eag (▶ Electric boards) is not powered.	Connect a voltmeter to the terminals of the Steam generator burner spark box Eag. Operate the output relay AL3 from "Outlets diagram" in the "Service" screen. If the voltage reads zero when the relay is operated, check the lighter cabling and repair as required
		The spark box Eag (▶ Electric boards) is defective.	Activate relay output AL3 from "Outlets diagram" in the "Service" screen. If the Steam generator burner spark box Eag does not function, then replace.
		The gas board (Aag) is received a signal from the safety box "Avg" on SECU3 input on the gas board "Aag".	Check if flame sensor is properly connected to the safety box "Avg". If properly connected, replace the safety box "Avg".
		Incorrect spacing of the gas flame sensor	Check the spacing of ignition electrodes and flame sensor.
		The input "PF3" of the gas add-on board is defective.	Changing the add-on gas board (Aag)
E50	Humidity sensor faulty (This error only appears when the oven is cooking not preheating).	Open "Inlets diagram" on the "Service" screen and check the humidity value delivered by the sensor. This must be greater than 3%. If this is not the case, check the following points:	
		The F2 fuse on the "Ahu" humidity additional board (▶ Humidity board) is blown, (LED 100 off (▶ LEDs identification))	Find the cause of the blowing and replace the fuse by the same model.
		The "Humidity" add-on board (Ahu) is not powered.	Check the flashing of the communication LED "green" and "orange" on the board. If they do not flash, use a voltmeter to check that the board is powered (Set to DC current). This must be +24Vdc
		The "Humidity" add-on board (Ahu) is not communicating with the Main board.	Check the flashing of the communication LED "green" and "orange" on the board. If they do not flash, change the add-on board
		The J2 connector on the Ahu "Humidity" additional board is not properly inserted into its socket, or the wires are not properly connected in the connector.	Check the connections on connector J2 of the AHU "Humidity" additional board, check that the connector screws are tight, and check that the extension connector is properly connected to the sensor connector.
		The humidity probe is defective	Check the status of the LEDs: if the "200" LED is flashing red or steady red, replace the humidity sensor (▶ Communication LEDs)
E60	Internal oven fan not functioning	Before resolving error E60, please refer to the "error history" on the "Service" screen and check that no other error codes are displayed. If any are displayed, correct these errors first.	
		The fuse "Ftmv" is blown	Find the cause of the blowing and replace by the fuse with the same model
		The fuse F3 of the Main board (▶ Main board) has blown (LED "701" off (▶ LEDs identification))	Find the cause of the blowing and replace by the fuse with the same model.
		The fuse Fm (located in the black cylindrical fuse holder near connector J22) of the Main board (▶ Main board) has blown (LED "801" off (▶ LEDs identification)) This LED lights only when the contactor Kp is on	Find the cause of the blowing and replace by the fuse with the same model.
		The fan motor thermal protection is open	POWER OFF, check the continuity of the circuit between the terminal A2 of the contactor Kp and terminal Xb. If the circuit is broken, check the cabling or change the motor.
		The main contactor Kp is not powered	Connect a voltmeter between the terminals A1 and A2 of the main contactor Kp. Activate relay output Kp from "Outlets diagram" in the "Service" screen. If the voltage reads zero when the relay is operated, check the contactor Kp cabling or replace the Main board.
		The main contactor Kp is defective	Connect a voltmeter between the terminals A1 and A2 of the main contactor Kp. Operate the output Kp from "Outlets diagram" in the "Service" screen. If the main contactor Kp does not close when powered, replace the contactor.

Code	Title	Probable Causes	What to do?
		The motor is not powered	POWER OFF: check the motor connector (it is properly engaged in the socket, the connections are secure, etc.). POWER ON: connect a voltmeter between the terminals Xm1 and Xm0. Operate the output switch Kp from "Outlets diagram" in the "Service" screen. If the voltage is not between 208V et 240V, inspect the cabling.
		Motor circuit cut	POWER OFF, check the continuity of the circuit between the outputs S22 and S23 of the Main board and the terminal Xm0. If the circuit is open (the measurement indicated is "OL"), check the cabling or change the fan motor.
		Short-circuited Triac motor	POWER OFF: measure the continuity between terminals E21 and S22 on the Main board. If they are short-circuited, the ohmmeter will indicate a value close to "0" Ω. If this is the case, replace the Main board.
	<i>To reset this fault, the power supply to the oven must be cut off by disconnecting the associated protection circuit breaker.</i>		
E70	Electronics overheat: temp. greater than or equal to 149°F.	Ambient temperature around oven too high	The oven is not getting enough fresh air: clean the air intake vents (► Location of technical components), check the installation, and move any appliances that generate a lot of heat, such as open burners or hot plates, away from the oven. It may be necessary to install an optional heat shield.
		Air inlets require cleaning	Clean the cool air intake vents
		Technical fan(s) require(s) cleaning	Clean the technical fan(s)
		The fuse F3 of the Main board (► Main board) has blown (LED "701" off (► LEDs identification))	Find the cause of blowing and replace with fuse of the same model.
		The output S08 in J16 connector of the Main board is defective.	Connect a voltmeter between the terminal S08 of Main board and a Xb terminal. Activate relay output S08 from "Outlets diagram" in the "Service" screen. If there is no voltage, replace the Main board.
		In electrical oven only, the output S091 in J16 connector of the Main board is defective.	Connect a voltmeter between the terminal S091 of Main board et a Xb terminal. Activate relay output S091 from "Outlets diagram" in the "Service" screen. If there is no voltage, replace the Main board.
		The technical fan(s) is (are) not powered	Connect a voltmeter between the terminals ventilator power supply. Activate relay output S08 from "Outlets diagram" in the "Service" screen. If the voltage reads zero, inspect the cabling. On electric's ovens only, do the same operation with the S091 output. From "Outlets diagrams in the "Service" screen, activate Kp, if the voltage between the terminal fan connexions is "0"V, check the wiring.
	The technical fan(s) is defective	Activate relay output S08 from "Oven diagram" in the "Service" screen. If the fan does not turn, then replace. On electric ovens only, activate output S091 by pressing on "Kp" from "Outlets diagram" in "Service" screen then the second fan must run. If it does not turn, replace it.	
E71	Electronics overheat: temp. greater than or equal to 158°F.	Ambient temperature around oven too high	The oven is not getting enough fresh air: clean the air intake vents (► Location of technical components), check the installation, and move any appliances that generate a lot of heat, such as open burners or hot plates, away from the oven. It may be necessary to install an optional heat shield.
		Air inlets require cleaning	Clean the cool air intake vents.
		Technical fan(s) require(s) cleaning	Clean the technical fan(s).
		The fuse F3 of the Main board (► Main board) has blown (LED "701" off (► LEDs identification))	Find the cause of blowing and replace with fuse of the same model.
		The output S08 in J16 connector of the Main board is defective.	Connect a voltmeter between the terminal S08 of Main board and a Xb terminal. Activate relay output S08 from "Outlets diagram" in the "Service" screen. If there is no voltage, replace the Main board.
		In electrical oven only, the output S091 in J16 connector of the Main board is defective.	Connect a voltmeter between the terminal S091 of Main board et a Xb terminal. Activate relay output S091 from "Outlets diagram" in the "Service" screen. If there is no voltage, replace the Main board.
		The technical fan(s) is (are) not powered	Connect a voltmeter between the terminals ventilator power supply. Activate relay output S08 from "Outlets diagram" in the "Service" screen. If the voltage reads zero, inspect the cabling. On electric's ovens only, do the same operation with the S091 output. From "Outlets diagrams in the "Service" screen, activate Kp, if the voltage between the terminal fan connexions is "0"V, check the wiring.
	The technical fan(s) is defective	Activate relay output S08 from "Oven diagram" in the "Service" screen. If the fan does not turn, then replace. On electric ovens only, activate output S091 by pressing on "Kp" from "Outlets diagram" in "Service" screen then the second fan must run. If it does not turn, replace it.	
E72	Electronics overheat: temp. greater than or equal to 167°F.	Ambient temperature around oven too high	The oven is not getting enough fresh air: clean the air intake vents (► Location of technical components), check the installation, and move any appliances that generate a lot of heat, such as open burners or hot plates, away from the oven. It may be necessary to install an optional heat shield.
		Air inlets require cleaning	Clean the cool air intake vents
		Technical fan(s) require(s) cleaning	Clean the technical fan(s)
		The fuse F3 of the Main board (► Main board) has blown (LED "701" off (► LEDs identification))	Find the cause of blowing and replace with fuse of the same model.
		The output S08 in J16 connector of the Main board is defective.	Connect a voltmeter between the terminal S08 of Main board and a Xb terminal. Activate relay output S08 from "Outlets diagram" in the "Service" screen. If there is no voltage, replace the Main board.
		In electrical oven only, the output S091 in J16 connector of the Main board is defective.	Connect a voltmeter between the terminal S091 of Main board et a Xb terminal. Activate relay output S091 from "Outlets diagram" in the "Service" screen. If there is no voltage, replace the Main board.

Code	Title	Probable Causes	What to do?
		The technical fan(s) is (are) not powered	Connect a voltmeter between the terminals ventilator power supply. Activate relay output S08 from "Outlets diagram" in the "Service" screen. If the voltage reads zero, inspect the cabling. On electric's ovens only, do the same operation with the S091 output. From "Outlets diagrams in the "Service" screen, activate Kp, if the voltage between the terminal fan connexions is "0"V, check the wiring.
		The technical fan(s) is defective	Activate relay output S08 from "Oven diagram" in the "Service" screen. If the fan does not turn, then replace. On electric ovens only, activate output S091 by pressing on "Kp" from "Outlets diagram" in "Service" screen then the second fan must run. If it does not turn, replace it.
E75	Screen electronic (SoM) temperature above 176°F. The temperature of the electronics has exceeded its critical operating threshold. The oven can no longer operate.	Ambient temperature around oven too high	The oven is not getting enough fresh air: clean the air intake vents (▶ Location of technical components), check the installation, and move any appliances that generate a lot of heat, such as open burners or hot plates, away from the oven. It may be necessary to install an optional heat shield.
		Air inlets require cleaning	Clean the cool air intake vents
		Technical fan(s) require(s) cleaning	Clean the technical fan(s)
		The fuse F3 of the Main board (▶ Main board) has blown (LED "701" off (▶ LEDs identification))	Find the cause of blowing and replace with fuse of the same model.
		The output S08 in J16 connector of the Main board is defective.	Connect a voltmeter between the terminal S08 of Main board and a Xb terminal. Activate relay output S08 from "Outlets diagram" in the "Service" screen. If there is no voltage, replace the Main board.
		In electrical oven only, the output S091 in J16 connector of the Main board is defective.	Connect a voltmeter between the terminal S091 of Main board et a Xb terminal. Activate relay output S091 from "Outlets diagram" in the "Service" screen. If there is no voltage, replace the Main board.
		The technical fan(s) is (are) not powered	Connect a voltmeter between the terminals ventilator power supply. Activate relay output S08 from "Outlets diagram" in the "Service" screen. If the voltage reads zero, inspect the cabling. On electric's ovens only, do the same operation with the S091 output. From "Outlets diagrams in the "Service" screen, activate Kp, if the voltage between the terminal fan connexions is "0"V, check the wiring.
		The technical fan(s) is defective	Activate relay output S08 from "Oven diagram" in the "Service" screen. If the fan does not turn, then replace. On electric ovens only, activate output S091 by pressing on "Kp" from "Outlets diagram" in "Service" screen then the second fan must run. If it does not turn, replace it.
E76	Screen electronic (SoM) temperature above 194°F. The temperature of the electronics has exceeded its critical operating threshold. The oven can no longer operate.	Ambient temperature around oven too high	The oven is not getting enough fresh air: clean the air intake vents (▶ Location of technical components), check the installation, and move any appliances that generate a lot of heat, such as open burners or hot plates, away from the oven. It may be necessary to install an optional heat shield.
		Air inlets require cleaning	Clean the cool air intake vents
		Technical fan(s) require(s) cleaning	Clean the technical fan(s)
		The fuse F3 of the Main board (▶ Main board) has blown (LED "701" off (▶ LEDs identification))	Find the cause of blowing and replace with fuse of the same model.
		The output S08 in J16 connector of the Main board is defective.	Connect a voltmeter between the terminal S08 of Main board and a Xb terminal. Activate relay output S08 from "Outlets diagram" in the "Service" screen. If there is no voltage, replace the Main board.
		In electrical oven only, the output S091 in J16 connector of the Main board is defective.	Connect a voltmeter between the terminal S091 of Main board et a Xb terminal. Activate relay output S091 from "Outlets diagram" in the "Service" screen. If there is no voltage, replace the Main board.
		The technical fan(s) is (are) not powered	Connect a voltmeter between the terminals ventilator power supply. Activate relay output S08 from "Outlets diagram" in the "Service" screen. If the voltage reads zero, inspect the cabling. On electric's ovens only, do the same operation with the S091 output. From "Outlets diagrams in the "Service" screen, activate Kp, if the voltage between the terminal fan connexions is "0"V, check the wiring.
		The technical fan(s) is defective	Activate relay output S08 from "Oven diagram" in the "Service" screen. If the fan does not turn, then replace. On electric ovens only, activate output S091 by pressing on "Kp" from "Outlets diagram" in "Service" screen then the second fan must run. If it does not turn, replace it.
E80	Communication fault between boards.	Degraded communications cable	Replace the communication cable between Main board "Ar" and Interface board "Ai". If the problem persists, check electronics boards.
		Defective electronic boards	Test and replace the faulty electronic board(s) following the procedure (▶ Replacing electronic boards).
E81	Break in communication between circuit boards.	Degraded communications cable	Replace the communication cable between Main board "Ar" and Interface board "Ai". If the problem persists, check electronics boards.
		Defective Main boards	Test and replace the faulty electronic board(s) following the procedure (▶ Replacing electronic boards).
		<i>To reset this fault, the power supply to the oven must be cut off by disconnecting the associated protection circuit breaker.</i>	
E82	SD Card fault.	SD card corrupted	Replace the SD card as described in the first chapter of this document (▶ Replacing electronic boards).
E83	Cloud error.	The network is inaccessible	Restore access to the Ethernet or WiFi network
		Is the network cable connected correctly?	Check the connection to the RJ45 socket on the screen board, check or have checked the condition of the cable using a network cable tester, replace the cable if necessary.

Code	Title	Probable Causes	What to do?
		The wifi dongle key is incorrectly connected or faulty	Check that the Wifi dongle key is connected to the USB socket, check that the Wifi dongle key is working properly and replace it if necessary.
		The screen board is faulty	Replace the screen board following the procedure (▶ Replacing electronic boards).
E90	Steam generator fault (E11,12,13,14,15) during cycle.	A fault E11,12,13,14,15 appeared and remained for more than 3 minutes, triggering the TWIN CONTROL and automatically switching to Convection mode.	Check the error history to identify the original error and potential causes.
E91	Steam generator fault (E11,12,13,14,15) during cleaning.	A fault E11,12,13,14,15 appeared and remained for more than 3 minutes, triggering the TWIN CONTROL and removing the steam phases.	Check the error history to identify the original error and potential causes.
E92	Humidity sensor fault (E50).	A fault E11,12,13,14,15 appeared and remained for more than 3 minutes, triggering the TWIN CONTROL and removing the steam phases.	Check the error history to identify the original error and potential causes.
E93	Core probe fault (E30, E34).	A fault E130, E34 appeared and remained for more than 3 minutes, triggering the TWIN CONTROL and removing the steam phases.	Check the error history to identify the original error and potential causes.
E94	Fault preventing washing.	A fault E00, 02, 14, 60, 81 appeared and remained for more than 3 minutes, triggering TWIN CONTROL and cancelling the clean sequence.	Check the error history to identify the original error and potential causes.
I98	Started with Remaining Water Treatment Capacity at 0.	The water treatment system has reached its maximum treatment capacity	Carry out or arrange for maintenance of the water treatment system
I99	Started with Number of days before service < 0.	The maintenance frequency has been reached or exceeded.	Contact the technical department to arrange preventive maintenance
i100	Gas Control: Speed control of a gas fan done successfully.	During preventive maintenance or any other operation requiring this check, it has been carried out successfully, the fan speed in ignition mode does not exceed +/- 20% of the setpoint value on average.	No intervention
E101	Gas Control: Speed control of a gas fan, with speed drift/ speed issue.	During preventive maintenance or any other operation requiring this control, the fan speed in ignition mode exceeds +/- 20% of the setpoint value on average.	Check rotating motor, no suspicious noises, replace gas board
E102	Gas Control: Speed control of a gas fan made, with acquisition issue.	During preventive maintenance or any other operation requiring this control, the Aag gas board does not detect the return of the speed setpoint.	Check fan motor wiring, i.e. correct connection of speed feedback connector, correct connection of connector on gas board, wiring between these two elements, if correct, replace motor.
i103	Gas Control: Control of a burner done, with rapid ignition, OK.	If the average ignition time is less than or equal to 9 seconds.	No intervention
E104	Gas Control: Control of a burner done, with average ignition but OK.	If the average ignition time is greater than 9 seconds and less than or equal to 19.5 seconds.	A word of caution: plan a thorough check during the next preventive maintenance cycle.
E105	Gas Control: Control of a burner done, with ignition OK but difficult.	If average ignition time is greater than 19.5 seconds and less than or equal to 30 seconds.	Check burner ignition line, gas pressure at time of sequence, condition of valve and spark box if ok disassemble burner and readjust ignition electrodes.
E106	Gas Control: Control of a burner done, with ignition OK but very problematic.	If the average ignition time is greater than 30 seconds and less than or equal to 51 seconds.	Disassemble burner adjust or replace electrodes
E107	Gas Control: Ignition failed. Safety activated.	If average ignition time is greater than 51 seconds.	See error E40 or E41
E108	The grease collection is stopped.	The grease collection valve is closed.	Open the valve.
		The pressure switch is defective	From "Hydraulics diagram" in the "Service" screen, check the state of the E1 input. If the button lights up in yellow, the contact is open then check there is no overpressure, check the wiring, and if the problem persists, replace the pressure switch. Be careful, the pressure switch is setting by the builder, never modify the set.
		The circuit is blocked	Check the grease flows properly, if problem, clean the circuit and/or replace the defective elements.

5.3 MAINTENANCE SCREENS

After taking into account the information provided by the customer, and if no error message is displayed on the screen, activate the diagnostic help module, which consists of 3 separate screens.

Help function checks the board's inputs and outputs, as well as the associated peripheral components:

- Screen 1 "Inlets Diagram" check inputs: temperatures, doors, water level, humidity, etc...
- Screen 2 "Outlets Diagram", comprising two screens, controls outputs: ventilation, heating, lighting, safety contactor, technical ventilation, IN valve, etc.
- Screen 3 "Hydraulics diagram" controls hydraulics outputs: water solenoid valves, cleaning pump, drain pump, descaling pump...

You can navigate between the various diagrams using the display area at the bottom of the screen, accessible from any of the 4 screens of the diagnostic assistance module.

5.3.1 INLETS STATUS SCREEN

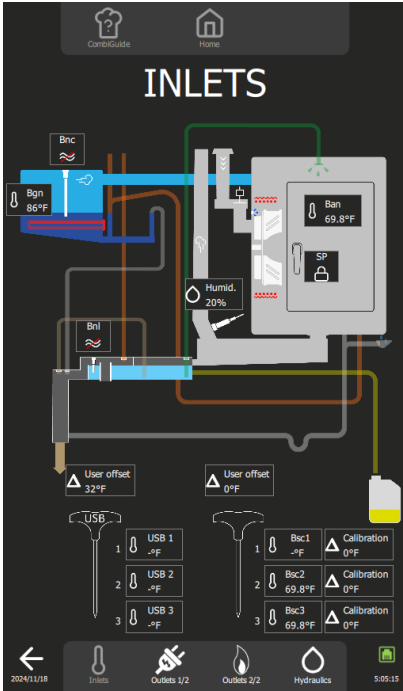

Inputs	Normal status	Remarks
Ban	Cooking cavity temperature	-
Sp	Door position	Padlock closed = door closed Padlock open = door open
Bnl	Cleaning box level	Red line through symbol = no water
Bnc	Steam generator water level	Red line through symbol = no water
Bgn	Steam generator temperature	-
Bsc1...3	Core probe temperature	-
Humid.	Humidity rate	-

5.3.2 OUTLETS STATUS SCREEN

This screen is divided into 2 screens: Outlets 1/2 and Outlets 2/2.

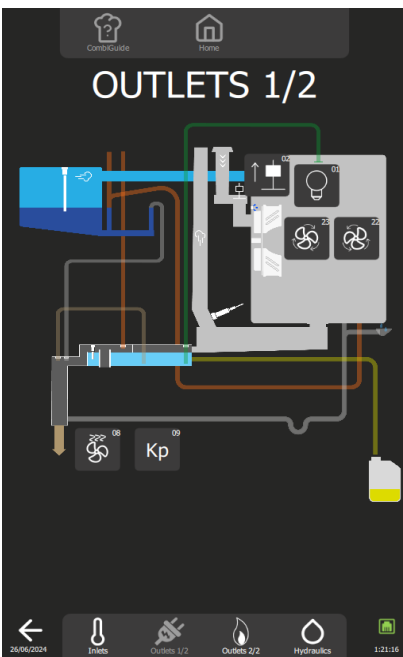

Screen 1/2

Pressing a button activates a timer, the duration of which may vary according to the element being controlled. This time delay can be cancelled by pressing the same button again.

No. Outlet	Components	Operating
01	Leds lighting	1 press on the button activates the lighting for 60s
02	In flapper motor	1 press on the button activates the flapper for 60s
08	Technical fan	1 press on the button activates the fan for 5s
09	Safety contactor	1 press on the button activates the contactor for 1s
22	Turbine (clockwise)	1 press on the button activates the turbine for 5s
23	Turbine (counterclockwise)	1 press on the button activates the turbine for 5s



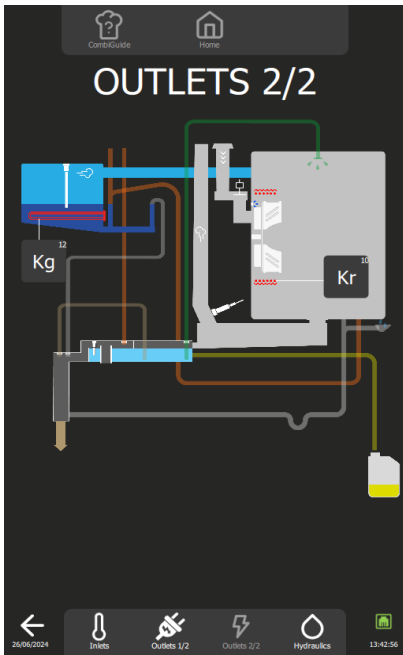

Screen 2/2: Electric ovens

Pressing a button activates a timer, the duration of which may vary according to the element being controlled. This time delay can be cancelled by pressing the same button again.

No. Outlet	Components	Operating
10	Heating contactor	1 press on the button activates the contactor for 1s
12	Steam generator contactor	1 press on the button activates the contactor for 1s

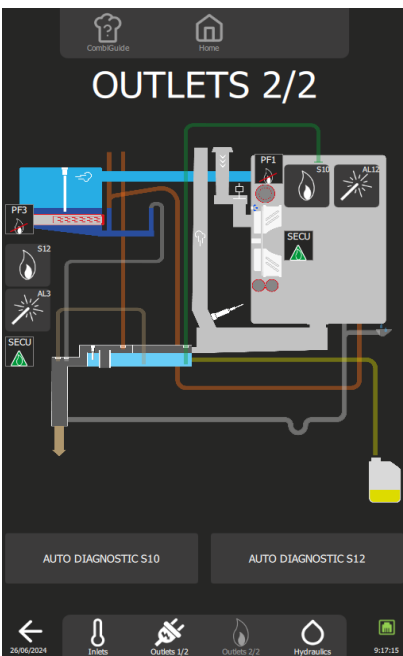

Screen 2/2: Gas ovens

Pressing a button activates a timer, the duration of which may vary according to the element being controlled. This time delay can be cancelled by pressing the same button again.

No. Outlet	Components	Operating
AL12	Ignitor	1 press on the button, activates the spark box for 5s
AL3	Steam generator spark box	1 press on the key, activates the spark box for 5s
PF1	Burner 1 flame present	Crossed out: flame absent Not crossed out: flame present
PF2	Burner 2 flame present	Crossed out: flame absent Not crossed out: flame present
PF3	Burner 3 flame present	Crossed out: flame absent Not crossed out: flame present
S10	Outlet S10	1 press on the button activates outlet for 10s
S11	Outlet S11	1 press on the button activates outlet for 10s
S12	Outlet S12	1 press on the button activates outlet for 10s
SECU	Safety	Green: not active Red: active

Procedure for checking the operation of the gas heater: presence of a flame in the burner (S10 - S11 or S12)

- During the preventive maintenance visit, or in order to check the burners BEFORE removing them, you can use TWO TOOLS on this screen:
- The S10 / S11 / S12 burner buttons (number of burners depending on the model): Each button will attempt to ignite the burner, resulting in correct ignition and flame detection (the corresponding PFx icon is no longer crossed out), or in a safety shutdown (the associated SECU label changes to red).
 - The « AUTO DIAGNOSTIC S10, S11 and S12 » buttons : These buttons are used to check that the gas burner fans are operating correctly and then to make a real evaluation of the ignition quality. Even if ignition takes place, the quality will be assessed on 4 levels, from Fast (perfect), to Problematic, to Medium and Difficult. Depending on the rating, it will not be necessary to remove the burner to check the electrodes and burners.

Using the S10 / S11 / S12 burner buttons

- » Press button S10 or S11 (depending on the model) or S12 (depending on the type of burner to be tested) to activate the burner concerned.
 - ⌚ For 10 seconds, outlets Ar-10 / Ar-11 or Ar-12 on the Main board closes, as well as outlets Ar-081 and Ar-09. This causes the relay on the gas board to close, initiating an ignition cycle.
- » If this fails, try again.
 - ⌚ If the PF1 / PF2 or PF3 sticker is no longer crossed out, and the associated SECU sticker stays green, this indicates that the system is operating correctly.
 - Check the heating elements (spark box, gas board, etc.). (► [Troubleshooting](#))
- » If another failure occurs, make a third attempt.
 - ⌚ If the PF1 / PF2 or PF3 sticker is crossed out, and the associated SECU sticker changes to red, this indicates that the system isn't operating correctly.



- Dismantle the burner and clean and/or adjust the electrodes in accordance with the instructions in this manual. (▶ Electrode inspection). (▶ [Control of the electrodes](#))

Using the “S10 / S11 / S12 auto-diagnostic” buttons

In progress

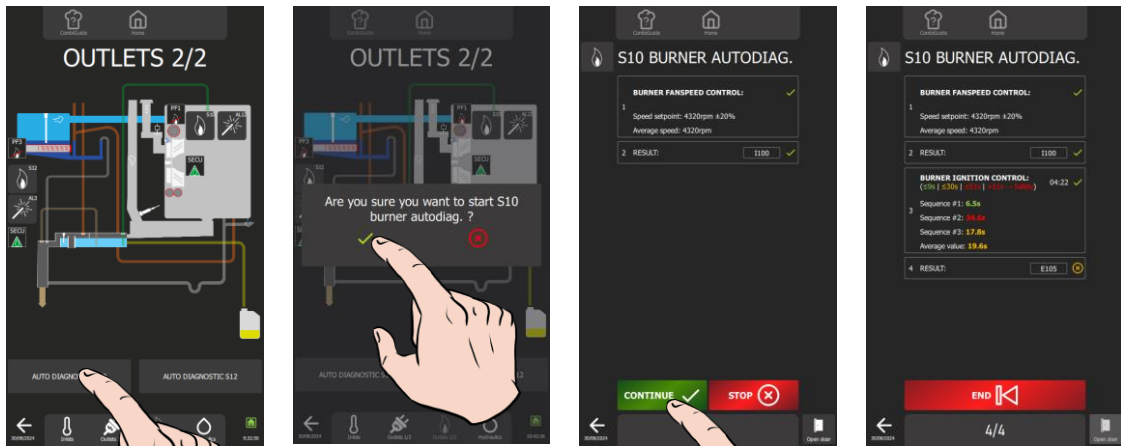

- » Pressing the AUTO DIAGNOSTIC button S10 or S11 (depending on the model) or S12 (depending on the type of burner to be tested) activates the burner self-diagnosis module.

5.3.3 HYDRAULIC DIAGRAMS

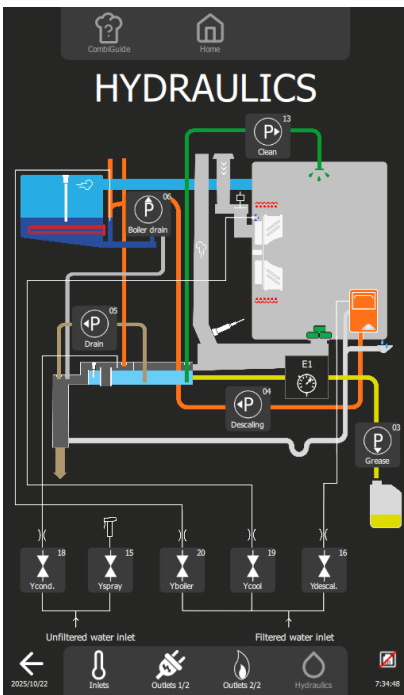

Pressing a button activates a timer, the duration of which may vary according to the element being controlled. This time delay can be cancelled by pressing the same button again.

No. Outlet	Components	Operating
P - 13	Cleaning pump	1 press on the button activates the pump for 5s
P - 06	Steam generator drain pump	1 press on the button activates the pump for 5s
P - 05	Cleaning box drain pump	1 press on the button activates the pump for 5s
P - 04	Descaling pump	1 press on the button activates the pump for 5s
P - 03	Grease collection pump (optional)	1 press on the button activates the pump for 5s
Ycond. - 18	Condenser solenoid valve	1 press on the button activates the solenoid valve for 60s
Yspray - 15	Spray solenoid valve	1 press on the button activates the solenoid valve for 60s
Ysteam generator - 20	Steam generator solenoid valve	1 press on the button activates the solenoid valve for 60s
Ycool - 19	Cooling solenoid valve	1 press on the button activates the solenoid valve for 60s
Ydescal. - 16	Descaling solenoid valve	1 press on the button activates the solenoid valve for 60s

No. Inlet	Components	Operating
E1	Pressure switch Grease collection (optional)	Normally closed, opens if there is excess pressure in the circuit



5.4 COMMUNICATIONS LEDS

5.4.1 LEDS IDENTIFICATION

Main board, humidity board

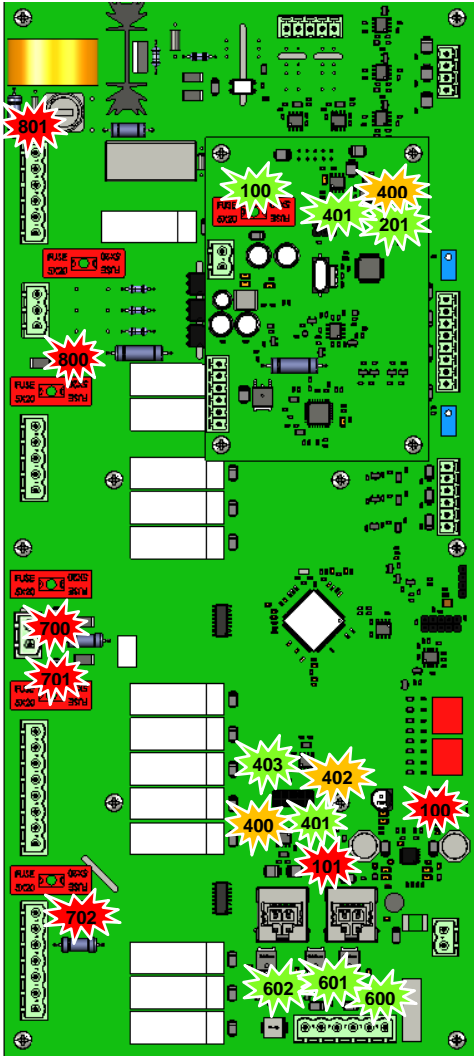

Main board

LED	Colour	Status	Designation
100	Red	On - Permanent	3.3 Volt voltage present
101	Red	On - Permanent	5 Volt voltage present
400	Orange	Flashing	Tx signals RS485 communication
401	Green	Flashing	Tx signals RS485 communication
402	Orange	Flashing	Tx signals RS485 communication
403	Green	Flashing	Tx signals RS485 communication
600	Green	On - Permanent	Outlet S1 switched on
601	Green	On - Permanent	Outlet S2 switched on
602	Green	On - Permanent	Outlet S3 switched on
700	Red	On - Permanent	Fuse F2 OK
701	Red	On - Permanent	Fuse F3 OK
702	Red	On - Permanent	Fuse F4 OK
800	Red	On - Permanent	Fuse F1 OK
801	Red	On - Permanent	Lighting if activated Kp. Fuse Fm OK

Humidity board

LED	Colour	Status	Designation
100	Green	On - Permanent	Fuse F1 OK
200	Green	Flashing then Off	Indicates uncorrect operation of the humidity sensor
201	Green	Flashing then Permanent	Indicates correct operation of the humidity sensor
400	Orange	Flashing	RS485 communication Tx signals - Transmit
401	Green	Flashing	RS485 communication Rx signals - Reception

Gas board

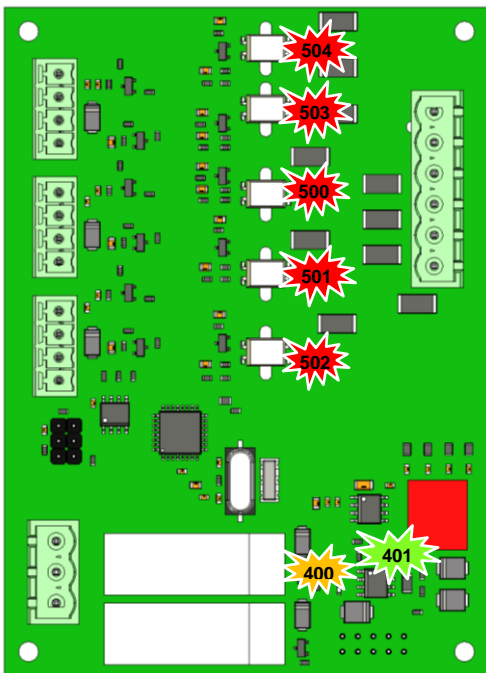

LED	Colour	Status	Designation
400	Orange	Flashing	Tx signals RS485 communication
401	Green	Flashing	Tx signals RS485 communication
500	Red	Permanent	Presence of gas in the gas steam generator burner
501	Red	Permanent	Presence of gas in convection heater burner 2 (on certain models only)
502	Red	Permanent	Presence of gas in convection heater burner 1
503	Red	Permanent	Gas safety fault - steam generator burner
504	Red	Permanent	Gas safety fault - convection heat burner





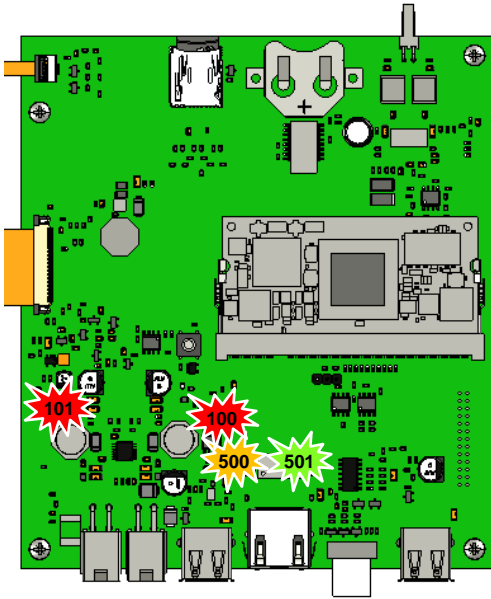

Interface board



LED	Colour	Status	Designation
100	Red	On - Permanent	3.3 Volt voltage present
101	Red	On - Permanent	5 Volt voltage present
500	Orange	On - Permanent	Tx signals RS485 communication
501	Green	On - Permanent	Tx signals RS485 communication

5.4.2 OPERATION: COMMUNICATION

Legends

LED	Meaning
	Green - Receiving
	Orange - Transmitting
	Red - Power on
	LED off



Communication LEDs Main board and Interface board

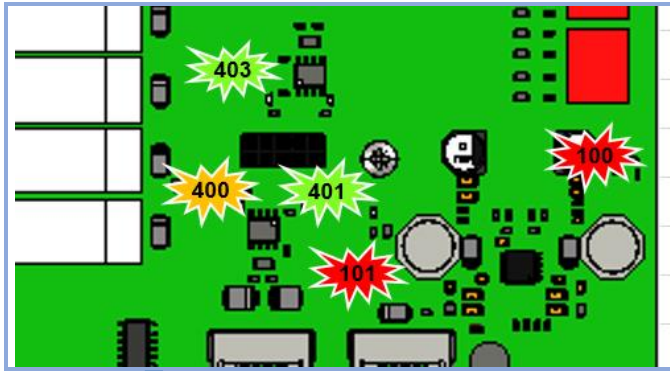

Ai Interface Board				Aa Main board				Diagnostics	Solutions
101	100	500	501	400	401	101	100		
●	●	●	●	●	●	●	●	Aa and Ai board - OK	Functioning normally
●	●	●	●	●	●	●	●	Power supply failure	Check for 24 Vd.c. at the terminals of J18
●	●	●	●	●	●	●	●	Connection problem with Ai board	Replace interconnecting cable between Ar and Ai board, and/or Ai board
●	●	●	●	●	●	●	●	Aa board - Out of order	Replace the Aa board
●	●	●	●	●	●	●	●	Ai board - Out of order	Replace Ai board
●	●	●	●	●	●	●	●	Interconnecting Cable between Ai board and Aa assembly faulty	Replace interconnecting cable

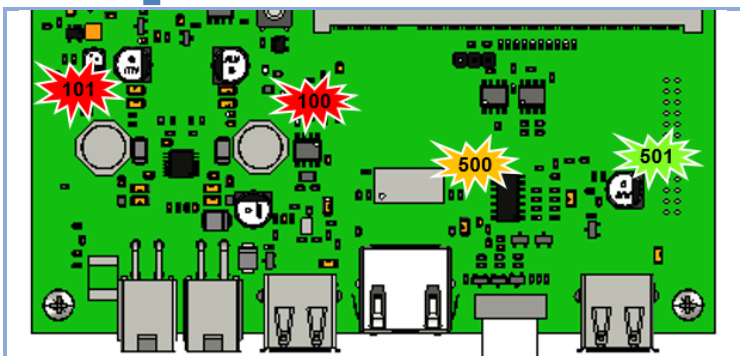

Communication LEDs Gas board

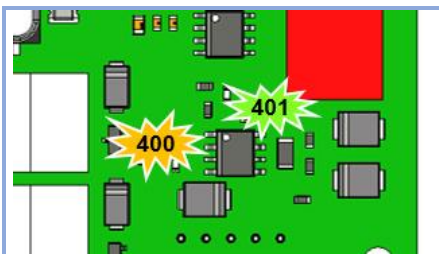

Gas board Aag		Diagnostics	Solutions
400	401		
●	●	Aag board - OK	Functioning normally
●	●	Aag board - Out of order	Replace the board



Communication LEDs Humidity board

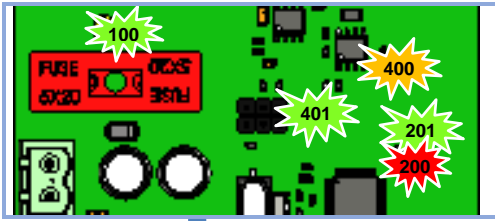

Humidity board Ahu		Diagnostics	Solutions
401	400		
		Ahu board - OK	Functioning normally
		Ahu board - Out of order	Replace the board

Humidity board Ahu		Diagnostics	Comments
201	201		
		Standby	
		Initialization	Flashes - Start-up or wake-up from standby.
		Start-up calibration	Alternating flashes.
		Initial heating ramp on heater	Blinking proportional to heating percentage.
		Heater temperature within control range	Normal functioning.
		Heater overheating	Flashing.
		Other errors	<ul style="list-style-type: none"> - Ar communication error - CJ125 calibration error - Supply voltage too low - Humidity sensor missing or incorrectly connected - Heater probe current zero.



5.5 OTHER SYMPTOMS

All electrical measurements must be carried out in compliance with local legislation (personnel authorization, use of PPE, etc.).
OFF-VOLTAGE tests must absolutely be carried out in this configuration. Make sure you carry out these tests safely (consignment, etc.).

SYMPTOM	CAUSE	WHAT TO DO?
The oven is not working the display is off.		
	- Supply voltage is not present at the device terminals.	Check condition of the power cable and all the connection points, and rectify any problems encountered.
	- Oven circuit breaker is not switched on.	Switch circuit breaker on or have it switched on. If it trips again, verify appliance is properly insulated; leakage currents must be less than 30mA.
	- System voltage is not present at the Ar Main board terminals.	Check voltage at terminals 1 and 2 of connector J18 (refer to the electronic diagram in this manual). If there is no voltage, disconnect connector J18: - If voltage is present again, replace the Main board, - If voltage is still absent, check the Tc power supply. Verify its correct operation is indicated by a green LED; if necessary, replace power supply.
	- Molex connector link cable between Main board and the screen is faulty.	Verify voltage is present. Check communication LEDs (see LED assignment section in this document). If the problem persists, replace the cable.
	- Screen is faulty.	If the problem persists, replace the screen.
	- Short-circuit at switching power supply output.	LEDs (switching power supply, red LEDs on the Main board) are flashing. Disconnect cable between the interface board and encoder board.
	- Encoder inoperative, LED ring does not light up.	Verify it is correctly connected and operating correctly. If problem persists, replace encoder board.
Screen inoperable, system won't start, random malfunctions, difficulty updating.		
	- Loss of communication.	Refer to the "screen inoperable or blocked" flowchart in this manual.
Display on, oven not working.		
	- An error code displayed (blocking message).	Refer to error code section of this manual.
	- The oven door is not closed properly.	Make sure oven door is correctly locked.
	- The switch does not detect when the oven is closed.	Check status of the door closing position switch in the technical panel, if the output remains at "0": On the Aar Main board, verify J5 connector is correctly connected to its socket, verify contact closes when the door is closed and that it is correctly fitted mechanically. If the problem persists, adjust the door and replace the switch if necessary.
The screen is lit, the oven works but the lighting does not.		
	- LED banners are not powered.	Refer to "Enclosure lighting fault" flow chart in this document.
The screen is lit, the oven, lighting and ventilation are working, but it does not heat up or does not reach the set temperature.		
Special case of electric ovens		
	- One or more heating elements do not work.	Refer to "electric heater fault" diagram in this document.
Special case of gas ovens		
Burner does not ignite.		
	- Spark box does not work.	Refer to "gas spark box fault" diagram in this document.
	- Gas fan not working.	Check fan power supply at terminal 2 of Kbg or Kbr and Xb. - if 230Va.c. present, change the fan. - if there is no 230Vac, verify Kbg or Kbr contactor is switched on, check the connections and tighten the screws, etc.
	- No gas or too low pressure.	Verify gas entering the appliance is of the correct type and pressure.
	- The gas valve does not work.	Check the resistance of the 848 Sigma gas solenoid valve coils Ev1 (terminals 4-3) and Ev2 (terminals 1-3); - If the resistance is greater than 0, check the gas pressure at the valve inlet and the burner heating demand; if the burner does not ignite, replace the valve, - If the resistance is equal to 0, replace the valve.
	- The ionisation electrode does not detect the flame.	Check electrode (see electrode adjustment section of this manual).
	- The flame control box does not work.	Turn off the gas supply and start cooking, if at the end of the ignition sequence: - "gas error" fault appears, the flame control box is operational, proceed with the above checks. - if the error does not appear, replace the flame control box.
Noisy burner.		
	- The gas settings are incorrect or the wrong gas is being connected.	Check in the technician parameters that the gas selected corresponds to what is indicated on the oven identification plate. Check gas supplied to the oven is the same as that indicated on the oven identification plate.

SYMPTOM	CAUSE	WHAT TO DO?
Noisy burner.		
	- Gas valve incorrectly set.	Check CO2 level by following the procedure indicated in the manual.
	- Air supply problem.	Check that the air inlet tube is correctly connected and that it is not obstructed.
	- The silicone venturi valve connection tube is disconnected or faulty.	Check that the tube is correctly connected. If the problem persists, replace it.
Explosion on starting gas burner.		
	- The ignition electrode is incorrectly adjusted.	Check the electrode settings: insulation of the wires in relation to ground (stray sparks), check that the electrode soapstone is not broken See "Checking the electrodes" section.
Polluting burner.		
	- The gas settings are incorrect or the wrong gas is being connected.	Check in technician parameters that gas selected corresponds to what is indicated on the oven identification plate. Check gas supplied to the oven is the same as what is indicated on the oven identification plate.
	- Gas valve incorrectly set.	Check CO2 level by following the procedure indicated in the manual.
Burner fan running at full speed.		
	- Communication fault between the Main board and the gas valve.	Check status of LEDs on gas board.
		- If they are off, verify the gas board is connected to the Main board (rear connector, condition of connections) and the gas board mounting screws are secure to the Main board. - If they are lit, check the various connections (screwing and fixing the connectors to their sockets) from gas board to the fan.
The burner emits a random whistling sound.		
	- When the oven is cold, a hissing sound may be heard.	This should disappear quickly as the burner heats up.
	- If the problem persists.	Check air intakes (unobstructed vents).
The spark box works continuously.		
	The Presence Flame (PF) does not return.	Fault in the connection between gas box and the gas board, verify wires and connections are secure. Fault in the connection between the gas board and Main board, check state of the LEDs on gas board, verify rear connection between the gas board and Main board, verify the gas board screws and connections are secure to the Main board, if the problem persists, replace the gas board.
The pump whistles.		
	- Air in the circuit.	Check the circuit for leaks (connections, hoses, etc.).
	- Defective bearings.	Verify the flow rate is as specified in this manual.

5.6 FLOWCHART

5.6.1 SCREEN INOPERATIVE OR BLOCKED

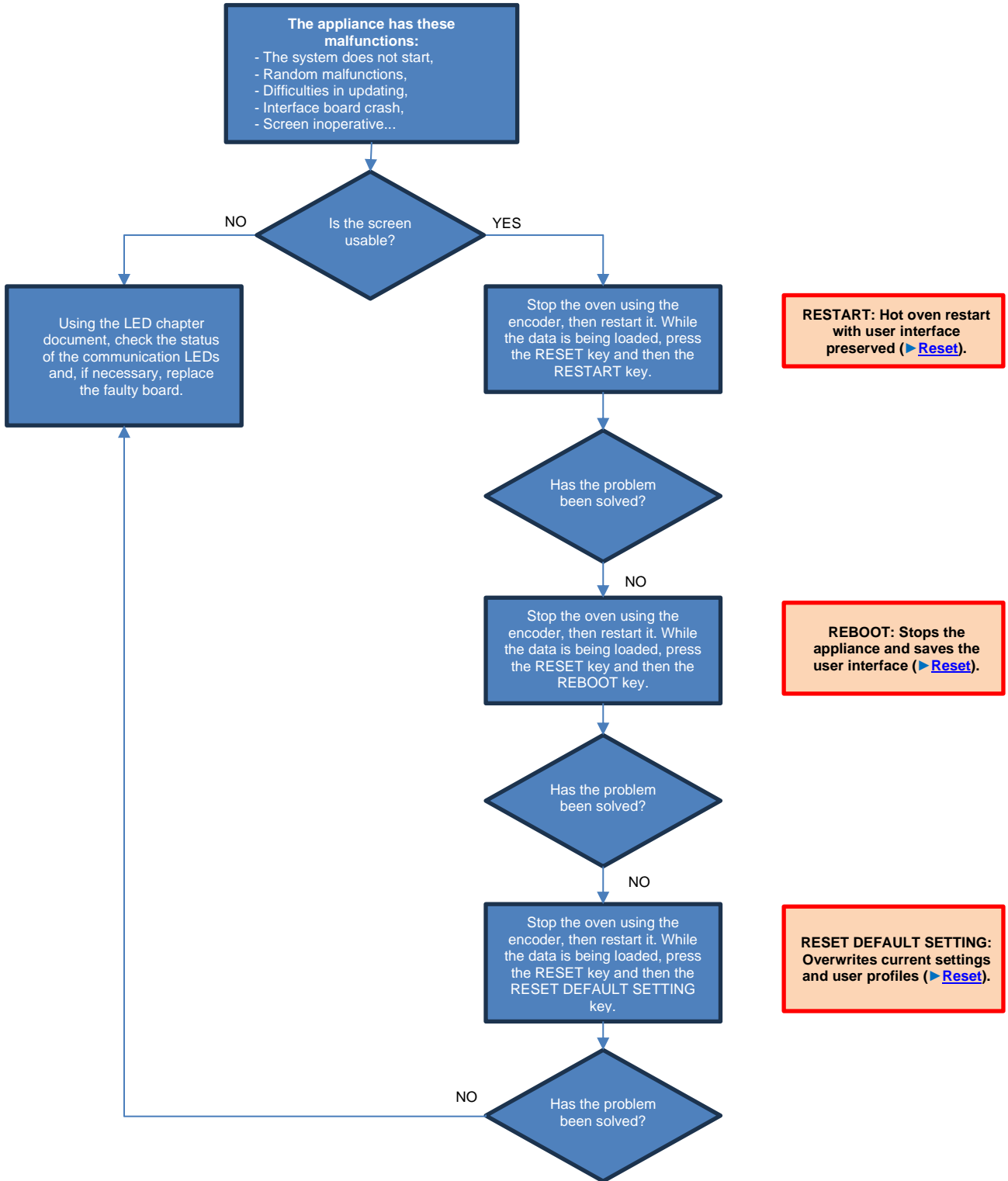

5.6.2 LIGHTING FAULT OF COOKING CAVITY

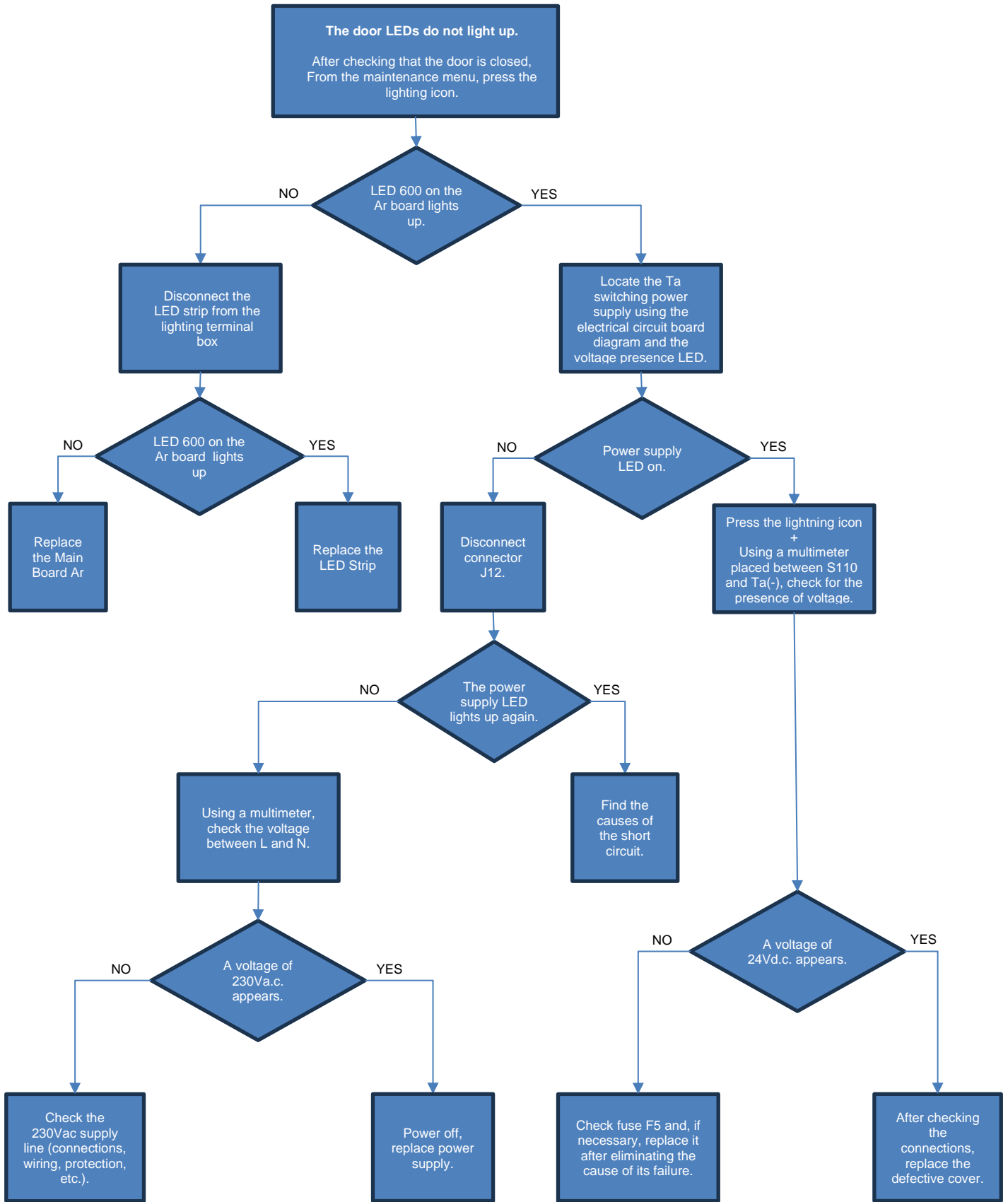

5.6.3 ELECTRIC HEATER FAULT

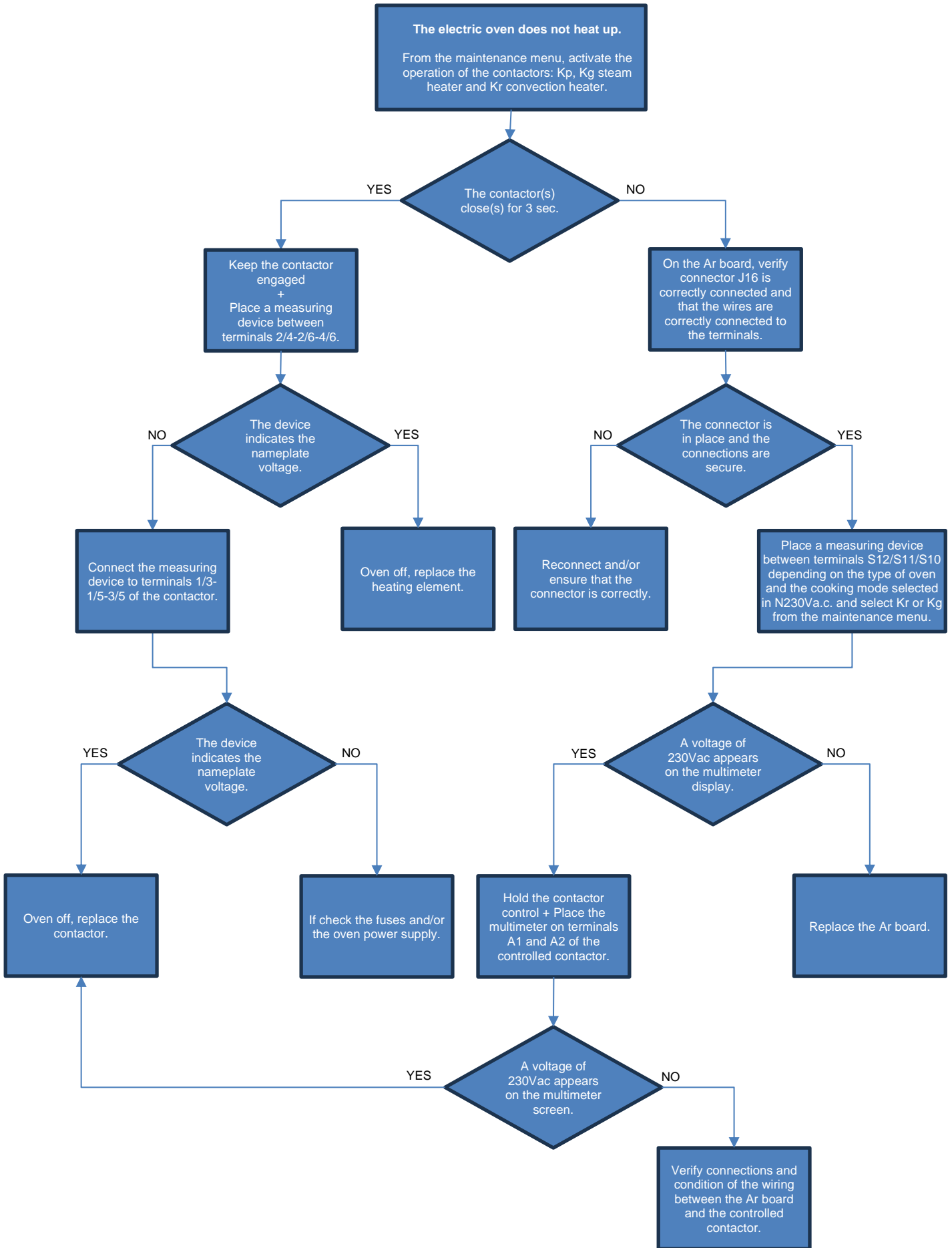

5.6.4 GAS SPARK BOX FAULT

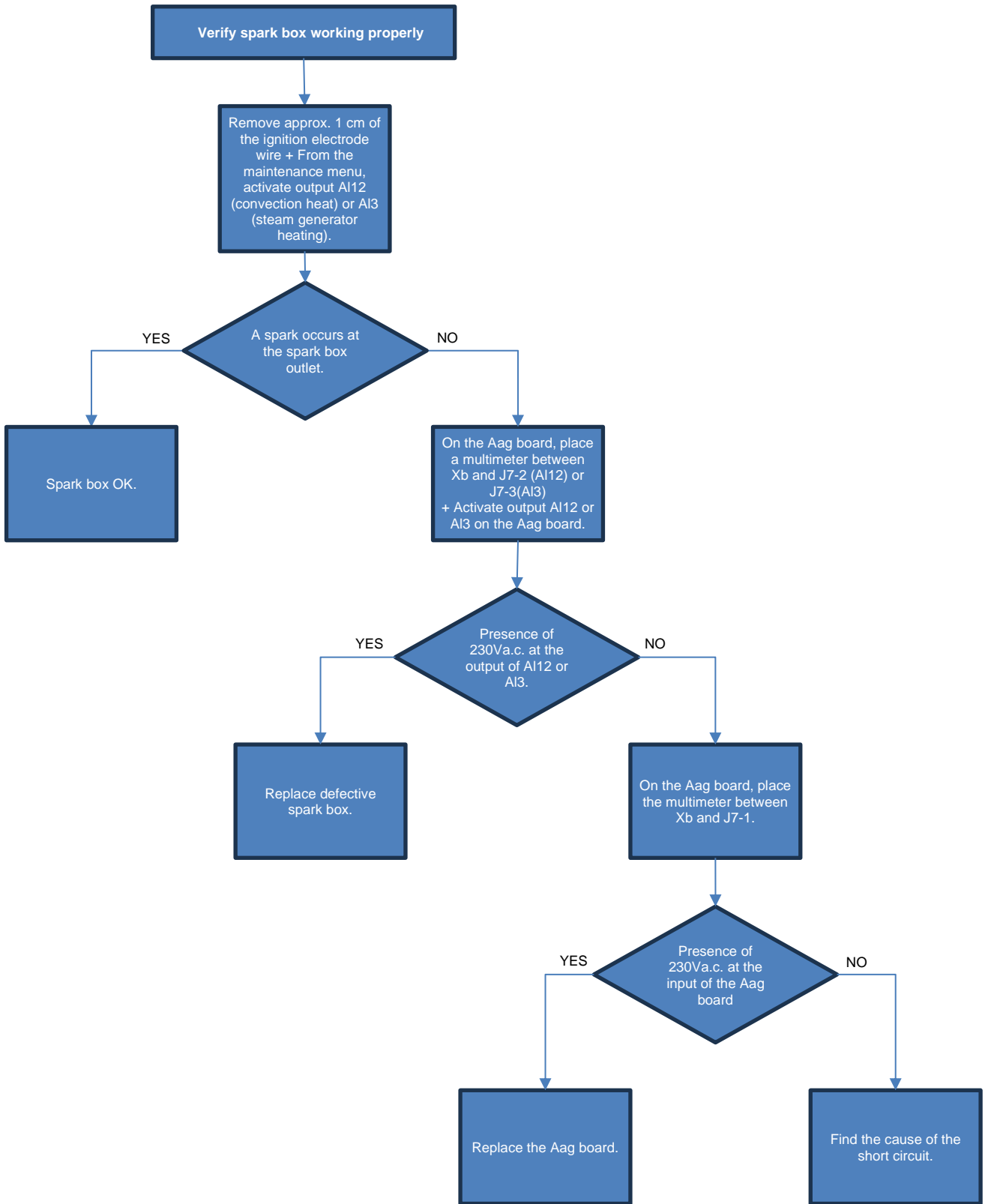

5.7 RESET

5.7.1 ACCESS TO THE RESET SCREEN

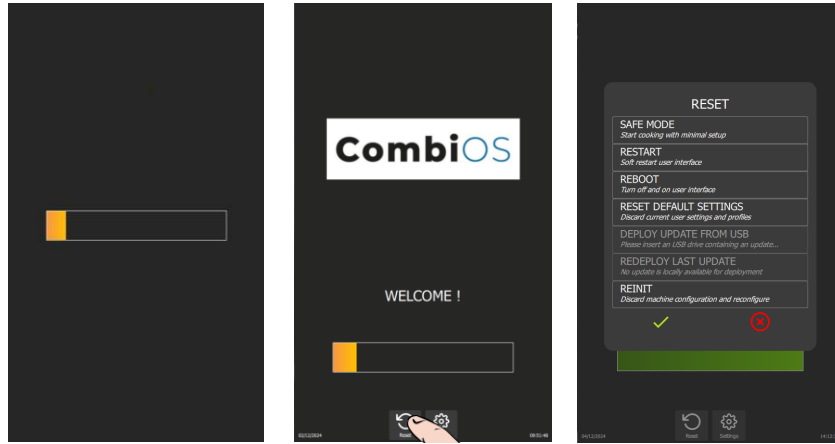

- » Switch on the display by holding down the encoder button until the power-on bar graph is displayed.
- » Wait for the "Home" menu to appear.
- » Press "Reset" button.
 - 🔗 The display shows a pop-up of possible actions.

5.7.2 PARAMETERS LIST

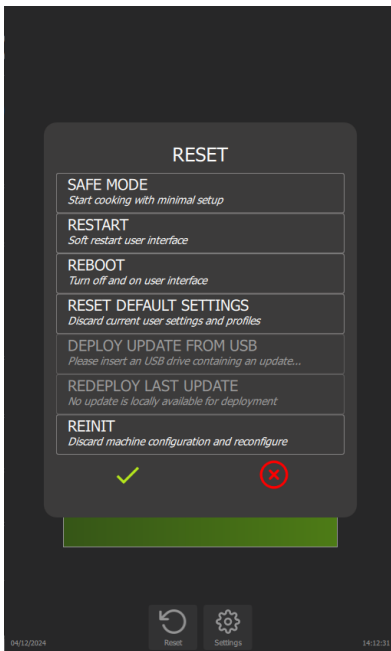

- ➔ Switch Chef'sCombi to Safe Mode
- ➔ Restart Interface
 - ➔ Restart interface and Main board
- ➔ Reset to default settings
- ➔ Reinstall an update from a USB key
- ➔ Reinstall last update
- ➔ Reset Chef'sCombi configuration (accessible with factory PIN code only)
- ➔ Validate or cancel selected "Reset" type

Safe mode

This action enables you to go into safe mode with minimal configuration. Only the ambient temperature: the default temperature is 356°F, and the cooking mode: convection heat cooking mode are indicated.

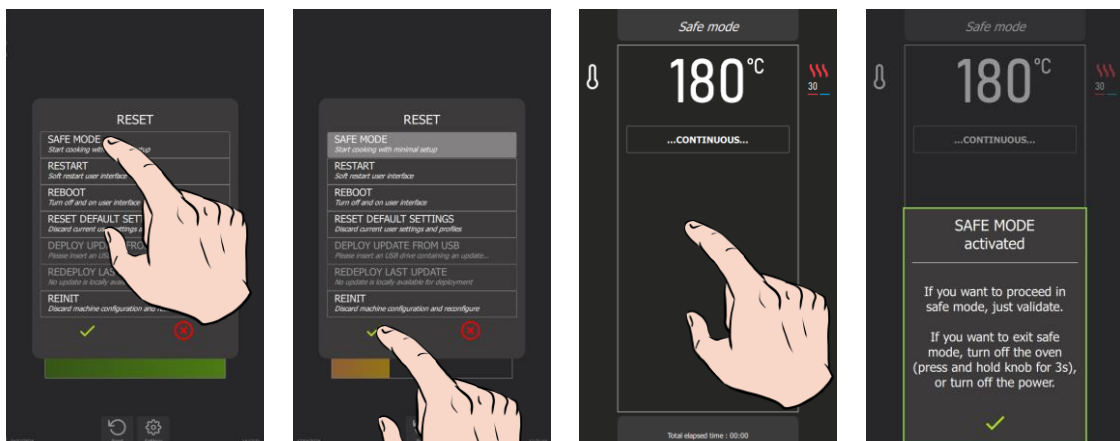

On confirmation, the continuous icon appears on the display, indicating cooking similar to the continuous cooking mode. When the screen is pressed, an information message appears, indicating the following:

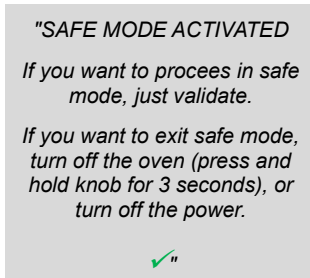

In the event of a problem with the screen, this mode can be obtained by successively opening the door 3 times within 5 seconds at power-up.

Restart: Restart the interface

This option performs a basic restart of the Chef'sCombi interface. **No customer-configured parameters are affected.**

Reboot: Restart with reset

This function restarts the unit and exits the current cycle. **No customer-configured parameters are affected.**

Reset default settings

This function resets current settings and user profiles. Access to this action is protected by a PIN code (level 5 or 7), guaranteeing the security of the process (► [Settings](#) – PIN Codes).

In particular, it deletes parameters, profiles, customer protocols, manufacturer protocols and customer photos.

After a reset, it is necessary to redo the CO control and "Steam generator calibration".



WARNING! Please inform the customer!

All parameters configured and copied by the customer, such as settings, profiles, protocols (recipes), photos, etc... will be deleted.

Deploy update from USB : Reinstall an update from a USB stick

This feature is active when a USB key is connected to the appliance. It allows you to reinstall (force) an update from a USB key.



When a manufacturer update is in progress, there is no need to activate this menu. If the update version on the USB key is higher than the one already present in the chef'sCombi memory, the update starts automatically (► [Settings](#) - Updating the software).

Redeploy last update : Reinstall the last update

This menu allows you to reinstall the latest update installed on the appliance. It is essential to select this option when corrupted parameters have been installed or detected by the appliance. A clean backup is kept on the SD card.

6. ELECTRIC DIAGRAMS

6.1 DIAGRAMS

6.1.1 GAS OVENS

Wiring diagram

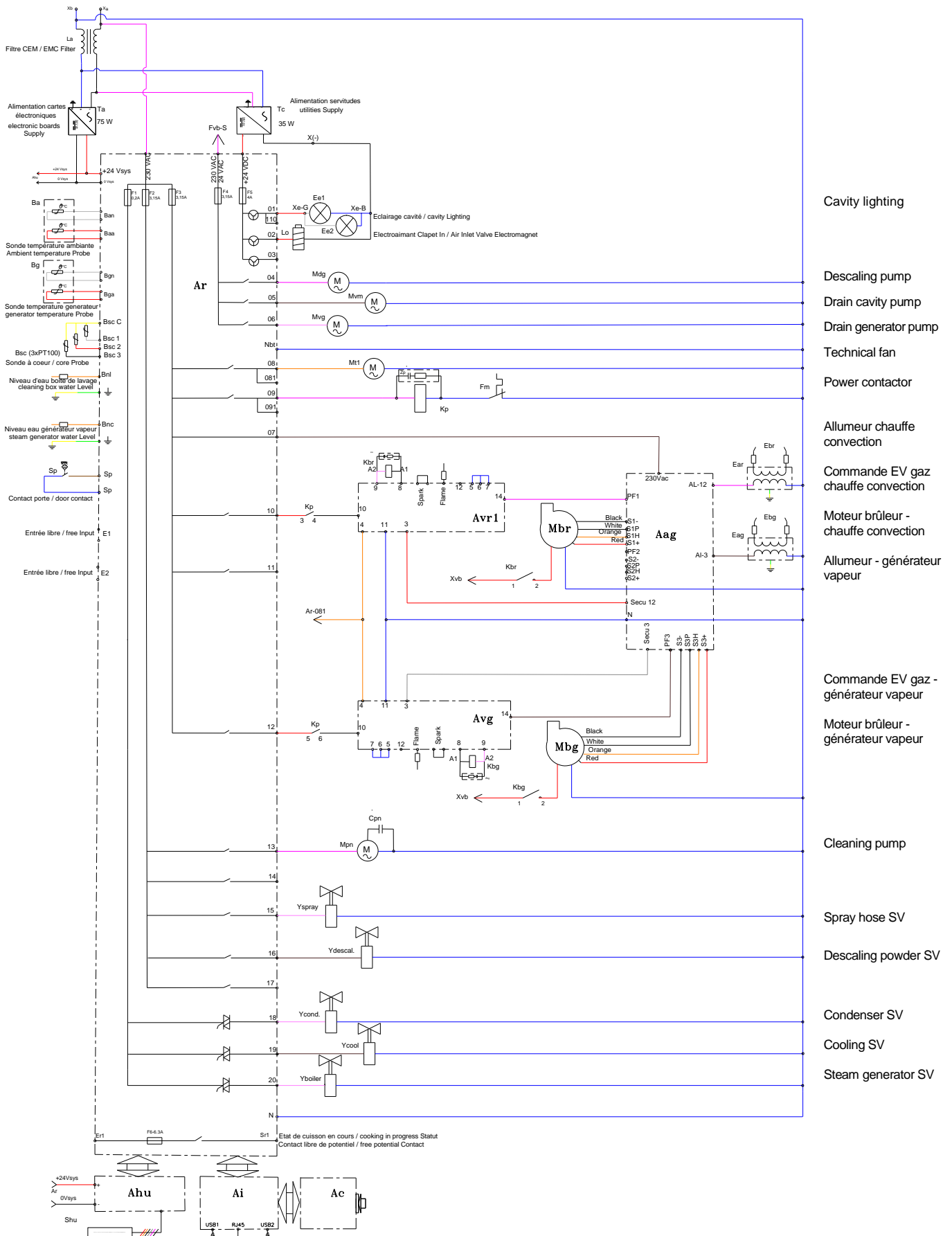

Power diagram 6 & 10 GN 1/1

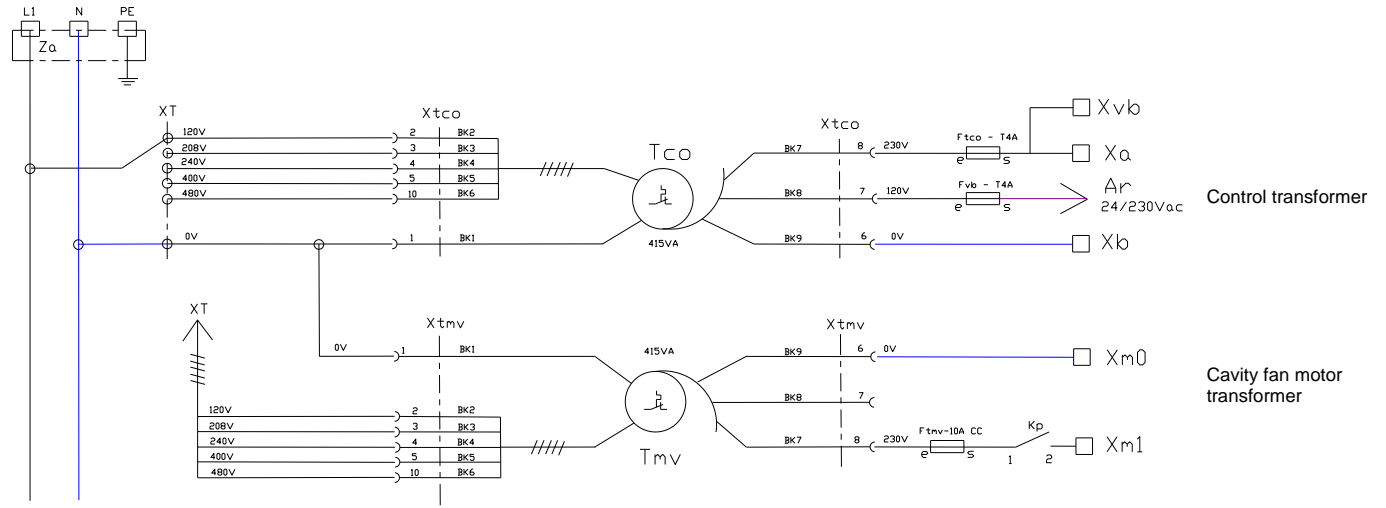

Power diagram 6 & 10 GN 2/1

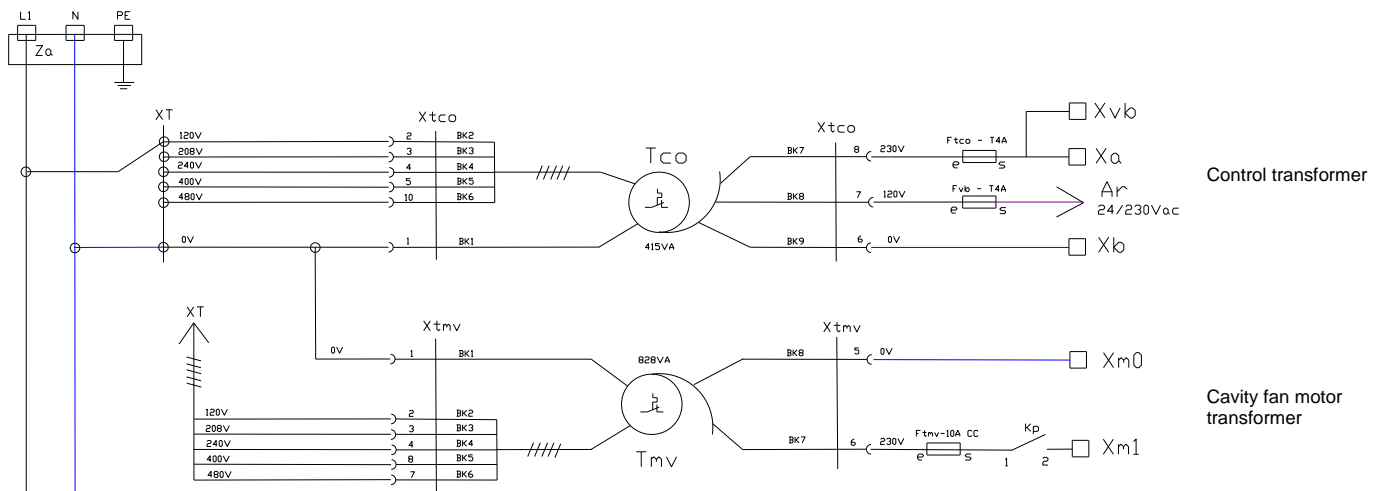

6.1.2 ELECTRIC OVENS

Wiring diagram

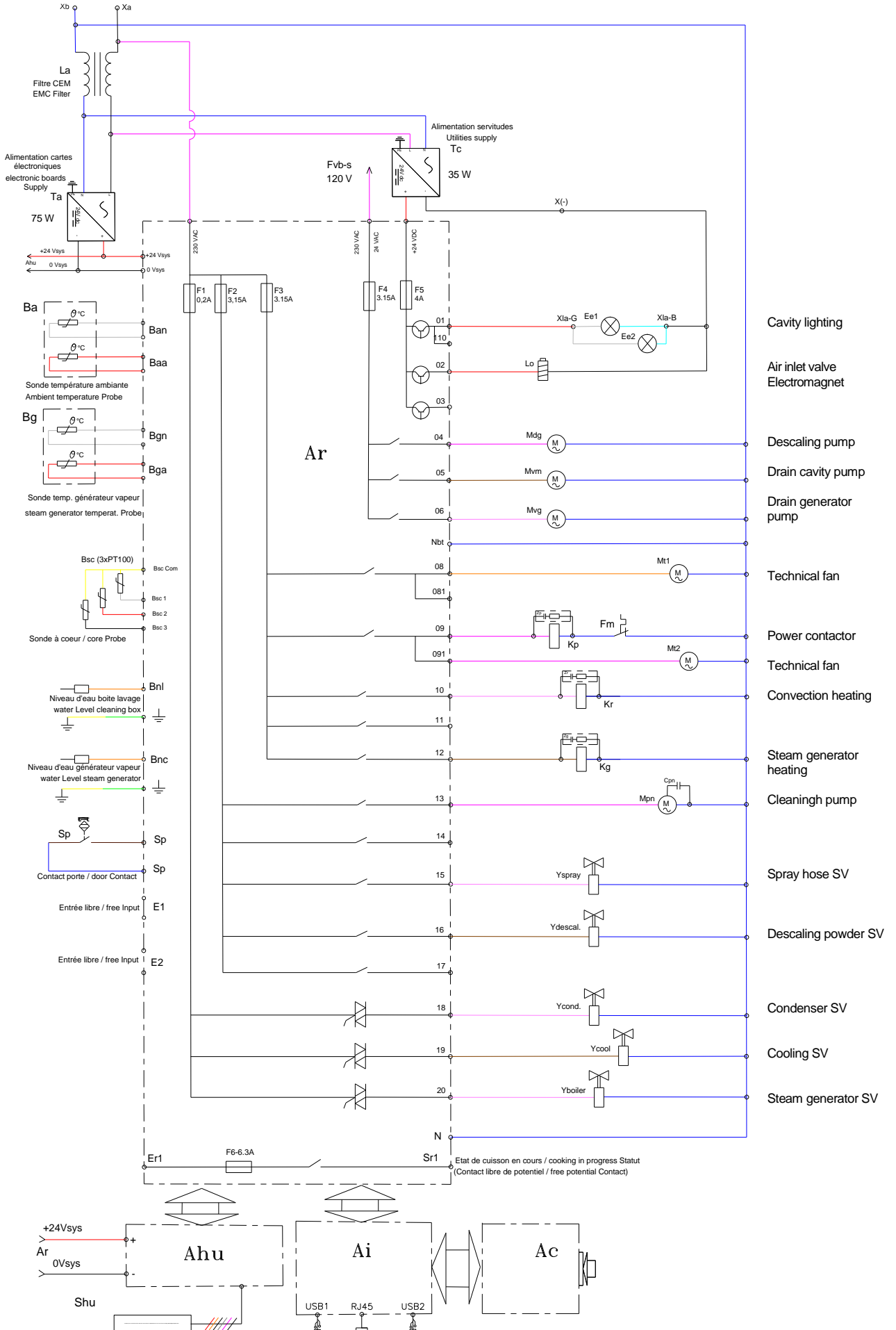

Power diagram 6GN1/1 – 208V – 240V

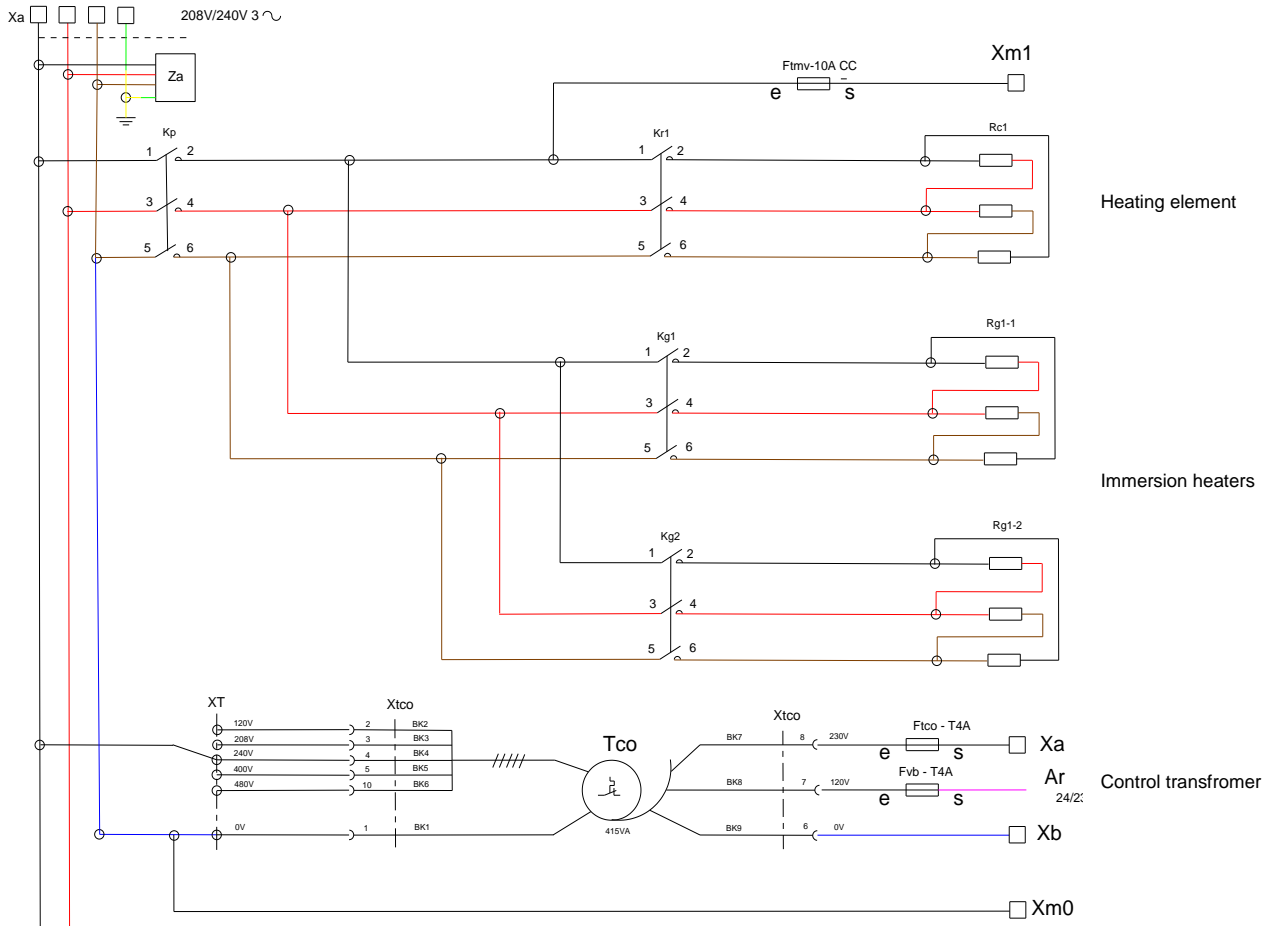

Power diagram 6GN1/1 – 480V

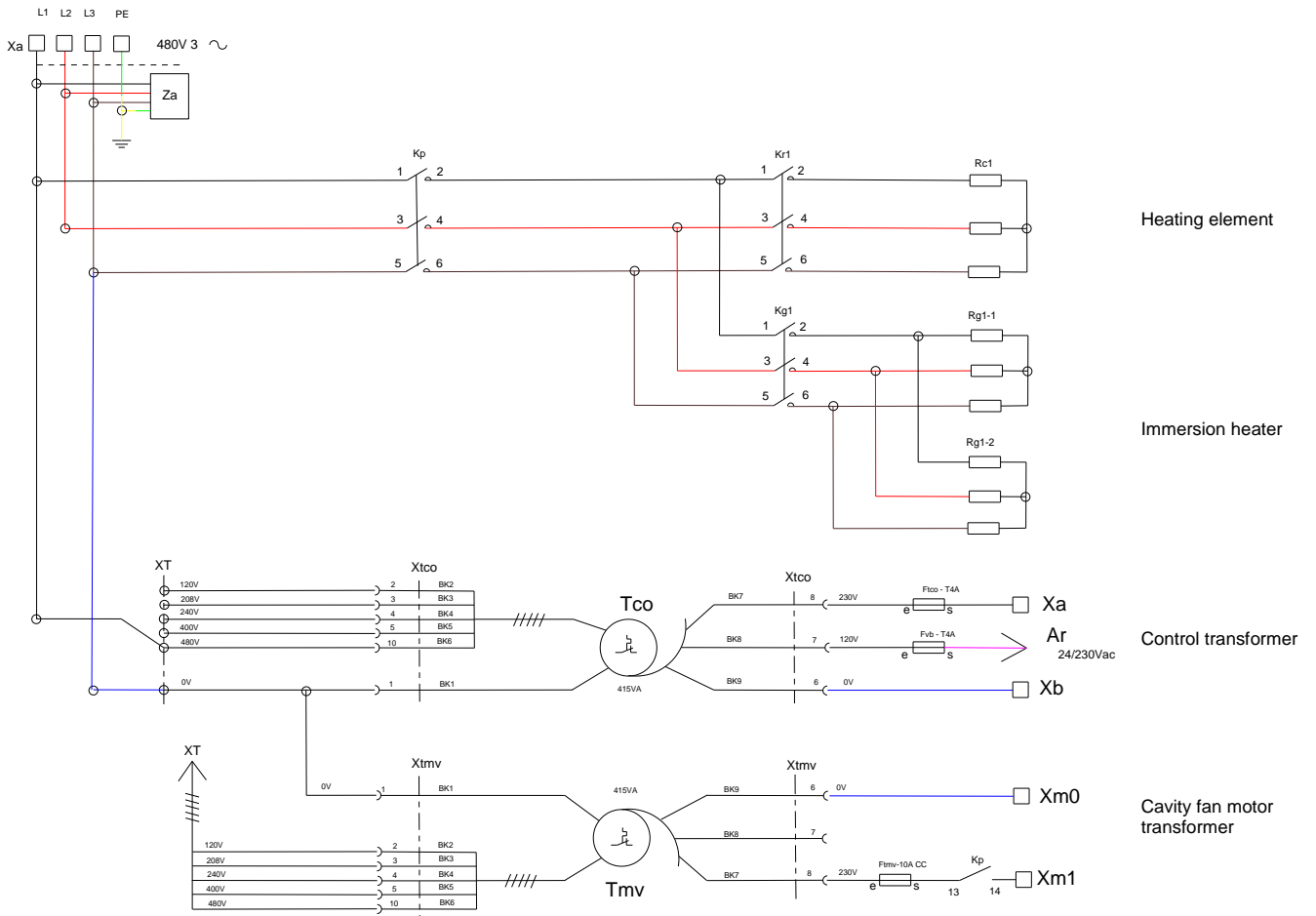

Power diagram 6GN2/1 – 480V

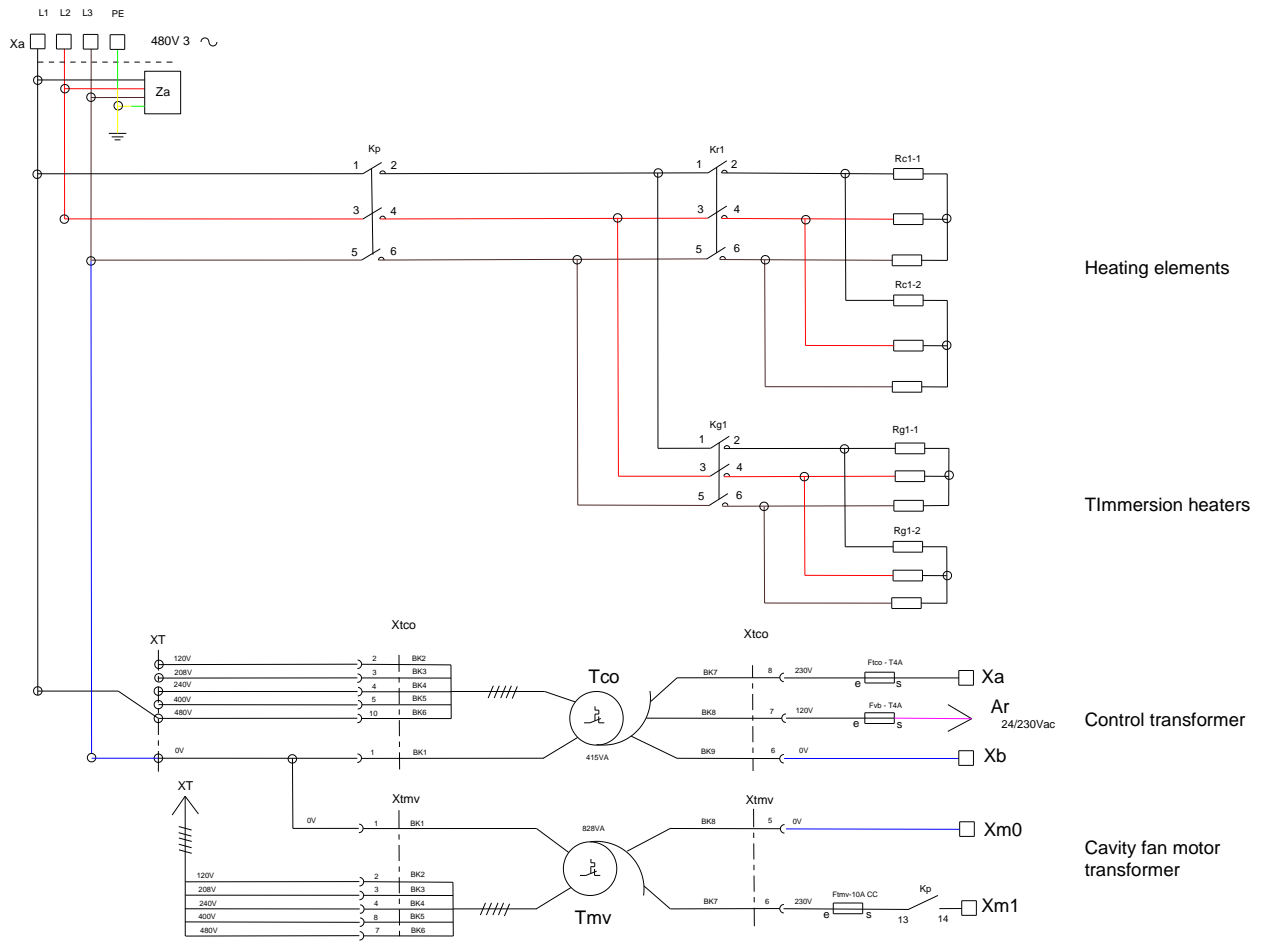

Power diagram 6GN2/1 and 10GN1/1 – 208V-240V

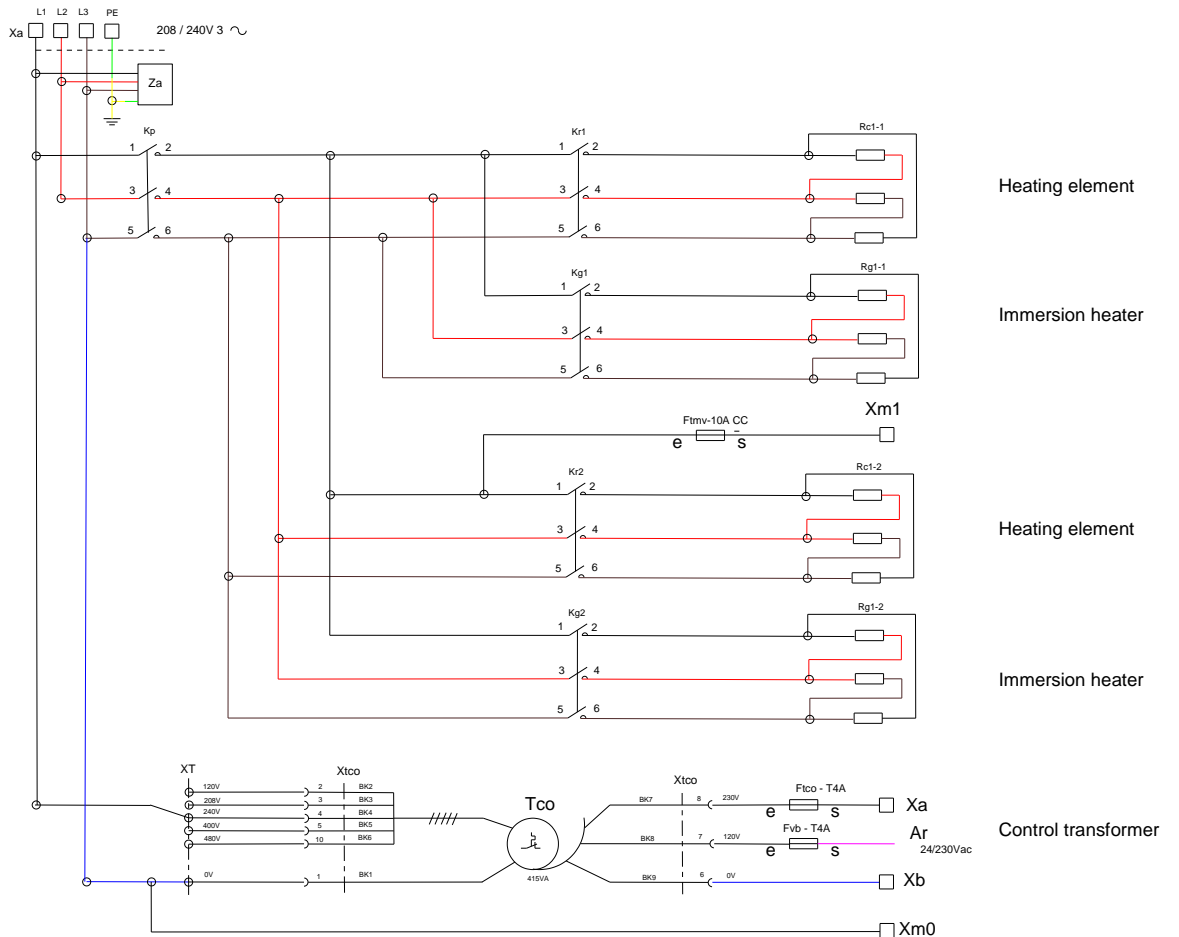

Power diagram 10GN1/1 – 480V

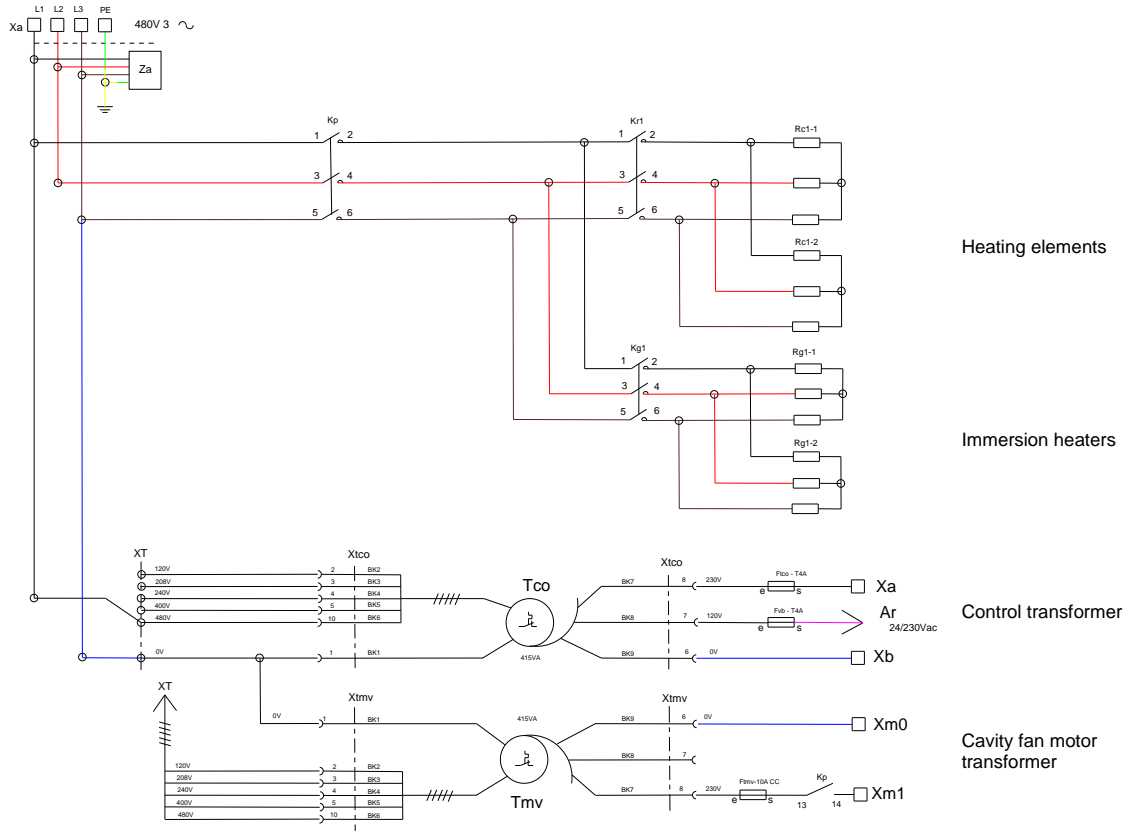

Power diagram 10GN2/1 – 480V

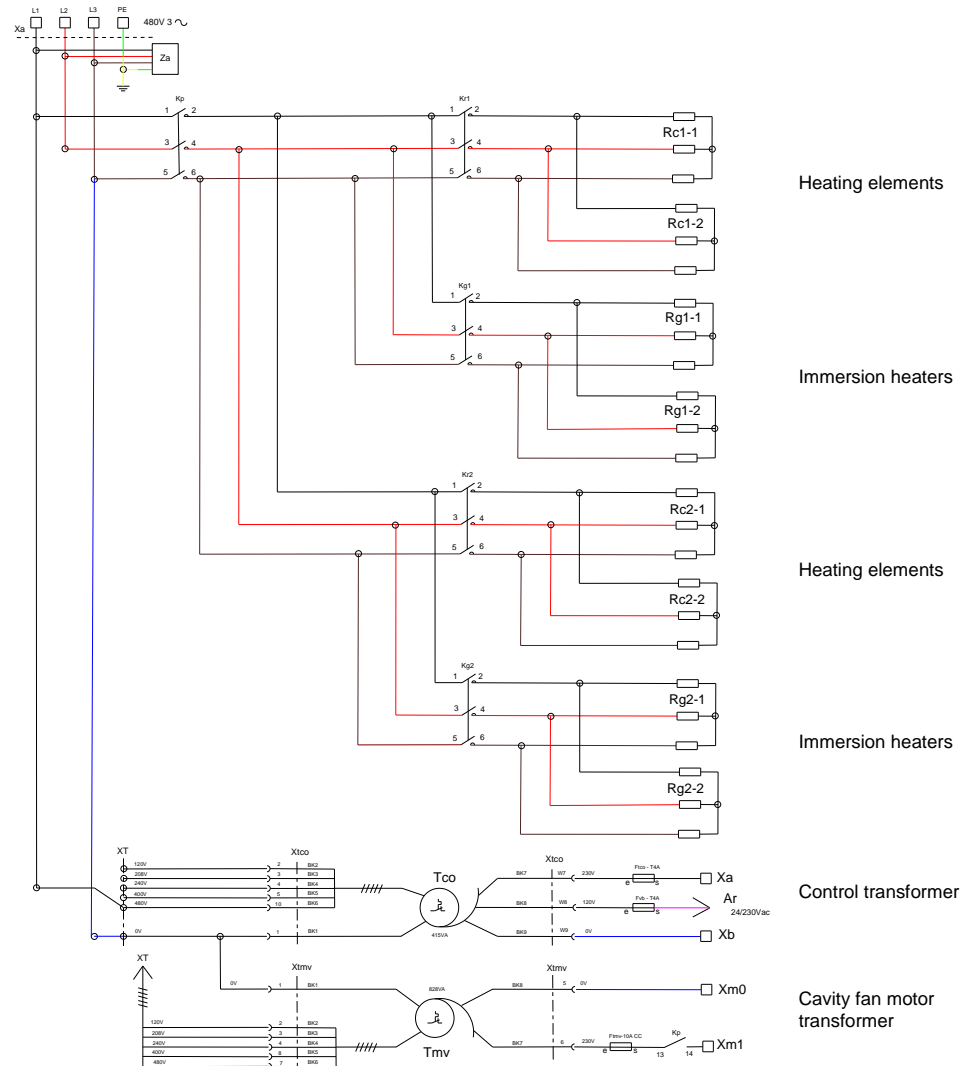

Power diagram 10GN2/1 – 208V-240V

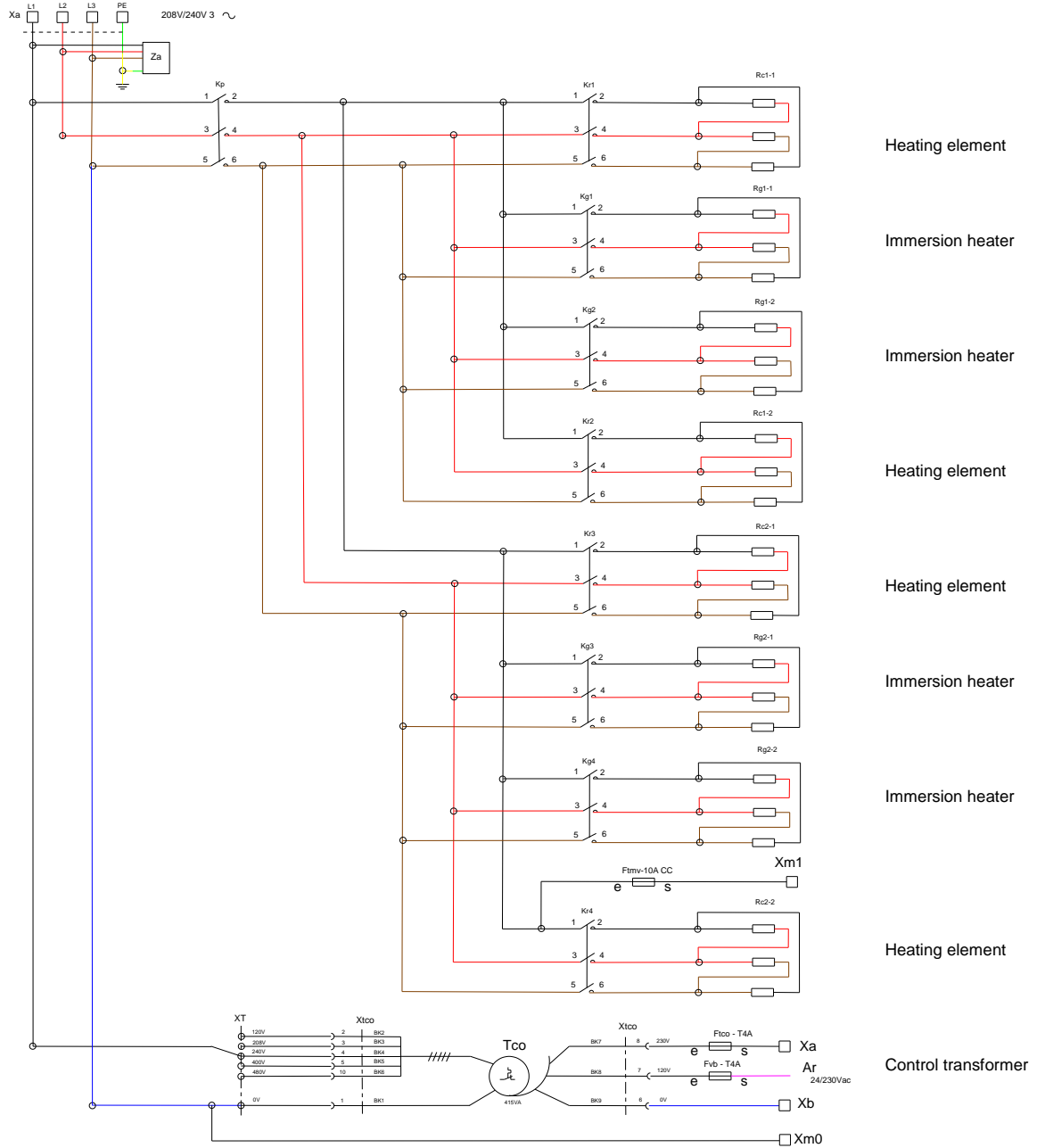

6.2 6 AND 10 LEVEL CAVITY VENTILATION

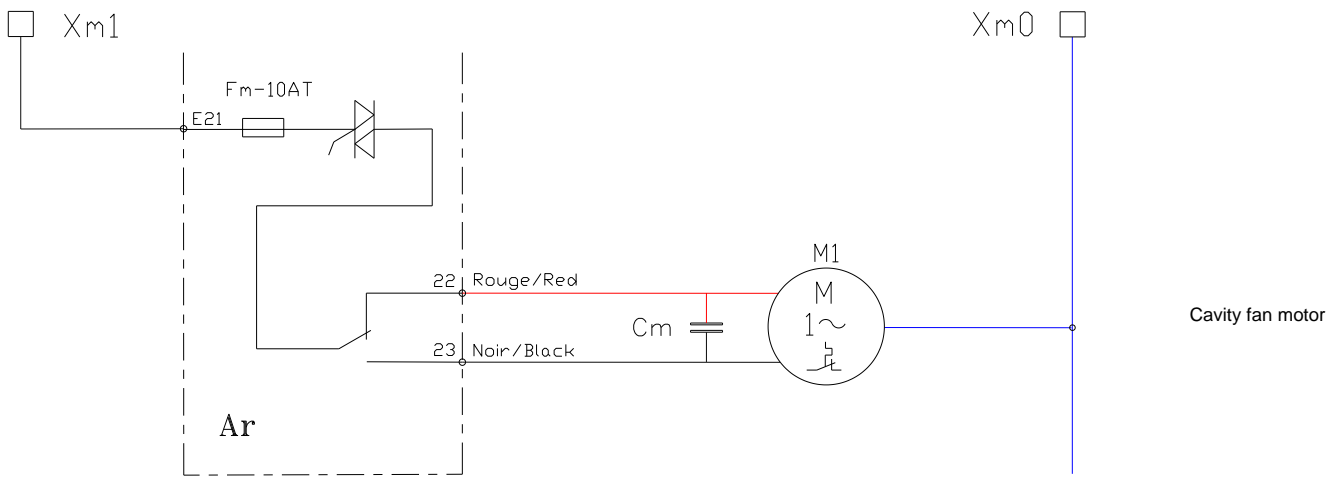

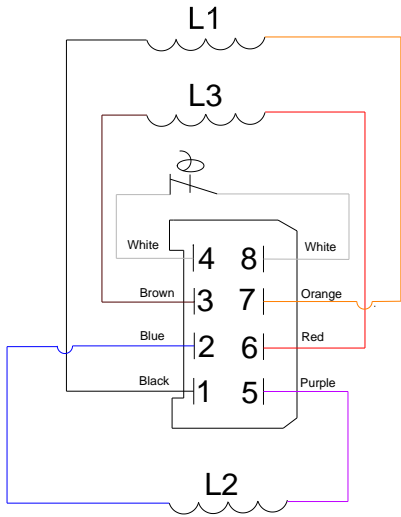

	Half size motor	Full size motor
L1	56 Ω	20.4 Ω
L2	56 Ω	20.4 Ω
L3	56 Ω	20.4 Ω

Values tolerances +/-15%

6.3 GREASE COLLECTION OPTION

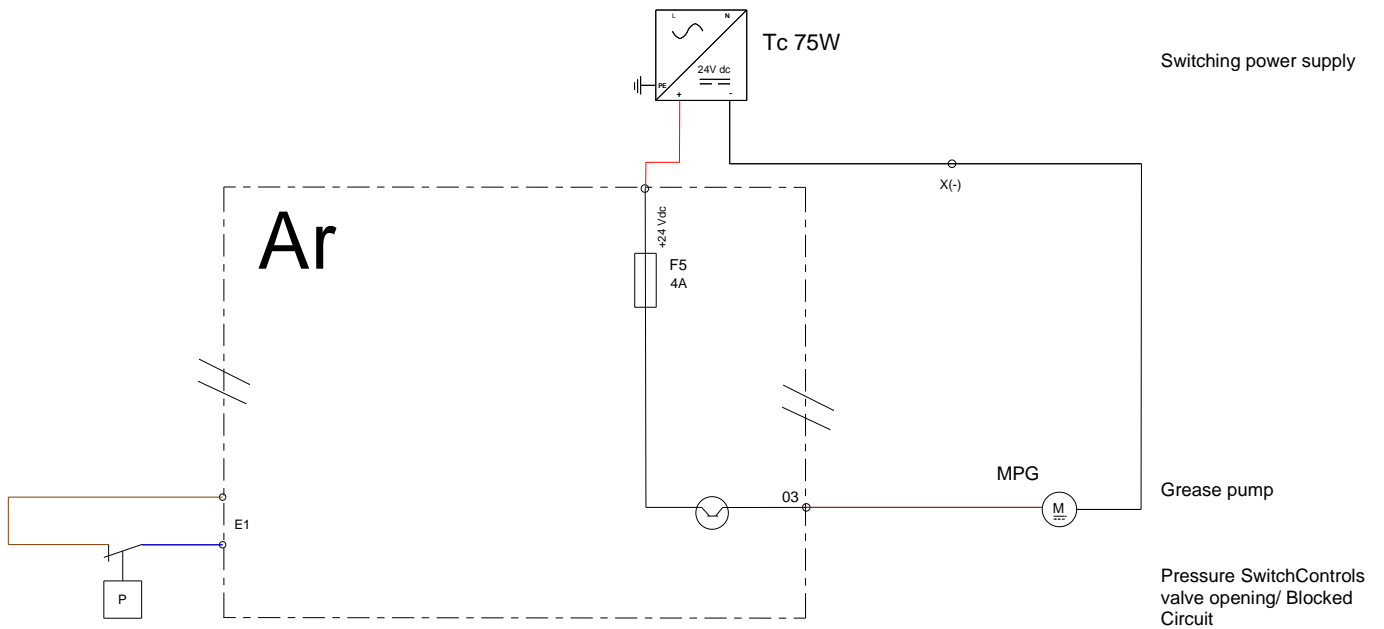

6.4 PARTS LIST

Common components

Ref.	Designation	Characteristics	Quantity	Code
Ac	Encoder board		1	309716
Ahu	Additional humidity board		1	309718
Ai	Interface board		1	309714
Ar+Ah	Main + humidity boards	Electric oven	1	309720
	Connection cable for Main – interface boards		1	309723
Ar+Ah+Aag	Main + humidity + gas boards	Gas oven	1	309721
Ba	Ambient probe	PT100	1	159030
Bg	Steam generator temperature probe	PT100	1	159028
Bnc	Steam generator level probe		1	301514
Bnl	Cleaning box level probe		1	301519
Bsc	Core probe	3-point probe - 6- level GN 1/1 ovens	1	301517
		3-point probe - 10-level GN 2/1 ovens	1	301518
		Probe 3 points - 6 levels GN2/1 & 10 levels GN1/1	1	301524
Cpn	Cleaning pump condensator	6.3µF	1	304311
Cm	Cavity motor condensator	12,5µF - GN1/1 oven	1	304296
		25µF - GN2/1 oven	1	304326
Ee1 - Ee2	LED strips	24Vd.c. 5W	1	309719
F1	Fast fuse	5x20 - 0,2 A	1	300787
F2 - F3 - F4	Time-delay fuses	5x20 - 3,15A	3	309407
F5	Standard automotive fuse	ATC - 4A	1	300807
Fm	Motor fuse	5x20 - 10A	1	300788
Ftco	Fuse holder and fuse	4A T	1	300777 + 300801
Ftmv	Fuse holder and fuse	10A CC	1	300792 + 300793
Fvb	Fuse holder and fuse	4A T	1	300777 + 300801
La	EMC filter		1	309639
Lo	Electromagnet of In flapper	24Vd.c. 8,3W	1	468108
M1	Cavity fan motor	6 and 10 levels GN1/1	1	147147
		6 and 10 levels GN2/1	1	159032
Mdg	Descaling pump motor	56W - Steam generator	1	304321
Mpg	Grease pump motor	24Vdc 31W	1	304314
Mpn	Cleaning pump motor	253W	1	314396
Mt1 – Mt2	Technical ventilation motor		1	304334
Mvg	Steam generator drain motor	56W	1	304323
Mvm	Cavity fan motor	56W	1	304322
P	Pressure switch			159064
Shu	Humidity sensor		1	301515
Sp	Closed door reed switch	Standard door	1	300806
		Reversed door option (left-hand fitting)	1	300805
Ta	Switching power supply	230Va.c. / 24Vd.c.	1	300802
Tc	Switching power supply	230Va.c. / 24Vd.c.	1	308353
		230Va.c. / 24Vd.c. if grease collection option	1	300802
Tco	Control transformer	415VA	1	408407
Tcm	Cavity fan motor transformer	6 and 10 levels GN1/1	1	408407
		6 and 10 levels GN2/1	1	408406
Yspray - Ycond	Two-way solenoid valve	Spray / Condenser	1	468105
Ycool - Yboiler - Ydescal.	Three-way solenoid valve	Descaling / Steam generator / Injection	1	468107

Contactors Electric ovens

208V/240V - 230V

Ref.	Designation	6 GN1/1	6 GN2/1	10 GN1/1	10 GN2/1
Kg	Steam generator contactor	300699 * 2	300699 * 2	300699 * 2	300699 * 4
Zg	Interference-suppression Blocks	300769 * 2	300769 * 2	300769 * 2	300769 * 4
Kp	Power contactor	300699	300702	300702	300798
Zp	Interference-suppression Blocks	300769	407002	407002	300799
Kr	Regulation contactor (convection heater)	300699	300699 * 2	300699 * 2	300699 * 4
Zr	Interference-suppression Blocks	300769	300769 * 2	300769 * 2	300769 * 4

480V

Ref.	Designation	6 GN1/1	6 GN2/1	10 GN1/1	10 GN2/1
Kg	Steam generator contactor	300697	300698	300698	300698 * 2
Zg	Interference-suppression Blocks	300769	300769	300769	300769 * 2
Kp	Power contactor	300697	300699	300698	300702
Zp	Interference-suppression Blocks	300769	300769	300769	407002
Kr	Regulation contactor (convection heater)	300697	300699	300698	300699 * 2
Zr	Interference-suppression Blocks	300769	300769	300769	300769 * 2

Contactors Gas ovens

Ref.	Designation	6 GN1/1	6 GN2/1	10 GN1/1	10 GN2/1
Kbg	Steam generator burner contactor	300697	300697	300697	300697
Kbr	Burner regulation switch	300697	300697	300697	300697
Kp	Power contactor	300697	300697	300697	300697
Zp - Zvb - Zbg	Interference suppressor	300769	300769	300769	300769

Heating elements Electric oven

Ref.	Designation		6 GN1/1	6 GN2/1	10 GN1/1	10 GN2/1	
Rc	Convection heating elements	208V	Codes	159010	159012	159013	159012+159014
			Vulcan codes	00-978295	00-978296	00-978308	00-978296+00-978298
		240V	Codes	159005	159007	159008	159007+159009
			Vulcan codes	00-978291	00-978292	00-978293	00-978292+00-978294
		480V	Codes	159015	159017	159018	159017+159019
			Vulcan codes	00-978299	00-978300	00-978301	00-978300+00-978302
Rg	Steam generator immersion heaters	208V	Codes	159024	159025	159025	159025 * 2
			Vulcan codes	00-978305	00-978306	00-978306	00-978306 * 2
		240V	Codes	159022	159023	159023	159023 * 2
			Vulcan codes	00-978303	00-978304	00-978304	00-978304 * 2
		480V	Codes	159026	159027	159027	159027 * 2
			Vulcan codes	00-978305	00-978308	00-978308	00-978308 * 2

Specific components - Gas ovens

Ref.	Designation	Characteristics	Quantity	Code
Aag	Additional gas board		1	309721
Avg	Steam generator gas solenoid valves		1	310356
Avr1	Gas solenoid valves regulation 1		1	310356
Eag	Steam generator gas spark box	prim:230Va.c. 0,3A /sec 1x15kV	1	408402
Ear	Gas spark box for convection heaters 1/2	prim:230Va.c. 0,3A /sec 1x15kV	1 or 2	408402
Ebg - Ebr	Curved ignition electrode		2	148885
	Straight ionisation electrode		2	148886
Flamme	Flame control electrode		2	148889
Mbg	Steam generator burner motor	207VA	1	159046
Mbr	Burner motor regulation	207VA	1	159046

7. HYDRAULIC DIAGRAM

7.1 6 AND 10 LEVEL OVENS

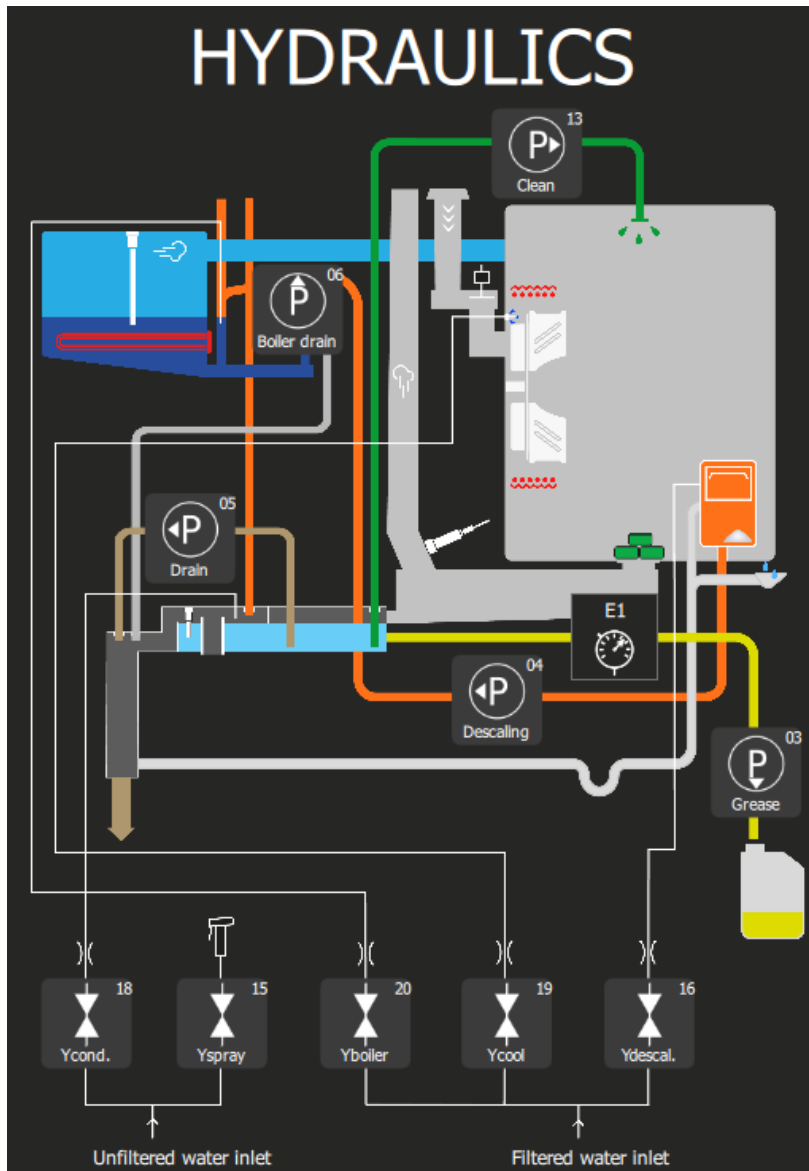

UNFILTERED WATER (hard water inlet)	
Pressure (Min / Max)	14.5 psi / 87psi (1.5 bar / 6 bar)
Max cold water temperature	73°F
Nature	Filtered at 114 mesh
Water quality	Chloride Cl ⁻ : ≤ 8.76 gr/gal (150 ppm) Chlorine Cl ₂ : ≤ 0.01 gr/gal (0.2 ppm) 6.5 ≤ PH ≤ 9
Conductivity	≥ 25 TDS
Connection	Male G 3/4" + GHT 3/4" adapter
Max. instantaneous consumption	3.35 gpm

FILTERED WATER (Soft water inlet)	
Pressure (Min / Max)	14.5 psi / 87psi (1.5 bar / 6 bar)
Max cold water temperature	73°F
Nature	Filtered at 114 mesh
Hardness	3.5 to 11.6 grains/gal (60 to 200 ppm)
Water quality	Chloride Cl ⁻ : ≤ 8.76 gr/gal (150 ppm) Chlorine Cl ₂ : ≤ 0.01 gr/gal (0.2 ppm) 6.5 ≤ PH ≤ 9
Conductivity	≥ 25 TDS
Connection	Male G 3/4" + GHT 3/4" adapter
Max. instantaneous consumption	2.03 gpm

TWO-WAY SOLENOID VALVE - COLD WATER		
Ycond	Condenser solenoid valve	42,8 gal/h
Yspray	Solenoid valve for spray hose	158,5 gal/h

THREE-WAY SOLENOID VALVE - COLD WATER		
Yboiler	Solenoid valve for steam generator filling	87.1 gal/h
Ycool	Cooling solenoid valve	14.4 gal/h
Ydescal.	Descaling solenoid valve	14.4 gal/h

PUMPS		
P - 04	Clean	2061 gal/h
P - 03	Descaling	317 gal/h
P - 13	Drain	317 gal/h
P - 05	Drain steam generator	317 gal/h
P - 06	Grease	52,31 gal/h

PRESSURE SWITCH (GREASE COLLECTION OPTION)		
E1	Pressure switch	0.3 bars



7.1.1 FLOW LIMITER

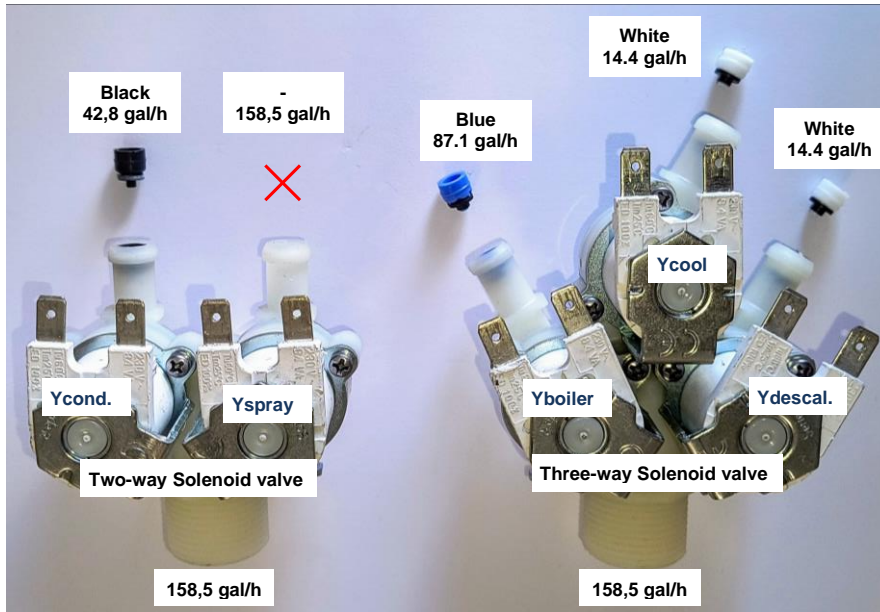

7.1.2 IDENTIFICATION OF TERMINALS

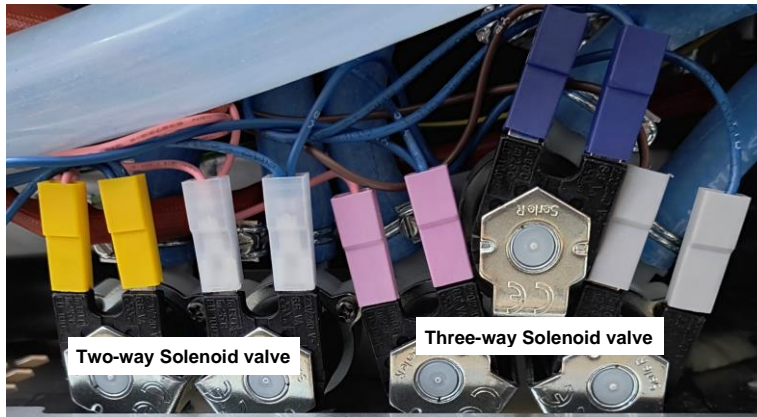

	<u>Two-way Solenoid valve</u>	<u>Three-way Solenoid valve</u>
	Condenser → Yellow Spray hose → Clear - Transparent	Cooling → Blue Steam generator → Pink - purple Descaling → Grey



8. GAS DIAGRAM

8.1 6 AND 10 LEVEL OVENS

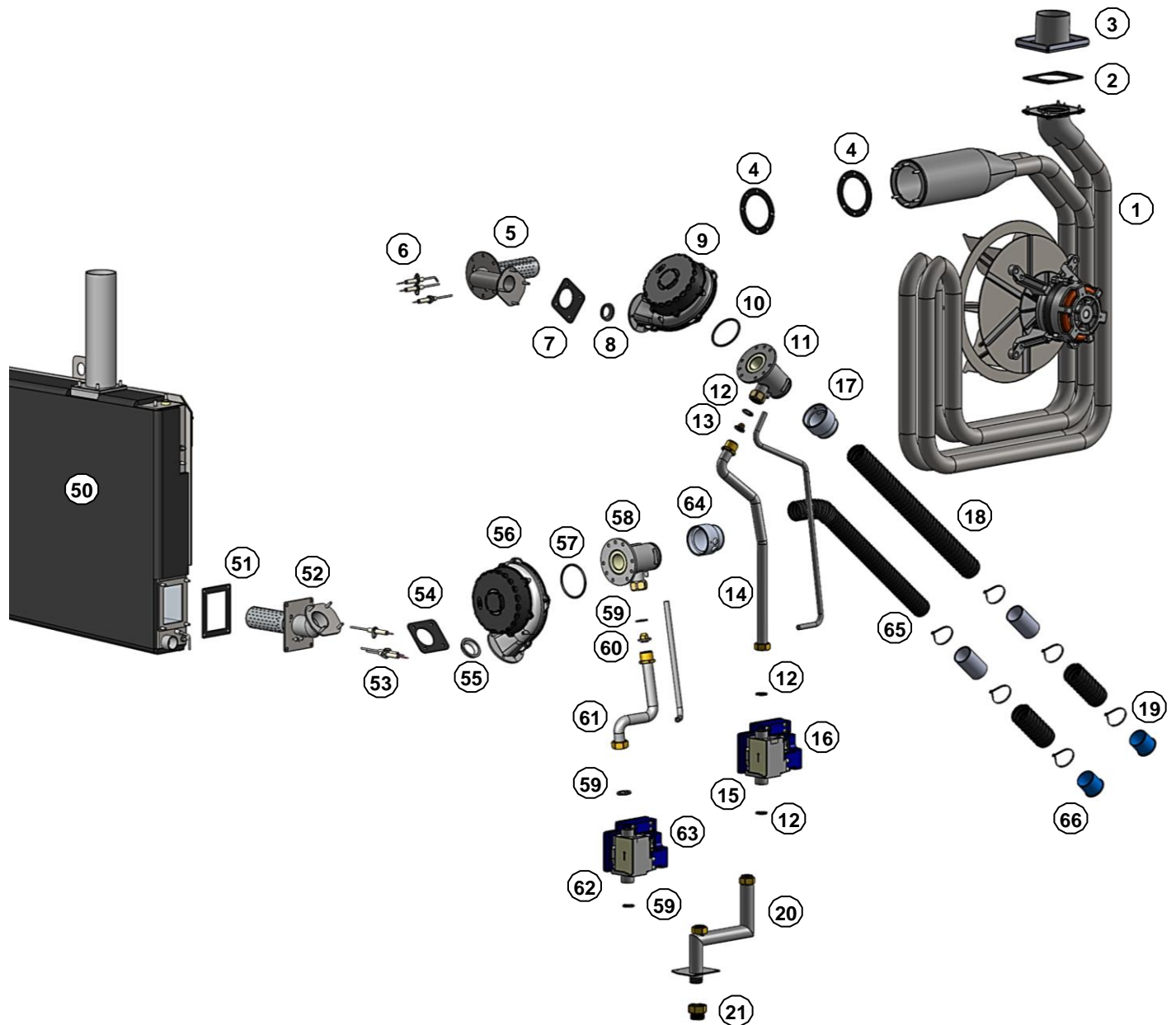
**Gas circuit - Convection heating**

- 1 Heat exchanger
- 2 Gas exchanger outlet gasket
- 3 Flue gas pipe
- 4 Gas exchanger inlet gasket
- 5 Gas burner
- 6 Ignition electrodes
- 7 Gas burner gasket
- 8 Gas burner reducer
- 9 Gas burner blower
- 10 Gas venturi seal
- 11 Venturi
- 12 Gasket 20/27
- 13 Injector (present depending on model)
- 14 Gas pipework
- 15 Gas valve
- 16 Safety box
- 17 Venturi adapter
- 18 Air inlet hose
- 19 Flexible air plug
- 20 Gas ramp
- 21 3/4" NPT gas inlet adaptor

Gas circuit - Steam heating

- 50 Gas steam generator
- 51 Steam generator inlet gasket
- 52 Gas burner
- 53 Ignition electrodes
- 54 Gas fan gasket
- 55 Gas burner reducer
- 56 Gas burner blower
- 57 Gas venturi seal
- 58 Venturi
- 59 Gasket 20/27
- 60 Injector (present depending on model)
- 61 Gas pipework
- 62 Gas valve
- 63 Safety box
- 64 Venturi adapter
- 65 Air inlet hose
- 66 Flexible air plug

9. ACCESS TO COMPONENTS

9.1 LOCATION OF TECHNICAL COMPONENTS



9.2 ACCESS TO COMPONENTS



CAUTION: The appliance must be disconnected from its power supply during cleaning or maintenance, and when replacing parts.

The various assembly procedures and component access below are designed to avoid any repetition which could lead to errors when improving the procedures.

Actions already explained in a paragraph are not re-explained but are referred to in the paragraph originally concerned, using the symbol « ▶ » followed by the title of the paragraph where the procedure can be found.

9.2.1 LEFT-HAND SIDE PANEL

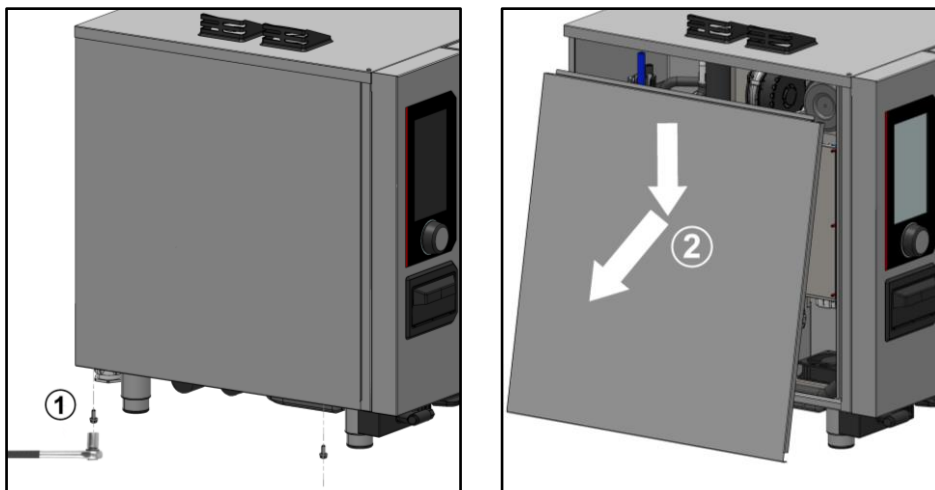

- » Prepare your intervention:
 - ✓ Tools: Wrenches.
- » Unscrew and remove the 2 x M5 screws securing the underside of the panel ①.
- » Remove the panel: Unhook the bottom of the panel and lower it to remove ②.

9.2.2 REAR PANEL (GAS APPLIANCE)

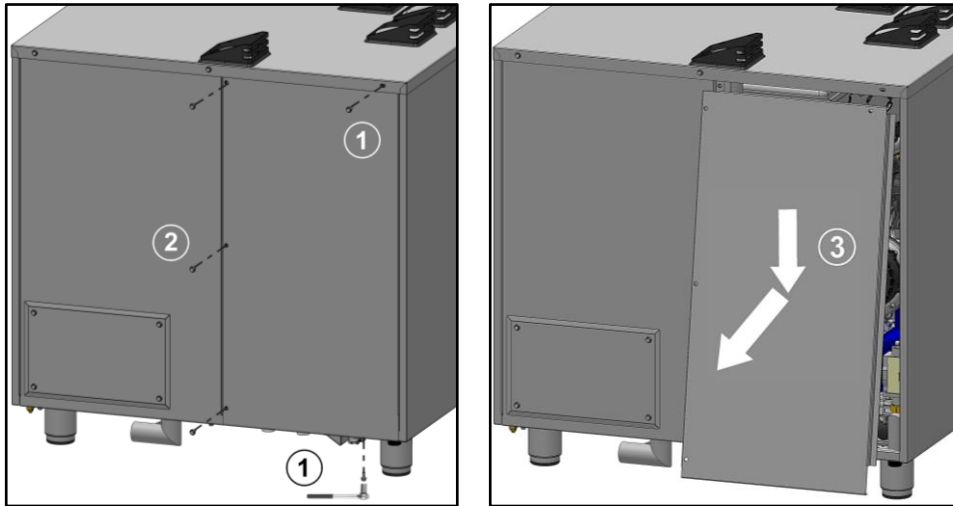

- » Prepare your intervention:
 - ✓ Tools: Wrenches.
- » Remove the left oven panel (► [Left side panel](#)).
- » Unscrew and remove the 2 x M5 screws securing the panel at the top and bottom ① and then the 3 x M5 screws securing the left-hand side of the half-panel ②.
- » Remove the half-panel: Unhook bottom of the half-panel then lower it to remove ③.

9.2.3 REAR HATCH (GREASE COLLECTION OPTION)

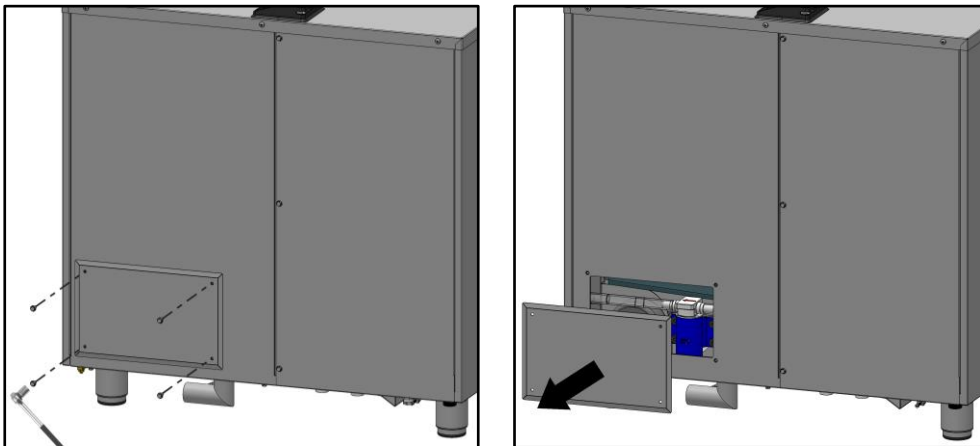

- » Prepare your intervention:
 - ✓ Tools: Wrenches.
- » Unscrew and remove the 4 x M5 screws securing the hatch cover to the rear panel.
- » Remove the hatch cover.

9.2.4 RUNNERS



- » Prepare the cooking cavity and check the following points:
 - ✓ Remove all trays, plates and grids from the cooking cavity
 - ✓ Verify the core probe has been removed from its housing

9 - ACCESS TO COMPONENTS

- ✓ Verify the USB core probe is not in the cooking cavity
- » Lift the runner slightly by the middle of one of the upper levels ①.
- » Tilt the runner towards the centre of the oven to release it from its lower supports (rear and front) ②.
- » Release the runner from its upper supports (front and rear) ③.
- » Remove the runner from cooking cavity ④.

9.2.5 VENTILATION DUCT

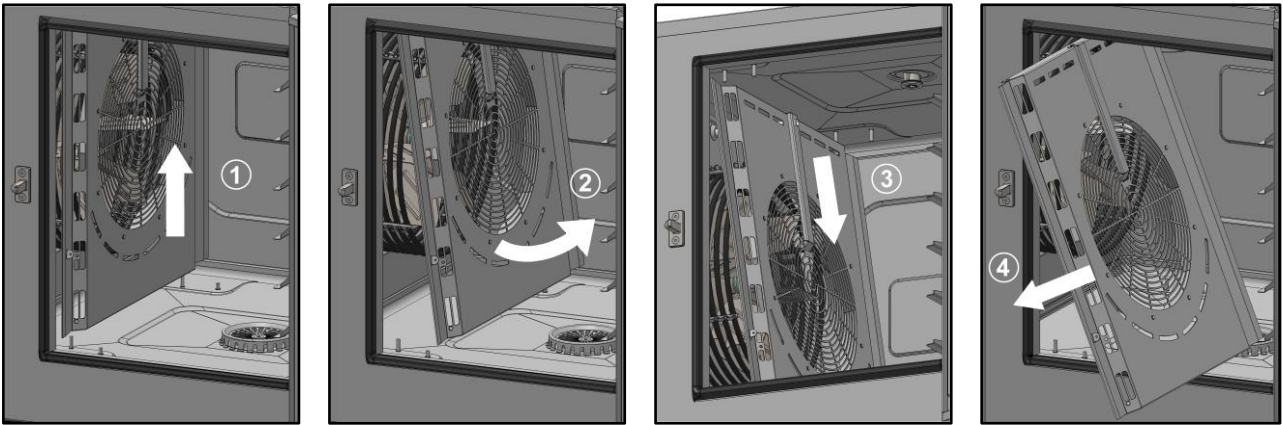

- » Prepare the cooking cavity and check the following points:
 - ✓ Remove all trays, plates and grids from the cooking cavity
 - ✓ Verify the core probe has been removed from its housing
 - ✓ Verify the USB core probe is not in the cooking cavity
 - ✓ Protect bottom of the cavity with board
- » Remove left-hand runner (► [Runners](#)).
- » Lift the duct slightly ①.
- » Tilt the duct to release it from its lower supports (rear and front) ②.
- » Release the duct from its upper supports (front and rear) ③.
- » Remove the duct from the cooking cavity ④.

9.2.6 MAINTENANCE POSITION OF THE MAIN BOARD

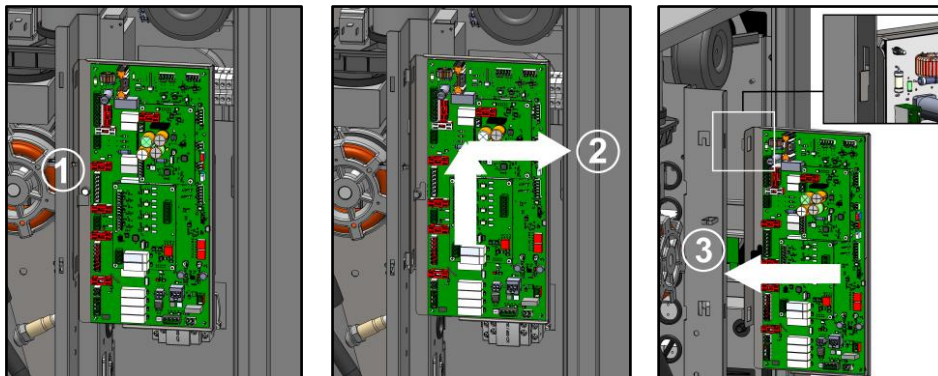

- » Prepare your intervention:
 - ✓ Tools: Wrenches
- » Remove the left oven panel (► [Left side panel](#)).
- » Slightly unscrew the screw securing the board to the electrical board ①.
- » Lift up and remove the main board ②.
- » Position the board in the 2 notches provided during maintenance operations ③.

10. COMPONENTS

10.1 ELECTRONIC BOARDS

10.1.1 MAIN BOARD - AR

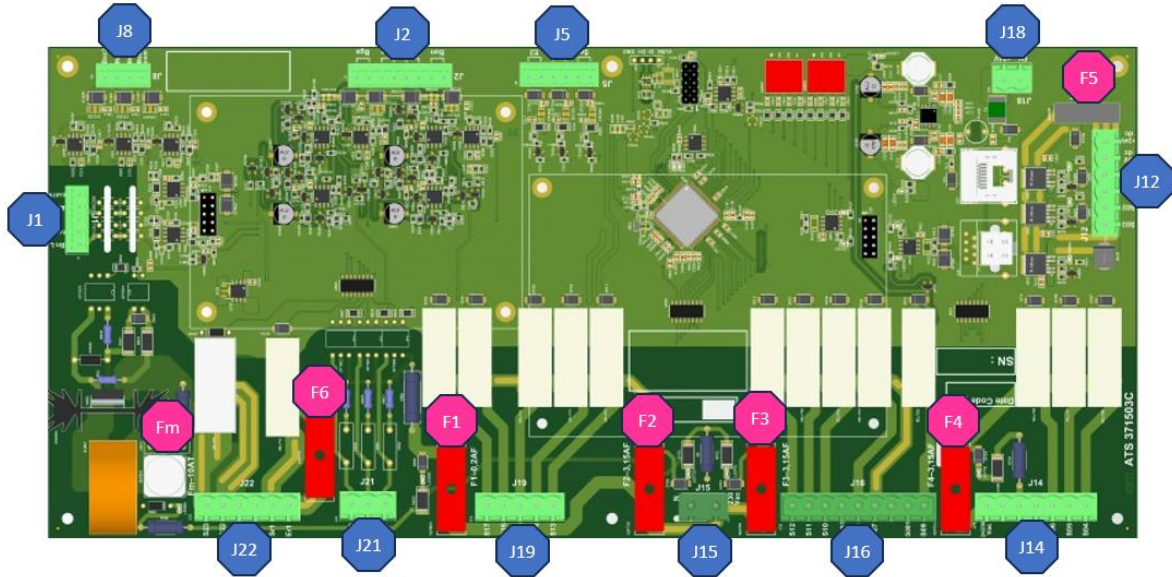

Fuse	Ref.*	Function	Caliber	Size
Fm	Fm	Ventilation motor protection	10A Time-delay	5x20
F1	F1	Solenoid valve protection	0,2A Fast	5x20
F2	F2	Wash pump solenoid valve protection	3,15A Fast	5x20
F3	F3	Protection of Heating, technical ventilation and gas board power supply	3,15A Fast	5x20
F4	F4	Pump protection	3,15A Fast	5x20
F5	F5	24Vdc service protection	4A Fast	ATC
F6	F6	Potential-free contact protection (hood)	6,3A Fast	5x20

* References on electrical diagrams.

Connectors	Nber of terminals	Color of wires	Destination	Function of the destination elements	Measurements
J1	2	Orange	BnL	Checks the water level in the cleaning box	
	5	G Y	Earth		
	3	NC			
	4	Orange	BnC	Checks the water level in the steam generator	
	5	G Y	Earth		
J2	1	Red	Bga	Measures steam generator temperature (safety input)	Value between 100 Ohms (35°F) and 212 Ohms (572°F)
	2	Red	Bga		
	3	White	Bgn	Measures steam generator temperature (control input)	Value between 100 Ohms (35°F) and 212 Ohms (572°F)
	4	White	Bgn		
	5	Red	Baa	Measures cavity temperature (safety input)	Value between 100 Ohms (35°F) and 212 Ohms (572°F)
	6	Red	Baa		
	7	White	Ban	Measures the ambient temperature of the cavity (control input)	Value between 100 Ohms (35°F) and 212 Ohms (572°F)
	8	White	Ban		
J5	1		E2		
	2		E2		
	3	Brown	E1	Grease collection pressure switch option	Normally closed contact
	4	Blue	E1		
	5	Brown	Sp	Control the closing of the door	
	6	Blue	Sp		
J8	1	Black	PT100Bsc3	Food temperature control (3 levels)	Value between 100 Ohms (35°F) and 212 Ohms (572°F) Take these mesures between Yellow wire and each other wire
	2	Red	PT100Bsc2		
	3	White	PT100Bsc1		
	4	Yellow	Bsc com.		
J12	1	Red	S03	Supplies the pump for the grease collection option	24Vd.c. with Tc-
	2	Red	S02	Supplies the In valve or the In valve contactor (20-level ovens only)	24Vd.c. with Tc-
		Red	S110	Supplies power to the LED lightning on the oven door (20-level ovens only)	24Vd.c. with Tc-
	4	Red	S01	Supplies power to the LED lightning on the oven door	24Vd.c. with Tc-
	5	Black	0Vd.c.	Not connected	



J14	6	Red	24Vd.c.	External power supply 24Vd.c. from Tc+	24Vd.c. with Tc-
	1	Purple	24/230Vac	supplies the 120Va.c pump.	120Vac with Nbt
	2	-			
	3	Blue	Nbt	common pump supply 120Va.c.(neutral)	120Vac with 24/230Vac
	4	-			
	5	Purple	Mdg - S06	activates the descaling pump 120Vac	120Vac with Nbt
	6	Brown	Mvm - S05	activates the 120Vac cavity drain pump	120Vac with Nbt
J15	7	Pink	Mvg - S04	activates the steam generator drain pump 120Vac	120Vac with Nbt
	1	Blue	Neutral	Supplies the 230Vac outputs	230Va.c. between these two points
J16	2	Purple	230Vac		
	1	Brown	Chauf Vap-S12	In an electric oven, activate the Kg steam generator heating contactor(s) In a gas oven, activates the steam generator burner	230Va.c. with neutral
		Red			
	2	Red	Chauf 2-S11	Not used in an electric oven In a gas oven, activates the heating burner (only 20 level oven)	230Va.c. with neutral
	3	Pink	Chauf 1-S10	In an electric oven, activate the Kr (green) control contactor(s) In a gas oven, activate the heating burner	230Va.c. with neutral
		Red			
	4	Orange	S081	In a gas oven, supplies the gas solenoid valves	230Va.c. with neutral
	5	Orange	Mtv1 - S08	Activates technical ventilation	230Va.c. with neutral
		Purple	Mtv1 - S08	Activates technical ventilation	230Va.c. with neutral
	6	Brown	Aag 230V - S07	Not used in electric ovens Supplies the gas card of gas ovens	230Va.c. with neutral
		-	-		-
J18	7	Purple	XeA-S091	Controls the energy saver (electric oven) Controls the second technical ventilation	230Va.c. with neutral
		W1- 3		Controls the rotation speed of the hood	
	9	Purple	S09	Activates the power contactor(s) Kp	230Va.c. with neutral
J19	1	Red	+24VSyst	24Vd.c. power supply for Main board	24Vd.c. between 1 and 2
	2	Black	0VSyst		
J21	1	Reserve	S17	Reserved	
	2	Brown	Ydescal. - S16	Activates the powder dissolution solenoid valve	230Va.c. with neutral
	3	Pink	Yspray - S15	Activates the spray hose solenoid valve	230Va.c. with neutral
	4	Brown	S14	Activate the motor Air inlet contactor (20 levels ovens only)	230Va.c. with neutral
	5	Purple	Cleaning pump - S13	Activates the cleaning pump	230Va.c. with neutral
J22	1	Pink	Yboiler- S20	Activates the injection solenoid valve	230Va.c. with neutral
	2	Brown	Ycool - S19	Activates the cooling solenoid valve	230Va.c. with neutral
	3	Pink	Ycond. - S18	Activates the condenser solenoid valve	230Va.c. with neutral
J22	1	Black	S23	Activates clockwise motor rotation	208Va.c. with Xm0 for 208Va.c. oven 240Va.c. with Xm0 for 240Va.c. oven 230Va.c. with Xm0 for 480Va.c. oven
	2	Red	S22	Activates anticlockwise motor rotation	208Va.c. with Xm0 for 208Va.c. oven 240Va.c. with Xm0 for 240Va.c. oven 230Va.c. with Xm0 for 480Va.c. oven
	3	Black	E21	Supplies power to the motor	208Va.c. with Xm0 for 208Va.c. oven 240Va.c. with Xm0 for 240Va.c. oven 230Va.c. with Xm0 for 480Va.c. oven
	4	-	-	-	
	5	W1-2	Sr1	Potential-free contact for hood motor control	Closed when the oven is operating
	6	W1-1	Er1		

10.1.2 HUMIDITY BOARD - AHU

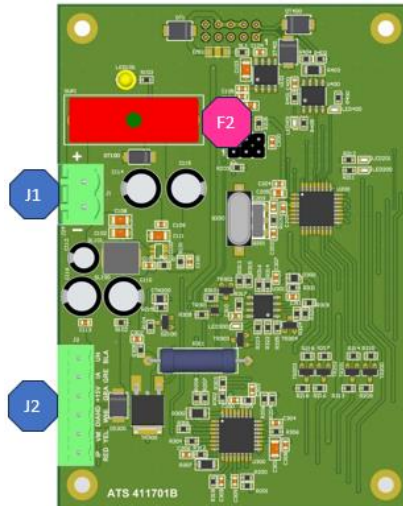

Fuse	Ref.*	Function	Caliber	Size
F2	F2	Protect Humidity board	3.15A	5X20

* References on electrical diagrams.

Connectors	Nber of terminals	Color of wires	Destination	Function of the destination elements	Measurements
J1	1	Red	Ahu/+	Humidity board power supply	24Vdc between these two points
	2	Black	Ahu/-		
J2	1	Black	Ah Blk	Supply humidity probe, heater unit and probe feedback	
	2	Violet	Ah Pure		
	3	Grey	Ah Gre		
	4	White	AhWhi		
	5	Orange	Ah Yel		
	6	Red	Ah Red		

10.1.3 GAS BOARD - AAG

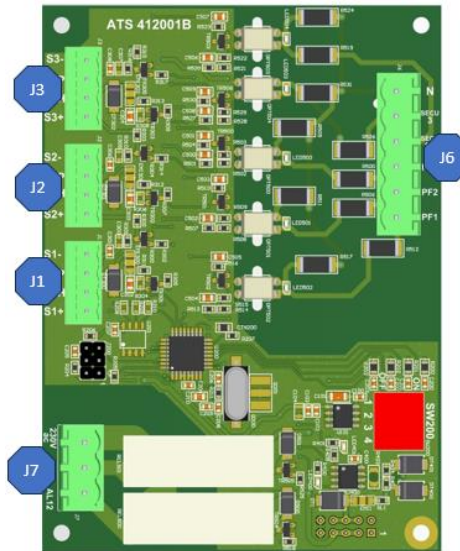

Connectors	Nber of terminals	Color of wires	Destination	Function of the destination elements	Measurements
J1	1	Black	GND/Alim- PWM	Convection heat burner fan control	
	2	Pink	S1P/PWM input		
	3	Orange	S1H/PWM Hall probe output		
	4	Red	+24Vdc/Alim+PWM		
J2	1	Black	GND/Alim- PWM	Convection heat burner fan control only 20 levels	
	2	Pink	S2P/PWM input		
	3	Orange	S2H/PWM Hall probe output		
	4	Red	+24Vdc/Alim+PWM		



J3	1	Black	GND/Alim- PWM	Steam generator burner fan control	
	2	Pink	S1P/PWM input		
	3	Orange	S1H/PWM Hall probe output		
	4	Red	+24Vdc/Alim+PWM		
J6	1	Blue	Neutral	Flame and safety burner check	Flame control feedback at 230Va.c.
	2	Grey	Secu3		
	3	Red	Secu 12		
	4	Brown	Pf3		
	5	Purple	Pf2		
	6	Purple	Pf1		
J7	1	Brown	230Vac	Burner ignition control	230Va.c. between 230Va.c. and Xb
	3	Brown	AL3		
	2	Purple	AL12		

10.1.4 INTERFACE BOARD - AI

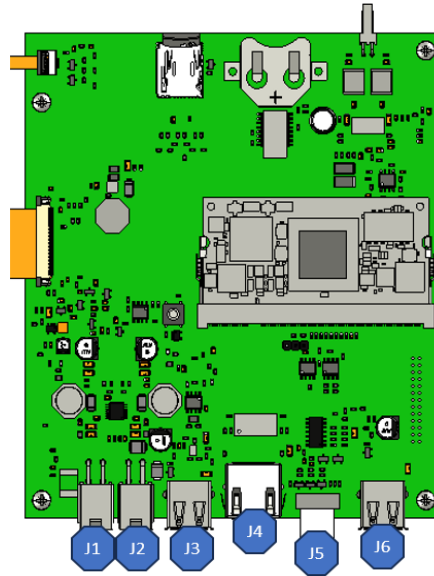

Connectors	Nber of terminals	Connectors type	Destination	Function of the destination elements	Measurements
J1		4-pin Molex connector		Not used	
J2		4-pin Molex connector		Connects to the Main board	
J3		USB connector		Connects the WIFI Dongle (Kit)	
J4		RJ45		Ensures customer network connection for connectivity	
J5		10-way ribbon connector 1.27mm pitch AWG28		Connects coder board to interface board	
J6		USB connector		Connects front USB socket	

10.1.5 CODER

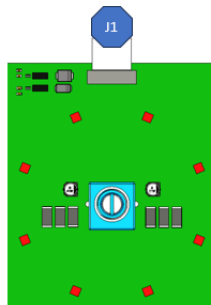

Connectors	Nber of terminals	Connectors type	Destination	Function of the destination elements	Measurements
J1		10-way ribbon cable 1.27mm pitch AWG 28		Connects coder board to the interface board	



10.2 ELECTRIC BOARDS

Electric ovens

Gas ovens

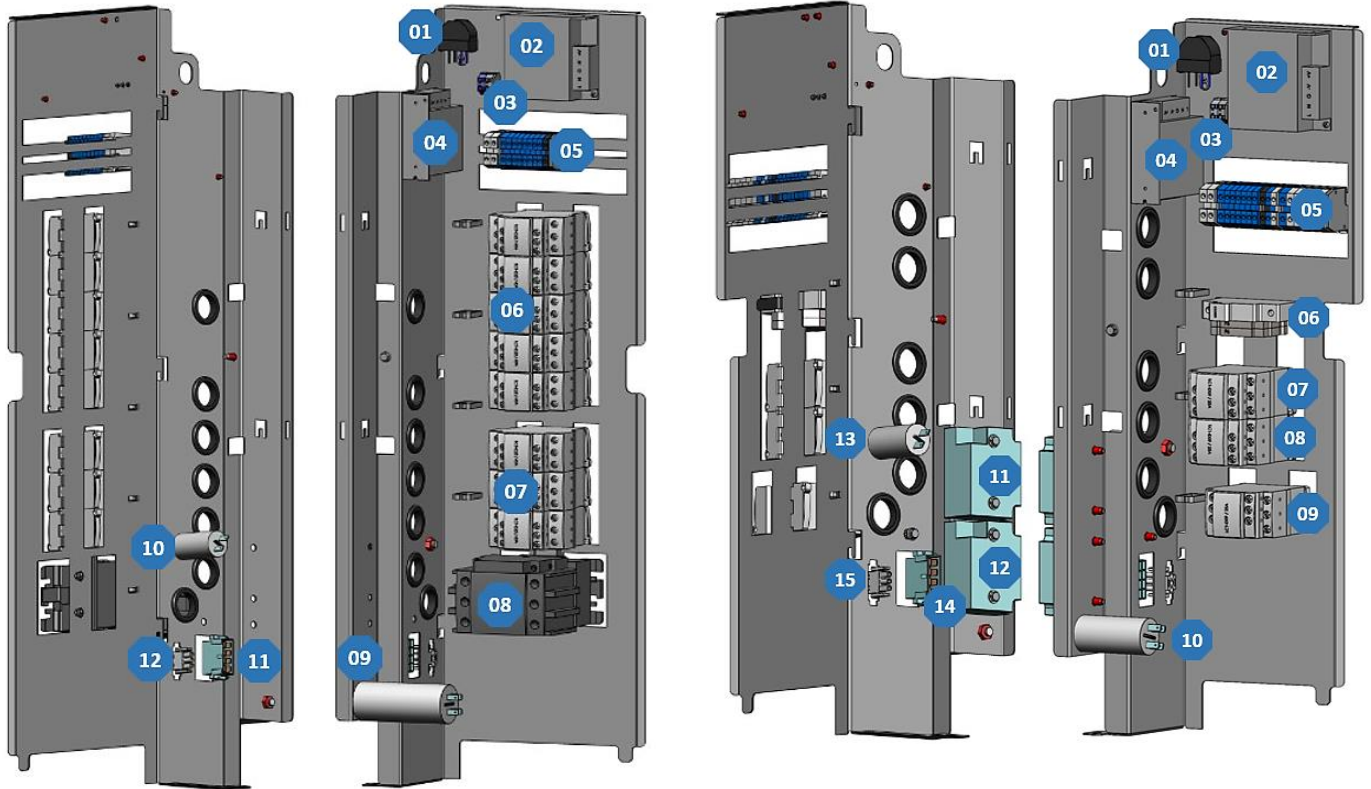

Electric ovens

Item	Ref.*	Description	Functions
1	La	EMC filter	Limits electromagnetic interference
2	Ta	Switching power supply	Supplies 24Vdc to services (lighting, In valve solenoid, grease gun)
3	Xe	Lighting terminal block	Connects LED strips for oven lighting
4	Tc	Switching power supply	Supplies 24Vdc to the Main board
5	X	Terminal block (Xa, Xb, X+, X-, Xm0, Xm1)	Connects the various power supplies
6	Kr	Convection heat control contactor	Supplies the heating elements with convection heat
7	Kg	Steam generator heating contactor	Supplies steam generator immersion heaters
8	Kp	Power contactor	Controls power to the oven
9	Cvm	Cooling fan	Starts the cooling fan
10	Cpl	Wash pump capacitor	Starts the wash pump
11	Xmv	Fan motor connector	Connects the fan motor to the board
12	Xpl	Wash pump connector	Connects the wash pump to the board

* References on electrical diagrams.

Gas ovens

Item	Ref.*	Description	Functions
1	La	EMC filter	Limits electromagnetic interference
2	Ta	Switching power supply	Supplies 24Vdc to services (lighting, In valve solenoid, grease gun)
3	Xth	Lighting terminal block	Connects LED strips for oven lighting
4	Tc	Switching power supply	Supplies 24Vdc to the Main board
5	X	Terminal block (Xa, Xb, X+, X-, Xm0, Xm1)	Connects the various power supplies
6	F	Protections (Ftco, Ftvb, Ftmv)	Protects the transformer and fan motor outputs (US model only)
7	Kr	Convection heating control switch	Controls the convection heater burner control board (1 or 2 depending on the oven model)
8	Kg	Steam generator contactor	Controls the steam burner regulation board
9	Kp	Power contactor	Controls power to the oven
10	Cm	Cavity fan capacitor	Starts the cavity ventilation motor
11	Ear	Convection heating ignition transformer	Ignites the convection burner electrode (1 or 2 depending on the oven model)
12	Eag	Steam generator ignition transformer	Ignites the steam generator burner electrode
13	Cpn	Wash pump capacitor	Starts the wash pump
14	Xm	Fan motor connector	Connects the fan motor to the board
15	Xpn	Wash pump connector	Connects the wash pump to the board

* References on electrical diagrams.



10.3 OTHER COMPONENTS

10.3.1 ELECTRIC OVENS

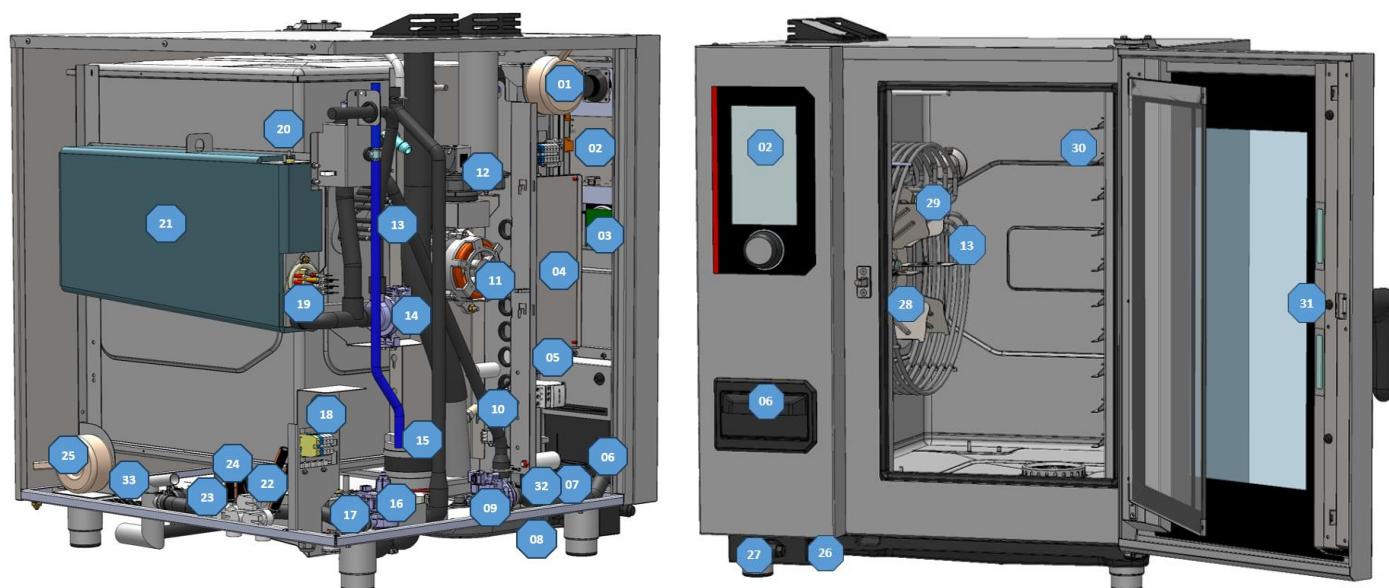

Item	Ref.*	Description	Functions
1	Tco	Control auto transformer	(On certain models only) Ensures that customer voltage can be matched to oven operating voltages
2	Ai	Interface board	Human-machine interface
3	Ac	Encoder board	Human-machine interface
4	Ar	Main board	Control all oven components
5	-	Electrical board	Provides the link between Main board commands and the functions of external components
6	-	Descaling box	Contains descaling powder
7	Mt1-2	Technical fan	Ensure forced ventilation of the technical compartment
8	-	Spray hose reel	Contains spray hose reel
9	Mdg	Steam generator descaling pump	Ensures circulation of steam generator descaling agent
10	Shu	Humidity sensor	Humidity control
11	M1	Cavity fan motor	Ensures turbine rotation
12	Lo	Air inlet valve	Controls air inlet valve movements
13	Rc	Convection heating elements	Heats the inside of the cavity (several depending on model)
14	Mvg	Steam generator drain pump	Drain water from steam generator
15	Mpn	Cleaning pump	Ensures water circulation during cleaning phases
16	Mvm	Cavity drain pump	Ensures the draining of liquid elements contained in the cavity
17	Bnl	Clean box water level probe	Controls water level in clean box
18	Xp	Power terminal block	Allows the oven to be connected to the customer's electrical network
19	Rg + Bg	Steam generator immersion heater + Temperature probe	Heats the water contained in the steam generator, the sensor controls the water temperature in the steam generator (safety and regulation circuits).
20	Bnc	Steam generator water level probe	Controls water level in steam generator
21	-	Steam generator	Produce steam
22	Ycool - Yboiler - Ydescal.	Triple solenoid valve	Controls filtered water supply cooling, steam generator filling and descaling
23	Yspray - Ycond	Double solenoid valve	Controls unfiltered water inlet for spray hose and condenser
24	-	Clean box	Collects liquid elements contained in the cavity
25	Tmv	Cavity fan motor autotransformer	(On some models only) Adapts customer voltage to the voltage used by the cavity fan motor
26	-	USB socket	Allows connection of a USB key for updates, backups, etc.
27	-	Spray hose	Cleans the oven
28	Ba	Cavity temperature probe	Controls oven cavity temperature (safety circuits and regulation)
29	M1	Fan	For even heat distribution
30	Bsc	3-point food core probe	Allows food temperature to be taken
31	Ee1 - Ee2	LED strips	Provide interior oven lighting (number depends on model)
<i>Grease collection option</i>			
32	P	Pressure switch	Check no over pressure in the circuit.
33	Mpg	Grease pump	Drain grease from the cavity.

*References on electrical diagrams.

10.3.2 GAS OVENS



Item	Ref.*	Description	Functions
1	Tco	Control auto transformer	(On certain models only) Ensures that customer voltage can be matched to oven operating voltages
2	Ai	Interface board	Human-machine interface
3	Ac	Encoder board	Human-machine interface
4	Ar	Main board	Controls all oven components
5	-	Descaling box	Contains descaling powder
6	Mt1	Technical fan	Ensures forced ventilation of the technical compartment
7	-	Spray hose reel	Contains spray hose reel
8	Mdg	Steam generator descaling pump	Ensures circulation of steam generator descaling agent
9	Shu	Humidity sensor	Humidity control
10	-	Electrical board	Provides the link between Main board commands and the functions of external components
11	M1	Cavity fan motor	Ensures turbine rotation
12	Lo	Air inlet valve	Controls air inlet valve movements
13	Mbr	Convection-heating burner motor	Supplies oxygen to the flame
14	Mbg	Steam generator burner motor	Supplies oxygen to the flame
15	Avr-1	Connection box of solenoid valve for convection gas heating	Controls the solenoid valve for the gas supply to the convection-heating burner
16	Mpn	Cleaning pump	Ensures water circulation during cleaning phases
17	Mvm	Cavity drain pump	Ensures the draining of liquid elements contained in the cavity
18	Bnl	Clean box water level probe	Controls water level in clean box
19	Avg	Connection box of solenoid valve for steam generator gas control	Controls the solenoid valve of the gas supply to the steam generator burner
20	Xp	Power terminal block	Allows the oven to be connected to the customer's electrical network
21	Ycool - Yboiler - Ydescal.	Triple solenoid valve	Controls filtered water supply cooling, steam generator filling and descaling
22	Yspray - Ycond	Double solenoid valve	Controls infiltrated water inlet for spray hose and condenser
23	-	Clean box	Collects liquid elements contained in the cavity
24	Mvg	Steam generator drain pump	Drain water from steam generator
25	Bg	Steam generator temperature probe	Controls temperature of the water in the steam generator (safety circuit and regulation)
26	Bnc	Steam generator level probe	Controls water level in steam generator
27	-	Steam generator	Produce steam
28	Tmv	Cavity fan motor autotransformer	(On some models only) Adapts customer voltage to the voltage used by the cavity fan motor
29	-	USB socket	Allows connection of a USB key for updates, backups, etc.
30	-	Spray hose	Cleans the oven
31	Ba	Cavity temperature probe	Controls oven cavity temperature (safety circuit and regulation)
32	M1	Fan	For even heat distribution
33	-	Gas exchanger	Heats the oven interior
34	Bsc	3-point food core probe	Allows food temperature to be taken
35	Ee1, Ee2	LED strips	Provide interior oven lighting (number depends on model)
Grease collection option			
32	P	Pressure switch	Check no over pressure in the circuit.
33	Mpg	Grease pump	Drain grease from the cavity.

*References on electrical diagrams.

11. RECOMMENDED AND EMERGENCY SPARE PARTS
--

Code	Vulcan Code	Description	Category
145587	00-977003	Drive shaft gasket + wear ring	Wearing Part
147147	00-978115	120W UL Motor service kit + ring + gasket	Recommended Part
148885	00-978275	Arched ignition electrode	Wearing Part
148886	00-978276	Straight Ionisation electrode	Wearing Part
148889	00-978277	Flame control electrode	Recommended Part
159005	00-978291	ICS24-61E - Service Kit Round heating element 11.2kW 230/240V	Recommended Part
159007	00-978292	ICS24-6~102E - Service Kit Round heating element 23.5kW 230/240V	Recommended Part
159008	00-978293	ICS24-101E - Service Kit Round heating element 19.6kW 230/240V	Recommended Part
159009	00-978294	ICS24-102E - Service Kit Round heating element 15.2kW 230/240V	Recommended Part
159010	00-978295	ICS24-61E - Service Kit Round heating element 10.3kW 208V	Recommended Part
159012	00-978296	ICS24-6~102E - Service Kit Round heating element 21.6kW 208V	Recommended Part
159013	00-978308	ICS24-101E - Service Kit Round heating element 18kW 208V	Recommended Part
159014	00-978298	ICS24-102E - Service Kit Round heating element 14kW 208V	Recommended Part
159015	00-978299	ICS24-61E - Service Kit Round heating element 10.3kW 277V	Recommended Part
159017	00-978300	ICS24-6~102E - Service Kit Round heating element 21.6kW 277V	Recommended Part
159018	00-978301	ICS24-101E - Service Kit Round heating element 18.0kW 277V	Recommended Part
159019	00-978302	ICS24-102E - Service Kit Round heating element 14kW 277V	Recommended Part
159022	00-978303	ICS24-61E - Service Kit Immersion heater 9,8kW 230/240V	Recommended Part
159023	00-978304	ICS24-6~10E - Service Kit Immersion heater 19.1kW 230/240V	Recommended Part
159024	00-978305	ICS24-61E - Service Kit Immersion heater 9kW 208V	Recommended Part
159025	00-978306	ICS24-6&10E Service Kit Immersion heater 17,5kW 208V	Recommended Part
159026	00-978307	ICS24-61E - Service Kit Immersion heater 9kW 277V	Recommended Part
159027	00-978308	ICS24-6~10E - Service Kit Immersion heater 17.5kW 277V	Recommended Part
159028	00-978309	ICS24-6&10E - Service Kit Temperature sensor	Recommended Part
159030	00-978311	ICS24 - Service Kit Ambient sensor	Recommended Part
159032	00-978313	ICS24 GN21 - Service Kit Motor	Recommended Part
159046	00-978325	ICS24-G- Service kit Gas fan NG40	Recommended Part
159048	00-978270	ICS24-61 - Service Kit Core temperature probe	Recommended Part
159049	00-978271	ICS24-102 - Service Kit Core temperature probe	Recommended Part
159050	00-978272	ICS24-62&101 - Service Kit Core temperature probe	Recommended Part
159053	01-556342	IC24-61&101 - Service kit for descaling pump	Recommended Part
159054	01-556343	IC24-62&102 - Service kit for descaling pump	Recommended Part
159060	01-556309	ICS24 - Service kit Fuses UL	Recommended Part
159064	01-556328	Kit after-sales service pressure switch	Recommended Part
159065	01-556370	ICS24-61&101 - Service Kit TPE-S AL Transparent pipe	Wearing Part
159066	01-556371	ICS24-62&102 - Service Kit TPE-S AL Transparent pipe	Wearing Part
300697	00-978061	Three-pole 25A 230V 50/60 Hz contactor	Recommended Part
300698	00-977007	Three-pole 32A 230V 50/60 Hz contactor	Recommended Part
300699	00-977375	Three-pole 40A 230V 50/60 Hz contactor	Recommended Part
300702	00-978065	Tree-pole 80A 230V 50/60 HZ contactor	Recommended Part
300769	00-977008	Anti-interference relay	Recommended Part
300787	00-977009	Ultra fast fuse 0.2A 250V 5 x 20	Recommended Part
300793	00-977014	600VAC fuse 10A 10.3 x 38.1	Recommended Part
300798	00-978062	Three-pole contactor 125A 230V 50/60 HZ	Recommended Part
300799	00-978064	Block RC LA4DA2U	Recommended Part
300801	00-978059	Glass fuse 4A	Recommended Part
300802	01-556134	Integrated switching power supply	Recommended Part
300805	00-978339	ICS24 - Door reed	Recommended Part
300806	00-978340	ICS24 - Door reed	Recommended Part
301514	00-978341	ICS24-6&10E - Boiler level sensor	Recommended Part
301515	00-978342	ICS24 - Humidity probe	Recommended Part
301519	00-978345	ICS24 - Wash box level probe	Recommended Part
301520	00-978346	ICS24-102E - Boiler level sensor	Recommended Part
304296	00-977018	Condenser 12.5µf	Recommended Part
304314	01-556135	Grease pump and fitting for hose diameter13	Recommended Part
304317	00-978350	ICS24 61E - Fan wheel	Recommended Part
304321	00-978351	ICS24 - Descaling pump 120V UL 60HZ 20L/min	Recommended Part
304322	00-978352	ICS24 - Drain pump wash box 120V UL 60HZ 20L/min	Recommended Part
304323	00-978353	ICS24 - Pump 120V UL 60HZ 20L/min	Recommended Part
304326	00-978354	ICS24 GN21 - Capacitor 25µ	Recommended Part
304328	00-978355	ICS24 61G 101E - Fan wheel 320	Recommended Part
304329	00-978356	ICS24 62E 101G - Fan wheel 340	Recommended Part
304330	00-978357	ICS24 62G 102E - Fan wheel 370	Recommended Part
304331	01-556310	ICS24 102G - Fan wheel 390	Recommended Part
304334	00-978358	ICS24 - Fan UL 230V 120 x 120 x 38 mm	Recommended Part
308353	00-978370	ICS24 - Switching power supply 24V 35W	Recommended Part
309407	00-977024	Fuse 3.15 Amps	Recommended Part
309608	00-978132	Filter with connection for gas oven	Recommended Part
309714	00-978375	FastPad 3 Interface Unit	Recommended Part
309716	00-978376	FastPad 3 Illuminated Optical Encoder	Recommended Part
309717	00-978377	FastPad 3 Gas board	Recommended Part

Code	Vulcan Code	Description	Category
309718	00-978378	FastPad 3 Humidity board	Recommended Part
309719	00-978379	Led Strip 4000K 24V	Recommended Part
309720	00-978380	Automate board + Humidity board	Recommended Part
309725	00-978383	SELF common mode 2x10	Recommended Part
310356	00-978145	Security box	Recommended Part
310358	00-978386	Electromagnet GY030 24V	Recommended Part
311356	00-977221	LED strip label	Wearing Part
311361	00-977218	LED strip protective film	Recommended Part
314396	00-978083	UL Wash pump	Recommended Part
316192	01-556137	Transparent TPE-S AL Hose 12.7 x 20.1mm	Wearing Part
366068	00-978078 / 00-978096	Transparent silicone tube	Wearing Part
366572	00-977033	Door stop	Wearing Part
366683	00-978139	Outlet seal exchanger 6/10 levels	Wearing Part
366685	00-978152	Gas fan gasket	Wearing Part
366688	01-556144	FKM gasket 17,12x2,62mm	Wearing Part
366698	00-978432	ICS24-61 - Cooking cabinet gasket	Wearing Part
366699	00-978433	ICS24-62 - Cooking cabinet gasket	Wearing Part
366700	00-978434	ICS24-101 - Cooking cabinet gasket	Wearing Part
366701	00-978435	ICS24-102 - Cooking cabinet gasket	Wearing Part
366711	00-978441	ICS24 - Gasket In flap	Wearing Part
366712	00-978442	ICS24-GN11E - Immersion heater gasket	Wearing Part
384183	00-977034	Door closure mechanism	Recommended Part
384677	00-977035	Moulded door catch	Wearing Part
407002	00-978066	Anti-parasite module	Recommended Part
408402	00-978136	Gas ignition	Recommended Part
408407	00-978511	Auto Transformer 415 VA	Recommended Part
416003	00-978513	ICS24 - Hand shower kit	Wearing Part
468105	00-978545	ICS24 - Sub-assembly UL 2-way solenoid valve	Recommended Part
468107	00-978546	ICS24 - Sub-assembly UL 3-way solenoid valve	Recommended Part

12. COMBUSTION GAS ANALYSIS PROCEDURE

WHO (can carry out this procedure):

Expert Technician (Trained on Combis – Trained for this Procedure)

EQUIPMENT (tool required):

Combustion Analyzer, complying with the local regulations, and:

- Analyzer technology should be with onboard CO₂ probe (direct measure)
- If analyzer technology doesn't have a CO₂ probe (%CO₂ = calculation), check that the correct gas has been set in the analyzer, for the measure (mandatory for correct calculation)

WHEN (to do this procedure):

To switch from one gas to another

After changing Key Gas components as: Burner, Valve, Motor, Jet and exchanger



Procedure:

The procedure is shown in 16 steps:

- PARAMETERS screen: Selecting 'CO₂ rate & adjustment'.
- Confirmation dialog: 'Are you sure you want to start CO₂ control?' with 'START' button.
- CO₂ CONTROL screen: Selecting 'GAS' and 'GA'.
- CO₂ CONTROL screen: Pressing 'START'.
- CAVITY CONTROL screen: Pressing 'CONTINUE'.
- CAVITY CONTROL screen: 'Please open the door to continue'.
- CAVITY CONTROL screen: Pressing 'VALIDATE'.
- CAVITY CONTROL screen: 'CONTROL / ADJUSTMENT 1 (small speed)'.
- CAVITY CONTROL screen: Pressing 'VALIDATE'.
- CAVITY CONTROL screen: 'CONTROL / ADJUSTMENT 2 (small speed)'.
- CAVITY CONTROL screen: Pressing 'VALIDATE'.
- CAVITY CONTROL screen: 'CONTROL / ADJUSTMENT 3 (small speed)'.
- CAVITY CONTROL screen: Pressing 'VALIDATE'.
- BOILER CONTROL screen: Pressing 'CONTINUE'.
- BOILER CONTROL screen: Pressing 'VALIDATE'.
- BOILER CONTROL screen: Pressing 'END'.

Diagram 1: Probe insertion into gas chimney. Height requirement: $H > 2" / 50mm$. Warning: The probe must be inserted into the gas chimney to measure combustion values.

Diagram 2: Probe insertion into boiler chimney. Height requirement: $H > 2" / 50mm$. Warning: The probe must be inserted into the gas chimney to measure combustion values.

Prepare your check:

- ✓ Oven is connected to the water and wastewater systems, the electrical system and the gas supply line in accordance with the recommendations and guidelines described in this manual.
- ✓ Measuring instrument for monitoring carbon dioxide CO₂ and carbon monoxide CO.
- » Set the measuring instrument to "CO₂" for a calculation result of "CO₂ rate in %".



- » From the "Home" menu screen, select "Settings" button.
 - ⓘ The screen displays the "Parameters" menu with the "User" tab selected.
- » Select "Service" tab.
 - ⓘ The PIN code identification pop-up appears.
- » Enter the PIN code (level 7) to access "Service" parameters (▶ [Settings](#) - PIN Codes).
- » Confirm by pressing "✓" icon. If the code is correct, access to the screen is authorised; if not, return to entering the PIN code.
 - ⓘ The screen displays the "Parameters" menu with the "Service" tab displayed.
- » Press "CO₂ control & adjustment" button.
- » Confirm by pressing « ✓ » icon.
 - ⓘ The "CO₂ control" screen appears.
- » Verify gas type matches the oven's supply gas.
- » Start test by pressing the "Start" button.
- » Place probe of the gas testing appliance in the cooking cavity flue gas chimney.
- » Open the oven door.
- » Press "Continue" button.
- » Follow the information displayed on the oven screen and confirm by pressing « ✓ » icon if the measurement values are correct.
 - ⓘ The percentage of CO₂ measured must correspond within +/- 0.2% to the required value for the gas type in the table below.
 - ⓘ Each check is performed on 3 measurement readings.

Burner Convection heat	CO ₂ (%) – Low speed			
	61	62	101	102
Gas A	10.4 ±0.2	10.7 ±0.2	10.1 ±0.2	10.0 ±0.2
Gas E	11.5 ±0.2	11.5 ±0.2	11.5 ±0.2	11.7 ±0.2

Burner Convection heat	CO ₂ (%) – High speed			
	61	62	101	102
Gas A	10.3 ±0.2	10.4 ±0.2	9.9 ±0.2	10.1 ±0.2
Gas E	11.5 ±0.2	11.8 ±0.2	11.6 ±0.2	11.8 ±0.2

Burner (Generator) Steam heat	CO ₂ (%) – Low speed			
	61	62	101	102
Gas A	10.6 ±0.2	10.4 ±0.2	9.5 ±0.2	9.5 ±0.2
Gas E	11.4 ±0.2	11.7 ±0.2	10.9 ±0.2	11.7 ±0.2

Burner (Generator) Steam heat	CO ₂ (%) – High speed			
	61	62	101	102
Gas A	10.2 ±0.2	10.3 ±0.2	9.7 ±0.2	9.6 ±0.2
Gas E	11.6 ±0.2	11.4 ±0.2	11.1 ±0.2	11.7 ±0.2

- » "If the percentage of CO₂ measured does not correspond to that requested for the gas used in the table above, adjust the setting screws.
- » Remove the left side panel to access the gas valves (▶ [Access to components](#) – Left-hand side panel).
- » Adjust the CO₂ adjustment screw on the gas valve to set the CO₂ to « Low speed »:
 - Remove the protective cap from the adjustment screw
 - Adjust the setting by screwing/unscrewing the screw using a 4mm Allen key or Torx T25, **a maximum of one turn at a time** (1% = 1 turn).
 - ⓘ Turn clockwise to increase the CO₂ level and anticlockwise to decrease the CO₂ level.
 - After adjustment replace the protective cap.
- » Adjust the RQ adjustment screw on the gas valve to set the CO₂ to « High speed »:
 - Adjust the setting by screwing/unscrewing the screw using a 2.5mm Allen key or Torx T10, **a maximum of a quarter turn at a time**.
 - ⓘ Turn clockwise to decrease the CO₂ level and anticlockwise to increase the CO₂ level.

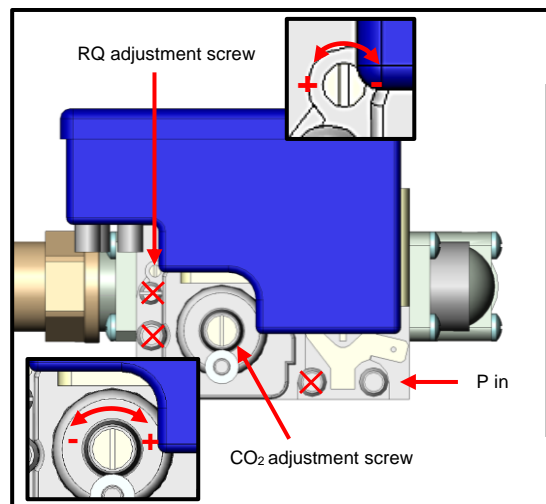
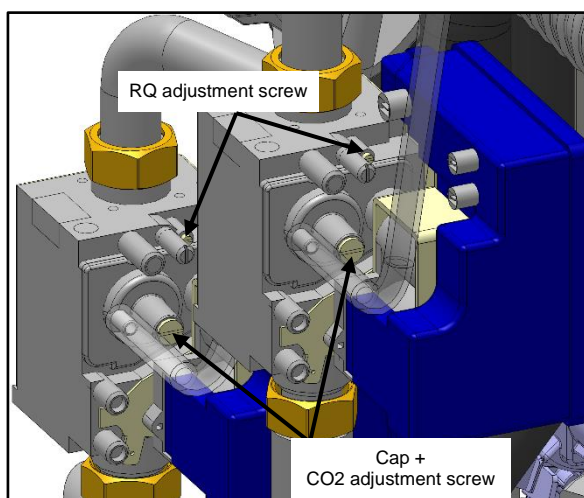

- » Follow "step by step" the actions displayed on the oven screen, validating if the measurement values are correct at each step up to step 9.
- » Place the probe of the gas testing appliance in the steam generator flue gas chimney.
- » Close the oven door.
- » Press the "Continue" button.
- » Follow the information displayed on the oven screen and confirm by pressing the « ✓ » icon if the measurement values are correct. If not, adjust the RQ or/and CO₂ adjustment screw on the corresponding gas valve, then confirm by pressing the « ✓ » icon.
- » When the display shows "Full control / adjustment achieved", press "End" to return to the previous screen.

13. CONTROL OF THE ELECTRODES (GAS BURNER)



WHO (can carry out this procedure):
Expert Technician (Trained on Combis – Trained for this Procedure)

EQUIPMENT (tool required):

- A rod / gauge by 0.24" diameter for the 3 electrodes (detection and flame detection).
- A rod / gauge by 0.12" (passes) and 0.16" (doesn't pass) diameters for ignition electrodes.

WHEN (to do this procedure):
In case of unusual noise from burners (loud ignition, detonation, etc.),

Procedure:

- » Record the noise,
- » Note the Serial Number (see data plate),
- » Remove the burner and control the position of ignition and flame detection electrodes (see drawing below):
 - A wrong electrodes' adjustment is the main reason to have abnormal noise.
 - No need to check the combustion (except after changing some gas circuit components) or, worse, change the combustion settings (screw ...).
- » Before changing anything in the Electrodes positions/ adjustments, take picture and measure the related positions (2 dimensions in the drawing bellow), and note any potential visible issue (deposits? ...).
- » Proceed to the setting / adjustment of the electrodes if out of the tolerances (see drawing). Change the electrodes if needed.

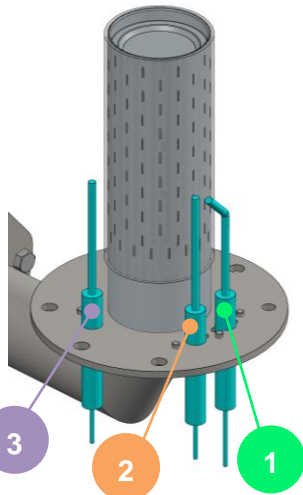

Convection heating burner

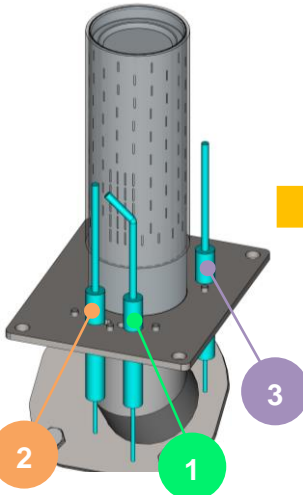

Steam generator burner

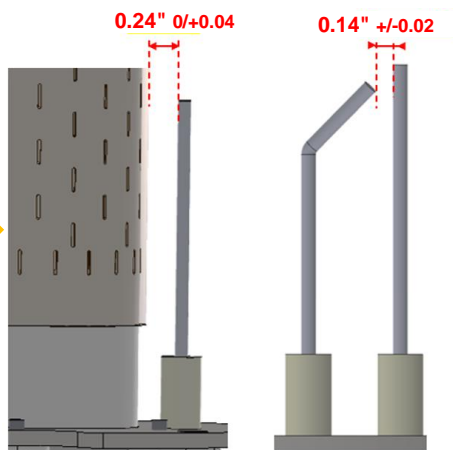

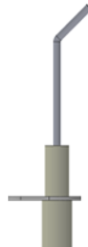

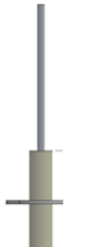
N°	1	2	3
Type	Ignition	Ignition	Flame detection
Code	148885	148886	148889
Visual			

- » Reassemble the burner / gas circuit and validate that the noise problem is resolved.
- » Send all information to TECHNICAL SUPPORT: Serial Number, Gas & pressure, Noise record, setting before any change, settings after change if needed ... and global validation.



14. CHANGING THE EQUIPMENT FROM ONE GAS TO ANOTHER

The change of gas type can only be carried out by a technician authorised and trained by manufacturer, or by our local representative.



Before any intervention, check with the owner which gas is currently in use in the kitchen.

Ensure that you are equipped with suitable measuring instruments (product analysis, gas water column pressure gauge, gas leak detector etc.) and that they are in full working order. Without these instruments it is prohibited to carry out any gas-related maintenance or adjustment!

Note : Connection/disconnection of the gas supply, as well as any maintenance or interventions are subject to the local legislation in force.

In the following chapters, the different gases are designated by their international codification:

Gas A	NATURAL GAS
Gas E	PROPANE

14.1 GAS FLOW RATES AND POWERS

	Gas power		Gas flow rates	
	Gas A	Gas E	Gas A	Gas E
	<i>Btu/h</i>	<i>Btu/h</i>	6.5 - 10 inch w.c. <i>ft³/h</i>	10 - 15 inch w.c. <i>lb/h</i>
VICS61G / CHEF-61G	58006	54594	53.89	2.59
VICS62G / CHEF-62G	112601	102364	104.61	4.86
VICS101G / CHEF-101G	93834	88716	87.17	4.21
VICS102G / CHEF-102G	143310	136144	133.14	6.46

14.2 CHART OF GAS INJECTORS

	GAS			INJECTORS		
	Designation		Pressure inch w.c. (mbar)	Qty	Ø (1/100 ^e)	Code
	Family	Type				
Burners Convection heat and Steam heat	Natural gas	Gas A	6.5 – 10 (16 – 25)	-	-	-
	Propane	Gas E	10 – 15 (25 – 38)	1	580	148 799

14.3 CHANGEOVER FROM ONE GAS TO ANOTHER:



Warning: Risk of poisoning!

When in use, connecting the wrong type of gas and/or setting the burners incorrectly can lead to a serious risk of intoxication.

Connect the appliance only to the type of gas used.

Check that the appliance settings correspond to the type and pressure of the gas in the installation.

Carry out a flue gas analysis when the appliance is commissioned for the first time.

We recommend installing a CO detector at the installation site.



The oven is equipped with 2 gas burners: one for convection heating and one for the steam generator. It is essential to analyse the combustion gases at the outlet of the two chimneys.



Caution: Gas leaks = danger for the user!

Check for leaks: This is a standard procedure and is your responsibility.

Notice

- The gas connection must be carried out by a qualified and certified gas fitter.
- Check that the appliance settings correspond to the type and pressure of the gas supplied to the installation.
- The gas connection pipe must be sized according to the nominal heat output and type of gas indicated on the nameplate. The cross-section of the gas pipe must be at least 3/4".
- Connect the appliance to the gas supply pipe using a shut-off valve to isolate the appliance from the rest of the installation.
- Flue gas extraction must comply with local regulations.
- Flue gas analysis must be carried out before commissioning and only by a technician approved by the manufacturer.
- Check the gas supply for leaks using a suitable gas detector.
- All connecting parts on the installation site must be certified for gas use (e.g. NF gas; DVGW).
- A gas appliance with a mobile base must be installed using:

In EU: "Flexible gas approved in accordance with the regulations in force. (eg : NF TUBOGAZ length 0.75 m, Ø 15/21 (1/2"))" without flexible coupling, to be examined periodically and replaced if necessary.

In US: a connector that complies with the current standard (ANSI Z21.69 - CSA 6.16 US) (standard relating to connectors for mobile gas appliances) and a quick disconnection device that complies with the current standard (ANSI Z21.41 - CSA 6.9 US) (standard relating to quick disconnection devices for use with gaseous fuel)

Table of actions when switching from one gas to another:

According to the country of installation and the category of the appliance (indicated on the firm plate), the adaptation from one gas to another may require 2 operations:

- IN:** Addition or removal of injector
(Convection heat and steam burners (steam generator))
- RV:** Gas valve adjustment (CO2 rate)

Research into the operations required to change gas:

- » On the appliance firm plate, check:
 - The category (ies) of the equipment.
 - The gas and pressure for which it is adjusted.
- » In the following chart, select
 - The country concerned.
 - The gas and the category of the appliance (previously identified)
 - The gas and the pressure for which the appliance is going to be adjusted
 - Identify the operations required when changing gas.

Countries concerned	Category and GAS OF ORIGIN (or new gas)	NEW GAS and Category (or gas of origin)	Required operations
	Gas	Gas	
US - Canada	Gas A	Gas E	IN + RV

Procedure:

Prepare your connection and check the points below:

- ✓ A shut-off valve is fitted to isolate the appliance from the rest of the installation.
- ✓ The appliance is installed in the space provided.
- ✓ The appliance is securely positioned to avoid any risk of slipping.
- ✓ The appliance settings correspond to the type and pressure of the gas supplied to the installation (► [Installation manual](#)).
- ✓ You will have the tools and measuring instruments you need for the connection (monitoring of carbon dioxide CO₂ and carbon monoxide CO), water column manometer, gas leak detector, etc...
- » Connect the appliance tightly to the gas supply system (follow the standards in force) (► [Installation manual](#)).
- » Remove the left-hand side panel of the oven (► [Access to components](#)).
- » Check in the table above whether it is necessary to add or remove the gas injector depending on the new gas.
- » Depending on the new gas, remove or insert the injector if necessary (► [Chart of gas injectors](#)) at the **inlet of the convection heating burner venturi and the steam burner venturi** (steam generator) (► [Gas diagram](#))
- » Check for leaks (► [Installation manual](#)):
 - Use leak detectors or spray to check the gas pipes and make sure there are no leaks.
 - Check the pressure on the gas valve on the supply side:
 - Unscrew the pressure screw by 2 to 3 turns and open the gas valve.
 - Connect the water column hose to the pressure tap and close the gas valve.
 - Monitor the water column level for 1 minute. An unchanged reading at -1 mbar is expected.
 - Check the static pressure (appliance not in operation):
 - Check the pressure using a water column.
 - The reading must be the same as or higher than the pressure specified on the nameplate.
- » Check the connection pressure/dynamic pressure (► [Installation manual](#)):
 - Connect a water column pressure gauge to the pressure tap when the burner is in operation (all gas appliances in operation, burners on).
 - The gas pressure measured in this way must be within the pressure range indicated on the nameplate for the gas used (► [Installation manual](#)).
- » Set the measuring instrument to "CO₂" for a calculation result of "CO₂ rate in %".
- » From the "Home" menu screen, select the "Settings" button.
 - ☒ The screen displays the "Parameters" menu with the "User" tab selected.
- » Select the "Service" tab.
 - ☒ The PIN code identification pop-up appears.
- » Enter the PIN code (level 7) to access the "Service" parameters (► [Settings](#) - PIN Codes).
- » Confirm by pressing the "✓" icon. If the code is correct, access to the screen is authorised; if not, return to entering the PIN code.
 - ☒ The screen displays the "Parameters" menu with the "Service" tab displayed.
- » Press the "CO₂ control & adjustment" button.
- » Confirm by pressing the « ✓ » icon.
 - ☒ The "CO₂ control" screen appears.
- » Set up the oven with the new gas.
 - Press the gas type field.
 - ☒ The pop-up with the list of gases appears.
 - Select the desired gas type (Gas A = GA, Gas E = GE)
 - ☒ The gas type is changed in the field.
- » Start the test by pressing the "Start" button (► [Combustion gas analysis procedure](#)).
- » When the display shows "Full control / adjustment achieved", press "End" to return to the previous screen.
- » On the new gas plate, fill in the gas corresponding to the gas for which the appliance has been set.

Convection		Steam	
Max :			Btu/h
Min :			Btu/h
Gas			
Type	Gas Natural	Propane	
P (in.WC)			

- » Stick the new gas plate in place.

14.4 CHANGING/ADJUSTING GAS VALVE

When replacing a gas valve, it is imperative to carry out a leak check and adjust the gas valve by performing a flue gas analysis.

Checking for leaks (► [Installation manual](#))

- » Use leak detectors or spray to check the gas pipes and make sure there are no leaks.
- » Check the pressure on the gas valve on the supply side:
 - Unscrew the pressure screw by 2 to 3 turns and open the gas valve.
 - Connect the water column hose to the pressure tap and close the gas valve.
 - Monitor the water column level for 1 minute. An unchanged reading at -1 mbar is expected.
- » Check the static pressure (appliance not in operation):
 - Check the pressure using a water column.
 - The reading must be the same as or higher than the pressure specified on the nameplate.
- » Check the connection pressure/dynamic pressure:
 - Connect a water column pressure gauge to the pressure tap when the burner is in operation (all gas appliances in operation, burners on).
 - The gas pressure measured in this way must be within the pressure range indicated on the nameplate for the gas used (► [Installation manual](#)).

Valve adjustment

MANDATORY carry out a burnt gas analysis and adjust the RQ and CO₂ screws of the gas valve if necessary, for a CO<150ppm (► [Combustion gas analysis procedure](#)).

The evacuation of combustion gases must comply with local legislation.

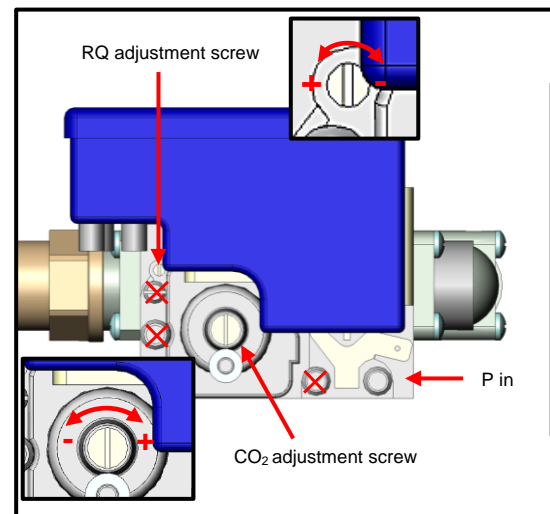
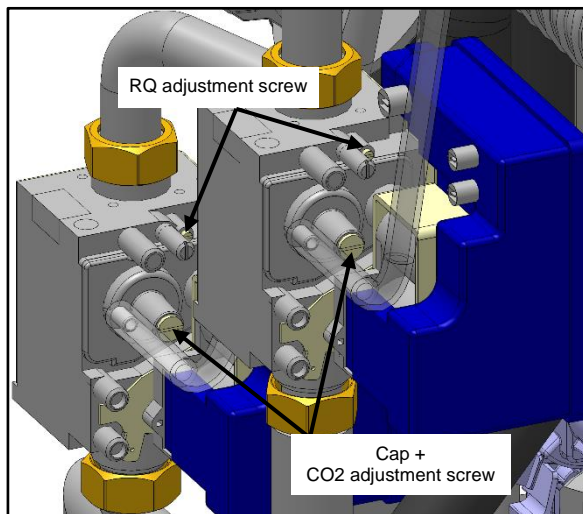

15. CONVERSION TABLES

15.1 PT100 PROBE

PT100 probe components

Temperature probe comprises a resistance probe with the value of 100 ohms for a temperature of 0° and 138.5 ohms for a temperature of 100°C. The variation of the resistance to temperature relationship is linear. The resistance reading is directly proportional to the measured temperature. The probe is not polarised. The probe can be extended using copper wire.

Temperature in °F relative to Resistance in Ω for PT100 probe										
°F	0	1	2	3	4	5	6	7	8	9
30			100.00	100.22	100.43	100.65	100.87	101.09	101.30	101.52
40	101.74	101.95	102.17	102.39	102.60	102.82	103.04	103.25	103.47	103.69
50	103.90	104.12	104.34	104.55	104.77	104.98	105.20	105.42	105.63	105.85
60	106.07	106.28	106.50	106.71	106.93	107.15	107.36	107.58	107.79	108.01
70	108.23	108.44	108.66	108.87	109.09	109.30	109.52	109.73	109.95	110.17
80	110.38	110.60	110.81	111.03	111.24	111.46	111.67	111.89	112.10	112.32
90	112.53	112.75	112.96	113.18	113.39	113.61	113.82	114.04	114.25	114.47
100	114.68	114.90	115.11	115.33	115.54	115.76	115.97	116.18	116.40	116.61
110	116.83	117.04	117.26	117.47	117.68	117.90	118.11	118.33	118.54	118.76
120	118.97	119.18	119.40	119.61	119.82	120.04	120.25	120.47	120.68	120.89
130	121.11	121.32	121.53	121.75	121.96	122.18	122.39	122.60	122.82	123.03
140	123.24	123.46	123.67	123.88	124.09	124.31	124.52	124.73	124.95	125.16
150	125.37	125.59	125.80	126.01	126.22	126.44	126.65	126.86	127.08	127.29
160	127.50	127.71	127.93	128.14	128.35	128.56	128.78	128.99	129.20	129.41
170	129.62	129.84	130.05	130.26	130.47	130.68	130.90	131.11	131.32	131.53
180	131.74	131.96	132.17	132.38	132.59	132.80	133.01	133.23	133.44	133.65
190	133.86	134.07	134.28	134.50	134.71	134.92	135.13	135.34	135.55	135.76
200	135.97	136.19	136.40	136.61	136.82	137.03	137.24	137.45	137.66	137.87
210	138.08	138.29	138.51	138.72	138.93	139.14	139.35	139.56	139.77	139.98
220	140.19	140.40	140.61	140.82	141.03	141.24	141.45	141.66	141.87	142.08
230	142.29	142.50	142.71	142.92	143.13	143.34	143.55	143.76	143.97	144.18
240	144.39	144.60	144.81	145.02	145.23	145.44	145.65	145.86	146.07	146.28
250	146.49	146.70	146.91	147.11	147.32	147.53	147.74	147.95	148.16	148.37
260	148.58	148.79	149.00	149.21	149.41	149.62	149.83	150.04	150.25	150.46
270	150.67	150.88	151.08	151.29	151.50	151.71	151.92	152.13	152.33	152.54
280	152.75	152.96	153.17	153.38	153.58	153.79	154.00	154.21	154.42	154.62
290	154.83	155.04	155.25	155.46	155.66	155.87	156.08	156.29	156.49	156.70
300	156.91	157.12	157.33	157.53	157.74	157.95	158.15	158.36	158.57	158.78
310	158.98	159.19	159.40	159.61	159.81	160.02	160.23	160.43	160.64	160.85
320	161.05	161.26	161.47	161.67	161.88	162.09	162.29	162.50	162.71	162.91
330	163.12	163.33	163.53	163.74	163.95	164.15	164.36	164.57	164.77	164.98
340	165.18	165.39	165.60	165.80	166.01	166.21	166.42	166.63	166.83	167.04
350	167.24	167.45	167.66	167.86	168.07	168.27	168.48	168.68	168.89	169.09
360	169.30	169.51	169.71	169.92	170.12	170.33	170.53	170.74	170.94	171.15
370	171.35	171.56	171.76	171.97	172.17	172.38	172.58	172.79	172.99	173.20
380	173.40	173.61	173.81	174.02	174.22	174.43	174.63	174.83	175.04	175.24
390	175.45	175.65	175.86	176.06	176.26	176.47	176.67	176.88	177.08	177.29
400	177.49	177.69	177.90	178.10	178.30	178.51	178.71	178.92	179.12	179.32
410	179.53	179.73	179.93	180.14	180.34	180.55	180.75	180.95	181.16	181.36
420	181.56	181.77	181.97	182.17	182.38	182.58	182.78	182.98	183.19	183.39
430	183.59	183.80	184.00	184.20	184.40	184.61	184.81	185.01	185.22	185.42
440	185.62	185.82	186.03	186.23	186.43	186.63	186.84	187.04	187.24	187.44
450	187.65	187.85	188.05	188.25	188.45	188.66	188.86	189.06	189.26	189.46
460	189.67	189.87	190.07	190.27	190.47	190.67	190.88	191.08	191.28	191.48
470	191.68	191.88	192.09	192.29	192.49	192.69	192.89	193.09	193.29	193.49
480	193.70	193.90	194.10	194.30	194.50	194.70	194.90	195.10	195.30	195.50
490	195.71	195.91	196.11	196.31	196.51	196.71	196.91	197.11	197.31	197.51
500	197.71	197.91	198.11	198.31	198.51	198.71	198.91	199.11	199.31	199.51
510	199.71	199.91	200.11	200.31	200.51	200.71	200.91	201.11	201.31	201.51
520	201.71	201.91	202.11	202.31	202.51	202.71	202.91	203.11	203.31	203.51
530	203.71	203.91	204.11	204.31	204.51	204.71	204.90	205.10	205.30	205.50
540	205.70	205.90	206.10	206.30	206.50	206.70	206.89	207.09	207.29	207.49
550	207.69	207.89	208.09	208.29	208.48	208.68	208.88	209.08	209.28	209.48
560	209.67	209.87	210.07	210.27	210.47	210.67	210.86	211.06	211.26	211.46
570	211.66	211.85	-	-	-	-	-	-	-	-

How to read the chart:

- To find the resistance corresponding to a temperature of 364°F.
- Find the intersection of the line 360°F and the column 4°F.
- The reading shows 169.92 Ohms.

Check

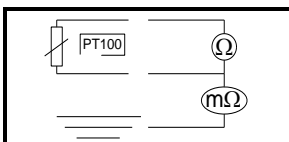

- Check probe resistance with an ohmmeter set to 200 ohms (less than 107 ohms for 68°F).
- Check the probe insulation between one of the leads and the metal part with the ohmmeter set at 20 mega ohms (a value over 15 mega ohms).
- Check the continuity between the feed and the metal part of the probe.



15.2 CELSIUS / FAHRENHEIT TEMPERATURE

Value in °C	Value in °F	Specific temperatures
23°C	73°F	Maximum cold water inlet temperature (city or softened)
25°C	77°F	Minimum temperature in Convection mode and Mixed mode
30°C	86°F	Minimum temperature in Steam mode
35°C	95°F	
40°C	104°F	
45°C	113°F	
50°C	122°F	
55°C	131°F	
60°C	140°F	Maximum operating temperature for cleaning products
65°C	149°F	
70°C	158°F	
75°C	167°F	Maximum electronic temperature
80°C	176°F	
85°C	185°F	
90°C	194°F	
95°C	203°F	
100°C	212°F	
10°C	230°F	

Value in °C	Value in °F	Specific temperatures
120°C	248°F	
130°C	266°F	Maximum temperature in steam mode
140°C	284°F	
150°C	302°F	
160°C	320°F	
170°C	338°F	
180°C	356°F	No-Fail mode operating temperature
190°C	374°F	
200°C	392°F	
210°C	410°F	
220°C	428°F	
230°C	446°F	
240°C	464°F	
250°C	482°F	
260°C	500°F	
270°C	518°F	
280°C	536°F	
290°C	554°F	
300°C	572°F	Maximum temperature in Convection mode and Mixed mode
400°C	752°F	Safety temperature

15.3 WATER HARDNESS

	°dH	°f	°e	ppm	mmol/l	gr/gal	mval/kg	CaO [mg/l]	CaCO ₃ [mg/l]	Ca ²⁺ [mg/l]
1 °f (France)	0.56	1	0.70	10,0	0.1	0.584	0.2	5.60	10.0	4.00
1 °e (GB)	0.8	1.43	1	14.25	0.14	0.83	0.284	7.98	14.25	5.71
1 °dH (Germany)	1	1.78	1.25	17.9	0.1783	1.042	0.357	10	17.85	7.15
1 ppm (USA)	0,056	0.1	0.07	1	0.01	0.0584	0.02	0.56	1.0	0.40
1 gr/gal (USA)	0.96	1.71	1.20	17.1	0.171	1	0.342	9.60	17.11	6.85
1 mmol/l	5.60	10.01	7.02	100.1	1	5.84	2	56.07	100.1	40.08
1 mval/kg	2.8	5.0	3.51	50	0.5	2.92	1	28.04	50.0	20.04

15.4 PRESSURE

kPa	bar	mbar	psi	Inch / wc
0,1	0,001	1	0,0145	0,4019
0,2	0,002	2	0,0290	0,8037
0,3	0,003	3	0,0435	1,2056
0,4	0,004	4	0,0580	1,6075
0,5	0,005	5	0,0725	2,0093
0,6	0,006	6	0,0870	2,4112
0,7	0,007	7	0,1015	2,8131
0,8	0,008	8	0,1160	3,2149
0,9	0,009	9	0,1305	3,6168
1	0,01	10	0,1450	4,0187
2	0,02	20	0,2901	8,0373
3	0,03	30	0,4351	12,0560
4	0,04	40	0,5802	16,0746
5	0,05	50	0,7252	20,0933
6	0,06	60	0,8702	24,1119
7	0,07	70	1,0153	28,1306
8	0,08	80	1,1603	32,1492
9	0,09	90	1,3053	36,1679
10	0,1	100	1,4504	40,1865
20	0,2	200	2,9008	80,3730
30	0,3	300	4,3511	120,5595

kPa	bar	mbar	psi	Inch / wc
40	0,4	400	5,8015	160,7460
50	0,5	500	7,2519	200,9325
60	0,6	600	8,7023	241,1190
70	0,7	700	10,1527	281,3055
80	0,8	800	11,6030	321,4920
90	0,9	900	13,0534	361,6785
100	1	1000	14,5038	401,8650
150	1,5	1500	21,7557	602,7975
200	2	2000	29,0076	803,7300
250	2,5	2500	36,2595	1004,6625
300	3	3000	43,5114	1205,5950
350	3,5	3500	50,7633	1406,5275
400	4	4000	58,0152	1607,4600
450	4,5	4500	65,2671	1808,3925
500	5	5000	72,5190	2009,3250
550	5,5	5500	79,7709	2210,2575
600	6	6000	87,0228	2411,1900
700	7	7000	101,5266	2813,0550
800	8	8000	116,0304	3214,9200
900	9	9000	130,5342	3616,7850
1000	10	10000	145,0380	4018,6500