



655 Eisenhower Drive
 Owatonna, MN 55060 USA
 Phone: (507) 455-7000
 Tech. Serv.: (800) 533-6127
 Fax: (800) 955-8329
 Order Entry: (800) 533-6127
 Fax: (800) 283-8665
 International Sales: (507) 455-7223
 Fax: (507) 455-7063

Form No. 579899

**Parts List &
 Operating Instructions for:**

**4847
 4847A**

Twin Cam Inner Cam Bearing Remover Kit



Item No.	Qty.	Description
1	4	Thumb Screw
2	1	Plate Installer, Cam Bearing
3	1	Dowel Pin
4	1	Forcing Screw
5	2	Inner Cam Bearing Puller
6	2	Remover Body

Item No.	Qty.	Description
7	1	Brass Washer, 3/4-in.
8	1	Nut, Hex
9	2	Installer Tool, Cam Bearing
10	1	O- Ring
11	1	Driver Tool, Cam Bearing

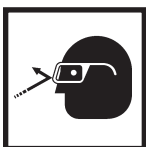

WARNING: Wear eye protection that meets ANSI Z87.1 and OSHA standards.

Sheet No. 1 of 2

Issue Date: Rev. A, April 19, 2017



Cam Bearing Removal Instructions

CAUTION: The cam bearing remover kit includes two inner cam bearing pullers. The smaller diameter bearing puller is used for cam bearings on early models. The larger diameter puller is used for cam bearings on late twin cams. Select the proper size bearing puller for your particular-size bearing. There is also an associated remover body for each bearing puller. The smaller diameter remover body is used with the smaller bearing puller. The larger diameter remover body is used with the larger bearing puller.

1. Push the inner cam bearing puller (item 4) through the cam bearing (grooved end first). You can tap the end of bearing puller with a soft, dead-blow hammer until the puller is completely through the cam bearing. See Figure 1.
2. Slide the remover body (5) over the end of the bearing puller (4). Ensure the bore of the remover body is facing the cam bearing.
3. Apply a small amount of lubricating oil to the face of the washer and the threads on the nut. Then slide the washer over the end of the puller and thread the nut onto the end of the puller.
4. Tighten the nut (1) until the washer (2) is snug against the remover body (5).
5. Apply a small amount of lubricating oil to the dowel pin (3) and insert the dowel pin through the center of the bearing puller (4) until its flush with the top of the puller.
6. With a 1½-in. wrench, turn the nut clockwise until the bearing pulls free from the case. To prevent the puller from turning, hold the bearing puller with a 5⁄8-in. wrench. **CAUTION:** Do not turn the bearing puller with the 5⁄8-in. wrench. Damage to the tool could result.

Item		
No.	Qty.	Description
1	1	Nut, Hex
2	1	Brass Washer, 3⁄4-in.
3	1	Dowel Pin
4	2	Inner Cam Bearing Puller
5	2	Remover Body

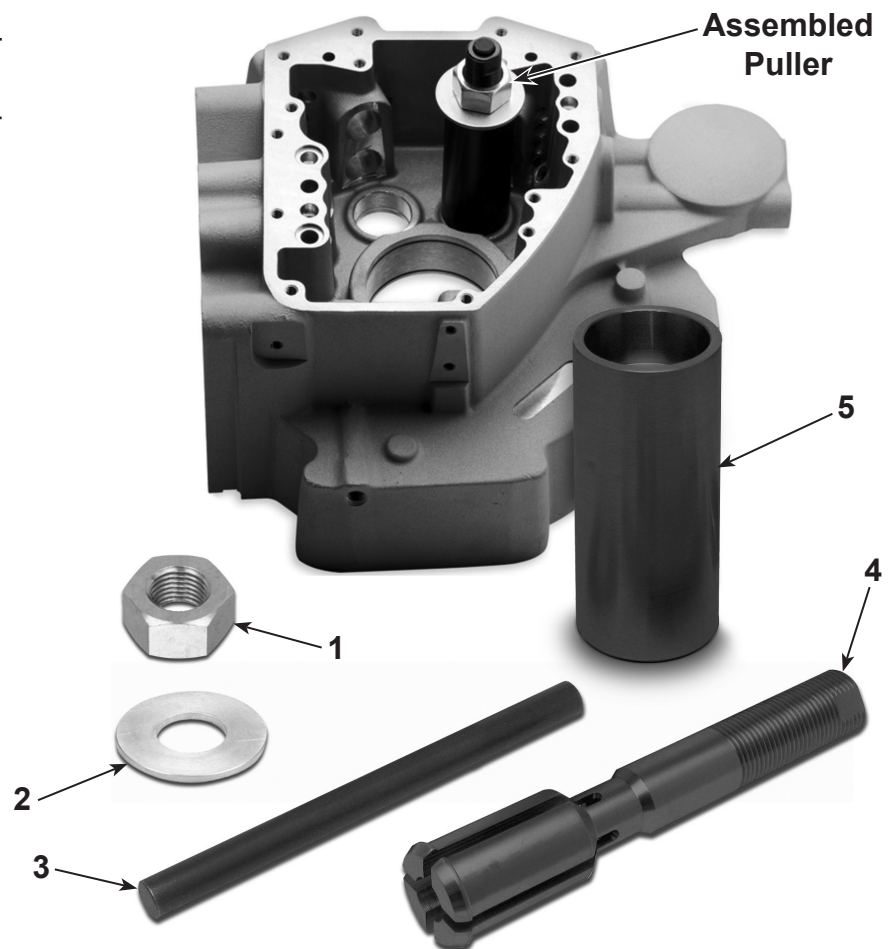

Figure 1

Cam Bearing Installation Instructions

1. Apply a small amount of lubricating oil to the threads of the forcing screw (item 2). Then thread the forcing screw into the cam bearing installer plate (6). See Figure 2.
 2. Thread the cam bearing driver tool (3) onto the end of the forcing screw (2).
- CAUTION:** On the cam bearing installer tool (1), notice that one end of the tool has a larger step than the other end. The small step is used for cam bearings on early models. The large step is used for cam bearings on late twin cams. Select the proper end of the installer tool for your particular-size bearing.
3. Select the proper end of the cam bearing installer tool (1) for your particular cam bearing, then push the other end of the installer tool onto the end of the cam bearing driver tool (3). Make sure the O-ring (4) on the end of the driver tool is in place when attaching the installer tool.
 4. Before installing a new cam bearing, pay attention to the letters and numbers marked on the bearing. The bearing must be oriented with the letters and numbers facing outward (up) against the cam bearing installer tool (1).
 5. Apply bearing assembly lubrication on the outside diameter of the cam bearing.
 6. Align the two large holes in the installer plate over the bearing bores.
 7. Attach the assembled tool (with bearing in position) to the cam housing case, using four lubricated thumb screws (5). **CAUTION:** Lubricate the threads on each thumb screw before threading them into place.
 8. Ensure the threads on the forcing screw (2) are well lubricated. Then carefully and slowly, turn the forcing screw clockwise. Once the bearing safely clears the bore, continue to tighten the forcing screw until the bearing is fully seated in the bore. Repeat the process for the next bearing.
 9. After the new bearings are pressed in place, remove the plate from cam housing case.

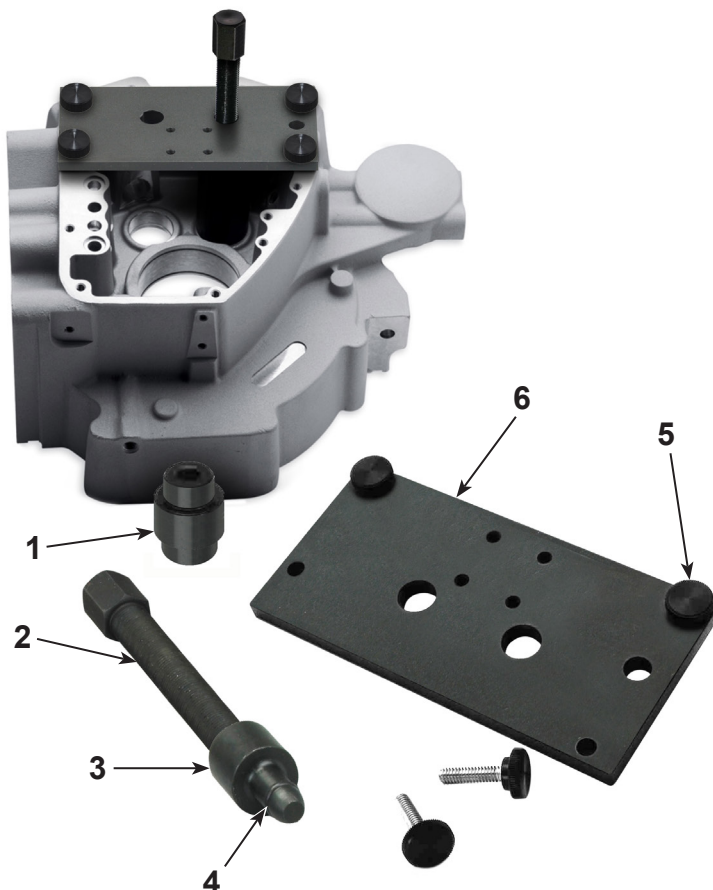

Figure 2

Item		
No.	Qty.	Description
1	2	Installer Tool, Cam Bearing
2	1	Forcing Screw
3	1	Driver Tool, Cam Bearing
4	1	O- Ring
5	4	Thumb Screw
6	1	Installer Plate, Cam Bearing