

# Honeywell

## **EN** Portable Air Conditioner User Manual

Read and save these instructions before use

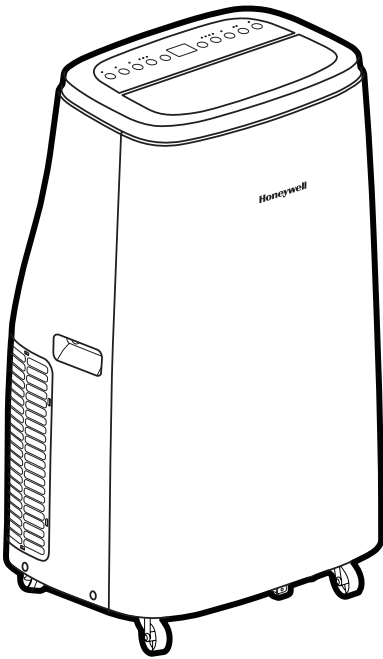

---

Model:  
HJ0CESWK7/  
HJ2CESWK8/  
HJ4CESWK9/  
HJ5CESWK0

---

Customer Support:  
Web: [www.jmatek.com](http://www.jmatek.com)  
USA: 1-800-474-2147 | [usinfo@jmatek.com](mailto:usinfo@jmatek.com)  
CANADA^: [canadainfo@jmatek.com](mailto:canadainfo@jmatek.com)

^ Canada Customer Support service available for models sold in Canada only.



## READ AND SAVE THESE INSTRUCTIONS

IMPORTANT SAFETY INSTRUCTIONS. READ CAREFULLY AND KEEP FOR FUTURE REFERENCE. IN CASE THERE IS ANY INCONSISTENCY OR CONFLICT BETWEEN THE ENGLISH VERSION AND ANY OTHER LANGUAGE VERSION OF THE CONTENT OF THIS MATERIAL, THE ENGLISH VERSION SHALL PREVAIL.

### WARNING:

- Basic safety precautions should always be followed when using electrical appliances.
- Electrical equipment and installations regulated by national legislation must be followed.
- The appliance should be transported upright or on its side.
- Do not turn on the appliance for at least one hour before starting it.
- DO NOT operate the unit with a damaged plug or loose wall outlet. If the supply cord is damaged, it must be replaced by the manufacturer, its service agent or similarly qualified persons in order to avoid a hazard.
- DO NOT cover the air intake and exhaust when in use.
- DO NOT place objects, especially heavy or hot objects, on top of unit. DO NOT sit on the unit.
- Always turn off and unplug the unit when cleaning or servicing.
- DO NOT use the appliance if it is damaged.
- Do not modify this appliance in any way to avoid danger.
- If service is needed contact an authorized service agent. Repairs must only be undertaken by authorized service centres of the manufacturer. Failure to comply may be dangerous.
- Unplug the unit when stored or not in use.
- DO NOT pull or carry the appliance by the power cord.
- DO NOT pinch the power cord in the door and DO NOT pull it along edges or sharp corners.

## SAFETY (CONTINUED)

- Do not pierce or burn the unit.
- It is essential that the appliance is connected to an efficient earth system checked by a qualified electrician.
- Refrigerant gas may be odorless.
- Stagnation of possible leaks of refrigerant gas in unventilated rooms could lead to fire or an explosion hazard should the refrigerant come in contact with electric heaters, stoves or other sources of ignition.
- Use care when storing the appliance to prevent mechanical faults.
- Only persons authorized by an accredited agency certifying their competence to handle refrigerants in compliance with sector legislation should work on refrigerant circuits.
- Maintenance and repairs requiring the assistance of other qualified personnel must be carried out under the supervision of specialists in the use of inflammable refrigerants.
- DO NOT use means to accelerate the defrosting process or to clean, other than those recommended by the manufacturer.
- DO NOT run the power cord under carpeting and rugs. Use caution to prevent tripping on cord.
- DO NOT use the device in the following cases:
  - in a room with continuously operating sources of ignition (eg. open flames, an operating gas appliance or an operating electrical heaters).
  - In areas where gasoline, sulphur, oil, paint or other flammable goods are stored.
  - In an area where the water can be projected.
- DO NOT touch the plug or the device with wet hands.
- Flammable substances or pressurized containers (eg. aerosol cans) should be kept a minimum of 50cms away.
- This appliance has been manufactured for use in domestic environments and should not be used for other purposes.

## SAFETY (CONTINUED)

- Use only implements recommended by the manufacturer for defrosting or cleaning.
- **Only use the installation kit provided to install this unit. DO NOT attempt to extend the hose or install this unit using other methods other than that shown in this manual. Improper installation will void any existing warranties.**
- DO NOT use an extension cord with this unit.
- This appliance can be used by children aged from 8 years and above, and persons with reduced physical, sensory or mental capabilities or lack of experience and knowledge if they have been given supervision or instruction concerning use of the appliance in a safe way and understand the hazards involved. Children shall not play with the appliance. Cleaning and user maintenance shall not be made by children without supervision.
- Never insert your fingers or rods into the air outlet. Take special care to warn children of these dangers.
- The manufacturer is not liable for injury caused to persons or property damage due to non-compliance with maintenance instructions and improper use of the appliance.
- The appliance shall be installed in accordance with national wiring regulations.
- The appliance is not to be used by persons (including children) with reduced physical, sensory or mental capabilities, or lack of experience and knowledge, unless they have been given supervision or instruction.
- DO NOT operate your air conditioner in a wet room such as a bathroom or laundry room.
- This appliance should be used in a room that allows for good ventilation between the unit and any walls/furniture or other objects. The room size should correspond to the room area as specified for operation by the manufacturer and the appliance should be well kept to prevent mechanical damage.

## SAFETY (CONTINUED)

- A warning to keep ventilation openings clear of obstruction.
- Do not pierce or burn the refrigerants.
- Be aware that refrigerants may not contain an odor.

# THANK YOU

Congratulations on your purchase of this Honeywell Portable Air Conditioner.

Regarding the information pertaining to the installation, handling, servicing, cleaning and disposal of the appliance, please refer to the below paragraph of the manual.

## USER TIPS

Portable Air Conditioners are ideal for spot cooling. The compressor, condenser and evaporator are housed in a compact unit. The air is dehumidified and cooled while a flexible hose sends heat outside. The Portable Air Conditioner includes a window venting kit.

No permanent installation is needed. The unit is easy to move from room to room and offers a truly flexible air conditioning solution.

Auto Evaporation System - The unit automatically evaporates the condensate through the hose. There is no need to empty the drainage tank except in humid conditions. Read and follow the instructions carefully.

To ensure optimal efficiency of the product, keep doors and windows closed when it is used as an air conditioner or dehumidifier. If the product is being used with the fan function only, an open window could improve air circulation.

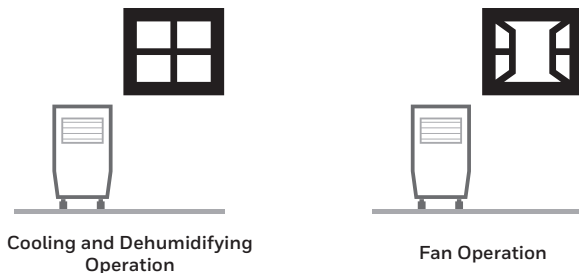

### Important:

Before installing the unit, place it UPRIGHT for 1 hour before use to allow the refrigerant to stabilize. Air outlet automatically opens when the unit is turned on, and automatically closes when the unit is turned off. Manually adjust the air vent located at the top of the unit to adjust the direction of air flow.

- Follow installation instructions to set up the unit.
- Plug the unit into a properly grounded circuit. DO NOT plug into an extension cord.

# PARTS DESCRIPTION

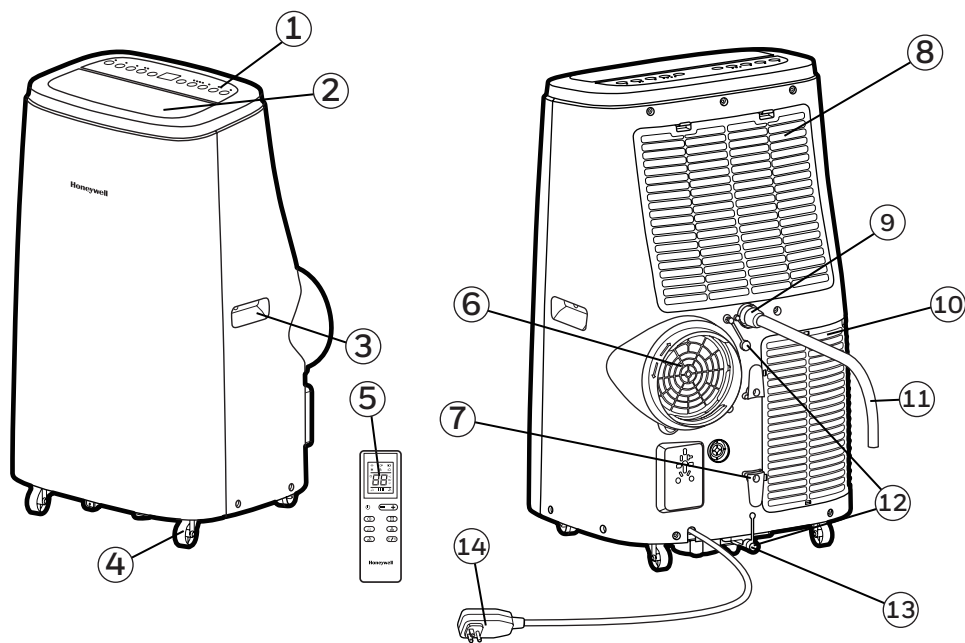

1) Control Panel

2) Air Outlet

3) Handle

4) Casters

5) Remote Control

6) Hose Connector

7) Cord Winder

8) Upper Dust Filter

9) Upper Rubber Drain Plug  
(Dehumidifying Mode)

10) Lower Dust Filter

11) Drain Tube  
(For Continuous Drain)

12) Drain Plug Cap

13) Lower Rubber Drain Plug  
(Air Conditioning Mode)

14) Power Supply Cord

# INSTALLATION

It is important that the installation instructions below are followed for successful installation of this Portable Air Conditioner. Please call Customer Support if you have any difficulties or queries regarding these installation procedures.

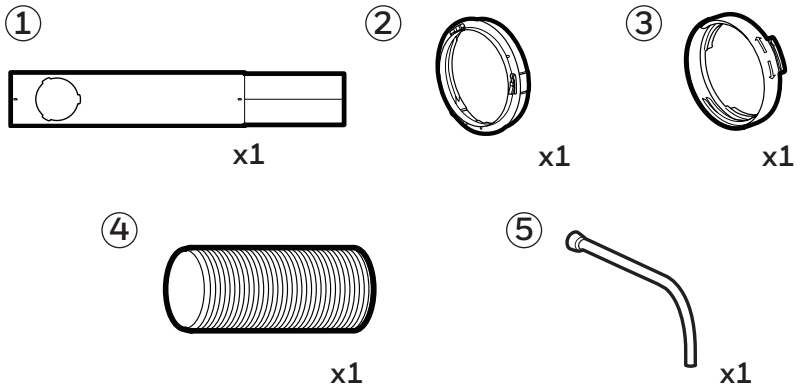

## Installation Kit:

- |                                 |           |                 |           |
|---------------------------------|-----------|-----------------|-----------|
| 1. Window Bracket Kit           | (1 Set)   | 4. Exhaust Hose | (1 Piece) |
| 2. Window Bracket Panel Adapter | (1 Piece) | 5. Drain Tube   | (1 Piece) |
| 3. Exhaust Hose Connector       |           |                 |           |

## Installation Steps:

1. Exhaust Hose Connector, Exhaust Hose and window bracket panel adapter are pre-assembled inside the package.

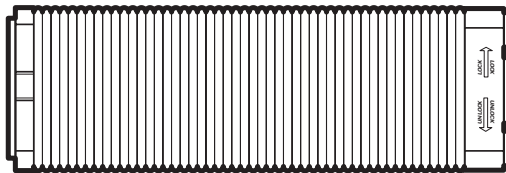

Hose:  
Length: 10.23" to 47" (26cm to 120cm)

# INSTALLATION (CONTINUED)

## Window Bracket Kit:



Part A:  
Min. Length 19.7" (50 cm)

+

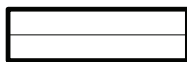

Part B

=



Part A + B:  
Min. Length 19.7" (50 cm)  
Max. Length 38.2" (97 cm)

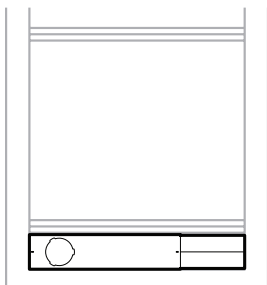

Horizontal Sliding Window

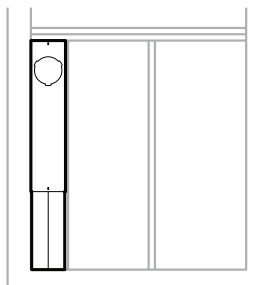

Vertical Sliding Window

This window kit is designed to fit most standard sliding windows. If your window is outside of the size parameters as outlined above, the window bracket can be cut shorter to fit by bringing it to a nearby hardware store.

**Note:** After setting the window bracket to the size of your window, please remove it from the window and follow the instructions below.

2. Connect the hose to the rear exhaust outlet on the back of the unit. Slide-in the hose connector then rotate clockwise until it is locked in place.

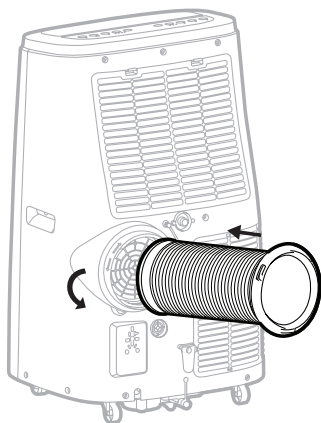

Hose:  
Dia.5.9" (15cm)  
Length: 10.23" to 47" (26cm to 120cm)

# INSTALLATION (CONTINUED)

3. Connect the window bracket to the window bracket panel adapter. Ensure that all connections are tight and installed properly.

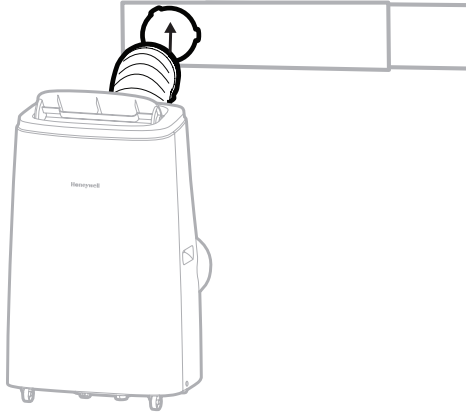

4. Connect the window bracket to the window.

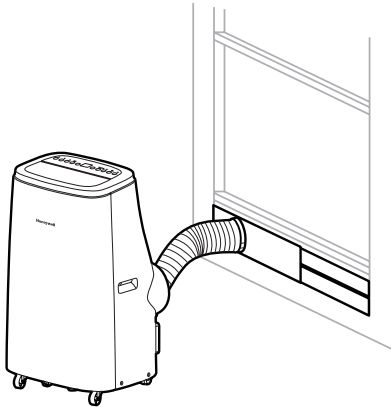

Horizontal Sliding Window

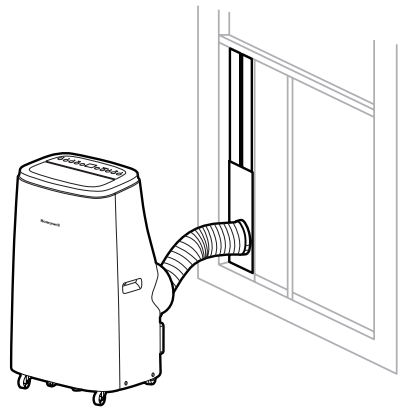

Vertical Sliding Window

5. The Portable Air Conditioner is now ready to use.

# INSTALLATION (CONTINUED)

## IMPORTANT:

Do not replace or lengthen the hose as this could cause the unit to malfunction.

The length of the hose is scientifically determined by the specifications and airflow of the air conditioner. Extending the hose beyond the specified dimensions can cause heat to collect or flow back into the air conditioner causing the unit to malfunction.

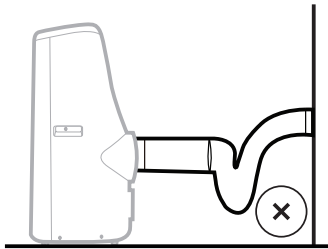

Not Recommended

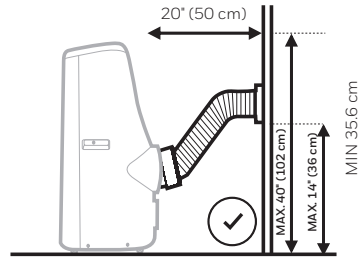

Recommended

**WARNING:** Any warranties included with this product will be voided if an extra extension hose is added to the originally provided installation kit or if the installation is performed differently than the manufacturer's instructions, without proper consultation. Please contact Customer Support for help with installation procedures if needed.

- The supplied hose has a diameter of 5.9" (15 cm) and can be extended from 10.23" to 47" (26cm to 120cm).
- Do not bend (to the extent shown above) the hose. A bent hose will block exhaust air and cause the unit to malfunction or shut-off.
- Make sure the back of the unit is at least 20" (50 cm) away from the wall. Do not place the unit in front of curtains or drapes as this could obstruct the airflow.

## CONTROL PANEL

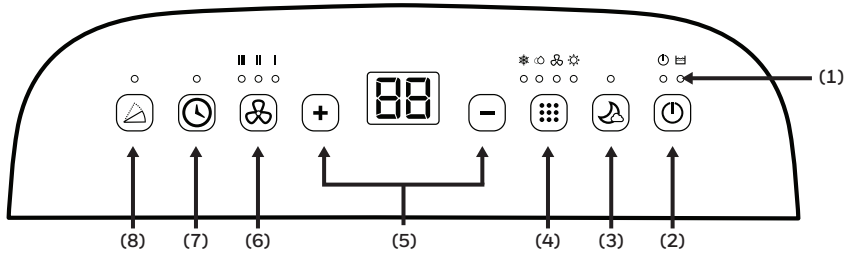

- |                     |                                     |
|---------------------|-------------------------------------|
| 1) Indicator Lights | 5) Timer / Temperature Set Controls |
| 2) Power Control    | 6) Fan Speed Control                |
| 3) Sleep Mode       | 7) Timer Control                    |
| 4) Mode Control     | 8) Swing Control                    |

## FUNCTION BUTTONS

### POWER CONTROL

Press  to turn ON/OFF the unit. The air vent will automatically swing open when the unit is turned ON and automatically close when the unit is turned OFF.

### RESTART DELAY

If the unit turns OFF while operating in COOL mode, there will be an approx. 3-minute delay to restart the air conditioner in COOL mode. This is a safety feature and added to help protect and extend the life of the compressor. After 3 minutes, you will be able to turn ON the unit as usual.

### FAN SPEED CONTROL

3 settings: High, Medium, and Low.



**Note:** Fan Speed cannot be adjusted in Sleep Mode and Dehumidifying Mode.

## FUNCTION BUTTONS (CONTINUED)

### MODE CONTROL



Settings: Air Conditioning, Dehumidifying, Fan, Heating\*.

The corresponding indicator light will illuminate to indicate the current mode setting.

- Air Conditioning Mode (COOL)   
Adjust fan speed and air temperature to suit your desired comfort level.  
Temperature setting range is 60°F - 90°F (16°C - 32°C).
- Dehumidifying Mode (DRY)   
Air is dehumidified as it passes through the unit, without being in full cooling mode.  
The fan speed is preset as LOW speed and can NOT be adjusted.

**Note:** If the unit will be used mainly as a dehumidifier, do not connect the exhaust hose. Continuous drainage is then necessary (refer to Continuous Draining for Dehumidifier Mode).

**IMPORTANT:** The Dehumidifier Mode is used to support moisture reduction but should not be expected to dehumidify to the same degree as a standard dehumidifier only appliance. The built-in dehumidifier automatically adjusts dehumidification based on ambient room temperatures. It is not possible to adjust to a desired humidity percentage. The front display only shows the current and desired temperatures. It does not show humidity levels.

- Fan Mode   
For air circulation without air conditioner cooling.
- Heating Mode\*   
When heating mode is selected the indicator light will shine. Heating is activated only when the ambient temperature is below 77°F (25°C). In this mode, the desired temperature can be set between 61°F - 77°F (16°C - 25°C).

**Note:** The exhaust hoses must vent outside the room when using heating mode.

**IMPORTANT:** The Heat pump draws moisture from the air which then condenses into the internal water tank. The unit will pause operation when the tank is full and will restart when the tank has been emptied. It is recommended to use the Heating Mode in a room with 50% humidity or lower. Avoid operating moisture-producing products or appliances such as a humidifier or a kettle when using the unit in Heating Mode. See the "Draining Water Condensation in Heat Mode" section for more information on draining the water tank.

### TIMER / TEMPERATURE SET CONTROLS

The **—** and **+** buttons can be used to adjust and set your desired temperature in Cooling or Heating\* modes. They can also be used to set the Timer (see "Timer Control" below).

**Note:** Temperature and Timer cannot be adjusted in Fan and Dehumidify modes.

\*Applicable for models with Heating feature only.

## FUNCTION BUTTONS (CONTINUED)

### SLEEP MODE

Sleep Mode is for energy-saving comfort during the night. When Sleep Mode  is ON in Air Conditioning Cooling Mode, the fan will automatically stay on LOW Speed and the set temperature will increase by 1°F (1°C) on the first hour. It will increase another 1°F (1°C) on the second hour, and remain at this temperature for the rest of the night, until Sleep Mode is deactivated.

**Note:** The control panel lights will turn OFF after 10 seconds and light up again when any button is pressed. When Sleep Mode is ON in Heating Mode\*, the fan will automatically stay on LOW Speed and the set temperature will decrease by 1°F (1°C) on the first hour. It will decrease another 1°F (1°C) on the second hour, and remain at this temperature for the rest of the night, until Sleep Mode is deactivated.

### TIMER CONTROL

While the unit is turned on, press the timer button then press the **-** or **+** to select the number of hours you would like the unit to continue to run. The unit will turn on/off automatically.

### AUTO TURN OFF:

While unit is running, press the **-** or **+** button to select the number of hours you want the unit to run in air conditioning mode.

### AUTO TURN ON:

When unit is in a standby mode (plugged in with power light on), then press the **-** or **+** button to select the number of hours until you want the unit to automatically start running.

### SWING CONTROL

Press  to activate automatic oscillation of louvers. Press again to stop swing when louvers reached a desired angle.

### WATER FULL LIGHT

Condensation may accumulate in the unit.

If the internal tank becomes full, the Water Full Light  will illuminate and unit will beep 5 times for 5 seconds. The unit will not operate until the unit has been drained (refer to Water Condensation Drainage).

## ADDITIONAL FEATURES:

### AUTOMATIC DEFROST FEATURE

Sometimes when the unit is operating in cooling mode in lower room temperatures (e.g. lower than 60°F), the internal cooling coils may become too cold and sometimes frost may develop on the cooling coils. When this happens, the unit will automatically pause operation and defrost the cooling coils to protect the unit. The air conditioner will restart automatically when the system has defrosted and returns to standard operational temperatures.

\*Applicable for models with Heating feature only.

## REMOTE CONTROL

All key functions can be accessed from the remote control.

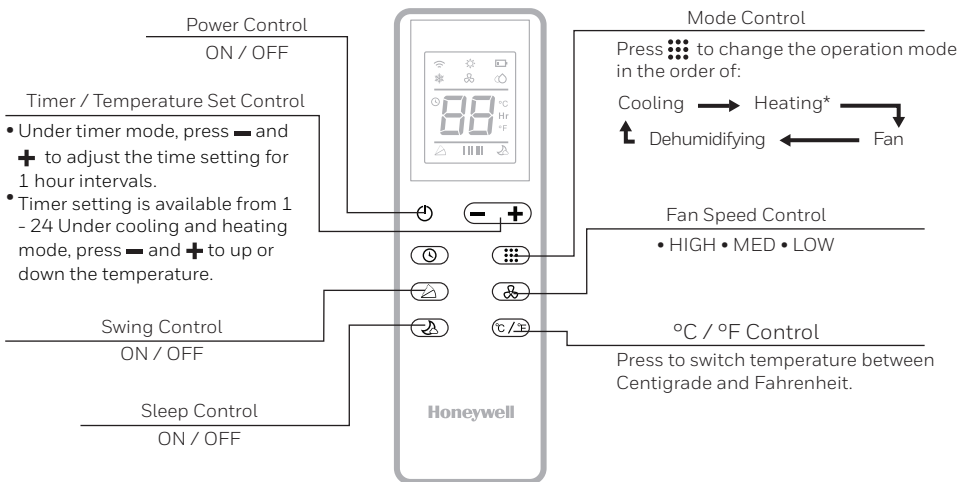

### Note:

- Battery Installation: Remove the cover on the back of the remote control and insert two AAA batteries with + and - pointing in the proper direction according to the polarity markings.

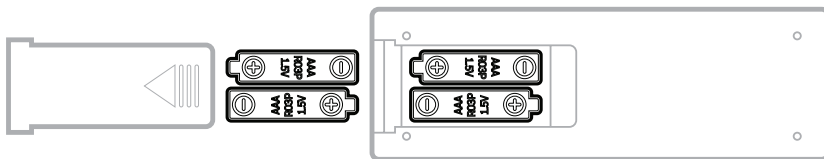

### Caution:

- Use only two AAA or IEC R03 1.5V batteries.
- Remove the batteries if the remote control is not in use for a month or longer.
- All batteries should be replaced at the same time, do not mix with old batteries.
- Do not mix alkaline, standard (carbon-zinc) or rechargeable (nickel-cadmium) batteries.
- Properly dispose of used batteries.

This device complies with part 15 of the FCC Rules. Operation is subject to following two conditions: (1) this device may not cause harmful interference, and (2) this device must accept any interference received, including interference that may cause undesired operation.

This equipment has been tested and found to comply with the limits for a Class B digital device, pursuant to part 15 of the FCC Rules. These limits are designed to provide reasonable protection against harmful interference in a residential installation. This equipment generates, uses and can radiate radio frequency energy and, if not installed and used in accordance with the instructions, may cause harmful interference to radio communications. However, there is no guarantee that interference will not occur in a particular installation. If this equipment does cause harmful interference to radio or television reception, which can be determined by turning the equipment off and on, the user is encouraged to try to correct the interference by one or more of the following measures:

- Reorient or relocate the receiving antenna.
- Increase the separation between the equipment and the receiver.
- Connect the equipment into an outlet on a circuit different from that to which the receiver is connected.
- Consult the dealer or an experienced radio/TV technician for help.

Caution: Any changes or modifications not expressly approved by the party responsible for compliance could void the user's authority to operate the equipment.

\*Applicable for models with Heating feature only.

## Appliance Maintenance:

1. Turn off the appliance before disconnecting the power supply.
2. Only clean the appliance with a soft dry cloth.

## Dust Filter Maintenance:

The dust filter is to be cleaned every two weeks to maintain air cooling efficiency. Please follow the below instructions for cleaning the dust filters:

1. Switch off and unplug the Portable Air Conditioner from the electrical outlet.
2. Remove the Upper Filter/ Grill, unscrew the Lower Filter/ Grill and carefully remove.
3. Gently wash using water and/ or diluted liquid dishwashing detergent. Rinse thoroughly and gently shake excess water from the filters. Make sure the filters are dry before reinstalling.

**Note:** You may use a vacuum cleaner to remove dust.

4. Replace the Upper Grill onto the unit, and reinstall the Lower Grill with the screw.

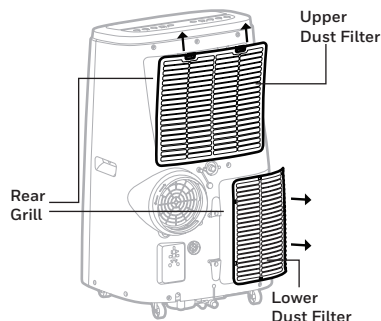

**WARNING:** DO NOT power or operate the Portable Air Conditioner when cleaning or when the Dust Filter is removed from the unit, or if there is a loose-fitting Dust Filter. DO NOT attempt to handle or touch any of the parts or wiring inside the Rear Grill after the Dust Filter has been removed from the unit. Doing so can cause serious injury or electrical shock.

## End of Season Storage and Maintenance:

If the appliance will not be used for a long time, follow these steps:

1. Be sure to drain the left-over water condensation. Remove the lower drain plug and use a drain pan to collect the water (make sure to replace the drain plug cap when finished).
2. To dry excess moisture, run the unit in Fan only mode for 30 minutes before storing.
3. Turn off and unplug the Portable Air Conditioner from the power supply.
4. Remove the dust filter and clean with water. Dry the dust filter and then reinstall.
5. Disconnecting the Window Installation Kit:
  - Remove the Hose from the unit by rotating anti-clockwise then pulling away.
  - Remove the Foam Seal, Window Bracket, Window Bracket Panel Adapter and Hose Connector.
  - It is recommended to store the Window Kit parts in a bag together with the Remote Control, Drain Tube and placing them together with the Portable Air Conditioner unit.
  - If needed, you can clean the Window Kit with a damp cloth and water before storing. Make sure all parts of the Window Kit are dry before storage.
6. Cover the Portable Air Conditioner with a cloth/ plastic bag before storage, to protect from dust and scratches collecting on the surface of the unit.
7. It is recommended to coil the power cord before storing to ensure the cord is protected from bends and creases.
8. Store the Portable Air Conditioner in a cool, dry place, away from direct sunlight.

# WATER CONDENSATION DRAINAGE

When there is excess water condensation inside the unit, the air conditioner stops running and shows a warning light (the WATER FULL indicator  illuminates with a red light). This indicates that the water condensation needs to be drained using the following procedures:

## Manual Draining in Cooling, Dehumidifying Modes

Water may need to be drained in high humidity areas.

1. Unplug the unit from power source.
2. Place a drain pan under the lower rubber drain plug.  
See diagram.
3. Remove the drain plug cap.
4. Water will drain out and collect in the shallow pan.
5. After the water is drained, replace the drain plug cap.
6. You can now turn on the unit.

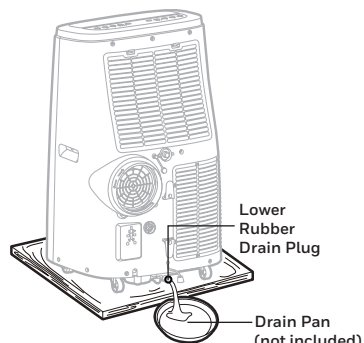

## Continuous Draining in Dehumidifier Mode

While using the unit in dehumidifier mode, continuous drainage is recommended.

1. Unplug the unit from power source.
2. Remove the upper drain plug cap.  
Some residual water may spill so please have a pan to collect the water.
3. Connect the drain tube to the upper drain plug.  
See diagram.
4. The water can be continuously drained through the drain tube into a floor drain or bucket.
5. Replace the drain plug cap.
6. You can now turn on the unit.

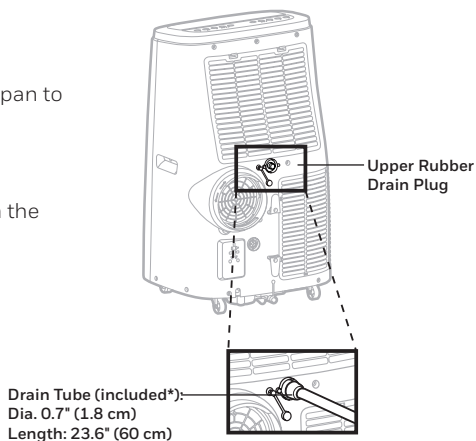

**IMPORTANT:** It is NOT recommended to connect the drain hose for continuous drainage while the unit is switched ON in air conditioning cooling mode. Doing so will reduce the cooling efficiency of the tank in more humid rooms. It is recommended to use the heating mode in a room with 50 % humidity or lower. Avoid operating moisture-creating products or appliances such as a humidifier or a kettle when using the unit in heating mode.

The water cannot be drained using the continuous drain option in heating\* mode. In Heating mode, the internal water tank collects condensation faster and may require more frequent emptying of the tank in more humid rooms. It is recommended to use the heating mode in a room with 50 % humidity or lower. Avoid operating moisture-creating products or appliances such as a humidifier or a kettle when using the unit in heating mode.

# TROUBLESHOOTING GUIDE

The following troubleshooting guide addresses the most common problems. If problems persist, call customer support. Unplug and disconnect the appliance from the power source before attempting to troubleshoot.

PROBLEM	POSSIBLE CAUSE	SOLUTION
The air conditioning unit does not start	No electricity.	Check for power.
	Batteries in the remote control need to be replaced.	Change remote control batteries.
	The power cord is not properly plugged in.	Remove and reconnect the power cord.
	The safety LCDI plug has tripped (USA / Canada / Mexico only).	Reset the safety LCDI plug, if problem persists contact our customer support (USA / Canada / Mexico only).
Runs a short while only	The thermostat temperature setting is too close to room temperature.	Lower the set temperature.
	Air outlet is blocked.	Make sure the hose is properly connected.
	There are tight bends in the air hose.	Connect hose as per instructions on page 3.

# TROUBLESHOOTING GUIDE (CONTINUED)

PROBLEM	POSSIBLE CAUSE	SOLUTION
Runs but not cooling	A door or window is open.	Make sure the window or door is closed.
	The dust filter is dirty.	Clean the dust filter.
	The hose is detached.	Reinstall hose properly (refer to Installation section).
	Temperature setting is too high.	Reduce temperature setting.
	Air outlet or intake is blocked.	Remove blockage.
	Room exceeds recommended size.	Move unit to smaller room.
	Large size or number of windows are decreasing cooling effectiveness.	Cover windows with curtains or blinds.
Will not run and WATER FULL indicator  illuminates	Excess water condensation inside the tank.	Drain the water (refer to Water Condensation Drainage).

# ERROR CODE GUIDE

ERROR CODE	ERROR POSSIBLE CAUSE
"E1"	Indoor temperature sensor failure (open circuit or short circuit).
"E2"	Pipe temperature sensor failure (open circuit or short circuit).

**JMATEK North America LLC**  
Mahwah, New Jersey 07495 USA  
Email: [usinfo@jmatek.com](mailto:usinfo@jmatek.com)  
Web: [www.jmatek.com](http://www.jmatek.com)

**EN**

Made in China  
© 2020 JMATEK Limited. All rights reserved.  
The Honeywell Trademark is used under license  
from Honeywell International Inc.  
Honeywell International Inc. makes no  
representations or warranties with respect to this product.  
This product is manufactured by Airtel Int'l Corp. Ltd.  
(subsidiary of JMATEK Ltd.).

**Honeywell**