

TOPENS[®]

DKR1100ST

Installation Manual

For sliding gate installation

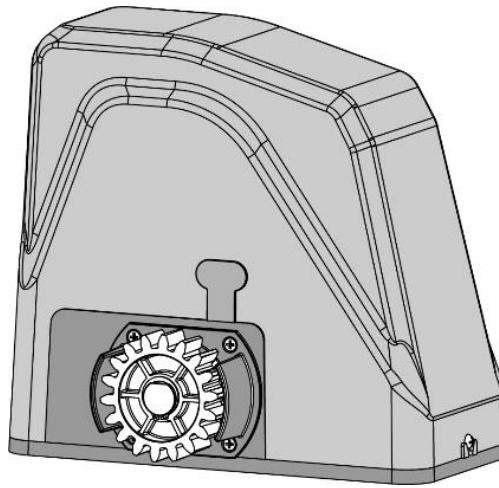

Installation Video



Equipped with 30W solar panels, this gate opener can operate independently without AC electricity. An additional 24V 12Ah Automotive / Marine type battery is required but not included. Alternatively, the opener can be powered directly by 110-120VAC electricity.

CE

CONTACT US

For Technical Support and Installation Assistance

Visit our website at www.topens.com and fill out the online form

Alternatively, you can send an email to our service team at support@topens.com

To ensure prompt and effective assistance, kindly include the following information in your email:

- **Where Did You Purchase?** _____
- **Order Information** _____
- **Your Contact Information** _____
- **Gate Information (Weight and Length)** _____
- **Did You Purchase Any Accessories? (If Yes, Please List Them)** _____
- **Issue Description (Include Any Relevant Photo or Video)** _____

For Warranty Registration

To register your warranty, please visit www.topens.com

If you have any questions regarding what is covered by the TOPENS warranty, refer to the detailed policy at www.topens.com/pages/topens-limited-warranty.

Email Us: support@topens.com

Table of Contents

Important Safety Information	1
Packing List	4
Installation Overview	5
Specifications	6
Before You Begin	7
Installation	8
Terminal Function of the Control Board	13
Connection of Power Supply	14
Setting of Left / Right Open	17
Program the Remote Control	18
Adjust the Open / Close Limit Position	19
Setting of the Control Board	21
Stall Force Adjustment & Obstruction Test	24
Connection of Accessories	25
TC188 Universal Keypad.....	25
TKP3 Wireless Keypad.....	27
TC173 Wireless Push Button.....	28
TC196 Tuya WiFi Remote Control	28
TEW3 Vehicle Sensor Exit Wand.....	29
TC175P Wired Keypad	30
HLR01 Homelink Remote Control Kit	30
JD24VY Warning Light	31
TRF3 Reflection Photocell Sensor	31
TC102 Infrared Photocell Sensor	32
ERM12 External Receiver	33
TC148 Waterproof Wall Push Button & TC147 Wall Push Button	33
Maintenance and Replacement Parts	34
Troubleshooting	35

Important Safety Information

Thank you for choosing the TOPENS DKR1100ST sliding gate opener. When installed correctly and used properly, your opener will offer years of reliable service.

This manual is designed to guide you through the proper installation of your DKR1100ST sliding gate opener. Please carefully review all instructions before commencing the installation and operation of this automatic gate opener.

Before Installation

- ◆ **GAIN UNDERSTANDING OF THE INSTALLATION PROCESS:** Please read this installation manual or view our online installation video before installing the gate opener.
- ◆ **LOCAL INSTALLATION COMPLIANCE:** Prior to installation, please verify that your planned installation complies with all relevant local building codes and ordinances. Dispose of packaging materials in accordance with local regulations.
- ◆ **SEPARATE PEDESTRIAN ACCESS:** The gate opener is intended for installation only on gates used for vehicles. Pedestrians should use a separate entrance to avoid contact with the moving vehicular gate.

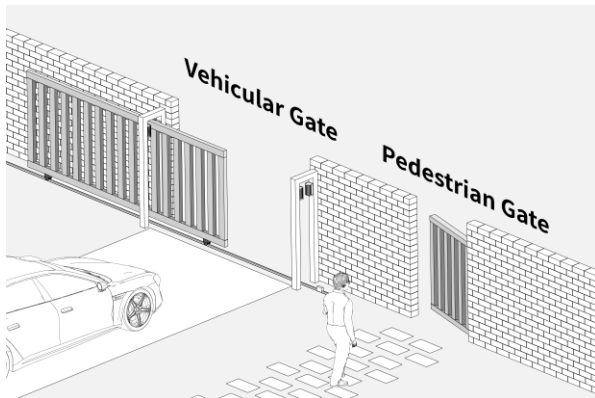

- ◆ **SLIDING GATE PREPARATION:** Ensure that the gate is plumb, level, and slides smoothly in both directions without binding or dragging on the ground. Wheels and guide rollers should rotate easily and be free of dirt or grime. Confirm that the gate track is straight, horizontal, and firmly

affixed. Secure the fence posts in the ground with concrete. Repair or replace all worn or damaged gate hardware prior to installation.

- ◆ **POST OR WALL PROTECTION:** Avoid using the post or wall as a stopping mechanism, either directly or indirectly. This precaution helps protect the post or wall from potential damage due to the impact of the sliding gate.

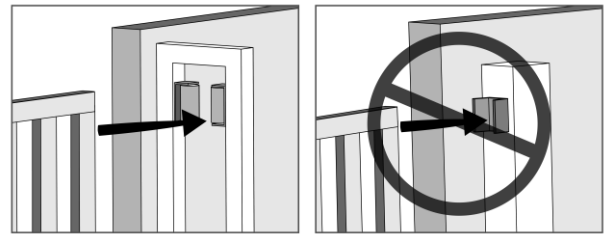

- ◆ **POSITIVE STOPS:** Positive stops must be installed at each end of the gate track to assure that the gate does not exceed its limit of travel and derail while opening or closing fully.

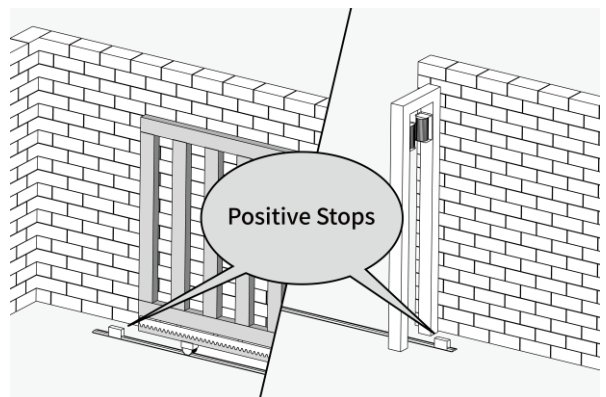

Important Safety Information

During Installation

- ◆ **INSTALLER AND END USER RESPONSIBILITY:** An experienced installer should perform the installation. Improper installation may result in property damage, severe injury or death. The gate opener is only part of the entire gate operating system, and it is the responsibility of the installer and end user to ensure that the total system is safe for its intended use.
- ◆ **DISCONNECT THE POWER SUPPLY:** Ensure that the gate opener is powered off before electrical wire connections or making any adjustments.
- ◆ **INSTALLATION POSITION:** Only install the gate opener on firm, level ground and on the inside of the property or fence line. Ensure there is sufficient clearance between the gate and adjacent structures when opening and closing to minimize the risk of entrapment. Avoid installing it on the outside of the gate where the public has access to it. Avoid installing it in areas prone to flooding or in locations exposed to flammable or explosive fumes.
- ◆ **INSTALL SAFETY SENSOR:** The gate opener is designed to stop or reverse the gate when the gate comes in contact with an obstruction. It is highly recommended to install a photocell sensor in the following situations for safety: if you have children or pets at your property, the gate opener auto close function is set to ON, the gate opener stall force is set to the maximum, a vehicle exit sensor is installed, or other gate

control devices are used.

- ◆ **ENTRAPMENT ATTENTION:** Ensure when the gate is fully open, the end of the sliding gate keeps at least 10cm (4") away from any walls or objects. Exercise caution around moving parts and avoid approaching areas where fingers or hands could get caught. Always keep children, pets and livestock clear of the gate and its path of travel. Never cross the path of a moving gate.

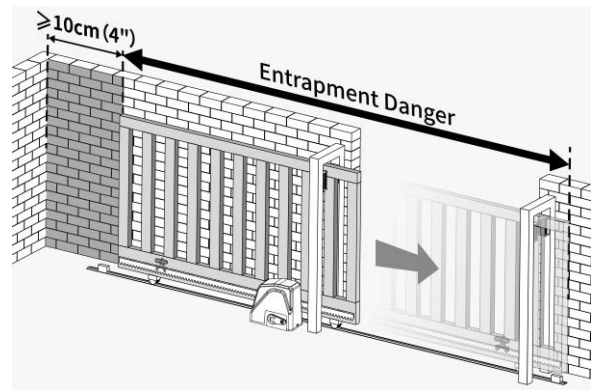

- ◆ **GATE CONTROL ACCESSORIES PLACEMENT:** Gate control accessories intended for user activation must be located at least 1.5 meters (5') away from any moving part of the gate and where the user is prevented from reaching over, under, around or through the gate to operate the controls. Outdoor or easily accessible controls shall have a security feature to prevent unauthorized use.

After Installation

- ◆ **WARNING SIGNS:** Attach the provided warning signs to both sides of the gate in highly visible locations to alert the public about the automatic gate opener system. If your signs are damaged or missing, please reach out to TOPENS Customer Support for replacements.

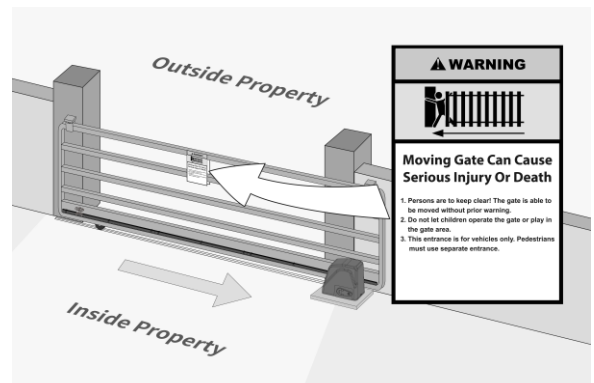

Important Safety Information

- ◆ **AWAY FROM MOVING GATES:** Keep children, pets and livestock away from the gate opener system as moving gates can be dangerous.
- ◆ **SECURE GATE CONTROL ACCESSORIES:** Prevent children from operating or playing with gate controls by keeping remote transmitters, keypads, and push buttons out of their reach. Store in a secure area when not in use.
- ◆ **MAINTENANCE OF GATE OPENER SYSTEM:** Keep the gate properly maintained and its track free of grime and debris. Periodically check that it slides smoothly under manual operation and tighten any loose hardware as needed. Turn off the power to the gate opener before performing any maintenance.
- ◆ **OBSTRUCTION PROTECTION TESTING:** Test the gate opener monthly. The gate must stop or reverse on contact with a rigid object or when an object activates the non-contact sensors. After adjusting the stall force or limit travel, retest the gate opener. Failure to adjust and retest the gate opener properly can increase the risk of injury or death.
- ◆ **POWER DISCONNECTION AND MANUAL OPENING:** Understand how to disconnect the power and manually open the gate. Disconnect the gate opener from the gate only when the gate is not in motion and the gate opener system is turned off.
- ◆ **RECOGNIZE POTENTIAL RISKS IN AUTOMATED GATE SYSTEMS:** Save the installation manual. Make sure everyone who is using or will be around the gate and gate opener are aware of the dangers of automated gate systems. If a replacement manual is needed, you can download a copy from the TOPENS website (www.topens.com).

Note For Warranty

- ◆ **WARRANTY LIMITED TO TARGET MARKET:** The warranty is limited to the target market (Contiguous United States, Canada, UK, and Germany). Customers using the product outside these regions will be responsible for any additional expenses during the warranty replacement process.
- ◆ **GATE OPENER ABUSE:** TOPENS does not cover damage resulting from abuse, such as attempting to operate the gate opener beyond its specified capacity or using it for unintended purposes.
- ◆ **GATE OPENER MISUSE:** TOPENS does not cover damage resulting from misuse, including but not limited to operating the gate opener with incompatible power sources or using it in environments not recommended by TOPENS.
- ◆ **ALTERATIONS OR MODIFICATIONS:** Alterations or modifications made to the gate opener without prior consultation with TOPENS will also invalidate warranty coverage.
- ◆ **NON-COMPLIANCE WITH INSTRUCTIONS:** Failure to follow the installation instructions, including but not limited to improper installation, maintenance will void the warranty.
- ◆ **THIRD PARTY ACCESSORIES:** TOPENS does not cover damage caused by third party accessories, except those specifically recommended by TOPENS Customer Support. It is important to use only compatible accessories to ensure compatibility and prevent damage to the gate opener.
- ◆ **CONTACT TOPENS SUPPORT:** Please ensure that the gate opener is installed, operated, and maintained in accordance with the guidelines outlined in the installation manual to avoid voiding the warranty. If you have any questions regarding proper usage or need assistance with compatible accessories, please contact TOPENS Customer Support for guidance.
- ◆ **DETAILED WARRANTY POLICY:** If you have any questions regarding what is covered by the TOPENS warranty, refer to the policy at www.topens.com/pages/topens-limited-warranty.

Packing List

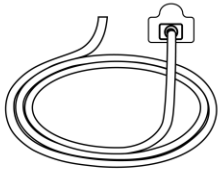

Power Cord

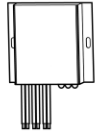

Solar Charge Controller

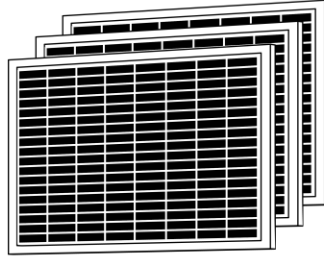

3 x 10W 24V Solar Panel

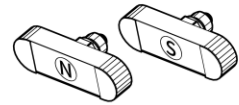

N & S Magnet Assembly

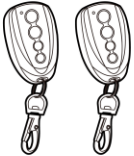

Remote Control

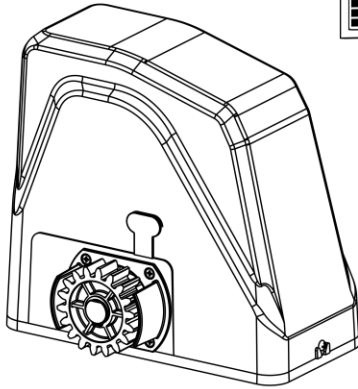

Gate Opener

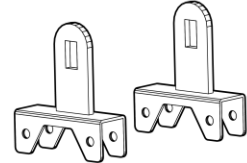

Magnet Bracket

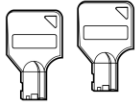

Release Key

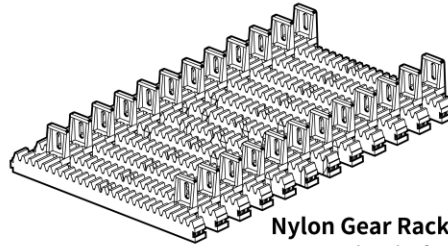

Nylon Gear Rack
12 PCS, total 4m (13 feet)

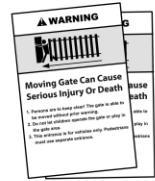

Warning Sign

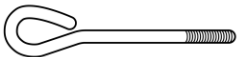

Anchor Bolt (4)



M5x12 Pan Head Screw (8)



Φ10 Plain Washer (4)



Φ10 Lock Washer (4)



M10 Hex Nut (4)

Supplementary Racks

(If the rack is insufficient, additional racks can be purchased separately at www.topens.com.)

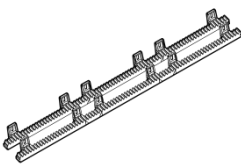

RNH2 Heavy Duty Nylon Gear Rack

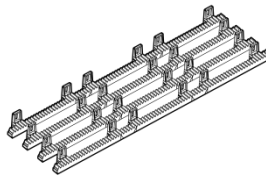

RNH4 Heavy Duty Nylon Gear Rack

Compatible Racks

(Sold Separately)

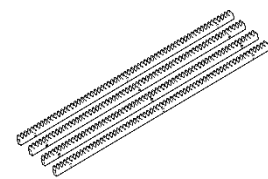

SR02 Heavy Duty Steel Gear Rack

Installation Overview

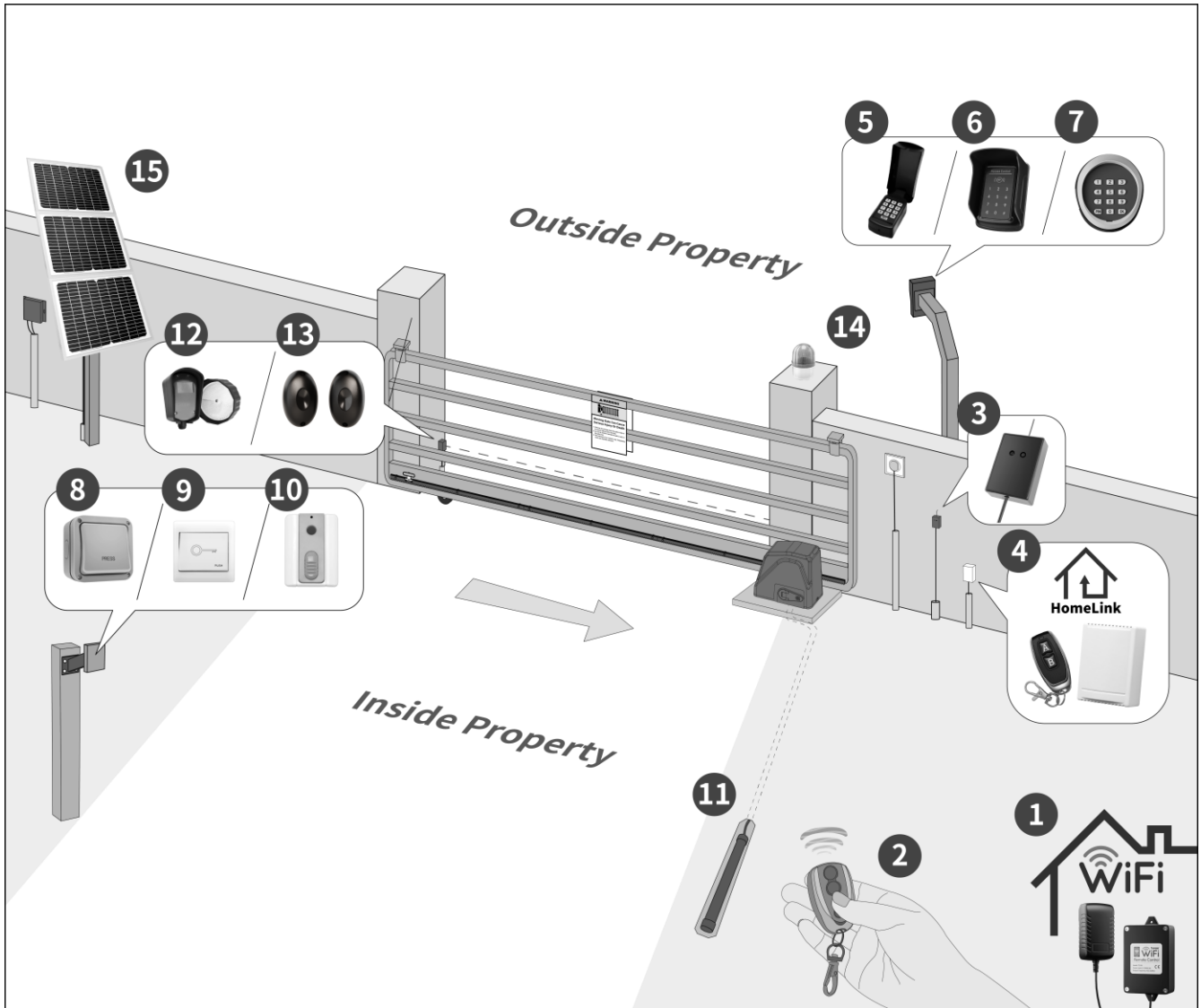

Various TOPENS Accessories for Your Gate Opener System

① TC196 WiFi Remote Control	⑨ TC147 Wall Push Button
② M12 Remote Control	⑩ TC173 Wireless Push Button
③ ERM12 External Receiver	⑪ TEW3 Vehicle Sensor Exit Wand
④ HLR01 Homelink Remote Control Kit	⑫ TRF3 Reflection Photocell Sensor
⑤ TC188 Universal Keypad	⑬ TC102 Infrared Photocell Sensor
⑥ TC175P Wired Keypad	⑭ JD24VY Warning Light
⑦ TKP3 Wireless Keypad	⑮ TSP30W 30W Solar Panel Charging Kit
⑧ TC148 Waterproof Wall Push Button	

* Available on the TOPENS website (www.topens.com) and Amazon.

Specifications

Product Model	DKR1100ST
Power Input	110-120VAC/60Hz
Motor Voltage	24VDC
Motor Power	450W (3/5 HP)
Gate Moving Speed	20 cm/s (8 in/s)
Max Gate Weight	1200kg (2600lbs)
Max Gate Length	12m (40ft.)
Working Temperature	-20°C ~ +50°C (0°F to 120°F)
Protection Class	IP44 Waterproof
Sound Level	< 50 dB

Overall Dimensions

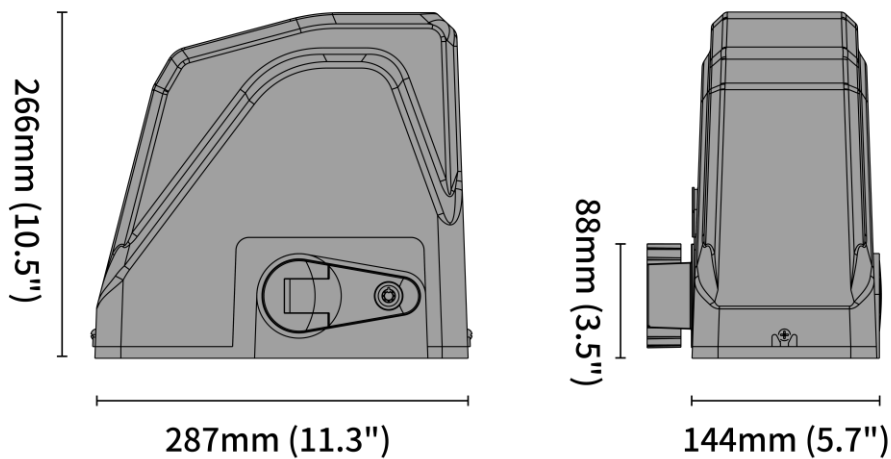

Before You Begin

Check the Gate

- ◆ Ensure that the gate is plumb, level, and slides smoothly in both directions without binding or dragging on the ground.
- ◆ Confirm that the gate track is straight, horizontal, and firmly affixed, with positive stops installed at each end.
- ◆ Make sure the gate wheels and guide rollers rotate freely and are clean of dirt or grime.
- ◆ Ensure that the fence posts are securely set in concrete.
- ◆ Repair or replace all worn or damaged gate hardware before installation.

Tools Needed

- ◆ Power Drill
- ◆ Tape Measure
- ◆ Open End Wrenches - 14# & 17# or Adjustable Wrenches
- ◆ Wire Strippers
- ◆ Level
- ◆ Phillips Screwdriver
- ◆ Slotted Screwdriver

Battery Required

- ◆ When using batteries and solar panels as the main power source, 24V 12Ah batteries are required (NOT included). Marine / automotive type battery or lead acid / GEL / AGM / flooded (deep cycle battery) batteries are supported, EXCEPT for lithium-ion battery. The batteries should be waterproof, or they should be placed in waterproof housing.

Items Not Included but May Needed

- ◆ **PVC Conduit:** Required to protect the cable connecting TC102 infrared photocell sensor to the control board.
- ◆ **Connection Cable:** Connection cable may be required for installing wired accessories. Refer to the Connection of Accessories section in this manual to purchase the correct cable.
- ◆ **Weatherproof Cover:** Use a weatherproof cover to protect the electrical outlet if it is located outdoors.
- ◆ **Surge Protector:** A surge protector with a rated current of 5A is recommended to use with the power cord.

Install Photocell Sensor

- ◆ It is highly recommended to install a photocell sensor in the following situations for safety: if you have children or pets at your property, the gate opener auto close function is set to ON, the gate opener stall force is set to the maximum, a vehicle exit sensor is installed, or other gate control devices are used.

Installation

CAUTION

- ◆ Ensure that the opener is installed in a level and parallel position and is securely fastened.
- ◆ Improper installation may result in property damage, severe injury, and / or death.

STEP 1

Identify the Location of the Power Cord Hole

- ◆ Unscrew the two cover screws located on each side of the motor casing to remove the casing.
- ◆ Check the power cord hole.

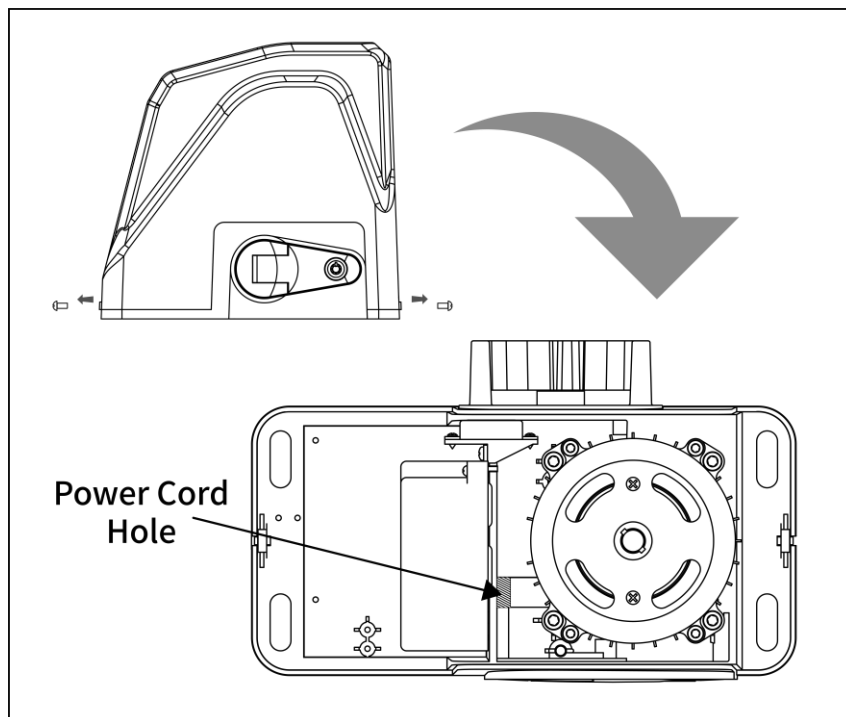

STEP 2

Determine the Position of the Opener

- ◆ Place the opener near the front roller of the gate.
- ◆ Position the rack against the gate. Adjust the opener's position to ensure that the rack teeth are fully engaged with the gear.

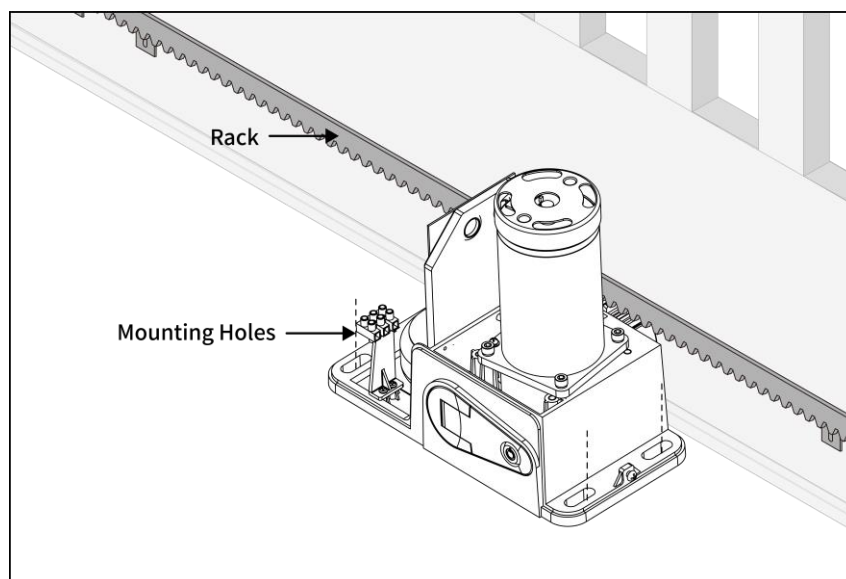

Installation

STEP 3

Lay out the Concrete Pad

- ◆ Dig a hole for the concrete pad at the designated location for the opener. The dimensions should be approximately 400 x 240 x 300mm (15.7" x 9.4" x 12").
- ◆ Install the electrical conduit (right under the power cord hole of the opener).
- ◆ Pour the concrete pad.
- ◆ Before the concrete sets, insert the four anchor bolts, making sure they align perfectly with the mounting holes on the opener base.
- ◆ Ensure that the pad surface is level and parallel to the driveway.
- ◆ Increase the pad height if necessary to protect the system from flooding, heavy snow, etc.

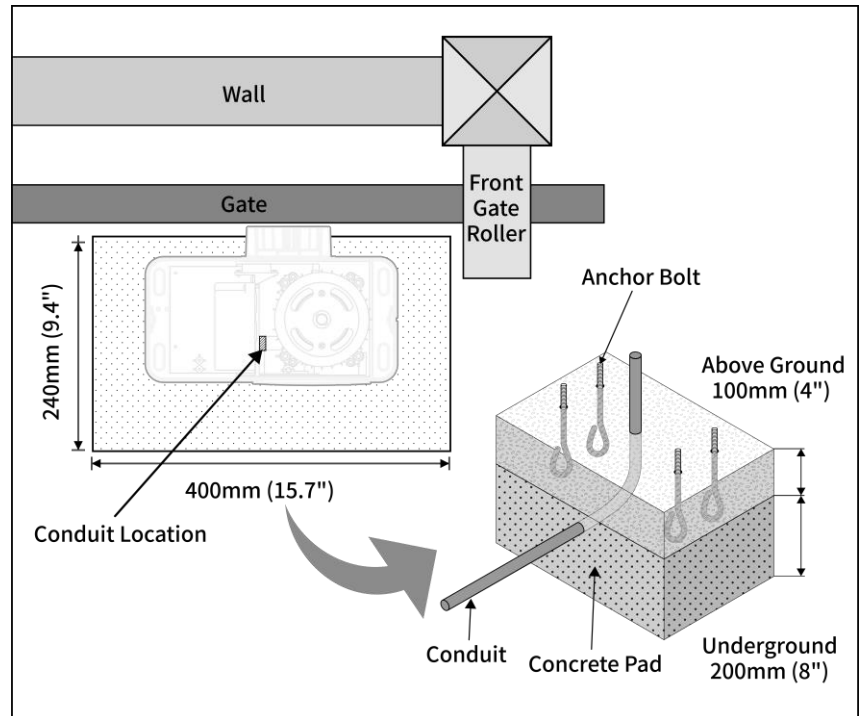

Installation

STEP 4

Install the Opener

- ◆ Attach the opener to the concrete pad, ensuring that it is perfectly parallel to the gate. Secure it to the anchor bolts with M10 Hex Nuts, $\Phi 10$ Lock Washers, and $\Phi 10$ Plain Washers.
- ◆ DO NOT over tighten the nuts, as further adjustments may be needed later.

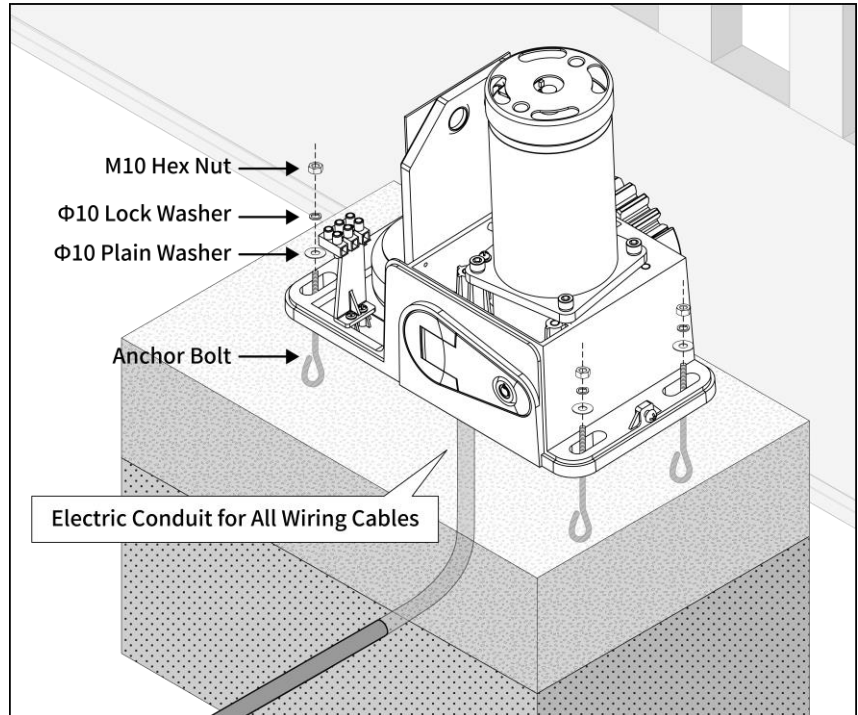

STEP 5

Disengage the Clutch

- ◆ Insert the manual release key and turn it 90° clockwise.
- ◆ Pull the release handle 90° clockwise to disengage the clutch between the gear shaft and the motor.
- ◆ The gate opener is now in manual mode, allowing you to open the gate by hand freely.

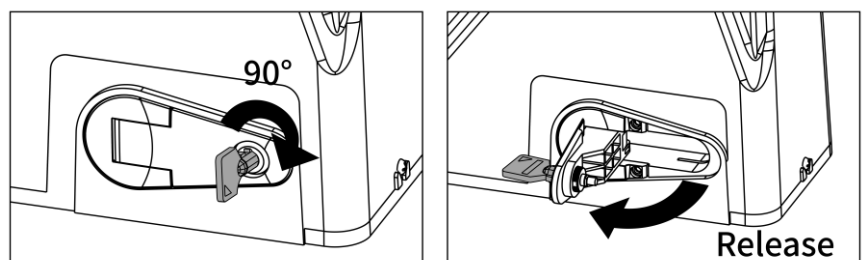

Installation

STEP 6

Fit the Rack (Nylon Gear Rack or Steel Gear Rack)

- ◆ Place the rack on the gear, ensuring that it is level and fully engaged with the gear teeth across their entire thickness.
- ◆ Maintain a 1mm (0.04") gap between the rack and the gear to prevent the weight of the gate from affecting the opener.
- ◆ Secure the nylon gear rack with the included self-threading screws and plates. For the steel gear rack (sold separately), weld the rack nut to the gate, then fasten the steel gear rack with the included hex bolts and plain washers.
- ◆ Repeat the same steps used for the first rack section to install the remaining sections until the desired length is reached.
- ◆ Manually open and close the gate to ensure that the gate moves smoothly with the gear rack installed.
- ◆ Cut away any excess length of the rack. (*Note: the rack must be longer than the actual travel distance of the gate.*)

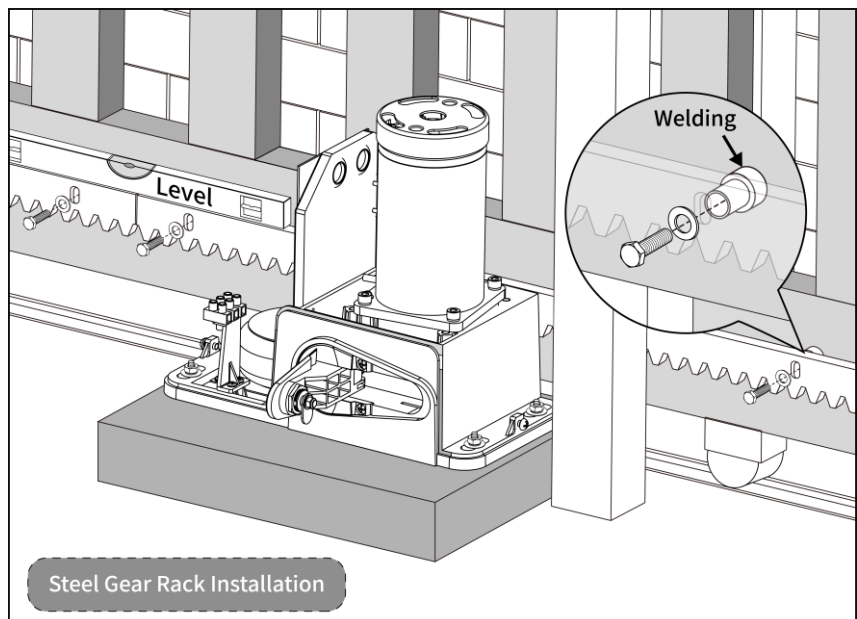
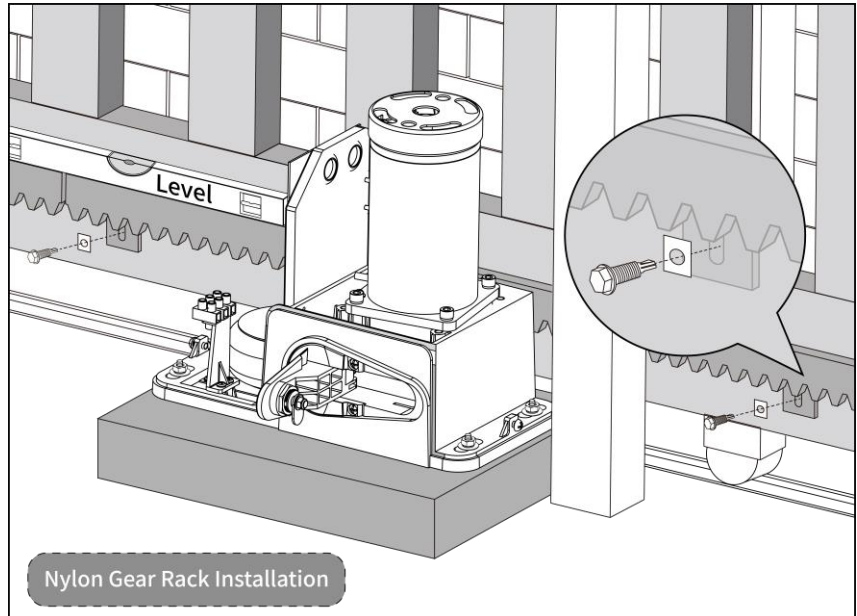

NOTES:

- ◆ Both the nylon gear rack & steel gear rack are compatible.
- ◆ Extra TOPENS original RNH2 & RNH4 Heavy Duty Nylon Gear Racks and SR02 Heavy Duty Steel Gear Rack are available on the TOPENS website (www.topens.com) and Amazon.

Installation

STEP 7

Install the Magnets

- ◆ Attach the N and S magnets to the magnet brackets.
- ◆ From the inside view of the property, install the N magnet bracket on the left side and the S magnet bracket on the right side.
- ◆ Manually close the gate completely and install the appropriate magnet bracket so that the opener stops at the desired closed position when the magnet senses the limit switch. Similarly, fully open the gate and install the appropriate magnet bracket so that the opener stops at the desired open position when the magnet senses the limit switch. Leave some space at both ends of the gate for buffering.
- ◆ Secure the magnet brackets to the rack with M5x12 Pan Head Screws, ensuring that the N and S magnets are 25-30mm (1-1.2") away from the limit switch box. Fine-tune the opener's position if necessary, and then securely tighten all the nuts.
- ◆ Adjust the N and S magnets to ensure that their centers are aligned with the marked line on the limit switch box.

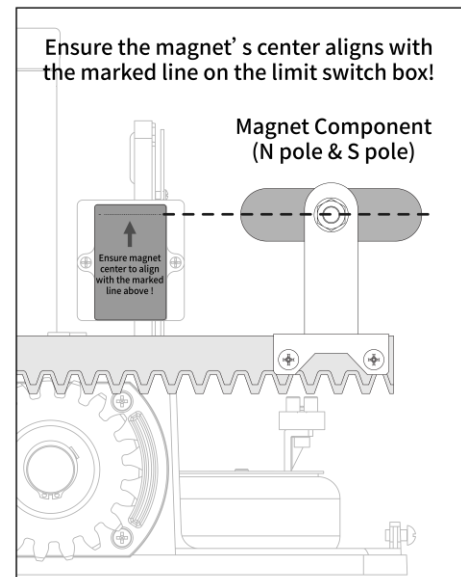
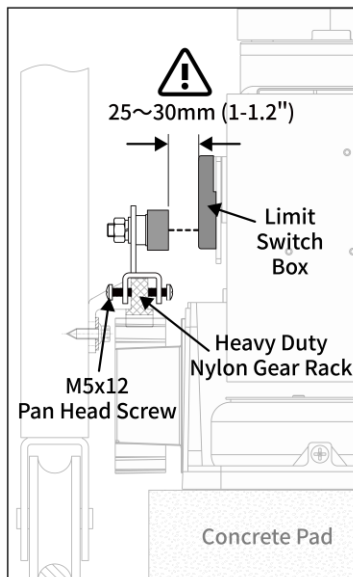
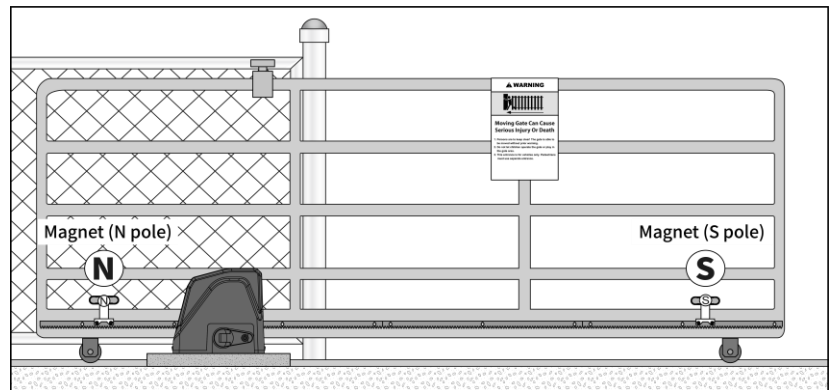
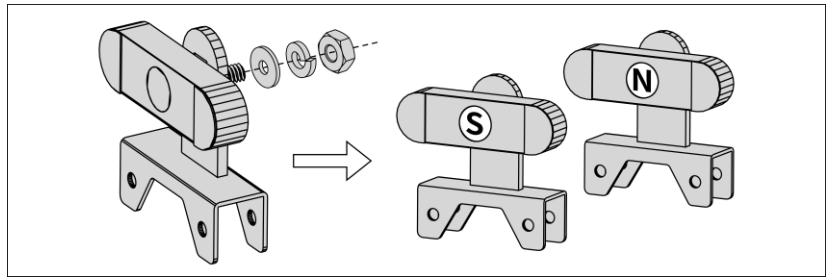

NOTES:

- ◆ Precise installation of the magnets ensures accurate control of the gate's opening and closing positions. You can adjust the open / close limit position according to your needs.
- ◆ Improper installation of the magnets may cause the gate to crash into the end barrier, posing a significant safety risk! It is highly recommended to watch our step-by-step installation video on YouTube for guidance.

STEP 8

Engage the Clutch

- ◆ Pull the release handle 90° counterclockwise.
- ◆ Turn the manual release key 90° counterclockwise and then remove it.

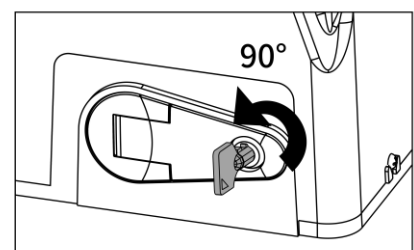
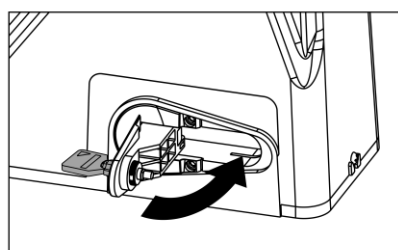

Terminal Function of the Control Board

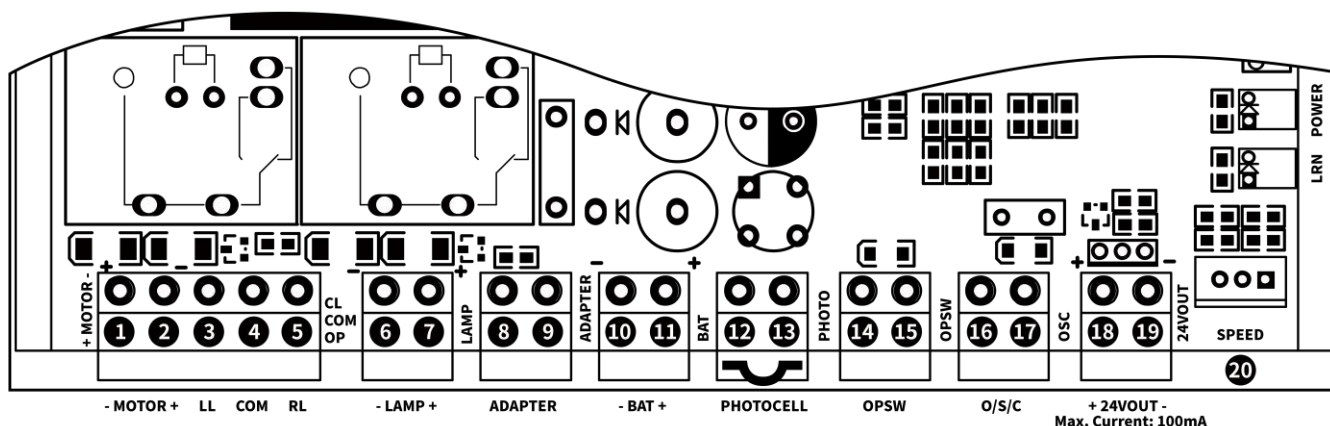

Terminal

Function

①② “-MOTOR+”	Output terminals for motor control, connected to the yellow and red wires of the motor respectively.
③ “LL” ④ “COM” ⑤ “RL”	Input terminals for a normally closed limit switch, connected to the yellow, black and red wires of the limit switch, respectively.
⑥⑦ “-LAMP+”	Output terminals for a warning light, connected to the black and red wires of the warning light respectively. Ensure that the warning light has a rated voltage of 24VDC and a rated current of less than 1A.
⑧⑨ “ADAPTER”	Input terminals for a power adapter. Reserved for use.
⑩⑪ “-BAT+”	Input terminals for 24VDC power, typically connected to the negative and positive terminals of a 24VDC battery or 24VDC power supply, providing power to the entire system or other 24VDC accessories.
⑫⑬ “PHOTOCELL”	Receive signal input from a photocell sensor, operating on a normally closed (NC) input basis, connected to “COM” and “NC” terminals of the sensor respectively. Note: The terminals have been shorted with a wire jumper at the factory.
⑭⑮ “OPSW”	Accept the signal input of the gate opening, usually connected to the normally open output of a vehicle sensor.
⑯⑰ “O/S/C”	Control gate operation through a normally open dry contact signal input, commonly connected to push button, wired keypad, and external receiver for cyclic gate operation (open/stop/close/stop).
⑱⑲ “+24VOUT-” Max. Current: 100mA	Provide 24VDC voltage output to power a wired keypad, external receiver, photocell sensor, exit wand and Homelink remote control kit.
⑳ “SPEED”	Receives signal input from a motor rotation sensor, typically connected to the hall sensor, to detect the motor rotation cycles during gate opening and closing.

NOTE: For terminal wiring, remove the terminal from the control board and unscrew the terminal screws using a screwdriver. Insert the wire into the terminal, tighten the screws to secure the wire, and then reattach the terminal to the control board.

Connection of Power Supply

WARNING

- ◆ A professional electrician is required for wire connection to avoid the risk of injury, electric shock, or death. NEVER connect the gate opener to an electrical outlet before all the installations have been done.
- ◆ It is recommended to use a surge protector with a rated current of 5A with the power cord. Protect the electrical outlet with a weatherproof cover if it is located outdoors.

Power Mode 1

By Solar Panels and Batteries

- ◆ Connect the LOAD wires of the TCS3 Solar Charge Controller to the “-BAT+” terminals of the control board.
- ◆ Connect two 12VDC batteries in series to achieve 24VDC (batteries not included).
- ◆ Connect the BAT wires of the TCS3 solar controller to the batteries.
- ◆ Assemble the solar panels, connect them in parallel, and mount them in an area clear of obstructions and shading from buildings and trees. The solar panel should face south if it is located north of the equator. If it is located south of the equator, it should face north.
- ◆ Connect the SOLAR wires of the TCS3 solar controller to the solar panels.

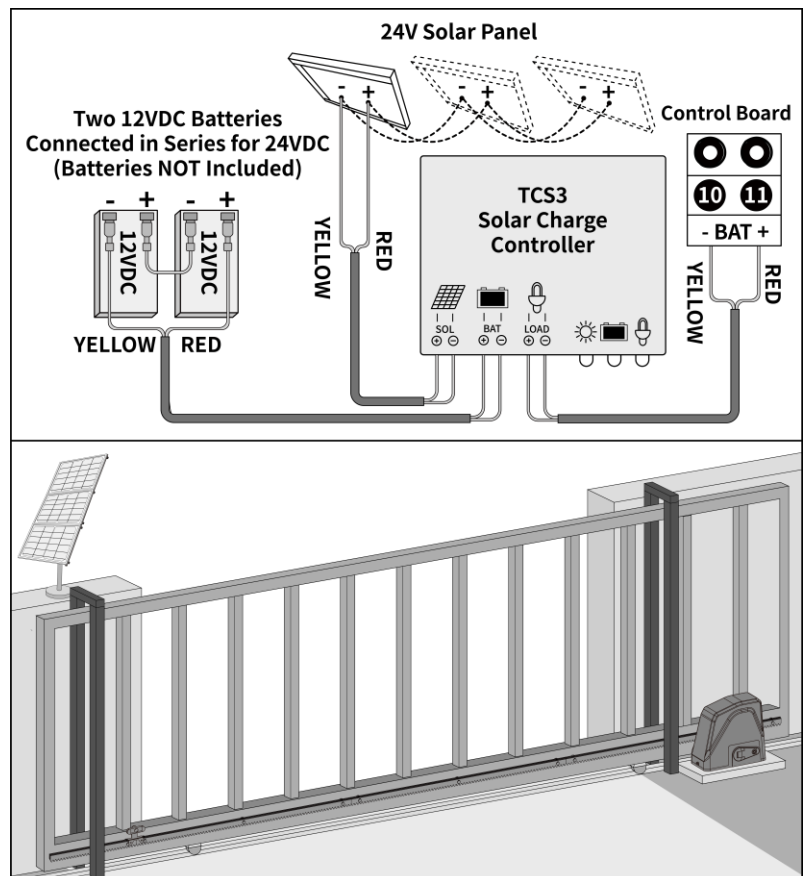

NOTES ABOUT THE BATTERY AND SOLAR PANEL

- ◆ The batteries should be waterproof, or they should be placed in waterproof housing.
- ◆ The TCS3 Solar Charge Controller supports a maximum solar panel power of 240W, exceeding this limit can cause damage to it.
- ◆ If the gate opener is solely powered by battery and utilizes the solar panel for charging, a minimum of a 24VDC 12Ah automotive / marine type battery and a 24V 30W solar panel are required.
- ◆ If there are more than 6 hours of sunlight per day and no accessories are connected (except for the push button and warning light), the gate opener can operate 10 cycles per day.
- ◆ Add more solar panels and increase battery capacity if there is less than 6 hours of sunlight per day or if using any accessories (such as a photocell sensor, external receiver, Homelink remote control kit, exit wand, or wired keypad).
- ◆ For precise recommendations on solar panel power and battery capacity, please contact our customer support at www.topens.com.

Connection of Power Supply

Power Mode 2

By AC Electricity, Solar Panels and Back-up Batteries

- ◆ Connect the BAT wires of the TCS3 Solar Charge Controller and the wires connecting to the batteries in parallel (Do NOT connect the batteries).
- ◆ Connect the parallel wires to the “-BAT+” terminals of the control board.
- ◆ Tape the LOAD wires of the TCS3 solar controller to prevent a short circuit.
- ◆ Connect two 12VDC batteries in series to achieve 24VDC (batteries not included).
- ◆ Connect the batteries to the “-BAT+” terminals of the control board.
- ◆ Assemble the solar panels, connect them in parallel, and mount them in an area clear of obstructions and shading from buildings and trees. The solar panel should face south if it is located north of the equator. If it is located south of the equator, it should face north.
- ◆ Connect the SOLAR wires of the TCS3 solar controller to the solar panels.
- ◆ Connect the live wire (black), neutral wire (white) and earth wire (green) of the power cord to the “L”, “N” and “PE” terminals, respectively.
- ◆ Plug the power cord into an electrical outlet.

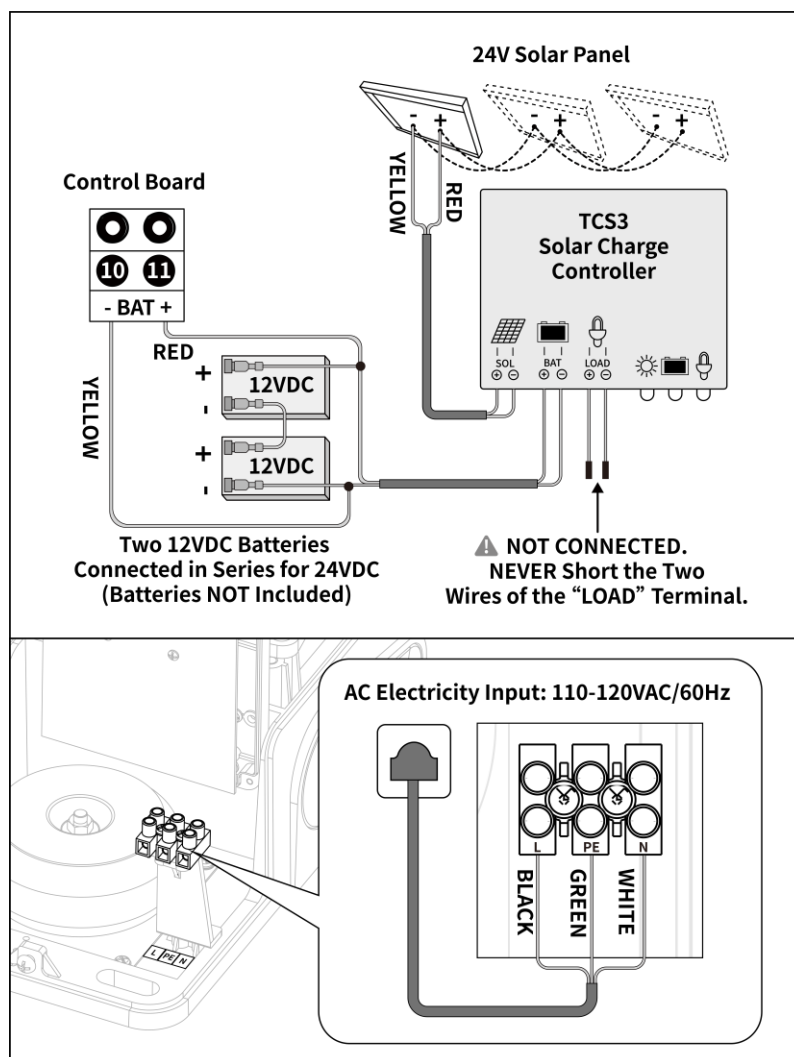

NOTES ABOUT THE BATTERY AND SOLAR PANEL

- ◆ The batteries should be waterproof, or they should be placed in waterproof housing.
- ◆ The TCS3 Solar Charge Controller supports a maximum solar panel power of 240W, exceeding this limit can cause damage to it.
- ◆ If the gate opener is powered by backup batteries and utilizes both AC electricity and solar panel for charging, a minimum of a 24VDC 7Ah automotive / marine type battery and a 24V 20W solar panel are required.

Connection of Power Supply

Power Mode 3

Use AC Electricity Only

- ◆ The specification of the power cord is $3C \times 0.75\text{mm}^2$ (18AWG).
- ◆ Connect the live wire (black), neutral wire (white) and earth wire (green) of the power cord to the “L”, “N” and “PE” terminals, respectively.
- ◆ Plug the power cord into an electrical outlet.

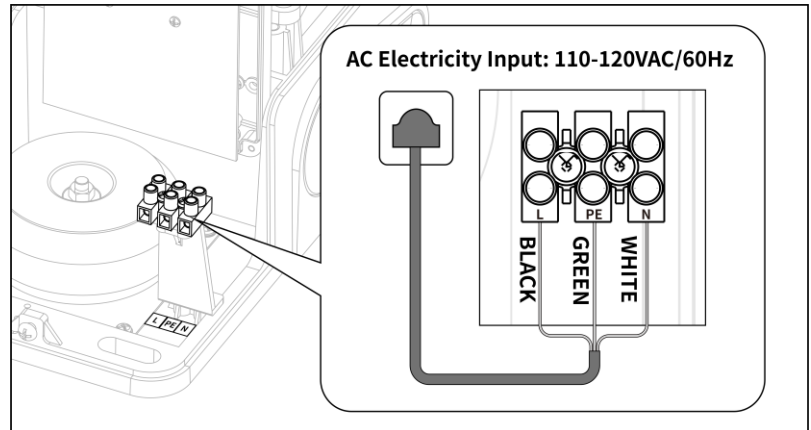

Power Mode 4

By AC Electricity and Back-up Batteries

- ◆ If the AC power failures occur for less than 8 hours per day, you can use a minimum of 24VDC 5Ah automotive / marine type battery as a backup power source while using AC electricity to charge the battery.
- ◆ Connect two 12VDC batteries in series to achieve 24VDC (batteries not included).
- ◆ Connect the batteries to the “-BAT+” terminals of the control board.
- ◆ Connect the live wire (black), neutral wire (white) and earth wire (green) of the power cord to the “L”, “N” and “PE” terminals, respectively.
- ◆ Plug the power cord into an electrical outlet.

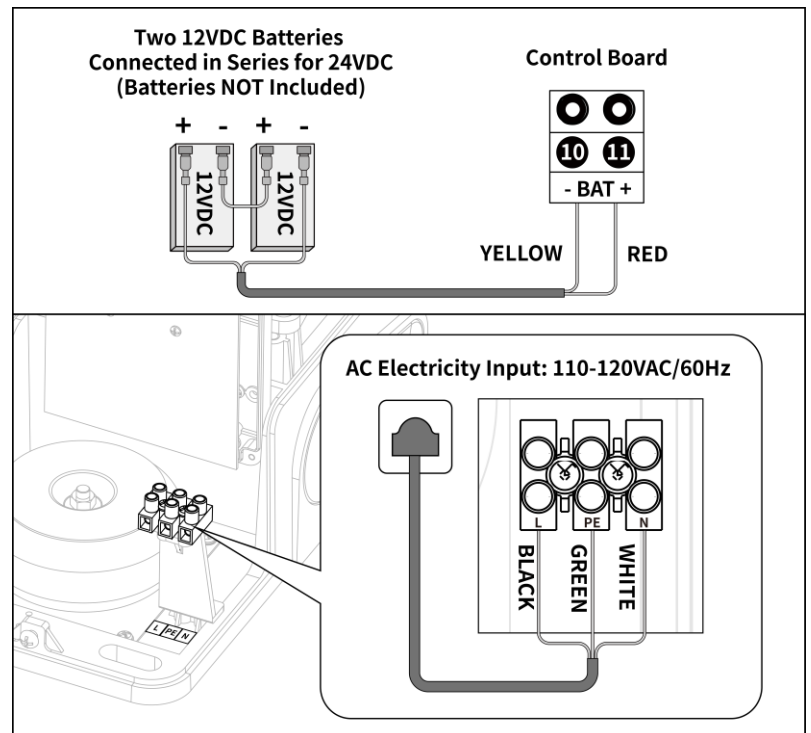

Setting of Left / Right Open

WARNING

- ◆ Before operating your gate opener, ensure that the Left / Right Open setting on the control board matches the opening direction of the gate.
- ◆ If the opener is installed on the left side of the driveway and the gate opens to left, set the opener to **Left Open**. If the opener is installed on the right side of the driveway and the gate opens to right, set the opener to **Right Open**.
- ◆ Please refer to the DIP Switch Settings section for detailed instructions.

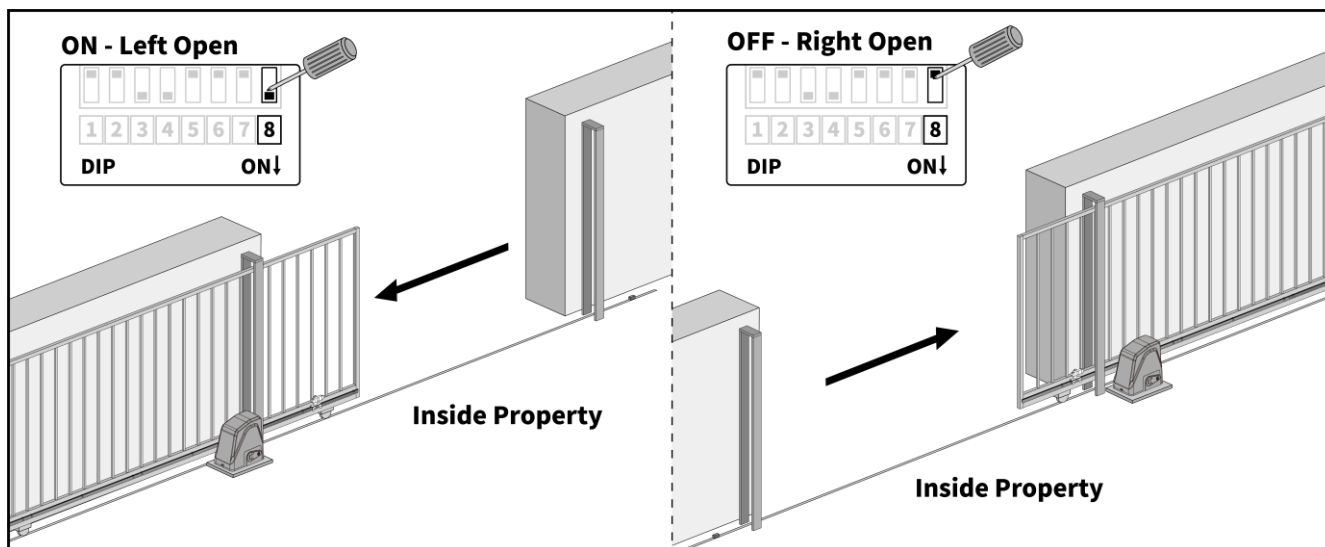

Program the Remote Control

NOTES

- ◆ *Keep the gate movement area free of obstructions, and ensure children, pets and livestock stay away from the gate opener system while the gate is in motion.*
- ◆ *If you lose any remote control, please erase and reprogram all remaining remote controls for safety.*

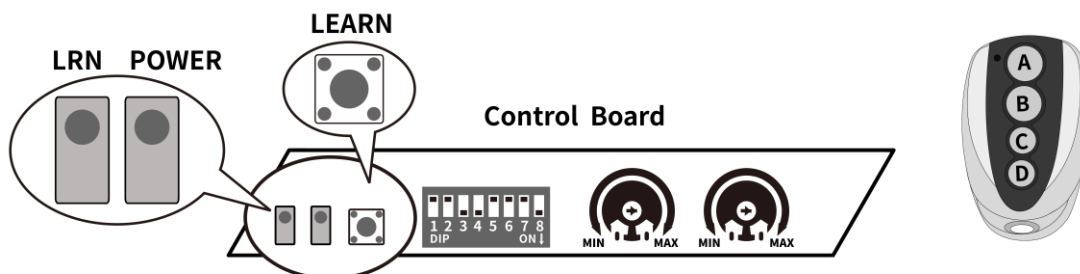

Function of the Remote Control Button

- ◆ Each remote has four buttons, from top to bottom are separately A, B, C and D.
- ◆ For the sliding gate opener, button A is used to be programmed with the gate opener for standard operation. Once button A is programmed, button B automatically activates midway mode to partially open the gate for quick passage. If the midway mode function is disabled, button B functions the same as button A. Buttons C and D can be programmed separately to operate additional sliding gate openers by adding extra ERM12 External Receivers (available on the TOPENS website www.topens.com) to each control board, allowing for standard operation without midway mode.
- ◆ Each press of the programmed button A cycles the gate through open, stop, close, stop, and open. With the ERM12 external receiver, the programmed buttons C and D can also control the gate with the same open, stop, close, stop, and open cycle.

How to Program the Remote Control

The remote control **MUST** be programmed to the gate opener before use. The remote controls that come with the gate opener are preprogrammed.

If you purchase additional remote controls, or if the programmed remotes are not working, repeat the programming steps below for each remote control.

Enter Programming Mode

- ◆ Press and release the LEARN button on the control board. The LRN LED will turn on, indicating that the gate opener is now in programming mode.

Program the Remote Control

- ◆ Press the remote control button you want to program once, then press it again after the LED on the remote turns off.
- ◆ The LRN LED will flash for 3 seconds and then turn off, indicating successful programming.

Additional Remote Controls

- ◆ The gate opener can pair Max. 8 M12 remote controls on its own, and up to 250 with the ERM12 External Receiver (sold separately on the TOPENS website www.topens.com).

How to Erase All Programmed Remote Controls

- ◆ Press and hold the LEARN button until the LRN LED turns from ON to OFF. Now all programmed remote controls have been erased.

Adjust the Open / Close Limit Position

WARNING

- ◆ Before making any adjustments, disengage the clutch of the gate opener to prevent the gate from moving unexpectedly.
- ◆ Ensure that the N magnet bracket is always positioned on the left side and the S magnet bracket on the right side when viewed from inside the property. Leave some space at both ends of the gate for proper buffering.

For Left Open Gate

Adjusting the Open Limit Position

- ◆ Use the remote control to open the gate. If the gate stops halfway and fails to get to the desired open position, disengage the clutch. Use a screwdriver to loosen the screws on the **S (right)** magnet bracket. Gently shift the magnet bracket slightly to the right, then tighten the screws firmly. Engage the clutch and test the gate.
- ◆ If the gate opens over the desired open position, adjust the **S** magnet bracket slightly to the left. Tighten the screws securely.
- ◆ Repeat the above steps until the gate automatically stops at the desired open position.

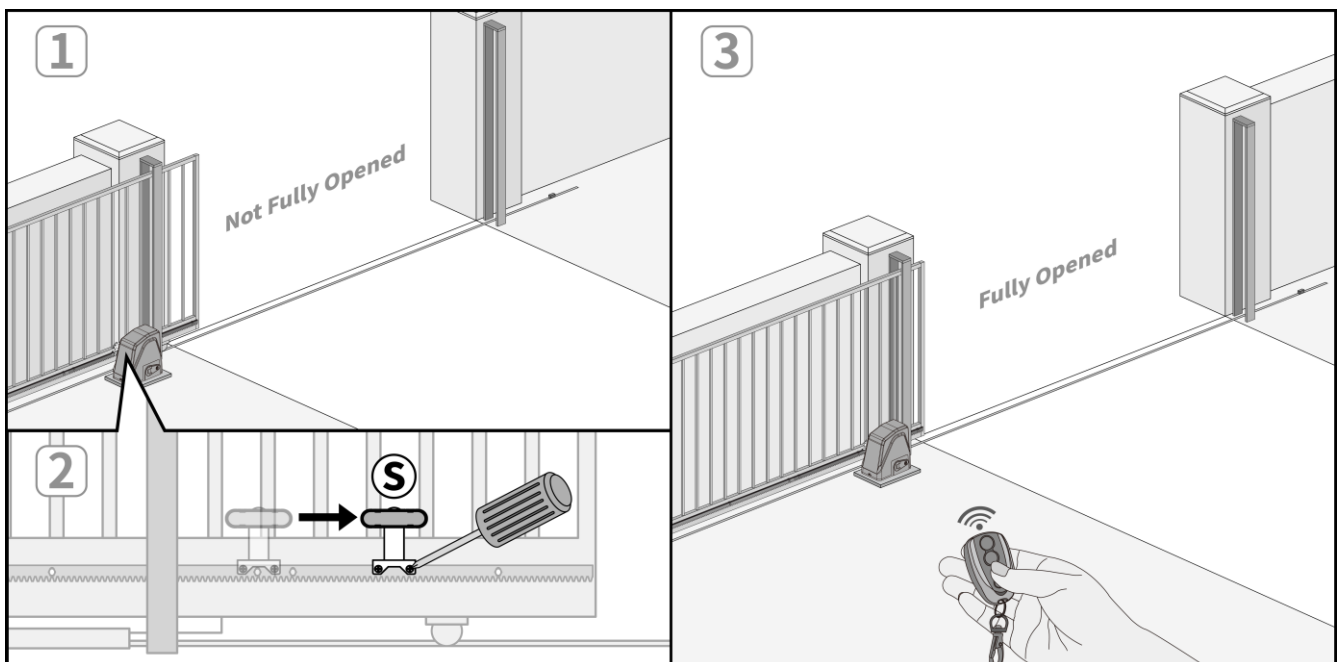

Adjusting the Close Limit Position

- ◆ Use the remote control to close the gate. If the gate stops halfway and fails to get to the desired closed position, disengage the clutch. Use a screwdriver to loosen the screws on the **N (left)** magnet bracket. Carefully move the magnet bracket slightly to the left, then tighten the screws firmly. Engage the clutch and test the gate.
- ◆ If the gate closes over the desired closed position, adjust the **N** magnet bracket slightly to the right. Tighten the screws securely.
- ◆ Repeat the above steps until the gate automatically stops at the desired closed position.

Adjust the Open / Close Limit Position

For Right Open Gate

Adjusting the Open Limit Position

- ◆ Use the remote control to open the gate. If the gate stops halfway and fails to get to the desired open position, disengage the clutch. Use a screwdriver to loosen the screws on the **N (left)** magnet bracket. Gently shift the magnet bracket slightly to the left, then tighten the screws firmly. Engage the clutch and test the gate.
- ◆ If the gate opens over the desired open position, adjust the **N** magnet bracket slightly to the right. Tighten the screws securely.
- ◆ Repeat the above steps until the gate automatically stops at the desired open position.

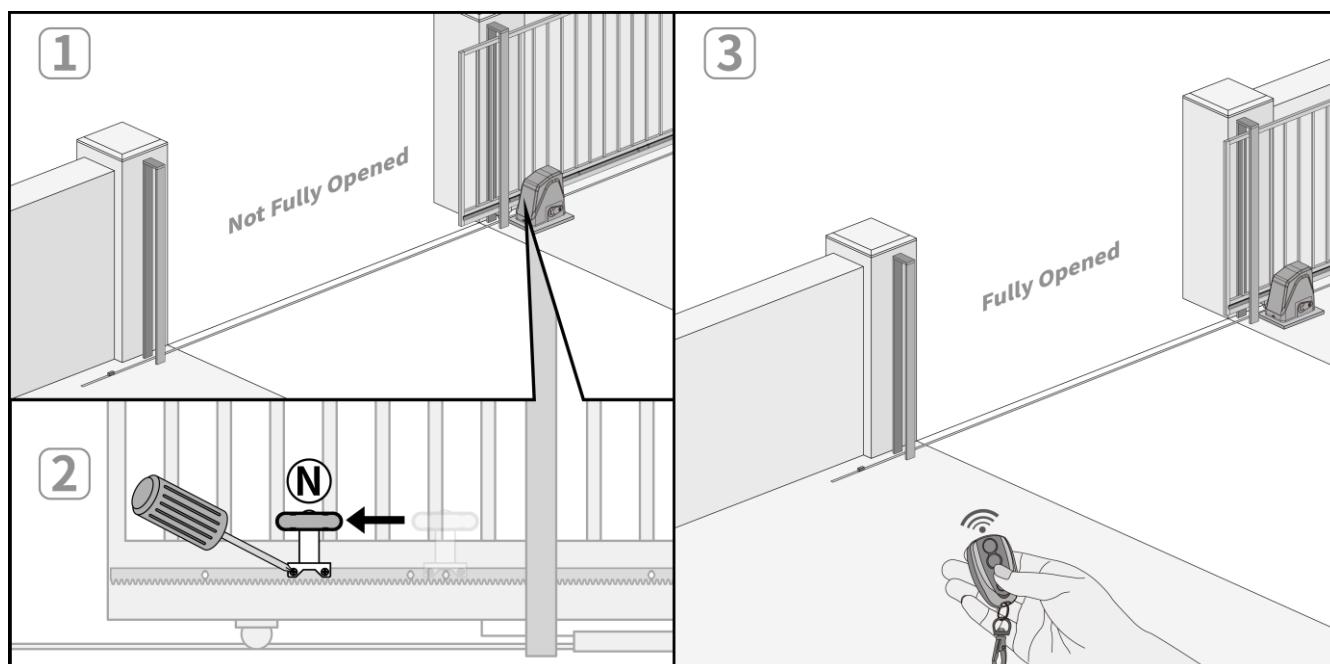

Adjusting the Close Limit Position

- ◆ Use the remote control to close the gate. If the gate stops halfway and fails to get to the desired closed position, disengage the clutch. Use a screwdriver to loosen the screws on the **S (right)** magnet bracket. Carefully move the magnet bracket slightly to the right, then tighten the screws firmly. Engage the clutch and test the gate.
- ◆ If the gate closes over the desired closed position, adjust the **S** magnet bracket slightly to the left. Tighten the screws securely.
- ◆ Repeat the above steps until the gate automatically stops at the desired closed position.

Setting of the Control Board

WARNING

- ◆ Ensure that the gate opener is powered off when making any adjustments.
- ◆ Keep away from the gate while setting up the gate opener system to avoid unexpected gate movement.
- ◆ Carefully adjust the DIP switches to prevent the risk of damaging the gate opener and causing injury or death.
- ◆ Always seek assistance from a professional technician or electrician if you have any questions.

DIP Switch Settings

There are eight DIP Switches located on the main control board (as shown) that must be positioned correctly for your particular installation.

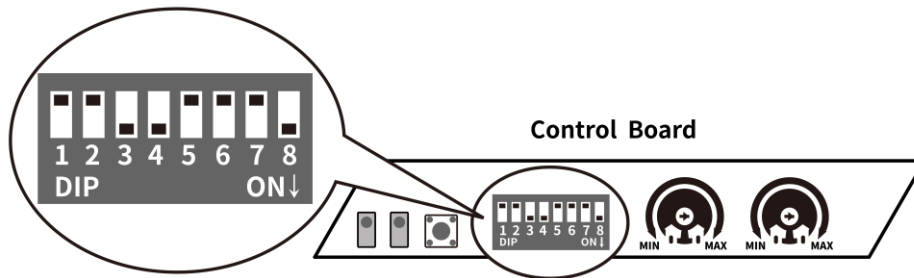

DIP Switch #1 - #2: Set the Running Time of the Motor in Midway Mode

The midway mode allows the gate to partially open for quick passage.

DIP Switch #	ON Position	OFF Position
1	2 Seconds	0 Second (Factory Default)
2	4 Seconds	0 Second (Factory Default)

IMPORTANT NOTES:

- ◆ The midway mode function is disabled when both DIP switches are set to OFF by default.
- ◆ The running time of the motor in midway mode is DIP Switch #1 + DIP Switch #2.
- ◆ Press button B on the remote control to activate the midway mode when the gate is in fully closed position.

Midway Mode:

1. Gate is in the fully closed position.
2. DIP Switch #1 and DIP Switch #2 are set to ON.
3. Press button B on the remote control to open the gate.

→ Gate will open for 6 seconds and then stop automatically.

Setting of the Control Board

DIP Switch #3 - #5: Set the Soft Stop Period of the Motor

The soft stop feature slows down the gate during the final phase before it fully stops, protecting the motor.

DIP Switch #	ON Position	OFF Position
3	1 Second (Factory Default)	0 Second
4	2 Seconds (Factory Default)	0 Second
5	3 Seconds	0 Second (Factory Default)

IMPORTANT NOTES:

- ◆ The factory default soft stop period is 3 seconds.
- ◆ The soft stop period of the motor is DIP Switch #3 + DIP Switch #4 + DIP Switch #5.
- ◆ After each power-off restart of the gate opener, use an access control device (such as a remote or push button) to run a complete open and close cycle to calibrate the full open and close times. This will ensure the soft stop is effective in subsequent cycles.

DIP Switch #6 - #7: Set the Auto Close Time of the Gate Opener

The auto close function allows the gate to automatically close after a set period.

DIP Switch #	ON Position	OFF Position
6	30 Seconds	0 Second (Factory Default)
7	60 Seconds	0 Second (Factory Default)

IMPORTANT NOTES:

- ◆ The auto close function is disabled when both DIP switches are set to OFF by default.
- ◆ The auto close time of the gate opener is DIP Switch #6 + DIP Switch #7.
- ◆ The auto close function should be enabled if a vehicle sensor exit wand is installed.
- ◆ When the auto close function is enabled, the photocell sensor is highly recommended to be installed with the gate opener for safety.

DIP Switch #8: Set Left / Right Open

DIP Switch #	ON Position	OFF Position
8	Left Open (Factory Default)	Right Open

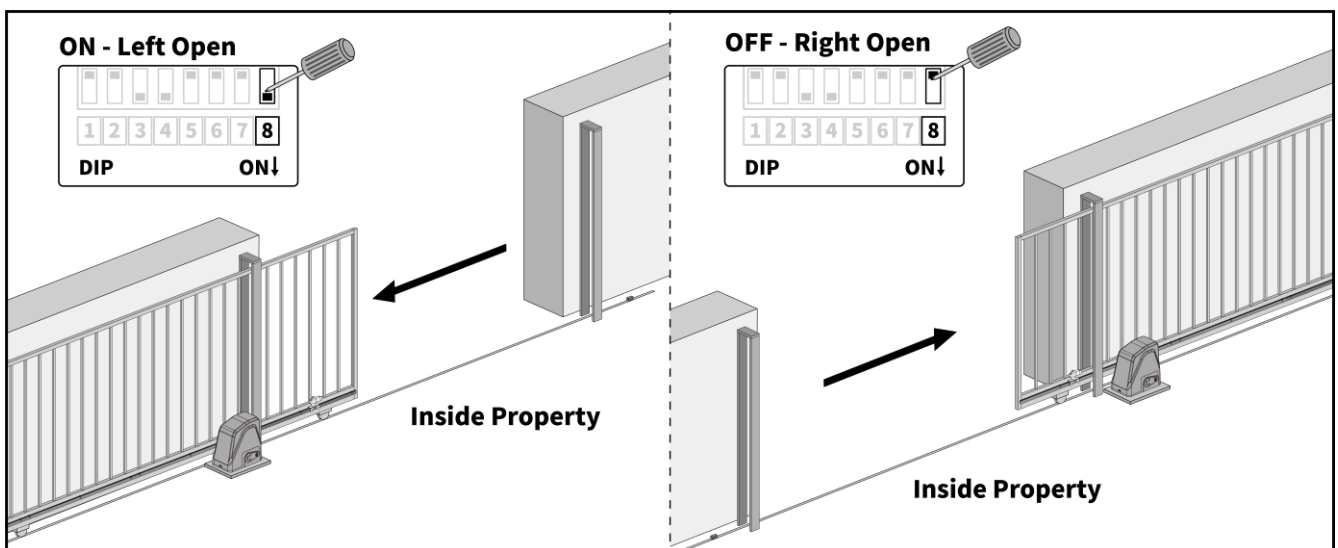

Setting of the Control Board

Potentiometer Settings

Stall force regulates the gate's sensitivity to obstacles during operation. A higher stall force setting decreases sensitivity, making the gate less likely to detect objects. Conversely, a lower stall force setting increases sensitivity, causing the gate to stop or reverse more readily when encountering even minor obstructions.

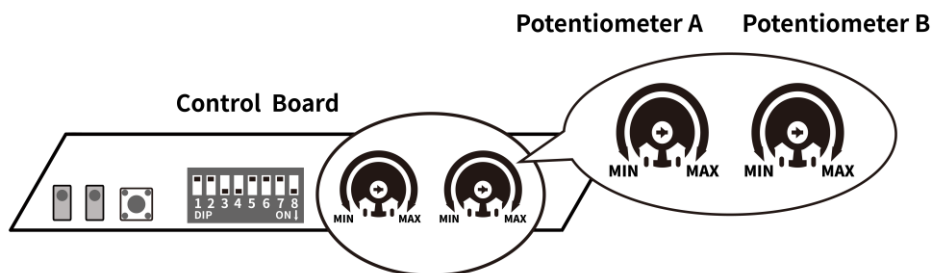

Potentiometer A: Adjust the Close Stall Force of the Gate Opener

Turn the potentiometer clockwise to increase the close stall force, and counterclockwise to decrease it.

Potentiometer B: Adjust the Open Stall Force of the Gate Opener

Turn the potentiometer clockwise to increase the open stall force, and counterclockwise to decrease it.

Stall Force Adjustment & Obstruction Test

Fine Tune the Stall Force

This force should be high enough to ensure the gate reaches both open and close limits without reversing unnecessarily or causing frequent interruptions, but low enough to prevent injury if an obstruction is encountered. The appropriate stall force settings depend on the gate's length and weight, so fine-tuning may be required. Follow these steps to adjust the stall force:

- ◆ **Initial Assessment:** Use the remote control to open and close the gate, observing its movement.
- ◆ **Adjust the Stall Force:** If the gate reverses or stops before reaching the fully closed or open position, increase the stall force by turning Potentiometer A or B slightly clockwise.
- ◆ **Perform the Obstruction Test:** Run the test after each force setting adjustment (see below).

Obstruction Test

This test ensures that the gate opener's automatic obstruction-sensing feature functions correctly. The gate should have enough force to reach both open and close limits, but **MUST** stop or reverse after contacting with a solid object.

- ◆ **Operate the Gate:** Open and close the gate with the remote control, ensuring that it stops at the proper open and close limit positions.
- ◆ **Setup for the Test:** Place a solid, immovable object in the gate's path to simulate an obstruction.
- ◆ **Test Gate's Closing:** Run the gate in the closing direction towards the obstruction. The gate should reverse upon contact with the solid object. If it does not, slightly decrease the Close Stall Force by turning Potentiometer A on the control board counterclockwise (towards MIN).
- ◆ **Test Gate's Opening:** Perform the same test with the gate moving in the opening direction. The gate should stop upon contact with the solid object. If it does not, adjust the Open Stall Force by turning Potentiometer B accordingly.

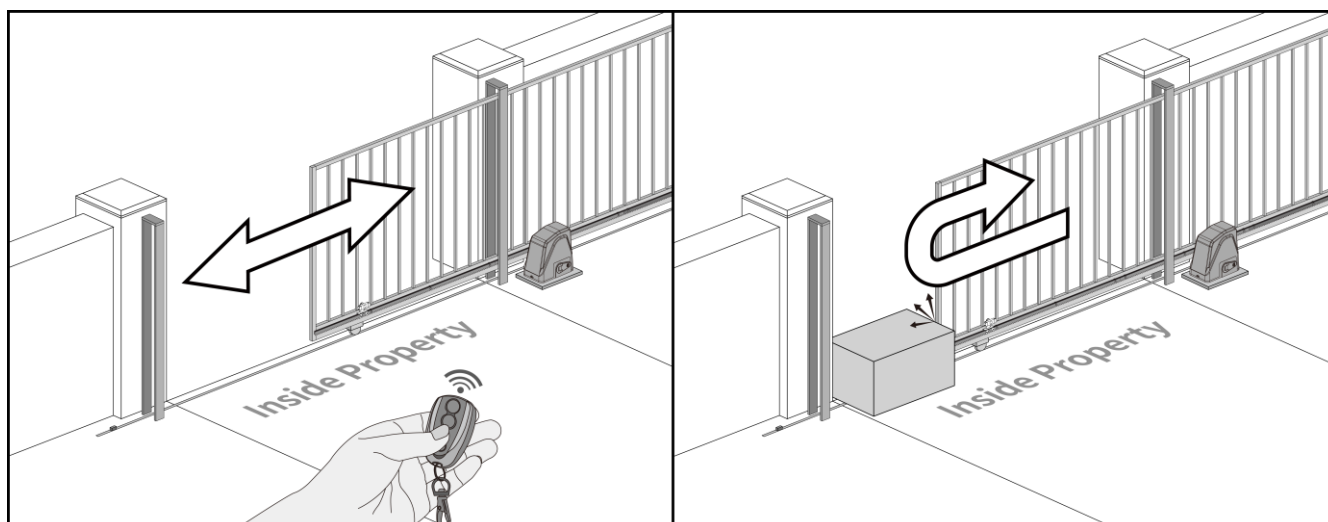

NOTES:

- ◆ If the stall force is set too low (i.e., the sensitivity is too high), the gate may stop or reverse too easily, even with minimal obstruction or resistance, such as strong wind or heavy snow.
- ◆ The gate opener is designed to reverse the gate when the gate comes in contact with an obstruction during closing and to stop the gate during opening. It is highly recommended to install a photocell sensor for additional safety.
- ◆ Always perform an obstruction test for the gate each time you set up the control board or restart it after a power outage.

Connection of Accessories

NOTES

- ◆ This section covers only the programming and wire connections with the control board. For additional operations, please refer to the corresponding accessory user manual.
- ◆ It is highly recommended to install a photocell sensor in the following situations for safety: if you have children or pets at your property, the gate opener auto close function is set to ON, the gate opener stall force is set to the maximum, a vehicle exit sensor is installed, or other gate control devices are used.

TC188 Universal Keypad

Operate the gate using a user-defined password. You can use this keypad wirelessly or wire it to the gate opener according to your needs.

Wireless Mode Programming and Operation

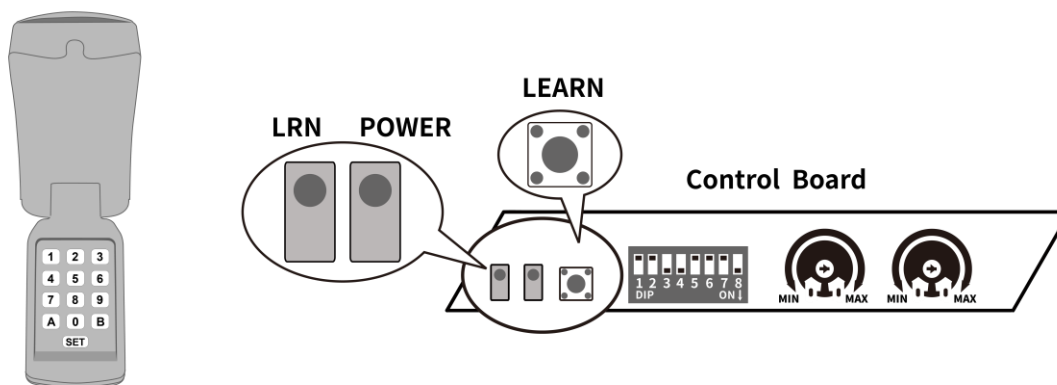

Step 1 Program New Master Code

Factory default master code is 9999, all codes should be 4 digits in length.

SET 4 digits Old Master Code SET 01 SET 4 digits New Master Code SET 4 digits New Master Code SET

Step 2 Add New Permanent Entry Code

SET Master Code SET 02 SET Entry Code SET Entry Code SET

Step 3 Program with the Gate Opener

- ◆ Input the entry code of the keypad.
- ◆ Press and release the LEARN button on the control board. The LRN LED will turn on, indicating that the gate opener is now in programming mode.
- ◆ Press the button A (or B) once, and the keypad LED backlight will flash quickly. Press it again after the backlight changes from a rapid flash to a slow flash.
- ◆ The LRN LED will flash for 3 seconds and then turn off, indicating successful programming.

Step 4 Operate the Gate Opener

Input the entry code and then press the programmed button A (or B) to operate the gate. Within 3 seconds of pressing button A (or B), you can press the button again without re-entering the code to operate the gate.

Connection of Accessories

Wired Mode Connection and Operation

Step 1 Remove the Battery

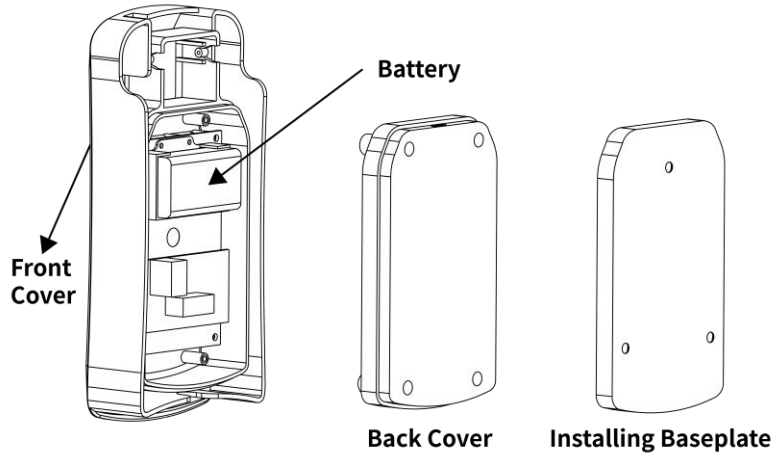

Step 2 Wire Connection

Connect the “COM” and “NO” terminals to control board terminals ⑯ and ⑰ “O/S/C” . Then connect the “9-24V AC/DC” terminals to control board terminal ⑰ “O/S/C” and terminal ⑱ “+24VOUT” . Polarity does not matter for these connections.

NOTE: A 4C x 0.3 mm² (22AWG) cable is required for the wire connection, but it is NOT included.

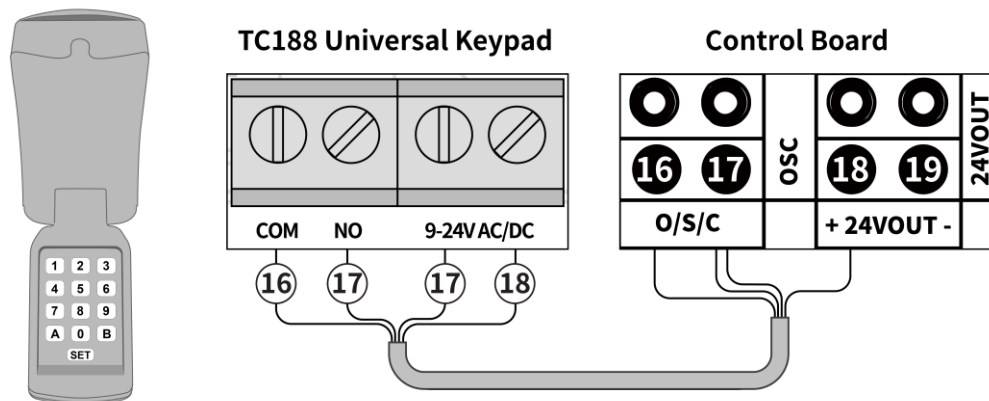

Step 3 Program New Master Code

Factory default master code is 9999, all codes should be 4 digits in length.

SET 4 Digits Old Master Code SET 01 SET 4 Digits New Master Code SET 4 Digits New Master Code SET

Step 4 Add New Permanent Entry Code

SET Master Code SET 02 SET Entry Code SET Entry Code SET

Step 5 Operate the Gate Opener

Input the entry code and then press button A (or B) to operate the gate. Within 3 seconds of pressing button A (or B), you can press the button again without re-entering the code to operate the gate.

NOTE: If the gate opener is ONLY solar powered, please add more solar panels and upgrade the battery capacity to support the additional power consumption by the wired keypad.

Connection of Accessories

TKP3 Wireless Keypad

Operate the gate with a user defined password

Programming and Operation

- ◆ Press and release the LEARN button on the control board. The LRN LED will turn on, indicating that the gate opener is now in programming mode.
- ◆ Press the button “OK” on the keypad and the LRN LED will flash for 3 seconds and then turn off, indicating successful programming.
- ◆ Use the default password “888888” to operate the gate opener. Press “PIN” “8 8 8 8 8 8” and then press the button “OK” to operate the opener. Just one press of the button “OK”, the moving gate will stop for quick passing through.

Change the Password

- ◆ Press “PIN”, input the old six digits password, and then press the “PIN” again, the LRN LED will be ON.
- ◆ Input the new six digits password and then press the “PIN” to confirm the new setting, LRN LED will flash for 3 seconds and then turn off which indicates the password has been changed successfully.
- ◆ Press “PIN” “new six digits password” and then press the button “OK” to operate the gate opener.



The keypad is circular with a grey face and a silver ring. It features a numeric keypad with buttons for digits 1-9, 0, and a PIN button. There are also buttons for 'OK' and 'LEARN'.

Program the Keypad

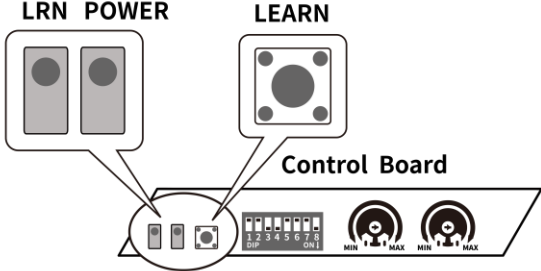

The diagram shows the control board with two callouts. The first callout points to the 'LRN POWER' section, which includes two indicator lights. The second callout points to the 'LEARN' button, which is a square button with a central circle and four smaller circles at the corners.

Use the Default Password

PIN 888888 OK

Change the Password

PIN Old Six Digits Password PIN
New Six Digits Password PIN

Use the New Password

PIN New Six Digits Password OK

NOTES:

- ◆ Each button press during programming must be completed within 1 second to ensure successful programming.
- ◆ If you forget the password, you can reset the keypad to restore the default code "888888" by reprogramming it.

Connection of Accessories

TC173 Wireless Push Button

Open / close the gate by pressing the wireless button

Programming and Operation

- ◆ Press and release the LEARN button on the control board. The LRN LED will turn on, indicating that the gate opener is now in programming mode.
- ◆ Press the push button once, then press it again after the LED on the push button turns off. The LRN LED will flash for 3 seconds and then turn off, indicating successful programming.
- ◆ Each press of the button will cycle the gate through open, stop, close, stop, and open.

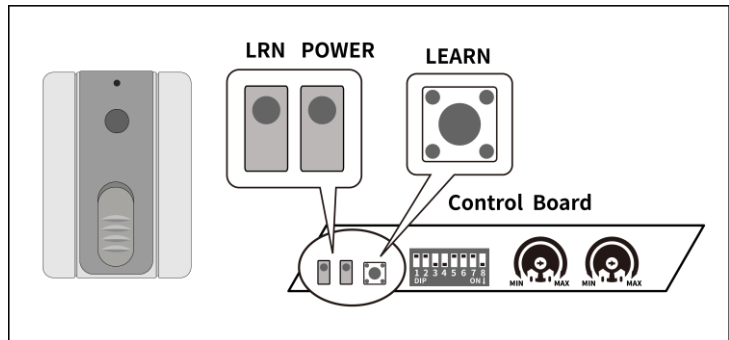

TC196 Tuya WiFi Remote Control

- ◆ Control the gate opener with your cellphone anytime and anywhere when the remote controller is connected with WiFi.
- ◆ Please see detailed connection steps in TC196 user manual.

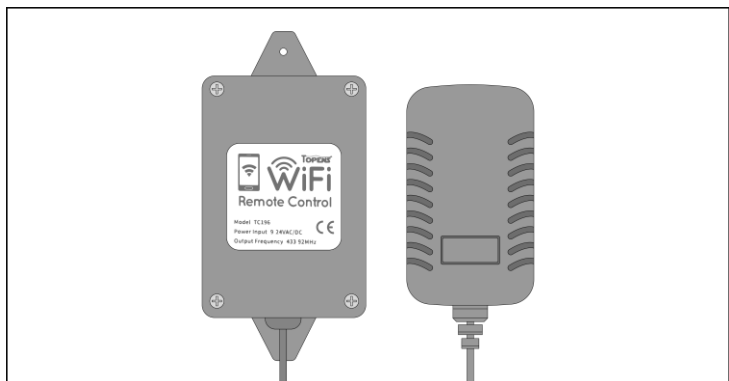

Connection of Accessories

TEW3 Vehicle Sensor Exit Wand

Opens the gate automatically when it senses an approaching car

Wire Connection

- ◆ Connect the BLACK and BLUE wires to control board terminals ⑭ and ⑮ “OPSW”, respectively.
- ◆ Connect the RED and GREEN wires to control board terminals ⑱ and ⑲ “+24VOUT-”, respectively.
- ◆ The sensitivity range adjustment board should be wired to the GREEN and YELLOW wires of the wand, regardless of the polarity.

Key Installation Notes

- ◆ Install the wand 7.5m to 30m (25ft. to 100ft.) away from the gate, and bury it 5cm (2") deep from ground and 20cm (8") from the driveway edge.
- ◆ Install the wand away from any power lines to avoid interrupting the detection signal.
- ◆ It is strongly recommended to enable the auto close function by referring to the Setting of the Control Board section in the installation manual to ensure home security.

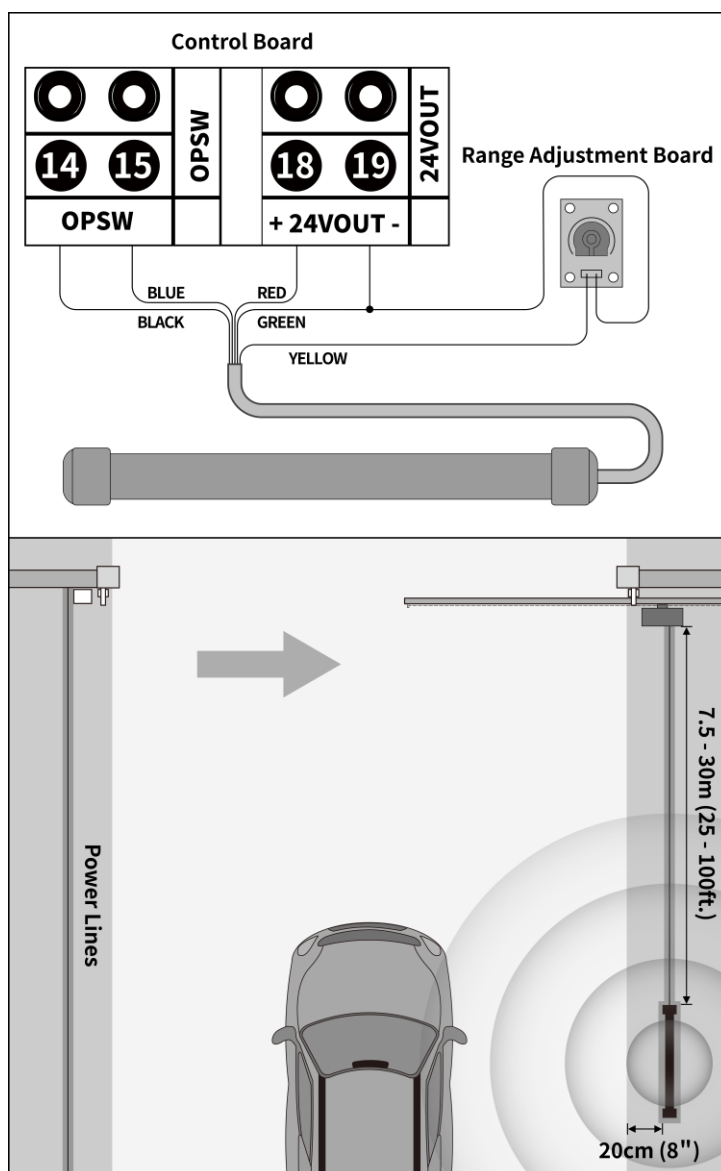

NOTE: If the gate opener is ONLY solar powered, please add more solar panels and upgrade the battery capacity to support the additional power consumption by the exit wand.

Connection of Accessories

TC175P Wired Keypad

Operate the gate with a user defined password / ID card

Wire Connection

- ◆ Connect the wires from the JP2 terminals of the wired keypad to the control board.
- ◆ Connect the BLUE wire to control board terminal ①⑥ “O/S/C” .
- ◆ Connect the PURPLE and BLACK wires to control board terminal ①⑦ “O/S/C” .
- ◆ Connect the RED wire to control board terminal ①⑧ “+24VOUT” .

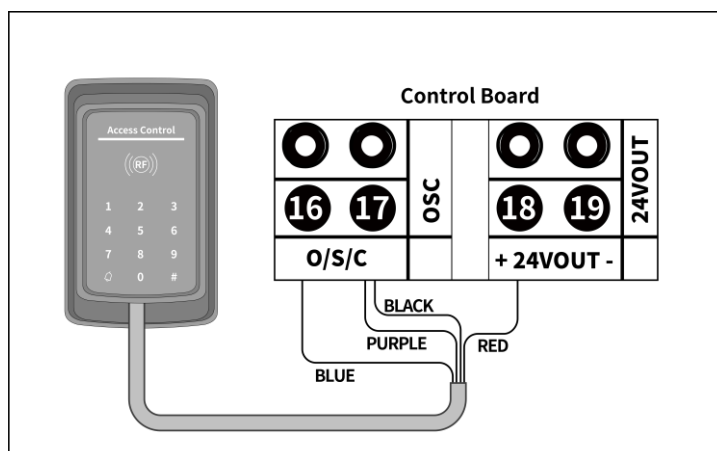

NOTES:

- ◆ A 4C x 0.3 mm² (22AWG) cable is required for the wire connection, but it is NOT included.
- ◆ Please see detailed password setting steps in TC175P user manual.
- ◆ If the gate opener is ONLY solar powered, please add more solar panels and upgrade the battery capacity to support the additional power consumption by the wired keypad.

HLR01 Homelink Remote Control Kit

Links the gate opener with your car's Homelink system, allows for easy control of the gate opener through the Homelink system.

Wire Connection

- ◆ Connect the ① and ② terminals to control board terminals ①⑥ and ①⑦ “O/S/C” , respectively.
- ◆ Connect the ⑦ and ⑧ “+DC-” terminals to control board terminals ①⑧ and ①⑨ “ +24VOUT- ” , respectively.

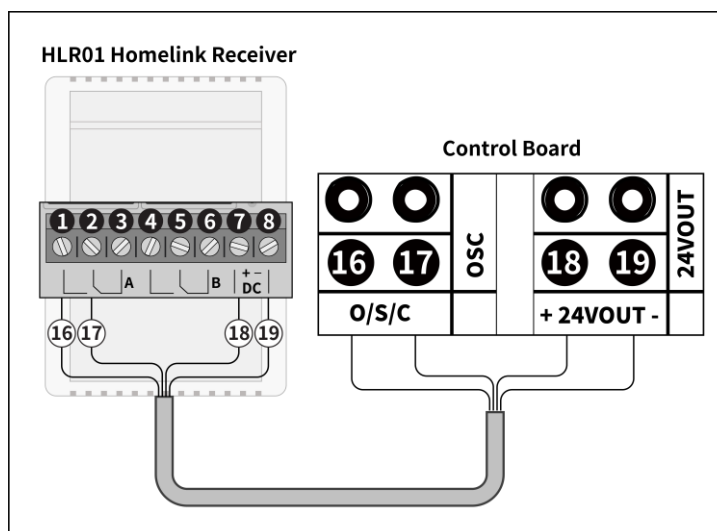

NOTES:

- ◆ A 4C x 0.3 mm² (22AWG) cable is required for the wire connection, but it is NOT included.
- ◆ Please see detailed programming steps with Homelink system in HLR01 user manual.
- ◆ If the gate opener is ONLY solar powered, please add more solar panels and upgrade the battery capacity to support the additional power consumption by the Homelink receiver.

Connection of Accessories

JD24VY Warning Light

Flashing when the gate is moving, improving your gate safety

Wire Connection

- ◆ Connect the BLACK and RED wires to control board terminals ⑥ and ⑦ “-LAMP+”, respectively.

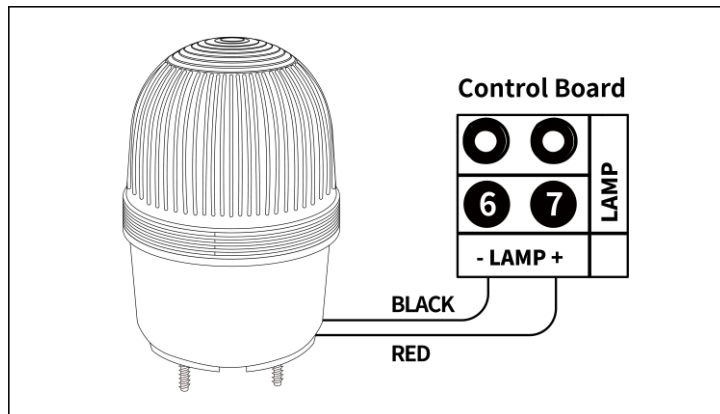

NOTE: A 2C x 0.3 mm² (22AWG) cable is required for the wire connection, but it is NOT included.

TRF3 Reflection Photocell Sensor

Prevents the gate from closing when obstructed, adds security with simple wire connection

Wire Connection

- ◆ Disconnect the jumper wire from terminals ⑫ and ⑬ “PHOTOCELL” on the control board to enable the photocell sensor function.
- ◆ Connect the “10-25VAC / 12-30VDC” terminals to control board terminals ⑱ and ⑲ “+24VOUT-”, regardless of the polarity.
- ◆ Connect the “COM” and “NC” terminals to control board terminals ⑫ and ⑬ “PHOTOCELL”, respectively.

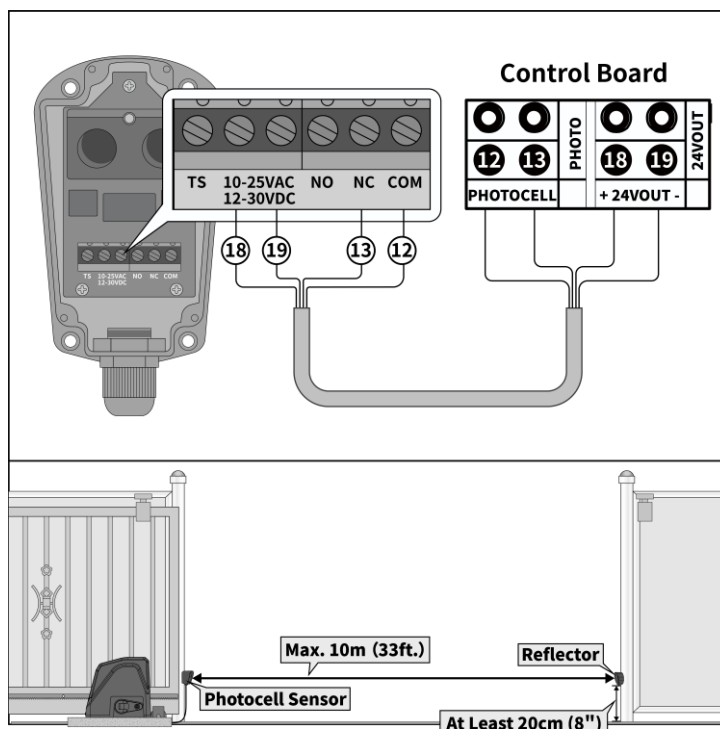

Key Installation Notes

- ◆ Mount the photocell sensor at least 20cm (8") above the ground.
- ◆ Power on the gate opener. Position the reflector directly opposite the mounted photocell sensor. The working light on the photocell sensor turning green indicates that the reflector is in the correct position.
- ◆ The maximum sensing range of the photocell sensor is 10m (33ft.).

NOTES:

- ◆ A 4C x 0.3 mm² (22AWG) cable is required for the wire connection, but it is NOT included.
- ◆ If the gate opener is ONLY solar powered, please add more solar panels and upgrade the battery capacity to support the additional power consumption by the photocell sensor.

Connection of Accessories

TC102 Infrared Photocell Sensor

Prevents the gate from closing when obstructed, adds security

Wire Connection

- ◆ Disconnect the jumper wire from terminals ⑫ and ⑬ “PHOTOCELL” on the control board to enable the photocell sensor function.
- ◆ For the emitter, connect the “~ +” and “~ -” terminals to control board terminals ⑱ and ⑲ “+24VOUT-”, respectively.
- ◆ For the receiver, connect the “~ +” and “~ -” terminals to control board terminals ⑱ and ⑲ “+24VOUT-”, respectively. Connect the “COM” and “NC” terminals to control board terminals ⑫ and ⑬ “PHOTOCELL”, respectively.

Key Installation Notes

- ◆ Mount the photocell sensor at least 20cm (8") above the ground.
- ◆ Place the receiver on the control box side of the gate opener, directly facing the emitter.
- ◆ Ensure that both the emitter and receiver are aligned with each other. If manual precise alignment is difficult, use a visible laser beam for assistance.
- ◆ The maximum sensing range is 20m (65ft.), and the recommended distance between the emitter and receiver is 3m to 14m (10ft. to 46ft.).
- ◆ Put the cables into PVC conduit and bury the conduit underground to prevent damage.

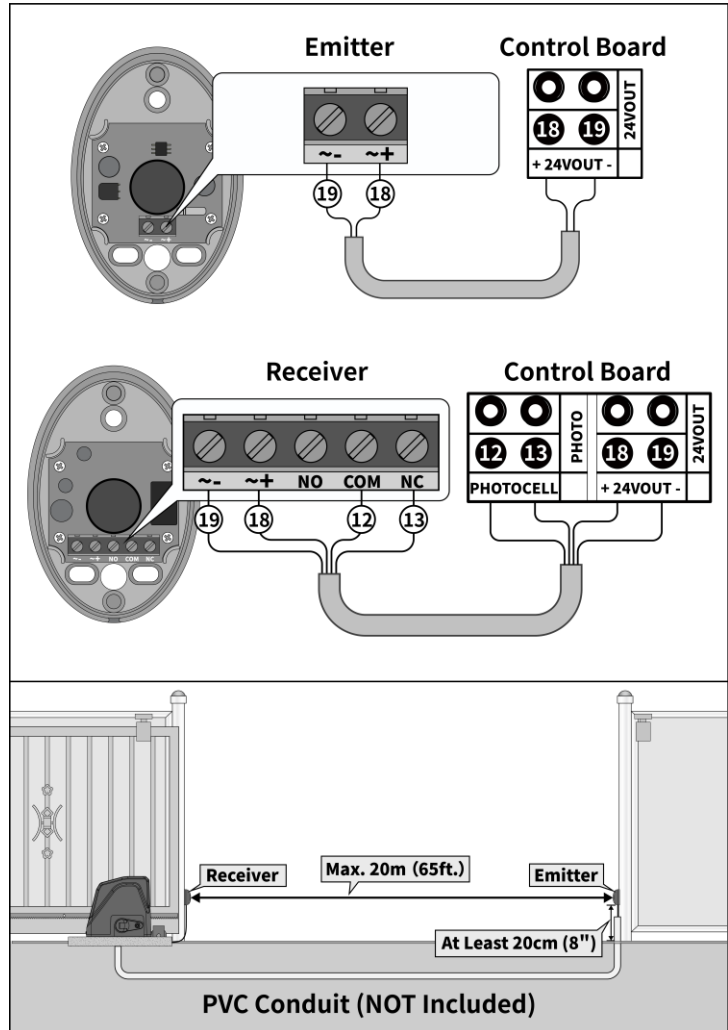

NOTES:

- ◆ Connect the emitter to the gate opener with a 2C x 0.3 mm² (22AWG) cable. Connect the receiver to the gate opener with a 4C x 0.3 mm² (22AWG) cable. Cables are required but NOT included.
- ◆ If the gate opener is ONLY solar powered, please add more solar panels and upgrade the battery capacity to support the additional power consumption by the photocell sensor.

Connection of Accessories

ERM12 External Receiver

Allows up to 250 remotes to be programmed with the gate opener

Wire Connection

- ◆ Connect the BROWN and BLACK wires to control board terminals ①⑥ and ①⑦ “O/S/C” , respectively.
- ◆ Connect the RED wire to control board terminal ①⑧ “+24VOUT” .

Program the Remote Control with the Receiver

- ◆ Before programming, ensure the M12 remote control has been erased from the control board to avoid conflicts.
- ◆ Press and release the Learn Button on the receiver, the LED light will turn ON. Press the remote control button you want to program once, then press it again after the LED on the remote turns off.
- ◆ The LED Light on the receiver will flash for 3 seconds and then turn OFF indicating successfully programming.

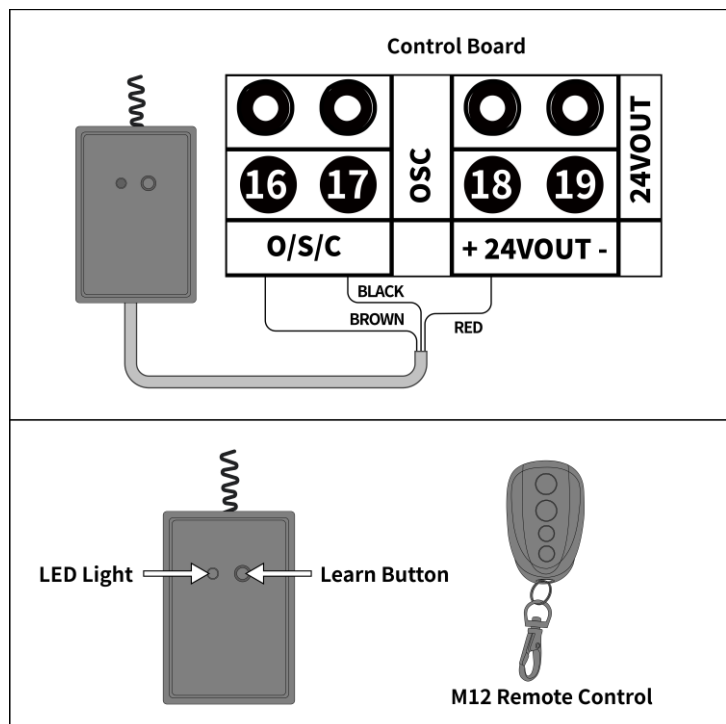

NOTE: If the gate opener is ONLY solar powered, please add more solar panels and upgrade the battery capacity to support the additional power consumption by the receiver.

TC148 Waterproof Wall Push Button & TC147 Wall Push Button

Open / close the gate by pressing the wired button

Wire Connection

- ◆ Connect the push button to control board terminals ①⑥ and ①⑦ “O/S/C” , regardless of the polarity.
- ◆ Each press of the button will cycle the gate through open, stop, close, stop, and open.

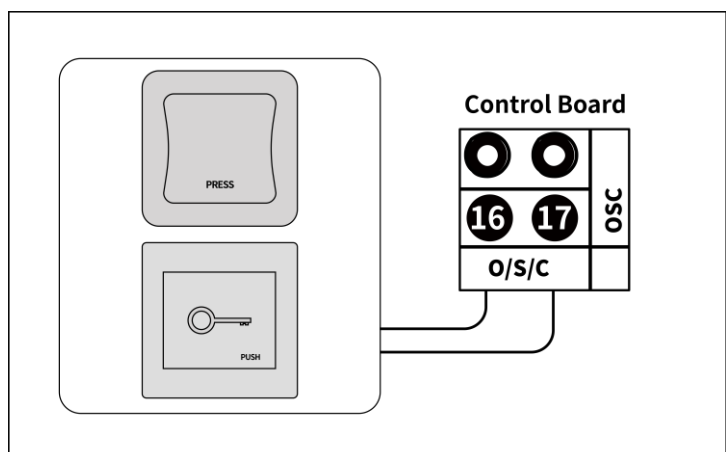

NOTE: A 2C x 0.3 mm² (22AWG) cable is required for the wire connection, but it is NOT included.

Maintenance and Replacement Parts

Maintenance

WARNING

Disconnect all power (AC and battery) to the gate opener before routine inspections and lubrication.

Routine Inspections

- ◆ **Inspect the Gate:** Look for any signs of wear or damage on the gate and guide tracks.
- ◆ **Check the Gate Opener:** Ensure that the opener is securely attached to the concrete pad. Tighten any loose bolts and screws.
- ◆ **Examine Cables and Wires:** Check that all cables and wires are intact and free from corrosion. Ensure that the opener is properly earthed and the wire is securely connected.

Cleaning and Lubrication

Keep the gate opener and the surrounding area clean to prevent the accumulation of dirt, dust, leaves, and debris. Use a clean, dry cloth to wipe the gate opener shafts and gears, and lubricate them as needed.

Battery Maintenance

Regularly check for battery leakage and ensure that its casing is intact. Monitor the battery voltage through the solar controller or control board. Replace the battery every 2-3 years and recycle old batteries properly.

Obstruction Test

The gate must stop or reverse upon contact with a solid object. Perform the obstruction test monthly, or whenever you set up the control board or after a power outage. Failure to properly adjust and retest the gate opener can increase the risk of injury or death.

Replacement Parts

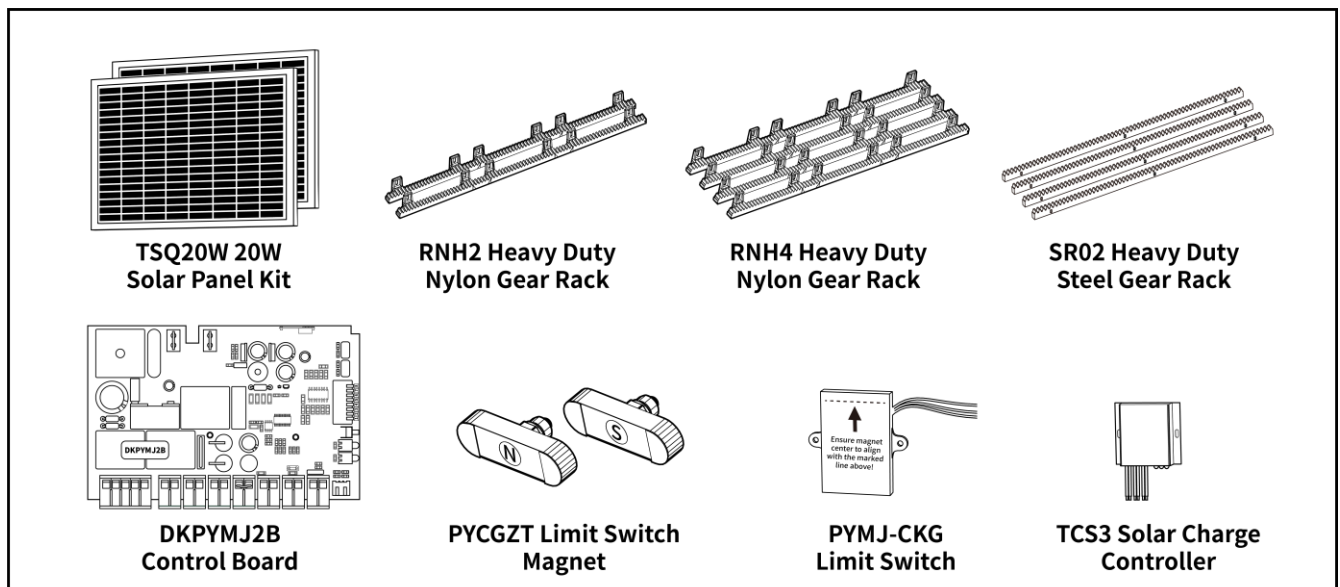

* Available on the TOPENS website (www.topens.com) and Amazon.

Troubleshooting

If your gate opener does not function properly after installation, please follow the steps below before contacting us for assistance. This guide provides common troubleshooting steps to help resolve issues efficiently. For further assistance, please feel free to contact us through our website at www.topens.com.

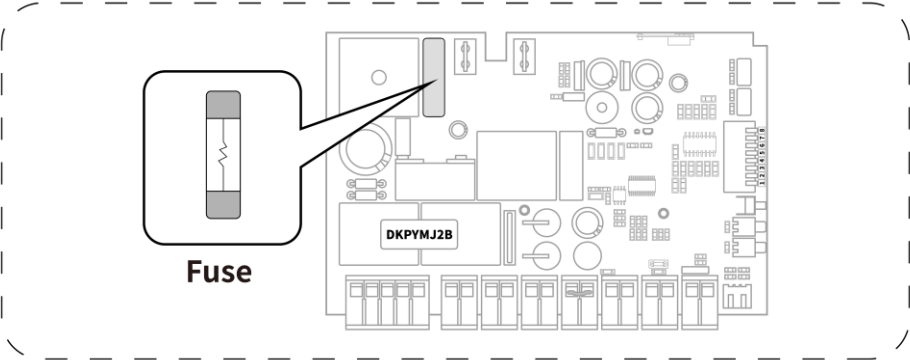
Symptom	Possible Solution(s)
<p>The opener does not run. Power LED is OFF.</p>	<p>Step 1 Check Power Supply and Transformer Output (for the AC-Powered opener):</p> <ul style="list-style-type: none"> ◆ Ensure that the power supply is connected properly and securely. ◆ Verify that the output voltage of the transformer is 24VAC. If the voltage is 0, the transformer may be overheated or damaged. Turn off the power, allow the board to cool for several minutes, then reset. Replace the transformer if the issue persists. <p>Step 2 Examine Control Board Fuse: Inspect the control board fuse and replace it with the backup fuse that comes with the gate opener if it is burnt out. The fuse type is Ø5*20mm 10A 250VAC fast blow glass fuse.</p> <div style="text-align: center;">  </div> <p>Step 3 Observe Solar Controller and Check Battery Voltage (for the Battery-Powered Opener):</p> <ul style="list-style-type: none"> ◆ For the opener powered by battery with a solar controller: if the LOAD LED on the solar controller is OFF and the battery voltage is below 23VDC, wait until the batteries are fully charged. If the LED is OFF and the battery voltage is above 23VDC (normal), the solar controller may be faulty. ◆ For the opener solely powered by battery and AC electricity, check the battery voltage directly to ensure it is above 23VDC. If it is not, wait until the batteries are fully charged. <p>Step 4 Check Control Board: Inspect the control board and replace it if needed.</p>

Troubleshooting

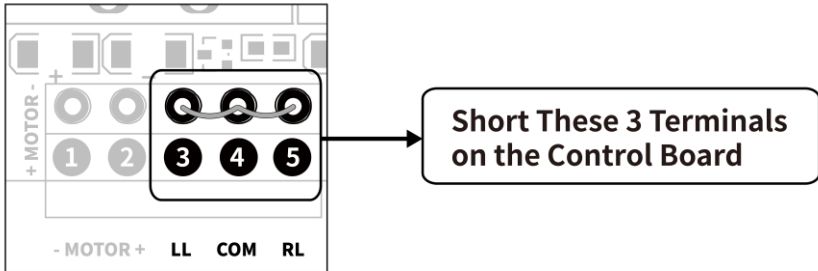
Symptom	Possible Solution(s)
<p>The opener does not run. Power LED is ON.</p>	<p>Step 1 Check Remote Control: Ensure the remote control is functioning properly. Confirm that the indicator light is ON, the remote is within the effective control range (<65 feet), and it is programmed with the opener.</p> <p>Step 2 Check Photocell Sensor Function: If a photocell sensor is used as a secondary entrapment prevention device, ensure its beam is not blocked. If no photocell sensor is installed, short the “PHOTOCELL” terminal on the control board with a jumper wire.</p> <p>Step 3 Test the Motor: Disengage the clutch and disconnect the motor wires from terminals 1 and 2. Connect the wires directly to a 24V battery. The motor should run. Reverse the wire connections to the battery, and the motor should run in the opposite direction. If the motor operates in both directions, proceed to check the other components.</p> <p>Step 4 Verify Magnet Position: Disengage the clutch and manually move the gate to the middle position. Re-engage the clutch and operate the gate. If the gate moves correctly but does not run when starting from the fully open / closed position, adjust the magnet to the correct position as instructed in the manual.</p> <p>Step 5 Check Limit Switch: Use two jumper wires to simultaneously short terminals 3, 4, and 5. Press the remote to operate the opener. If the motor runs normally in both directions, replace the limit switch.</p> <div data-bbox="523 1265 1433 1601" style="border: 1px dashed gray; padding: 10px; margin: 10px 0;"> <p style="text-align: center;">Control Board</p>  </div> <p>Step 6 Check Control Board: Inspect the control board and replace it if needed.</p>

Troubleshooting

Symptom	Possible Solution(s)
<p>The gate starts but immediately stops or reverses.</p>	<p>Step 1 Check HALL Sensor: Verify that the HALL sensor board on the side of the gearbox is securely connected to the control board.</p> <p>Step 2 Check the Clutch: Confirm that the clutch is properly engaged and not slipping.</p> <p>Step 3 Adjust Stall Force: Ensure that the open or close stall force is appropriate and not too low. Adjust Potentiometer A and B to increase the force.</p> <p>Step 4 Check for Free Sliding: Disconnect the gate from the opener and ensure that it slides freely without any obstruction.</p> <p>Step 5 Check Control Board: Inspect the control board and replace it if needed.</p>
<p>The gate opens but stops and will not return.</p>	<p>Step 1 Confirm Magnet Installation: Ensure that the N magnet is positioned on the left side and the S magnet on the right side when viewed from inside the property.</p> <p>Step 2 Swap Limit Switch Wires: Exchange the limit switch wires CL (close) and OP (open) on the control board.</p> <p>Step 3 Verify Magnet Position: Check if the magnet has been installed incorrectly. Adjust the magnet to the correct position as instructed in the manual.</p> <p>Step 4 Check Control Board: Inspect the control board and replace it if needed.</p>
<p>The gate opens but fails to close.</p>	<p>Step 1 Verify Photocell Sensor Function: Check if the wire jumper is missing, or if the photocell sensor is blocked or misaligned. Reconnect the terminals, clear any obstructions, and ensure that the photocell sensor is properly aligned.</p> <p>Step 2 Check Limit Switch: Use two jumper wires to simultaneously short terminals 3, 4, and 5 (refer to the same illustration of troubleshooting step as before). Press the remote to operate the opener. If the motor runs normally in both directions, replace the limit switch.</p> <p>Step 3 Check Control Board: Inspect the control board and replace it if needed.</p>

Troubleshooting

Symptom	Possible Solution(s)
The gate opens randomly.	<p>Step 1 Check DIP Switch Setting: Set DIP Switch #8 to ON for a left-opening gate and OFF for a right-opening gate.</p> <p>Step 2 Isolate the Issue with Wired Accessories: Disconnect all wired accessories from the control board and disable the photocell sensor function by shorting the “PHOTOCELL” terminal on the control board with a jumper wire. Test the gate operation. If the issue is resolved, reconnect the accessories one by one to identify the problem.</p> <p>Step 3 Reprogram Remote Controls: Clear all existing remote codes from the control board and reprogram the remote controls.</p> <p>Step 4 Check Control Board: Inspect the control board and replace it if needed.</p>
Midway mode function is disabled.	<p>Step 1 Check DIP Switch Setting: Set DIP Switch #8 to ON for a left-opening gate and OFF for a right-opening gate.</p> <p>Step 2 Verify Magnet Position: Check if the limit switch is properly sensed by the closing magnet when the gate is fully closed. Adjust the magnet's position to ensure accurate sensing.</p> <p>Step 3 Replace Remote Control: Use a new remote control and test again.</p> <p>Step 4 Check Control Board: Inspect the control board and replace it if needed.</p>
Soft stop function is abnormal.	<p>Step 1 Turn Off Power to the Gate Opener and Restart: If you have used the release key to manually open the gate or reset the soft stop period, turn off the power to the gate opener and restart it. Then, use the remote control to run a complete open and close cycle to calibrate the full open and close times.</p> <p>Step 2 Check Limit Switch: Verify that the limit switch functions correctly and stops the gate as needed. If it works abnormally, adjust the magnet to the correct position as instructed in the manual.</p> <p>Step 3 Extend Soft Stop Period: If gate inertia is high during opening and closing, increase the soft stop period.</p> <p>Step 4 Check Control Board: Inspect the control board and replace it if needed.</p>



T: 0086-27-8700 1865
E-mail: agc.wuhan@agc-cert.com
Web: Http://www.agc-cert.com

Room 102, 1st-2nd floor of Building 3, Wuhan Jinneng
Windpower Industrial Park, No.9 Zhulin Road, Fozuling
Street, Wuhan East Lake High-tech Development Zone,
China

Attestation of Conformity

Applicant Hangzhou Sanford Technology Co., Ltd
Room 106, Building 4, 8 Shengdi Road, Yuhang Town, Hangzhou City, Zhejiang Province,
China

Product Designation Sliding gate opener

Brand Name /

Model / Series Models DKR500, DKR1100, DSR500, DSR1100

Manufacturer Hangzhou Sanford Technology Co., Ltd
Room 106, Building 4, 8 Shengdi Road, Yuhang Town, Hangzhou City, Zhejiang Province,
China

Requirement	Applied Standards	Document Evidence	Result
EMC Directive	EN 55014-1:2017+A11:2020 EN 55014-2:2015 EN IEC 61000-3-2:2019 EN 61000-3-3:2013+A1:2019	Test Report: AGC-WH00066210440EE01	Conform



Bram Wu
Signed by General Manager(Bram Wu)
Issue Date: August 3, 2021

This Attestation of Conformity is recognized by Attestation of Global Compliance (Wuhan) Co., Ltd. and made in accordance with the Electromagnetic Compatibility (EMC) Directive 2014/30/EU. The attestation doesn't imply assessment of the production. The Applicant of the attestation is authorized to use this attestation in connection with EC declaration of conformity to the Directive. The attestation is only applicable to the equipments described above. This attestation shall not be re-produced except in full without the written approval of Attestation of Global Compliance (Wuhan) Co., Ltd.

Note: This attestation is part of the full test report(s) and should be used in conjunction with it.

Version: 1.0



T: 0086-27-8700 1865
E-mail: agc.wuhan@agc-cert.com
Web: Http://www.agc-cert.com

Room 102, 1st-2nd floor of Building 3, Wuhan Jinneng
Windpower Industrial Park, No.9 Zhulin Road, Fozuling
Street, Wuhan East Lake High-tech Development Zone,
China

Attestation of Conformity

Applicant Hangzhou Sanford Technology Co., Ltd.
Room 106, Building 4, 8 Shengdi Road, Yuhang Town, Hangzhou City, Zhejiang Province, China

Product Designation Sliding gate opener

Brand Name /

Model / Series Models DSR1100,DSR500, DKR500, DKR1100

Manufacturer Hangzhou Sanford Technology Co., Ltd.
Room 106, Building 4, 8 Shengdi Road, Yuhang Town, Hangzhou City, Zhejiang Province, China

Requirement	Applied Standards	Document Evidence	Result
LVD Directive	EN 60335-2-103:2015, EN 60335-1:2012 +A11:2014+A13:2017, EN 62233:2008	Test Report: AGC-WH00066210440ES01	Conform



Signed by General Manager(Bram Wu)

Issue Date: August 3, 2021



This Attestation of Conformity is recognized by Attestation of Global Compliance (Wuhan) Co., Ltd. and made in accordance with the Low Voltage Directive 2014/35/EU. The attestation doesn't imply assessment of the production. The Applicant of the attestation is authorized to use this attestation in connection with EC declaration of conformity to the Directive. The attestation is only applicable to the equipments described above. This attestation shall not be re-produced except in full without the written approval of Attestation of Global Compliance (Wuhan) Co., Ltd.

Note: This attestation is part of the full test report(s) and should be used in conjunction with it.

Version: 1.0



T: 0086-27-8700 1865
E-mail: agc.wuhan@agc-cert.com
Web: Http://www.agc-cert.com

Room 102, 1st-2nd floor of Building 3, Wuhan Jinneng
Windpower Industrial Park, No.9 Zhulin Road, Fozuling
Street, Wuhan East Lake High-tech Development Zone,
China

Attestation of Conformity

Applicant Hangzhou Sanford Technology Co., Ltd
Room 106, Building 4, 8 Shengdi Road, Yuhang Town, Hangzhou City, Zhejiang Province, China

Product Designation Sliding gate opener

Brand Name /

Model / Series Models DKR500, DKR1100, DSR500, DSR11000

Manufacturer Hangzhou Sanford Technology Co., Ltd
Room 106, Building 4, 8 Shengdi Road, Yuhang Town, Hangzhou City, Zhejiang Province, China

Requirement	Applied Standards	Document Evidence	Result
Electromagnetic Compatibility Regulations 2016	BS EN 55014-1:2017+A11:2020 BS EN 55014-2:2015 BS EN IEC 61000-3-2:2019 BS EN 61000-3-3:2013+A1:2019	Test Report: AGC-WH00066210440EE02	Conform



Bram Wu
Signed by General Manager(Bram Wu)
Issue Date: June 22, 2021

Recognized by Attestation of Global Compliance (Wuhan) Co., Ltd. in accordance with the Electromagnetic Compatibility Regulations 2016. The attestation doesn't imply assessment of the production. The applicant of the attestation is authorized to use this attestation in connection with UK declaration of conformity to the regulation. The attestation is only applicable to the equipment described above. This attestation shall not be re-produced without the written approval of Attestation of Global Compliance (Wuhan) Co., Ltd.

Note: This attestation is part of the full test report(s) and should be used in conjunction with it.

Version: 1.0



T: 0086-27-8700 1865
E-mail: agc.wuhan@agc-cert.com
Web: Http://www.agc-cert.com

Room 102, 1st-2nd floor of Building 3, Wuhan Jinneng
Windpower Industrial Park, No.9 Zhulin Road, Fozuling
Street, Wuhan East Lake High-tech Development Zone,
China

Attestation of Conformity

Applicant Hangzhou Sanford Technology Co., Ltd.
Room 106, Building 4, 8 Shengdi Road, Yuhang Town, Hangzhou City, Zhejiang Province, China

Product Designation Sliding gate opener

Brand Name /

Model / Series Models DSR1100, DSR500, DKR500, DKR1100

Manufacturer Hangzhou Sanford Technology Co., Ltd.
Room 106, Building 4, 8 Shengdi Road, Yuhang Town, Hangzhou City, Zhejiang Province, China

Requirement	Applied Standards	Document Evidence	Result
Electrical Equipment (Safety) Regulations 2016	BS EN 60335-2-103:2015, BS EN 60335-1:2012+ A11:2014+A13:2017, BS EN 62233:2008	Test Report: AGC-WH00066210440BS02	Conform



Signed by General Manager (Bram Wu)

Issue Date: June 22, 2021

Recognized by Attestation of Global Compliance (Wuhan) Co., Ltd. in accordance with the Electrical Equipment (Safety) Regulations 2016. The attestation doesn't imply assessment of the production. The applicant of the attestation is authorized to use this attestation in connection with UK declaration of conformity to the regulation. The attestation is only applicable to the equipment described above. This attestation shall not be re-produced without the written approval of Attestation of Global Compliance (Wuhan) Co., Ltd.
Note: This attestation is part of the full test report(s) and should be used in conjunction with it. Version: 1.0

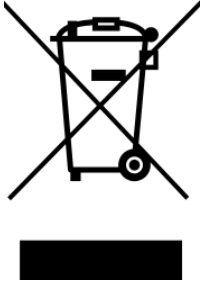

According to Waste of Electrical and Electronic Equipment (WEEE) directive, WEEE should be separately collected and treated. If at any time in future you need to dispose of this product, please do NOT dispose of this product with household waste. Please send this product to WEEE collecting points where available.

Feedback & Review

Your comments and suggestions are important to us
as they help us provide the best possible service.

Should you have any need to contact us, the info below will help you get in touch:



TOPENS Website

www.topens.com

Contact Us:

E-mail: support@topens.com

Kindly include your purchase channel, order #, gate information, issue description and your contact information. All your concerns will be replied within 24 hours.

Tel: +1 (888) 750 9899 (Toll Free USA & Canada)