

SOPHIA

SPLIT AIR CONDITIONER WITH HEAT PUMP

USER'S MANUAL

Models:

CH-SR09SPH-115VI/CH-SR09SPH-115VO (115V)

CH-09SPH-115VI/CH-09SPH-115VO (115V)

CH-12SPH-115VI/CH-12SPH-115VO (115V)

CH-09SPH-230VI/CH-09SPH-230VO (230V)

CH-12SPH-230VI/CH-12SPH-230VO (230V)

CH-18SPH-230VI/CH-18SPH-230VO (230V)

CH-24SPH-230VI/CH-24SPH-230VO (230V)

CH-30SPH-230VI/CH-30SPH-230VO (230V)

CH-36SPH-230VI/CH-36SPH-230VO (230V)

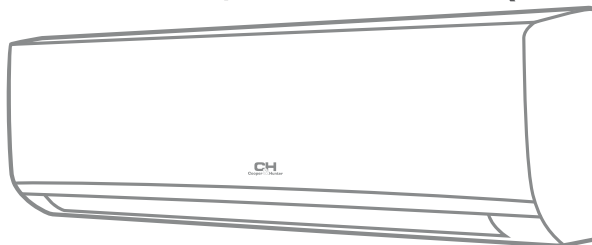

IMPORTANT NOTE:

Read this manual carefully before installing or operating your new air conditioning unit. Be sure to save this manual for future reference.



WARNING

Operation and Maintenance

- This appliance can be used by children ages 8 years and above and persons with reduced physical, sensory, or mental capabilities or lack of experience and knowledge. Ensure that they have been given supervision or instruction concerning use of the appliance in a safe way and understand the hazards involved.
- Children should not play with the appliance.
- Cleaning and user maintenance should not be made by children without supervision.
- Do not connect the air conditioner to a multi-purpose socket. This may cause a fire.
- Do not disconnect the power supply when cleaning the air conditioner. This may cause electric shock.
- If the supply cord is damaged, it must be replaced by the manufacturer, its service agent, or similarly qualified persons to avoid a hazard.
- Do not wash the air conditioner with water. This may cause electric shock.
- Do not spray water on the indoor unit. This may cause electric shock or malfunction.
- To avoid injury, do not touch the fins after removing the filter.
- To avoid deformation or fire, do not use fire or a hair dryer to dry the filter.



WARNING

- To avoid personal injury or damage, only allow qualified professionals to perform maintenance.
- Please contact your dealer when you need to repair your air conditioner; do not repair it by yourself. This may cause electric shock or damage.
- Do not extend your fingers or objects into the air inlet or air outlet. This may cause personal injury or damage.
- Do not block the air inlet or air outlet. This may cause malfunction.
- Spilling water on the remote control may ruin it.
- When below phenomena occur, please turn of the air conditioner, disconnect the power immediately, and contact the dealer or qualified professionals for service:
 - The power cord is overheating or damaged
 - An abnormal sound is heard during operation
 - The circuit break trips off frequently
 - The air conditioner produces a burning smell
 - The indoor unit is leaking
- If the air conditioner operates under abnormal conditions, malfunction, electric shock, or fire may result.
- When turning on or turning off the unit by emergency operation switch, please press this switch with an insulating object other than metal.
- Do not step on the top panel of the outdoor unit or place heavy objects on it. This may cause personal injury or damage.



WARNING

Attachment

- To avoid personal injury or damage, allow installation to be performed by qualified professionals.
- Qualified professionals should follow the electric safety regulations when installing the unit.
- In accordance with local safety regulations, use a qualified power supply circuit and circuit break.
- To avoid malfunction, install the circuit break.
- An all-pole disconnection switch with a contact separation of at least 1/8 in (3 mm) in all poles should be connected in fixed wiring.
- Include an air switch with suitable capacity. The air switch should include a magnet buckle and heating buckle function to protect the unit from circuit-short and overload.
- The air conditioner should be properly grounded. Incorrect grounding may cause electric shock.
- Don't use an unqualified power cord.
- Make sure the power supply matches the requirement of the air conditioner. Unstable power supply may cause a malfunction. Please install the proper power supply cables before using the air conditioner.
- Please connect the live wire, neutral wire, and grounding wire of the power socket.
- Be sure to cut off the power supply before performing any work related to electricity and safety.



WARNING

- Do not add power before finishing installation.
- If the supply cord is damaged, it must be replaced by the manufacturer, the service agent, or similarly qualified persons for a hazard to be avoided.
- Because the temperature of the refrigerant circuit will be high, ensure that the interconnection cable is kept away from the copper tube.
- The appliance should be installed in accordance with national wiring regulations.
- Installation must be performed by authorized personnel only in accordance with the requirements of National Electrical Codes (NEC) and local electrical codes.
- The air conditioner is a first-class electrical appliance. It must be properly grounded by a professional with a specialized grounding device. To avoid electric shock, ensure that it is grounded effectively.
- The yellow-green wire in the air conditioner is the grounding wire and cannot be used for other purposes.
- The grounding resistance should comply with National Electric Safety regulations.
- The appliance must be positioned so that the plug is accessible.
- All wires of both the indoor unit and the outdoor unit should be connected by a professional.
- If the length of power connection wire is insufficient, please contact the supplier for a new one. Avoid extending the wire by yourself.



WARNING

- For the air conditioner model with a plug, the plug should be reachable after installation is complete.
- For the air conditioner model without a plug, a circuit break must be installed in the line.
- Only a qualified professional should relocate the air conditioner. Personal injury or damage may result if you try to move it yourself.
- Select a location that is out of reach of children and far away from animals or plants. If this is impossible, please add a fence for safety purposes.
- The indoor unit should be installed close to a wall.
- Instructions for installation and use of this product are provided by the manufacturer.



WARNING

This symbol indicates that ignoring instructions may cause death or serious injury.



CAUTION

This symbol indicates that ignoring instructions may cause moderate injury to your person or damage to your unit or other property.



This symbol indicates that you must never perform the action indicated.

Unit Specifications and Features

1

Unit Parts

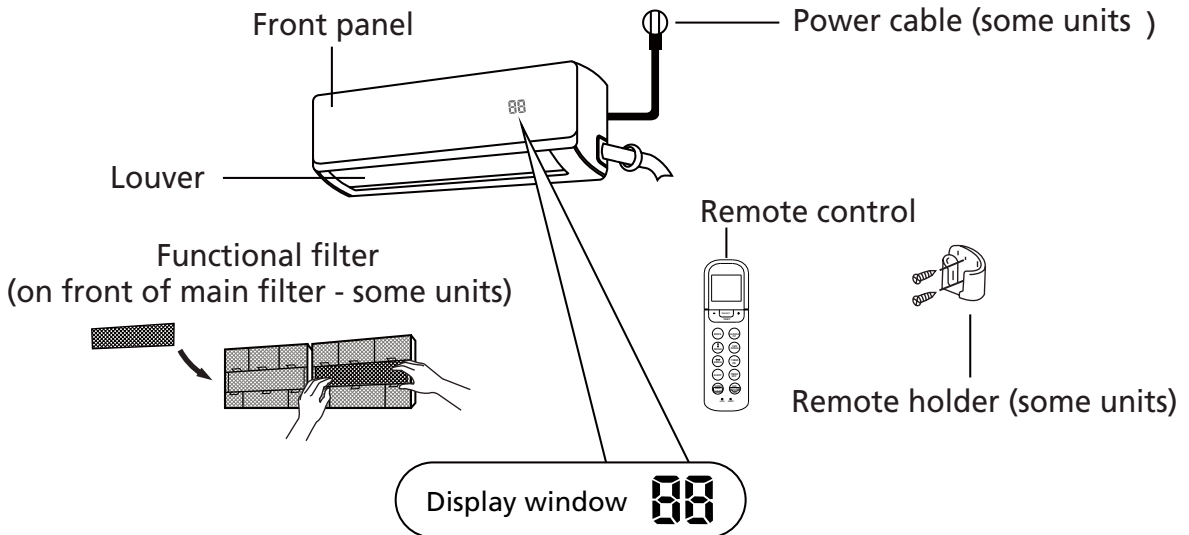

- "**ON**" for 3 seconds when:
- **TIMER ON** is set
 - **FRESH, SWING, TURBO, or SILENCE** features are turned on
- "**OF**" for 3 seconds when:
- **TIMER OFF** is set
 - **FRESH, SWING, TURBO, or SILENCE** features are turned off
- "**cF**" when anti-cold air feature is turned on
- "**dF**" when unit is defrosting
- "**SC**" when unit is self-cleaning
- "**FP**" when freeze protection is turned on
- "**88**" when the Eco function (optional) is activated, the '88' illuminates one by one as ξ --
 ξ -- ξ --set temperature -- ξ in one second intervals.

NOTE: A guide on using the infrared remote is not included in this literature package.

In **FAN** mode, the unit will display the room temperature.

In other modes, the unit will display your temperature setting.

Display Code Meanings

Achieving Optimal Performance

Optimal performance for the COOL, HEAT, and DRY modes can be achieved in the following temperature ranges. When your air conditioner is used outside of these ranges, certain safety protection features will activate and cause the unit to perform less than optimally.

Inverter Split Type

	COOL mode	HEAT mode	DRY mode
Room Temperature	63°F - 90°F (17°C - 32°C)	32°F - 86°F (0°C - 30°C)	50°F - 90°F (10°C - 32°C)
Outdoor Temperature	32°F - 122°F (0°C - 50°C)	5°F - 86°F (-15°C - 30°C)	32°F - 122°F (0°C - 50°C)
	5°F - 122°F (-15°C - 50°C) (For models with low temp. cooling systems)		

FOR UNITS WITH AUXILIARY ELECTRIC HEATER

When the outside temperature is below 0°C (32°F), we strongly recommend keeping the unit plugged in at all times to ensure smooth ongoing performance.

Fixed-Speed Type

	COOL mode	HEAT mode	DRY mode
Room Temperature	63°-90°F (17°-32°C)	32°-86°F (0°-30°C)	50°-90°F (10°-32°C)
Outdoor Temperature	64°-109°F (18°-43°C)	19°-75°F (-7°-24°C)	52°-109°F (11°-43°C)
	19°-109°F (-7°-43°C) (For models with low-temp cooling systems)		64°-109°F (18°-43°C)
	64°-126°F (18°-52°C) (For special tropical models)		64°-126°F (18°-52°C) (For special tropical models)

To further optimize the performance of your unit, do the following:

- Keep doors and windows closed.
- Limit energy usage by using the TIMER ON and TIMER OFF functions.
- Do not block air inlets or outlets.
- Regularly inspect and clean the air filters.

For a detailed explanation of each function, refer to the **Remote Control Manual**.

Other Features

- **Auto-Restart**
If the unit loses power, it will automatically restart with the prior settings once power has been restored.
- **Anti-mildew (some units)**
When turning off the unit from COOL, AUTO (COOL), or DRY modes, the air conditioner will continue to operate at very low power to dry up condensed water and prevent mildew growth.
- **Wi-Fi Control (some units)**
Wi-Fi control allows you to control your air conditioner using your mobile phone and a Wi-Fi connection.
- **Louver Angle Memory (some units)**
When turning on your unit, the louver will automatically resume its former angle.
- **Refrigerant Leakage Detection (some units)**
The indoor unit will automatically display “EC” when it detects refrigerant leakage.

For a detailed explanation of your unit's advanced functionality (such as TURBO mode and the self-cleaning functions), refer to the **Remote Control Manual**.

NOTE ON ILLUSTRATIONS

Illustrations in this manual are for explanatory purposes. The actual shape of your indoor unit may be slightly different. The actual shape prevails.

• Setting Angle of Airflow

Setting the Vertical Angle of Airflow

While the unit is on, use the **SWING/DIRECT** button to set the direction (vertical angle) of airflow.

1. Press the **SWING/DIRECT** button once to activate the louver. Each time you press the button, it will adjust the louver by 6°. Press the button until the direction you prefer is reached.
2. To make the louver swing up and down continuously, press and hold the **SWING/DIRECT** button for 3 seconds. Press it again to stop the automatic function.

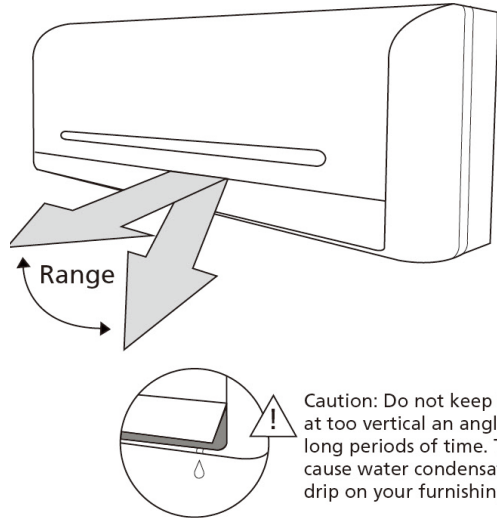

Caution: Do not keep the louver at too vertical an angle for long periods of time. This can cause water condensation to drip on your furnishings.

Fig. 2.2

Setting the Horizontal Angle of Airflow

The horizontal angle of the airflow must be set manually. Grip the deflector rod (See **Fig. 2.3**) and manually adjust it to your preferred direction. For some units, the horizontal angle of the airflow can be set by remote control. Please refer to the Remote Control Manual.

NOTE ON LOUVER ANGLES

When using COOL or DRY mode, do not set the louver at too vertical an angle for long periods of time. This can cause water to condense on the louver blade, which will drop on your floor or furnishings. (See **Fig. 2.2**)

When using COOL or HEAT mode, setting the louver at too vertical an angle can reduce the performance of the unit due to restricted airflow.

Do not move the louver by hand. This will cause the louver to become out of sync. If this occurs, turn off the unit and unplug it for a few seconds, then restart the unit. This will reset the louver.

! CAUTION

Do not put your fingers in or near the blower and suction side of the unit. The high-speed fan inside the unit may cause injury.

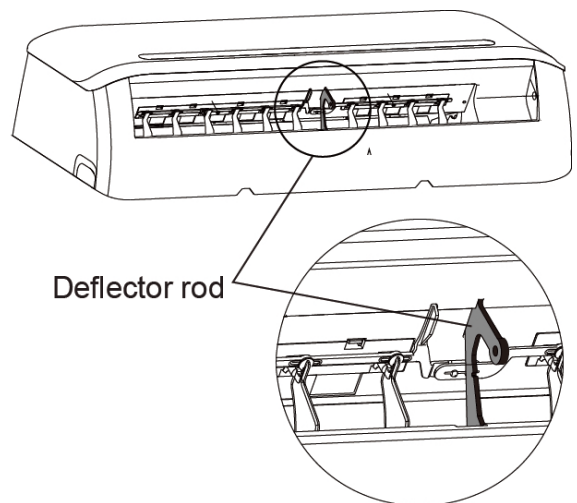

Fig. 2.3

• Sleep Operation

The SLEEP function is used to decrease energy use while you sleep (and don't need the same temperature settings to stay comfortable). This function can only be activated via remote control.

Press the **SLEEP** button when you are ready to go to sleep. When in COOL mode, the unit will increase the temperature by 2°F (1°C) after 1 hour, and will increase an additional 2°F (1°C) after another hour. When in HEAT mode, the unit will decrease the temperature by 2°F (1°C) after 1 hour, and will decrease an additional 2°F (1°C) after another hour.

It will hold the new temperature for 7 hours, then the unit will turn off automatically.

Note: The SLEEP function is not available in FAN or DRY mode.

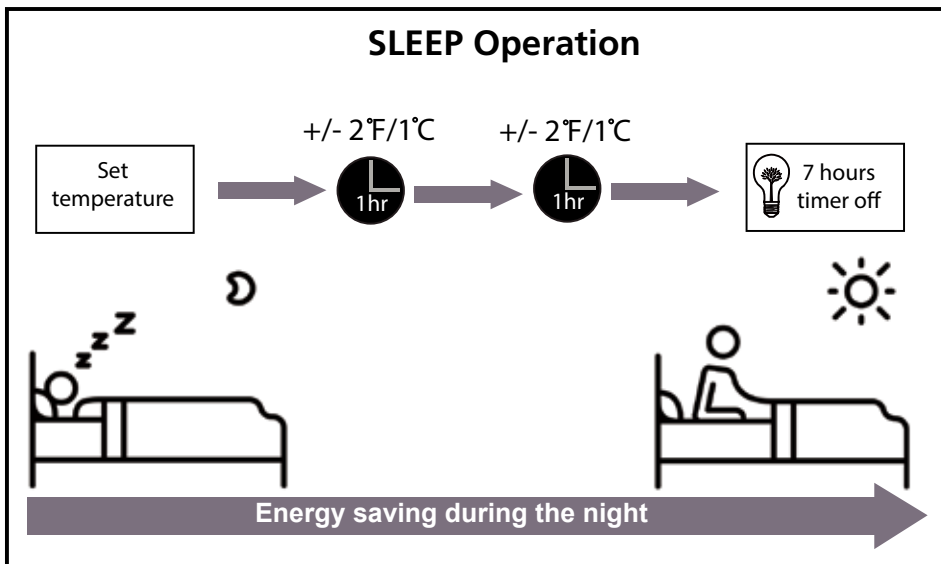

Fig. 3.1

Manual Operation (Without Remote)

2

How to Operate Your Unit without the Remote Control

In the event that your remote control fails to work, your unit can be operated manually with the **MANUAL CONTROL** button, located on the indoor unit. Note that manual operation is not a long-term solution, and that operating the unit with your remote control is strongly recommended.

BEFORE MANUAL OPERATION

The unit must be turned off prior to manual operation.

To operate your unit manually:

1. Open the front panel of the indoor unit.
2. Locate the **MANUAL CONTROL** button on the right-hand side of the unit.
3. Press the **MANUAL CONTROL** button one time to activate FORCED AUTO mode.
4. Press the **MANUAL CONTROL** button again to activate FORCED COOLING mode.
5. Press the **MANUAL CONTROL** button a third time to turn the unit off.
6. Close the front panel.

! CAUTION

The manual button is intended for testing purposes and emergency operation only. Please do not use this function unless the remote is lost and it is absolutely necessary. To restore regular operation, use the remote control to activate the unit.

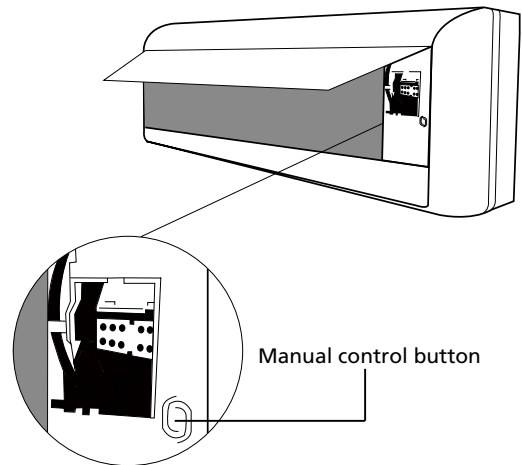

Care and Maintenance

3

Cleaning Your Indoor Unit



BEFORE CLEANING OR MAINTENANCE

ALWAYS TURN OFF YOUR AIR CONDITIONER SYSTEM AND DISCONNECT ITS POWER SUPPLY BEFORE CLEANING OR MAINTENANCE.



CAUTION

Only use a soft, dry cloth to wipe the unit clean. If the unit is especially dirty, you can use a cloth soaked in warm water.

- **Do not** use chemicals or chemically treated cloths to clean the unit
- **Do not** use benzene, paint thinner, polishing powder, or other solvents to clean the unit. These can cause the plastic surface to crack or deform.
- **Do not** use water hotter than 104°F (40°C) to clean the front panel. This can cause the panel to deform or become discolored.

Cleaning Your Air Filter

A clogged air conditioner can reduce the cooling efficiency of your unit and can be bad for your health. Make sure to clean the filter once every two weeks.

1. Lift the front panel of the indoor unit.
2. Grip the tab on the end of the filter, push it up slightly, then pull it a little toward yourself.
3. Pull down to extract the filter.
4. If your filter has a small air freshening filter, unclip it from the larger filter. Clean this air freshening filter with a handheld vacuum.
5. Clean the large air filter with warm, soapy water. Be sure to use a mild detergent.

6. Rinse the filter with fresh water, then shake off excess water.
7. Dry it in a cool, dry place and refrain from exposing it to direct sunlight.
8. When dry, re-clip the air freshening filter to the larger filter, then slide it back into the indoor unit.
9. Close the front panel of the indoor unit.

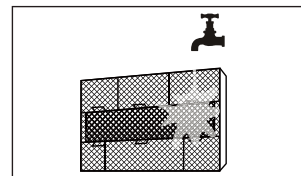
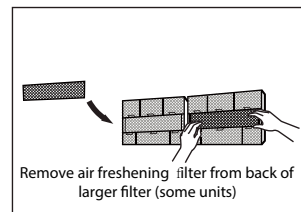
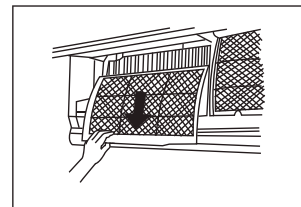
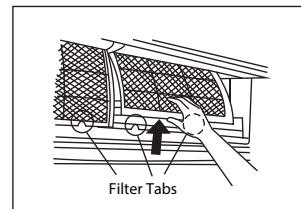

Fig. 5.1



CAUTION

Do not touch the air freshening (Plasma) filter for at least 10 minutes after turning off the unit.

! CAUTION

- Before changing the filter or cleaning, turn off the unit and disconnect its power supply.
- When removing the filter, do not touch metal parts in the unit. The sharp metal edges can cut you.
- Do not use water to clean the inside of the indoor unit. This can destroy the insulation and cause electrical shock.
- Do not expose the filter to direct sunlight when drying. This can shrink the filter.

Air Filter Reminders (Optional)

Air Filter Cleaning Reminder

After 240 hours of use, the display window on the indoor unit will flash “CL.” This is a reminder to clean your filter. After 15 seconds, the unit will revert to its previous display.

To reset the reminder, press the **LED** button on your remote control 4 times, or press the **MANUAL CONTROL** button 3 times. If you don’t reset the reminder, the “CL” indicator will flash again when you restart the unit.

Air Filter Replacement Reminder

After 2,880 hours of use, the display window on the indoor unit will flash “nF.” This is a reminder to replace your filter. After 15 seconds, the unit will revert to its previous display.

To reset the reminder, press the **LED** button on your remote control 4 times, or press the **MANUAL CONTROL** button 3 times. If you don’t reset the reminder, the “nF” indicator will flash again when you restart the unit.

! CAUTION

- Any maintenance and cleaning of the outdoor unit should be performed by an authorized dealer or licensed service provider.
- Any unit repairs should be performed by an authorized dealer or licensed service provider.

Maintenance – Long Periods of Non-Use

If you plan to not use your air conditioner for an extended period of time, do the following:

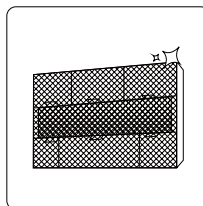

Clean all filters

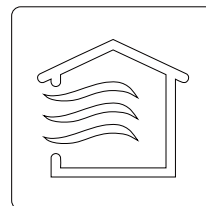

Turn on the FAN function until the unit dries out completely



Turn off the unit and disconnect the power

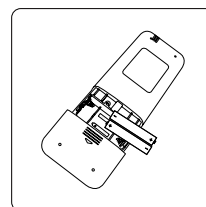

Remove the batteries from the remote control

Maintenance – Pre-Season Inspection

After long periods of non-use, or before periods of frequent use, do the following:

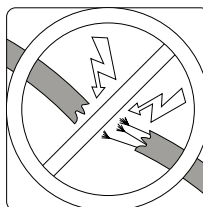

Check for damaged wires

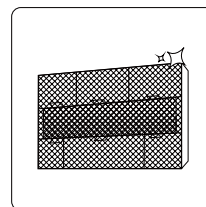

Clean all filters



Check for leaks

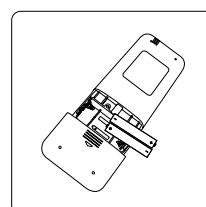

Replace batteries

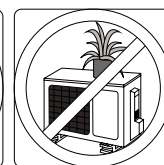
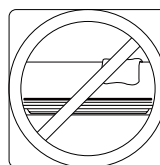

Make sure nothing is blocking any air inlets or outlets

Troubleshooting

4

! SAFETY PRECAUTIONS

If ANY of the following conditions occurs, turn off your unit immediately!

- The power cord is damaged or abnormally warm
- You smell a burning odor
- The unit emits loud or abnormal sounds
- A power fuse blows or the circuit breaker frequently trips
- Water or other objects fall into or out of the unit

DO NOT ATTEMPT TO FIX THESE YOURSELF! CONTACT AN AUTHORIZED SERVICE PROVIDER IMMEDIATELY!

Common Issues

The following problems are not a malfunction and in most situations will not require repairs:

Issue	Possible Causes
The unit does not turn on when you press the ON/OFF button	The unit has a 3-minute protection feature that prevents the unit from overloading. The unit cannot be restarted within three minutes of being turned off.
The unit changes from COOL/HEAT mode to FAN mode	The unit may change its setting to prevent frost from forming on the unit. Once the temperature increases, the unit will start operating in the previously selected mode again.
	The set temperature has been reached, at which point the unit turns off the compressor. The unit will continue operating when the temperature fluctuates again.
The indoor unit emits a white mist	In humid regions, a large temperature difference between the room's air and the conditioned air can cause a white mist.
Both the indoor and outdoor units emit a white mist	When the unit restarts in HEAT mode after defrosting, a white mist may be emitted due to moisture generated from the defrosting process.

Issue	Possible Causes
The indoor unit makes noises	A rushing air sound may occur when the louver resets its position.
	Due to expansion and contraction of the unit's plastic parts, a squeaking sound may occur after the unit is run in HEAT mode.
Both the indoor and outdoor units make noises	Low hissing sound during operation: This is normal and is caused by refrigerant gas flowing through both the indoor and outdoor units.
	Low hissing sound when the system starts, has just stopped running, or is defrosting: This is normal and is caused by the refrigerant gas stopping or changing direction.
	Squeaking sound: Normal expansion and contraction of plastic and metal parts caused by temperature changes during operation can cause squeaking noises.
The outdoor unit makes noises	The unit will make different sounds based on its current operating mode.
Dust is emitted from either the indoor or outdoor unit	The unit may accumulate dust during extended periods of non-use, which will be emitted when the unit is turned on. This can be mitigated by covering the unit during long periods of inactivity.
The unit emits a bad odor	The unit may absorb odors from the environment (such as furniture, cooking, cigarettes, etc.) which will be emitted during operation.
	The unit's filters have become moldy and should be cleaned.
The fan of the outdoor unit does not operate	During operation, the fan speed is controlled to optimize product operation.
Operation is erratic or unpredictable or the unit is unresponsive	<p>Interference from cell phone towers and remote boosters may cause the unit to malfunction.</p> <p>In this case, try the following:</p> <ul style="list-style-type: none"> • Disconnect the power, then reconnect. • Press the ON/OFF button on the remote control to restart operation.

NOTE: If the problem persists, contact a local dealer or your nearest customer service center. Provide them with a detailed description of the unit malfunction, as well as, your model number.

Troubleshooting

When troubles occur, please check the following points before contacting a repair company.

Issue	Possible Causes	Solution
Poor cooling performance	The temperature setting may be higher than ambient room temperature.	Lower the temperature setting.
	The heat exchanger on the indoor or outdoor unit is dirty.	Clean the affected heat exchanger.
	The air filter is dirty.	Remove the filter and clean it according to the instructions.
	The air inlet or outlet of either unit is blocked.	Turn the unit off, remove the obstruction, and turn the unit back on.
	Doors and windows are open.	Make sure that all doors and windows are closed while the unit is operating.
	Excessive heat is generated by sunlight.	Close windows and curtains during periods of high heat or bright sunshine.
	Too many sources of heat are in the room (people, computers, electronics, etc.)	Reduce the amount of heat sources.
	Refrigerant is low due to a leak or long-term use.	Check for leaks, re-seal if necessary, and top off refrigerant.
	The SILENCE function is activated.	The SILENCE function can lower product performance by reducing operating frequency. Turn off the SILENCE function.

Issue	Possible Causes	Solution
The unit is not working	There is a power failure.	Wait for the power to be restored.
	The power is turned off.	Turn on the power.
	The fuse is burned out.	Replace the fuse.
	The remote control batteries are dead.	Replace the batteries.
	The unit's 3-minute protection has been activated.	Wait 3 minutes after restarting the unit.
	The timer is activated.	Turn the timer off.
The unit starts and stops frequently	There's too much or too little refrigerant in the system.	Check for leaks and recharge the system with refrigerant.
	Incompressible gas or moisture has entered the system.	Evacuate and recharge the system with refrigerant.
	The compressor is broken.	Replace the compressor.
	The voltage is too high or too low.	Install a manostat to regulate the voltage.
Poor heating performance	The outdoor temperature is lower than 44.5°F (7°C).	Use an auxiliary heating device.
	Cold air is entering through doors and windows.	Make sure that all doors and windows are closed during use.
	Refrigerant is low due to a leak or long-term use.	Check for leaks, re-seal if necessary, and top off refrigerant.
Indicator lamps continue flashing	The unit may stop operation or continue to run safely. If the indicator lamps continue to flash or error codes appear, wait for about 10 minutes. The problem may resolve itself.	
An error code appears in the window display of the indoor unit:	If not, disconnect the power, then connect it again. Turn the unit on.	
<ul style="list-style-type: none"> • E0, E1, E2... • P1, P2, P3... • F1, F2, F3... 	If the problem persists, disconnect the power and contact your nearest customer service center.	

NOTE: If your problem persists after performing the checks and diagnostics above, turn off your unit immediately and contact an authorized service center.

SYSTEM OPERATION

COOLING OPERATION

How it works:

In cooling mode, your indoor unit will absorb heat from the room, then the outdoor unit will discharge the heat to the outdoors. The cooling capacity decreases as the outdoor temperature increases. This causes the air conditioner to work harder and longer to hold the selected room temperature.

Indoor Coil Freeze Protection:

Frost may form on the indoor coil during cooling operations when the outdoor temperature is below 50°F (10°C). Prolonging operation may cause ice to form on the indoor coil and block airflow. If the indoor unit microcomputer detects ice on the indoor coil, it will stop the compressor to defrost the coil and protect the unit.

HEATING OPERATION

How it works:

In heating mode, your outdoor unit will absorb heat from the outdoor ambient, then the indoor unit will discharge the heat to the room. The heating capacity will decrease as the outdoor temperature decreases.

During extremely cold outdoor temperatures, you may need an additional heating source to supplement the heating output.

Defrost Function:

In heating mode, frost may form on the outdoor coil during humid and low outdoor temperature conditions. Prolonging operation may cause ice to form on the outdoor coil and block airflow. This will reduce the heating capacity.

If the microcomputer detects ice on the outdoor coil, it will switch automatically to defrost mode to melt the ice and clear the coil. During defrost mode, heating will be discontinued and the indoor unit will flash the defrost indicator. The compressor will continue to run, but the indoor and outdoor fans will stop. It is normal to see steam or vapor coming from the outdoor unit during defrost mode. Defrost mode will terminate 12 minutes after initiation of the defrost cycle or when the outdoor coil temperature is 50°F (10°C) or greater.

ENERGY-SAVING TIPS

- 1. Relaxing room temperature at night is OK:** During the nighttime hours, you don't require the same level of conscious cooling or heating. Try using Sleep Mode to gradually relax the room temperature and allow the unit to run less and save energy.
- 2. Curtains and shades:** In the summer, you need to block the effects of the sun. Close window curtains and shades on the south and west sides of your home to help block solar heat. In winter, the sun is your friend. Open curtains and shades to allow solar heat into your room.
- 3. Close doors:** If you don't need to heat and cool your entire home, confine the heating and cooling to one room by closing doors. Limit the space you're heating and cooling to the specified capability of the unit.
- 4. Service the unit:** You may need only some basic maintenance. The outdoor unit will greatly benefit from a good hosing out, especially in treed areas where seeds and other debris can stick to coil fins and make the unit work up to 15% harder.
- 5. Rearrange the room:** If furniture obstructs airflow, you could be heating and cooling the back of a chair or the front of a sofa instead of actual living space. Use the swing louvers to help point the air in the right direction for the room. Remove or rearrange obstacles that block airflow.
- 6. Lighting:** Turning lights off can help reduce heat. Each light bulb is a tiny heater. Your air conditioner wastes energy overcoming the heat from your lights to reach and hold your desired room temperature.
- 7. Is anyone home?** If possible, while you're away, turn your unit to Auto mode and make sure windows and drapes are closed. Although the room temperature will be uncomfortable for a few minutes when you come home, the unit will bring the room back to your desired temperature in no time.
- 8. Don't forget the fan:** The fan is much like a car: the faster it runs, the more energy it uses. Sometimes we need the car to go fast, but slow is good enough most of the time. Try saving money by using the comfortable and quiet low fan speed as much as possible.



LIMITED WARRANTY STATEMENT

Split Air Conditioner with Heat Pump

**This warranty should be registered on our web-site www.cooperandhunter.us
The warranty is only valid when installed by a Licensed HVAC Technician**

FOR WARRANTY SERVICE OR REPAIR:

Contact your installing contractor. You may find the installer's name on the equipment or in your Owner's packet.

Complete product registration below and send back by e-mail at warranty@cooperandhunter.us

PRODUCT REGISTRATION:

Model No.: _____

Serial No.: _____ Date of Installation: _____

Owner Name: _____

Address of Installation: _____

Installing Contractor: _____

Address: _____

Phone No. / E-mail: _____

Place Of Purchase: _____

Date of Purchase: _____

C&H distributor (hereinafter "Company") warrants this product against failure due to defect in materials or workmanship under normal use and maintenance as follows. All warranty periods begin on the date of original installation. If the date cannot be verified, the warranty period begins one hundred twenty (120) days from date of manufacture. Damage resulting from failure to use, install or maintain the product in a manner consistent with our/manufacturer's recommendations shall render the warranty void. Cooper&Hunter, at its option, may request a report from a qualified technician prior to honoring a warranty claim. If a part fails due to defect during the applicable warranty period Company will provide a new or remanufactured part, at Company's option, to replace the failed defective part at no charge for the part. This limited warranty is subject to all provisions, conditions, limitations and exclusions listed below.

- A warranty period of Seven (7) years on compressor to the original registered end-user.
- A warranty period of Five (5) years on all parts to the original registered end user.
- A warranty period of One (1) year on the remote control provided with the original unit.
- Limited warranty applies only to systems that are properly installed by a state certified or licensed HVAC contractor, under applicable local and state law in accordance with all applicable building codes and permits; C&H installation and operation instructions and good trade practices.
- Warranty applies only to products remaining in their original installation location.
- Defective parts must be returned to the distributor through a registered servicing dealer for credit.

LIMITATIONS OF WARRANTIES: ALL IMPLIED WARRANTIES AND/OR CONDITIONS (INCLUDING IMPLIED WARRANTIES OR CONDITIONS OF MERCHANTABILITY AND FITNESS FOR A PARTICULAR USE OR PURPOSE) ARE LIMITED TO THE DURATION OF THIS LIMITED WARRANTY. SOME STATES OR PROVINCES DO NOT ALLOW LIMITATIONS ON HOW LONG AN IMPLIED WARRANTY OR CONDITION LASTS, SO THE ABOVE MAY NOT APPLY TO YOU. THE EXPRESS WARRANTIES MADE IN THIS WARRANTY ARE EXCLUSIVE AND MAY NOT BE ALTERED, ENLARGED, OR CHANGED BY ANY DISTRIBUTOR, DEALER, OR OTHER PERSON, WHATSOEVER.

THIS WARRANTY DOES NOT COVER:

1. Labor or other costs incurred for diagnosing, repairing, removing, installing, shipping, servicing, or handling of defective parts, replacement parts, or new units.
2. Product cleaning required prior to warranty service and repair.
3. Normal maintenance as outlined in the installation and servicing instructions or user's manual, including filter cleaning and/or replacement and lubrication.
4. Failure, damage, or repairs due to faulty installation, misapplication, abuse, improper servicing, unauthorized alteration, or improper operation.
5. Failure to start due to voltage conditions, blown fuses, open circuit breakers, or damages due to the inadequacy or interruption of electrical service.
6. Failure or damage due to floods, winds, fires, lightning, accidents, corrosive environments (rust, etc.), or other conditions beyond the control of Company.
7. Failure or damage of coils or piping due to corrosion on installations within one (1) mile of a sea coast or a corrosive body.
8. Parts not supplied or designated by Company, or damages resulting from their use.
9. Products installed outside the continental USA and Canada.
10. Electricity or fuel costs, or increases in electricity or fuel costs for any reason whatsoever, including additional or unusual use of supplemental electric heat.
11. Any cost to replace, refill, or dispose of refrigerant, including the cost of refrigerant.
12. Shipping damage or damage as a result of transporting the unit.
13. Accessories such as condensate pumps, line sets, and so forth.
14. Any special, indirect, or consequential property or commercial damage of any nature whatsoever. Some states or provinces do not allow the exclusion of incidental or consequential damages, so the above limitation may not apply to you.

This warranty gives you specific legal rights, and you may also have other rights which vary from state to state or province to province.

The design and specifications are subject to change without prior notice for product improvement. Consult with the sales agency or manufacturer for details.