

Operating and Installation Instructions Gas Cooktop

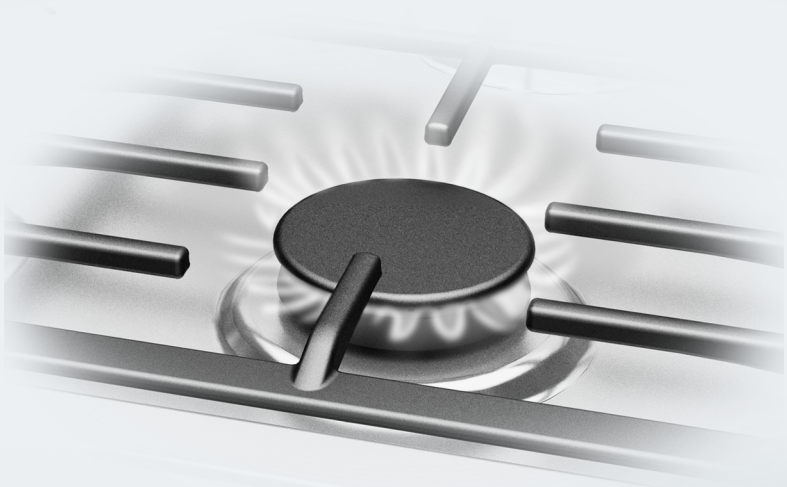

To prevent accidents and machine damage, read the Operating Manual **before** installation or use.

WARNING:

If the information in this manual is not followed exactly, a fire or explosion may result causing property damage, personal injury or death.

- Do not store or use gasoline or other flammable vapors and liquids in the vicinity of this or any other appliance.
- **WHAT TO DO IF YOU SMELL GAS**
 - Do not try to light any appliance.
 - Do not touch any electrical switch.
 - Do not use any phone in your building.
 - Immediately call your gas supplier from a neighbor's phone. Follow the gas supplier's instructions.
 - If you cannot reach your gas supplier, call the fire department.
- Installation and service must be performed by a qualified installer, service agency or the gas supplier.
(In Massachusetts installation must be performed by a licensed plumber / gas fitter.)
- Note to the installer:
Please leave this instruction book with the consumer for the local electrical / gas inspector's use.



Contents

IMPORTANT SAFETY INSTRUCTIONS	6
Appliance description	11
Cooktop	11
Timer display	13
Burner	14
Before the first use	15
Operation	16
Fast-Ignition system	16
Control knobs	16
Burners	16
Turning on	17
Regulating	18
Switching off	18
Quick turn-off	19
Operating/Residual heat indicator	19
Timer	20
Setting the timer	20
Changing the time set	20
Canceling the timer	20
Assigning a timer to a burner	21
Cookware	22
Energy saving tips	24
Safety devices	25
Ignition safety control	25
Safety turn-off	25
Start-up lock	25
Cleaning and care	26
Frequently asked questions	30



Technical Service	32
IMPORTANT INSTALLATION SAFETY INSTRUCTIONS	34
Installation dimensions	37
Installation	38
Electrical connection	40
Wiring diagram	41
Gas connection	42
Gas pressure regulator	43
Conversion to another type of gas	44
Burner capacity	45
Help protect our environment	46

IMPORTANT SAFETY INSTRUCTIONS

WARNING - When using your gas appliance follow basic precautions, including the following:

This gas cooktop conforms to all uniform safety codes and regulations.

Read all instructions before installation or use to prevent injury and appliance damage.

These instructions contain important information on installation, safety, use and maintenance of this appliance. They will help you avoid injury and damage to the appliance.

Keep these operating instructions in a safe place and pass them on to any future user.

SAVE THESE INSTRUCTIONS

Correct usage

- ▶ This appliance is intended for use in domestic households and in similar working and residential environments.
- ▶ Only use this gas cooktop for residential purposes such as cooking and keeping food warm. Other uses are not permitted and can be dangerous.
- ▶ This appliance is not intended for outdoor use.
- ▶ This equipment has not been designed for maritime use or for use in mobile installations such as aircraft or recreational vehicles.
- ▶ Persons who lack physical, sensory or mental abilities, or experience with the appliance should not use it without supervision or instruction by a responsible person.

IMPORTANT SAFETY INSTRUCTIONS

Children

▶ Use the Safety Lock to prevent the cooktop from being turned on.

▶ Children should not be left unattended in an area where the appliance is in use. Never allow children to sit or stand on any part of the appliance.

Caution: Do not store items of interest to children in cabinets above the appliance. Children climbing on the appliance to reach these items could be injured.

▶ The appliance is hot during use and remains so for some time after being switched off. Keep children away from the appliance.

▶ Keep all pots and pans out of the reach of children. Danger of burning or scalding.

▶ Ensure that any packing material, is disposed of safely and kept out of the reach of children. Danger of suffocation!

Technical safety

▶ Installation, repair and maintenance work should be performed by a Miele authorized service technician in accordance with local building and safety codes. Work by unqualified persons could be dangerous and may void the warranty.

▶ Before installing the cooktop, check for externally visible damage. **Do not** operate a damaged appliance. A damaged gas cooktop is a hazard.

▶ Be certain your appliance is properly installed and grounded by a qualified technician.

▶ To guarantee the electrical safety of this appliance, continuity must exist between the appliance and an effective grounding system. It is imperative that this basic safety requirement be met. If there is any doubt, have the electrical system of the house checked by a qualified electrician.

▶ Before installation, make sure that the voltage and frequency listed on the rating label correspond with the household electrical supply. This data must correspond to prevent injury and appliance damage. Consult a qualified electrician if in doubt.

▶ Do not operate the appliance until it has been properly installed in the countertop.

▶ Under no circumstance open the outer casing of the appliance. This is a safety hazard and may damage the appliance.

IMPORTANT SAFETY INSTRUCTIONS

▶ Before servicing, turn off the gas valve and disconnect the power supply by either removing the fuse, unplugging the unit or manually "tripping" the circuit breaker.

▶ While the appliance is under warranty repairs should only be performed by a Miele authorized service technician. Otherwise the warranty is void.

▶ Defective components should be replaced by Miele original spare parts only. Only with these parts can the manufacturer guarantee the safety of the appliance.

▶ The appliance is not designed for use with an external timer or a remote control system.

▶ Do not operate any appliance with a damaged cord or plug, or if the appliance has been damaged in any manner. Contact Miele's Technical Service Department.

▶ Do not use an extension cord to connect this appliance to electricity. Extension cords do not guarantee the required safety of the appliance.

▶ In the event of damage or defect, turn off the appliance immediately. Turn off the gas shut off valve and disconnect completely from the electrical supply. Contact the Miele Technical Service Department. Do not use the appliance until it has been repaired. Ensure power is not supplied to the appliance while repair work is carried out.

▶ Any breakages or cracks in the ceramic surface of the appliance are defects and must be treated as such. Turn it off immediately. Disconnect the gas cooktop from the electrical and gas supplies. Contact Miele Technical Service.

Safety

▶ The appliance is hot during use and remains so for some time after being switched off. Be careful not to touch the appliance if it may still be hot.

▶ Do not heat empty pots or pans. This may cause damage to the cookware and the surrounding area. Danger of fire.

▶ Do not leave the cooktop unattended while in use. Boil-overs cause smoking, and greasy spill-overs may ignite.

▶ Do not use water on grease fires. Smother any fire or flame using a lid, or use a dry chemical or foam-type extinguisher.

 **WARNING** - NEVER use this appliance as a space heater to heat or warm the room. Doing so may result in carbon monoxide poisoning and overheating.

▶ Protect your hands with oven mitts or potholders when using the appliance. Use only dry, heat resistant potholders. Moist or damp potholders used on hot surfaces can result in steam burns. Do not let the potholder touch the hot heating elements. Do not use towels or other bulky items near the appliance.

IMPORTANT SAFETY INSTRUCTIONS

- ▶ Do not flambé under an exhaust hood. Flames could be drawn up into the hood by the suction or the grease filters may ignite.
- ▶ Be careful not to drop anything on the ceramic surface. Even lightweight objects may cause damage.
- ▶ Do not store items on the appliance when not in use. Items could melt or catch fire from residual heat or if the appliance is turned on inadvertently. Always switch the burner(s) off after use.
- ▶ Do not store aerosols, combustibles or any other easily flammable materials underneath or adjacent to the appliance.
- ▶ Do not use plastic or aluminium foil on any part of the cooktop. It melts at high temperatures. Fire hazard.
- ▶ Do not heat unopened containers. Built-up pressure may cause the container to burst and result in injury.
- ▶ Make sure all components of the gas burner are assembled correctly before using the cooktop.
- ▶ Do not use pans that extend past the burner grate. Using larger pans may cause the flames to spread out and damage the surrounding countertop or other countertop appliances.
- ▶ For safety and stability, do not use pans with a bottom diameter smaller than the burner grate.
- ▶ Only certain types of glass, ceramic or other glazed cookware are suitable for use on a gas cooktop without breaking due to the sudden temperature change.
- ▶ Do not use containers made of plastic or aluminium. They may melt at high temperatures.
- ▶ The burner grates supplied with the appliance must always be used. Never place a pan on the burner by itself.
- ▶ Do not let cooking grease or other flammable materials accumulate on the appliance. Fire Hazard.
- ▶ Place the grates on vertically to prevent any scratches.
- ▶ The use of a gas cooktop leads to the formation of heat, moisture and combustion products in the room where the appliance is installed. Ensure proper attention is paid to the ventilation of the installation area: windows kept open or a ventilation hood installed and running.
- ▶ When using a portable appliance near the cooktop, make sure that its power cord does not come in contact with the cooktop.
- ▶ If there is a drawer directly underneath the appliance without a wooden base in between, ensure that no aerosols, combustible liquids or other easily flammable materials are kept in it. If cutlery inserts are to be placed in the drawer, they must be made of a heat-resistant material.

IMPORTANT SAFETY INSTRUCTIONS

- ▶ Do not use roasting pans, frying pans or grill stones large enough to cover several burners. The resulting heat accumulation can damage the appliance.
- ▶ If the gas cooktop is installed behind a cabinet door, it must only be used with the door open. Only close the cabinet door when the appliance is switched off.
- ▶ If the gas cooktop has not been used for an unusually long time, it should be thoroughly cleaned before using it again and checked that it is working properly by an authorized expert.
- ▶ Before discarding an old appliance, disconnect it from the gas and electrical supply, and cut off the power cord to prevent it from becoming a hazard.

**SAVE THESE INSTRUCTIONS
AND REVIEW THEM
PERIODICALLY**

Cooktop

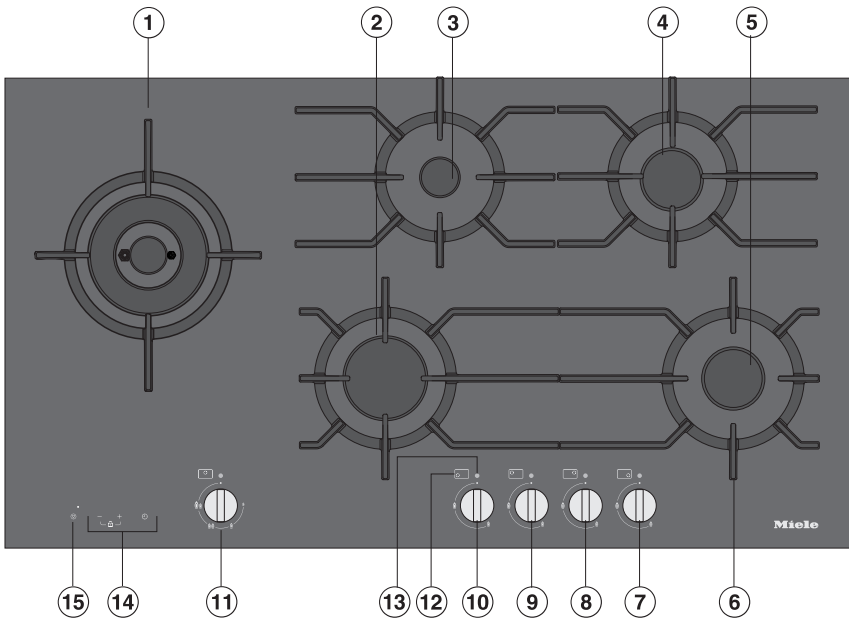

- ① Wok burner
- ② Fast burner
- ③ Auxiliary burner
- ④ ⑤ Normal burner
- ⑥ Grates (for each burner)
- ⑦ Front right burner
- ⑧ Rear right burner
- ⑨ Rear left burner
- ⑩ Front left burner
- ⑪ Left burner
- ⑫ Burner symbol
- ⑬ Operating/Residual heat indicator
- ⑭ Timer
- ⑮ Quick switch-off

Appliance description

Standard accessories

You can re-order standard accessories and optional accessories as needed (see the section on "Optional accessories").

Wok ring



The wok ring (supplied) is included for added stability, especially for woks with round bases.

Combi insert

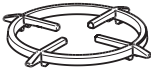

For small and large pans, see "Cookware".

Timer display

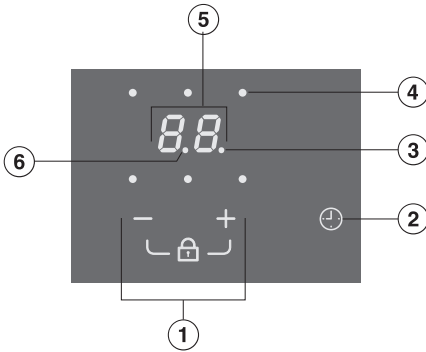

- ① Safety lock / Setting the time
- ② Touch controls
 - Select timer
 - Switch between the functions
 - Select a burner
- ③ Indicator light for the timer
- ④ Indicator light for timer burner assignment, e. g. the rear right burner
- ⑤ Time display
 - 00* to *99* = time in minutes
 - 0.h* to *5.h* = time in hours
- ⑥ Indicator light for half hours for a short time of more than 99 minutes

Appliance description

Burner

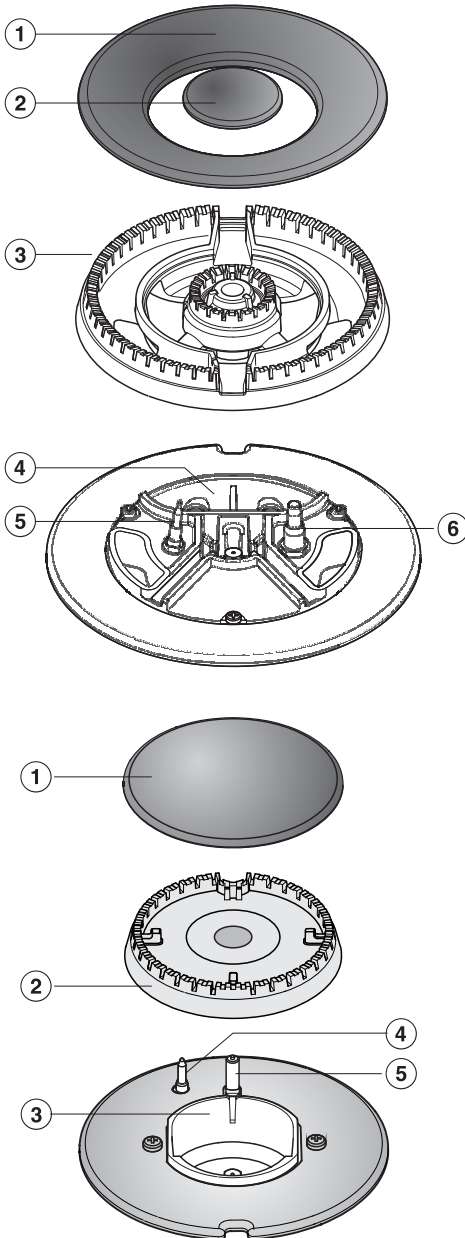

Wok burner

- ① Outer burner cover
- ② Inner burner cover
- ③ Burner head
- ④ Burner base
- ⑤ Ignition safety control (Thermocouple)
- ⑥ Ignitor

Auxiliary, normal, fast burners

- ① Burner cover
- ② Burner head
- ③ Burner base
- ④ Ignition safety control (Thermocouple)
- ⑤ Ignitor

Cleaning the cooktop

- Remove any protective films.
- Wash the removable parts of the gas burner in a mild solution of warm water and liquid dish soap.
- Dry and reassemble the parts in the correct order (see "Cleaning and care").
- Wipe the cooktop with a damp cloth and dry thoroughly.

Metal components have a protective coating which may give off a slight odor the first time your new appliance is heated.

The harmless odor will dissipate after a short time and does not indicate a faulty connection or appliance defect.

Operation

Fast-Ignition system

The appliance is equipped with a quick ignition system with the following features:

- The control knob can be released once it is turned to the largest flame symbol.
- If the flame goes out during use, e.g. from a draft, the burner will automatically reignite. If reignition is unsuccessful, the gas supply will automatically be shut-off (see "Ignition safety control").

Control knobs

The control knob is used to turn on the burner and to regulate the strength of the flame.

Burners

Auxiliary, normal, fast burners

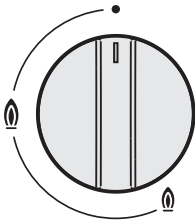

- The gas supply is shut off
- 🔥 Highest flame
- 🔥 Lowest flame

Wok burner

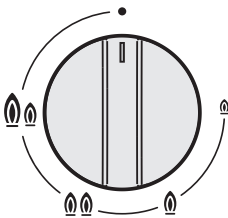

- The gas supply is shut off
- 🔥🔥 Highest flame:
Inner and outer burner burning at the highest level.
- 🔥🔥 High flame:
Outer burner at lowest level,
inner burner at highest level.
- 🔥 Low flame:
Outer burner off,
inner burner at highest level.
- 🔥 Lowest flame:
Outer burner off,
inner burner at lowest level.

Turning on

When using the gas cooktop, an exhaust air extractor hood or a room ventilation device (not recirculation) must be used.

- To light the burner, press the corresponding burner control knob and turn it anti-clockwise to the largest flame symbol. The ignition electrode "clicks" and ignites the gas.

Pressing a burner control knob automatically generates a spark at all burners on the cooktop. This is normal and does not indicate a faulty appliance.

- If the burner has not ignited, turn the burner control knob to "●". Air out the room or wait at least 1 minute before attempting to reignite.
- If the burner does not ignite even at the second attempt, turn the burner control knob to "●" and see "Frequently asked questions".

It may happen that a short re-ignition occurs while switching on (1-2 x clicks) if the thermcouple is not yet sufficiently hot or the flame goes out on the thermcouple or , e.g. from a draft.

Operation

Regulating

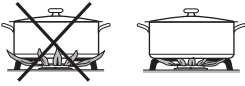

The flame should be regulated so that it never protrudes beyond the pot. Since the outer part of the gas flame is much hotter than the center of the flame, the flame tips should remain under the base of the pot. Protruding flame tips give off unnecessary heat into the air and can damage pot handles and increase the risk of burning.

The burner can be continuously regulated between the highest and lowest flame.

Switching off

- Turn the burner control knob clockwise to "●".

The gas supply is stopped and the flame goes out.

Do not turn the burner control knob clockwise beyond "●".

Quick turn-off

All active burners are turned off by pressing the quick turn-off  touch key.

■ Touch the  touch key.

The operating/residual heat indicator of the active burners flashes.

Any set short time continues to run down if it is not assigned to a burner.

If the short time is assigned to a burner, it is canceled.

The quick switch-off pilot light stays lit until all active burner knobs are turned to "●".

Operating/Residual heat indicator

The operating/residual heat indicator lights up as soon as the burner is turned on and stays lit during use. If the appliance is turned off, the indicator goes out briefly and then lights up again if residual heat is still present.

While the residual heat indicator is lit, do not touch the gas cooktop or place any heat sensitive objects on it. Risk of burns and fire!

Flashing of the display indicates an error message. See "Frequently asked questions".

Timer

You can set a time from 1 minute (01) to 6 (6h) hours. For a time of more than 99 minutes (99), the setting is made in half-hour steps. The half hours are indicated by a dot behind the digit.

The - touch key reduces the time from 6h to 00, the + touch key increases the time from 00 to 6h. There is a stop at 2h or 99. To continue with the setting, briefly take your finger off the touch key and then touch it again.

After the set time has elapsed, 00 appears on the display for a few seconds; a signal also sounds during this time. If you want to stop the signal tone earlier, touch the ⊕ touch key.

The time can be assigned to a burner.

Setting the timer



- Press the ⊕ touch key.

00 flashes on the display and the timer indicator light.

- Press the - or + touch key until the desired time is set, e. g. 15 minutes.

The set time runs down in minutes. You can read the remaining time on the display.

Changing the time set

- Press the touch key ⊕.
- Set the desired time by pressing the - or + touch key.

Canceling the timer

- Press the touch key ⊕.
- Press the - and + touch keys at the same time.

Assigning a timer to a burner

You can set a timer for each active burner.
All burners can be programmed at the same time.

- Turn on the desired burner.
- Press the touch key .

 flashes on the display and the timer indicator light.

- Press the  touch key again.

The indicator light of the timer goes out on the display and a burner assignment indicator light flashes.

- If several burners are turned on, keep pressing the  touch key until the indicator light for the desired burner flashes (rear right).

The indicator lights of the turned on burners appear counter-clockwise starting from front right.

- Press the - or + touch key until the desired time is set, e. g. 15 minutes.

The set time runs down in minutes. You can read the remaining time on the display.

If you want to set a timer for another burner, repeat the process as described above.

If several short times are programmed, the shortest remaining time is displayed and the corresponding indicator light flashes. The other indicator lights stay lit. If you want to display the remaining times running down in the background, keep pressing the  touch key until the desired indicator light flashes.



Cookware



- Select the cookware to match the burner:
large diameter = large burner
small diameter = small burner.
- Using oversized pans may cause the flames to spread out and damage the surrounding countertop or other countertop appliances. The proper pan size will also improve efficiency.
- Pots with a smaller diameter than the pan support and pots that do not sit securely (without wobbling) are hazardous and should not be used.
- Unlike pans used on an electric cooktop, the bases do not need to be even for good results.
- When buying pots and pans, keep in mind that it is generally not the base diameter but the upper diameter which is specified.
- Only use heat-resistant cookware.
- Thick pan bases will give more even results, as hot spots are reduced due to better heat distribution. Thin pan bases will conduct the heat faster but not as evenly as thick pan bases. Stir the food frequently to prevent burning.
- Always place the cookware on the grate. The cookware must not be placed directly on the burner.
- Position the cookware on the grate so that it cannot tip over. A minimum amount of wobbling can never be completely ruled out.
- Do not use pots or pans with edge-supported bases.

Wok ring

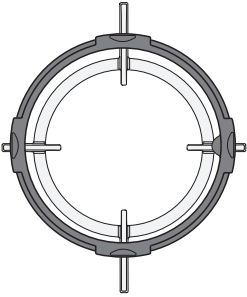

For added stability, especially for woks with round bases, use the wok ring (supplied).

Make sure the wok ring is positioned correctly so that it sits securely and cannot shift. (See illustration.)

Combi insert

The combi insert must be used on the **wok burner**, if you use

- very small cookware. It sits securely and cannot tip over.
- very large cookware. Using the insert will prevent the flames spreading and discoloring the cooktop and damaging the surrounding countertop.

Energy saving tips

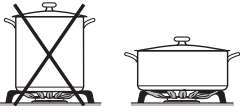

- If possible, cook in covered pots or pans. This prevents unnecessary heat loss.
- Cook with less water.
- The cooking time can be significantly reduced by using a pressure cooker.
- After cooking or frying, promptly set to a lower flame.
- Generally, wide / shallow pans will heat quicker and cook more evenly than narrow / tall ones.

Ignition safety control

Your gas cooktop is equipped with an Ignition safety control. This means that if the gas flame goes out, e.g. from a boilover or a draft. If an attempt to reignite fails, the gas supply shuts off. Any further escape of gas is prevented.

- To reignite the burner turn the knob clockwise to "●" and then turn it on as usual.

Safety turn-off

If a burner is heated for an unusually long time (approx. 6 hours), it turns off automatically.

- To reignite the burner turn the knob clockwise to "●" and then turn it on as usual.

Start-up lock

The start-up lock is activated when a burner is turned off. If it is activated, the burners cannot be turned on and the timer is disabled.

When the start-up lock is activated, the indicator light comes on and **LL** appears on the timer display if you press a touch control or press a burner control knob.

The start-up lock is deactivated if a power failure occurs.

Activating

- Press both - and + touch controls at the same time until **LL** appears on the timer display and a signal sounds.

Deactivating

- Press both - and + touch keys at the same time until a signal sounds.

Cleaning and care

 Never use a steam cleaner to clean this cooktop. Pressurized steam could cause permanent damage to the surface and to components.

Do not use any sharp or pointed objects which could damage the seal between the frame and the countertop.

Keep the ignitor in the burner dry. If it gets wet it will not spark.

Dry your cooktop thoroughly after cleaning it to prevent lime deposits.

Spills containing salt or sugar should be cleaned immediately.

The surfaces of the burner parts and grates become slightly duller over time. This is normal and does not indicate any impairment of the material.

To better maintain your appliance avoid the following:

- cleaners containing soda, ammonia, thinners, or chlorides,
- cleaners containing descaling agents or lime removers,
- abrasive cleaners,
- stainless steel cleaners,
- dishwasher soap,
- caustic (oven) cleaners,
- scouring pads, steel wool, hard brushes,
- metal scrapers.

Glass cleaners may be used to clean the exterior. However **do not** allow them to sit or "puddle", this can cause damage to the surface. **Remove the cleaner promptly.**

Cleaning and care

	Cleaning	Instructions
Ceramic surfaces	<p>Remove heavy dirt with a damp cloth and stubborn dirt with a glass scraper.</p> <p>Clean with the Miele ceramic surface and stainless steel cleaner (see the Miele online store) and with kitchen paper or a clean cloth.</p> <p>Do not apply cleaner to a hot cooktop as this can cause discoloration.</p> <p>Wipe with a damp cloth and dry with a soft cloth.</p>	<p>Do not use liquid dish soap as not all soiling and residue will be removed. This results in an invisible film which causes discoloration of the glass ceramic. This discoloration is permanent.</p> <p>When using special ceramic cleaning agents, follow the instructions of the manufacturer.</p>
Grates	<p>Take out the grates.</p> <p>Clean in the dishwasher or with a sponge cloth, a mild solution of liquid dish soap and warm water.</p> <p>If necessary, use the rough side of the sponge.</p>	<p>Bei hellen Stellen kann es sich um Reinigerreste aus der Spülmaschine oder um Abrieb der Topfböden handeln. Reinigen Sie wie links beschrieben.</p>
Burner control knob	<p>Clean with a sponge cloth, some liquid dish soap and warm water.</p>	<p>Not dishwasher safe.</p>
Burner	<p>Remove all loose parts of the burner.</p> <p>Clean with a sponge cloth, a mild solution of liquid dish soap and warm water.</p> <p>Wipe the non-detachable parts of the burner with a damp cloth.</p>	<p>Not dishwasher suitable.</p> <p>Make sure that the flame openings are completely dry after cleaning.</p>
Ignition safety control (thermocouple)	<p>Wipe carefully with a well damp cloth.</p>	<p>The Ignition safety control (thermocouple) must not become wet, otherwise it will not spark.</p>

Cleaning and care

Assembling the burners

Auxiliary, normal and fast burners

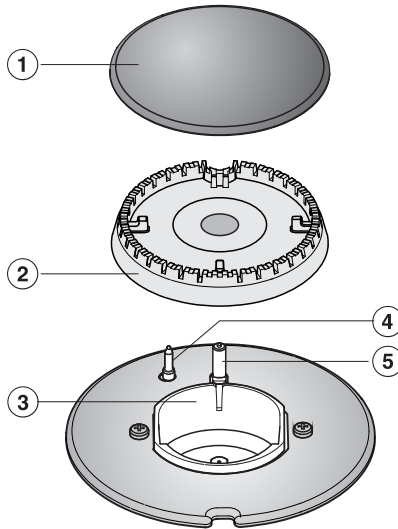

- Place the burner head ② on the burner base ③ so that the thermocouple ④ and the ignitor ⑤ feed through the holes of the burner head. The burner head must engage properly.
- Lay the burner cap ① flat on the burner ring ②.
The burner cap cannot shift if positioned correctly.

Make sure the burner parts are assembled in the right order.

Wok burner

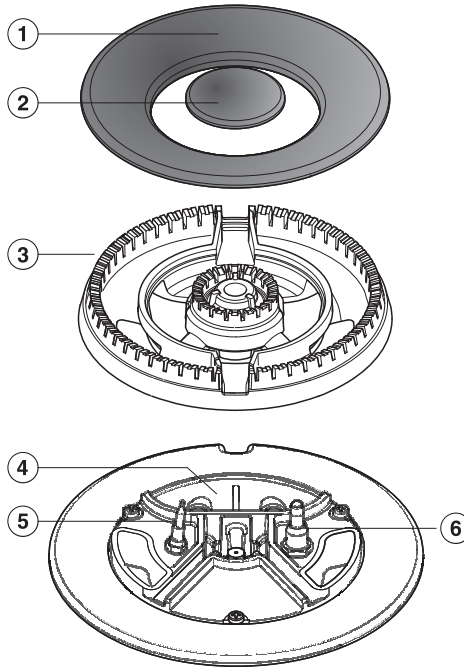

- Place the burner head ③ on the burner base ④ so that the thermocouple ⑤ and the ignitor ⑥ feed through the hole of the burner head. The burner head must engage properly.
- Place on the burner caps ①②.

Make sure the burner parts are assembled in the right order.

Frequently asked questions

 Repairs should only be carried out by an authorized technician in accordance with local and national safety regulations. Unauthorized repairs could cause injury or appliance damage.

Problem	Cause	Solution
The burner does not ignite when used for the first time or after not being used for a longer period.	There may be air in the gas line.	Repeat the ignition process several times if necessary.
The burner does not ignite after several attempts		Turn all burner control knobs to "●" and disconnect the power to the appliance for few seconds
	The burner is not assembled correctly.	Assemble the burner correctly.
	The gas valve is closed.	Open the gas valve.
	The burner is wet and/or dirty.	Clean and dry the burner.
	The igniters are wet.	Dry the igniters.
Power failure during use		Turn all burner control knobs to the clockwise to "●". When the power is restored, you can use the appliance as normal.
Flame goes out after ignition	<ul style="list-style-type: none"> - Residue has been built up between the ignitor and the burner. - The burners are assembled incorrectly. 	<p>Clean the burners</p> <p>Position the burner parts correctly.</p>
The shape of the gas flame varies	The burner parts are not positioned correctly.	Position the burner parts correctly.
	The burner head or burner cover holes are dirty.	Remove the dirt.
Flame goes out during use	The burner parts are not positioned correctly.	Position the burner parts correctly.
	Power failure	Turn all burner control knobs to the clockwise to "●". When the power is restored, the appliance can be used as usual.
The operating/residual heat indicator of a burner flashes	Power failure	Turn all burner control knobs to the clockwise to "●". When the power is restored, the appliance can be used as usual.

Frequently asked questions

Problem	Cause	Solution
The burner ignitor is not working	The circuit breaker has tripped.	Restore power. If lack of power is the problem, the cooktop can be lit with a match. See "Turning on in the event of a power failure".
	There is food residue between the ignitor and the burner cover.	Clean carefully (see "Cleaning and care").
One of the following error messages appears on the timer display: <i>LC</i>	The start-up lock is activated.	Deactivate the start-up lock (see chapter "Start-up lock").
<i>FL</i>	Sensor error	First make sure there is no direct light (sunlight or artificial light) falling on the cooktop and that the surroundings of the cooktop are not too dark. Make sure that the entire cooktop and the touch controls are not covered. Remove any cookware and clean the cooktop of any residues. Turn off the power supply of the cooktop for approx. 1 minute. If the problem persists, please contact technical service.
<i>F2</i> (the operating/residual heat indicator is flashing)	The overheating protection has triggered	None! Turn all burner control knobs to the right to "●". You can use the burners again when <i>F2</i> goes out.
<i>E0</i> (The operating/residual heat indicator is flashing)	Electronics fault	Reset: Press the touch control of the quick switch-off for 3 seconds. If the problem persists, please contact technical service.
All other error messages	An error has occurred with the electronics.	Turn off the power supply of the cooktop for approx. 1 minute. If the problem persists after restoring the power supply, please contact technical service.

Technical Service

In the event of a fault which you cannot easily fix yourself, please contact the Miele Technical Service Department at the address on the back of this booklet. When contacting Technical Service please quote the serial number and model of the cooktop.

MieleCare

MieleCare, our Extended ServiceContract program; gives you the assurance of knowing that yourappliance investment is covered by 5 years of worry free ownership. **MieleCare** is the only Extended Service Contract in the industry that guarantees repairs by a Miele Authorized Service Provider using genuine Miele parts. Only genuine Miele parts installed by factory trained professionals can guarantee the safety, reliability and longevity of your Miele appliance.

Please note that unless expressly approved in writing by the Miele Service department, Extended Service Contracts offered by other providers for Miele products will not be recognized by Miele. Our goal is to prevent unauthorized (and untrained) service personnel from working on your Miele products, possibly doing further damage to them, you and/or your home.

To learn more about **MieleCare** Extended Service Contracts, please contact your appliance dealer or visit us online at:

<http://mieleusa.com>

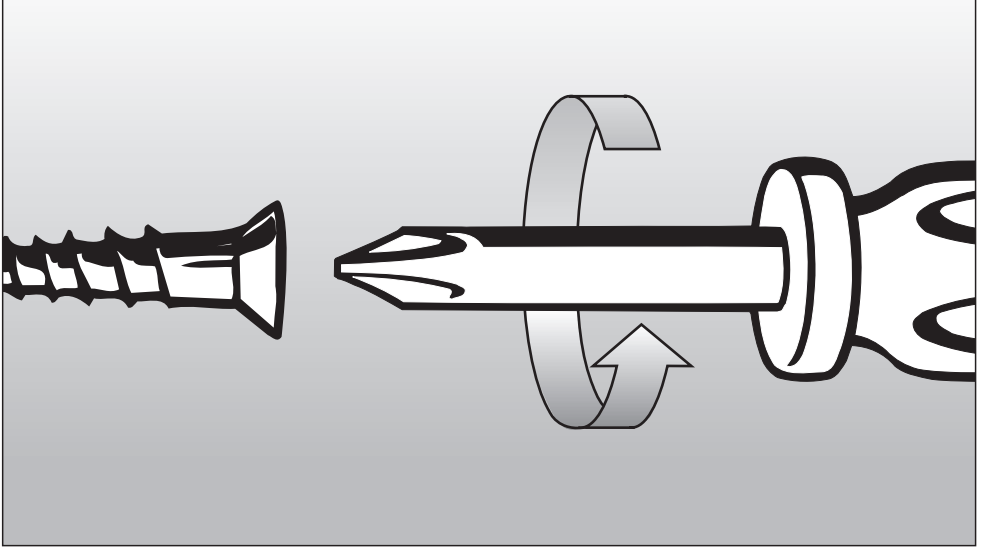

Installation Instructions

IMPORTANT: SAVE FOR THE LOCAL ELECTRICAL INSPECTOR'S USE

Information is subject to change. Please refer to our website to obtain the most current product specification, technical & warranty information.

To prevent accidents and appliance damage read these instructions **before** installation or use.

IMPORTANT INSTALLATION SAFETY INSTRUCTIONS

Installation

The minimum distances given in these Installation instructions are to combustible surfaces, and must be observed to ensure safe operation. Failure to do so increases the risk of fire.

The cabinetry and venting hood should be installed first to prevent damage to the cooktop.

- ▶ Gas appliances should only be installed in a well ventilated area.
- ▶ The countertop must be bonded with heat resistant (212°F/100°C) adhesive to prevent distortion or dissolving. Any wall coverings must be heat resistant as well.
- ▶ This appliance must not be used in a non-stationary location (e.g. on a ship).
- ▶ Deep fat fryers must not be installed directly next to gas cooktops. Gas flames can ignite splattering oil. A distance of at least 11 3/4" (300 mm) should be maintained between these two appliances.
- ▶ The cooktop must not be installed over a dishwasher, washer, dryer, refrigerator or freezer. Heat radiated by the cooktop may damage the appliances.
- ▶ Install the appliance so that the power cord or gas piping does not come into contact with any portion of the cooktop which may become hot during use.

- ▶ The power cord and a flexible gas connection line must be attached so that they are not in contact with moving parts of kitchen elements (e.g. a drawer) and are not subjected to mechanical stress.
- ▶ The safety distances listed on the following pages must be carefully maintained.
- ▶ Never use a sealant unless expressly specified. The sealing tape of the appliance ensures adequate sealing to the worktop.

 This appliance must be installed with its own shut off valve and the included gas pressure regulator. Both the valve and the regulator must be easily accessible to the consumer after the appliance is installed.

This appliance must be disconnected from the gas supply during any pressure testing of the system performed in excess of 1/2 psi (3.5 kPa). This appliance must be isolated at test pressures equal to or less than 1/2 psi (3.5 kPa).

Any pipe connections must be made using a thread sealant approved for gas connections. Failure to correctly install these items could lead to a gas leak and subsequent explosion.

IMPORTANT INSTALLATION SAFETY INSTRUCTIONS

Safety distances above the appliance

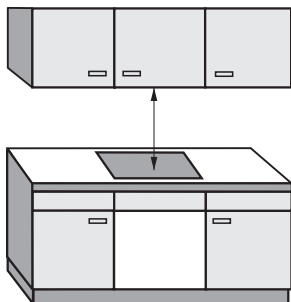

The minimum safety distance given by the hood manufacturer must be maintained between the cooktop and the hood above it. See the installation instructions of the hood for these safety measurements.

If the hood manufacturer's instructions are not available or if flammable objects are installed over the cooktop (e.g. cabinets, utensil rail, etc.), a minimum safety distance of 30" (760 mm) must be maintained.

If there is more than one appliance beneath a hood (e.g. gas cooktop and electric cooktop), and they have different minimum safety distances always observe the greater distance.

IMPORTANT INSTALLATION SAFETY INSTRUCTIONS

Safety distances

When installing a gas cooktop, there may be cupboard or room walls of any height on the rear side and on one side (right **or** left) (see illustrations).

The minimum following safety distances must be maintained:

- ① 2" (50 mm) **rear** minimum distance from the countertop cut-out to the countertop rear edge.
- ② 5 7/8" (150 mm) **right** minimum distance from the countertop cut-out to an adjacent piece of furniture (e. g. tall cabinet) or a room wall.
- ② 5 7/8" (150 mm) **left** minimum distance from the countertop cut-out to an adjacent piece of furniture (e. g. tall cabinet) or a room wall.

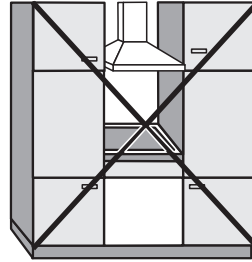

Not allowed

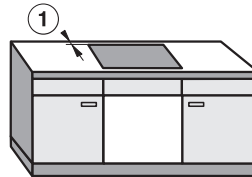
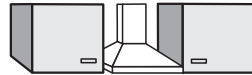

Recommended

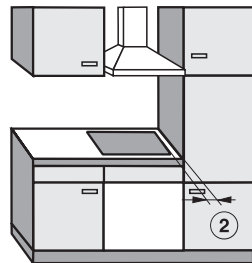

Not recommended

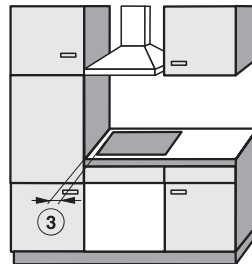

Not recommended

Installation dimensions

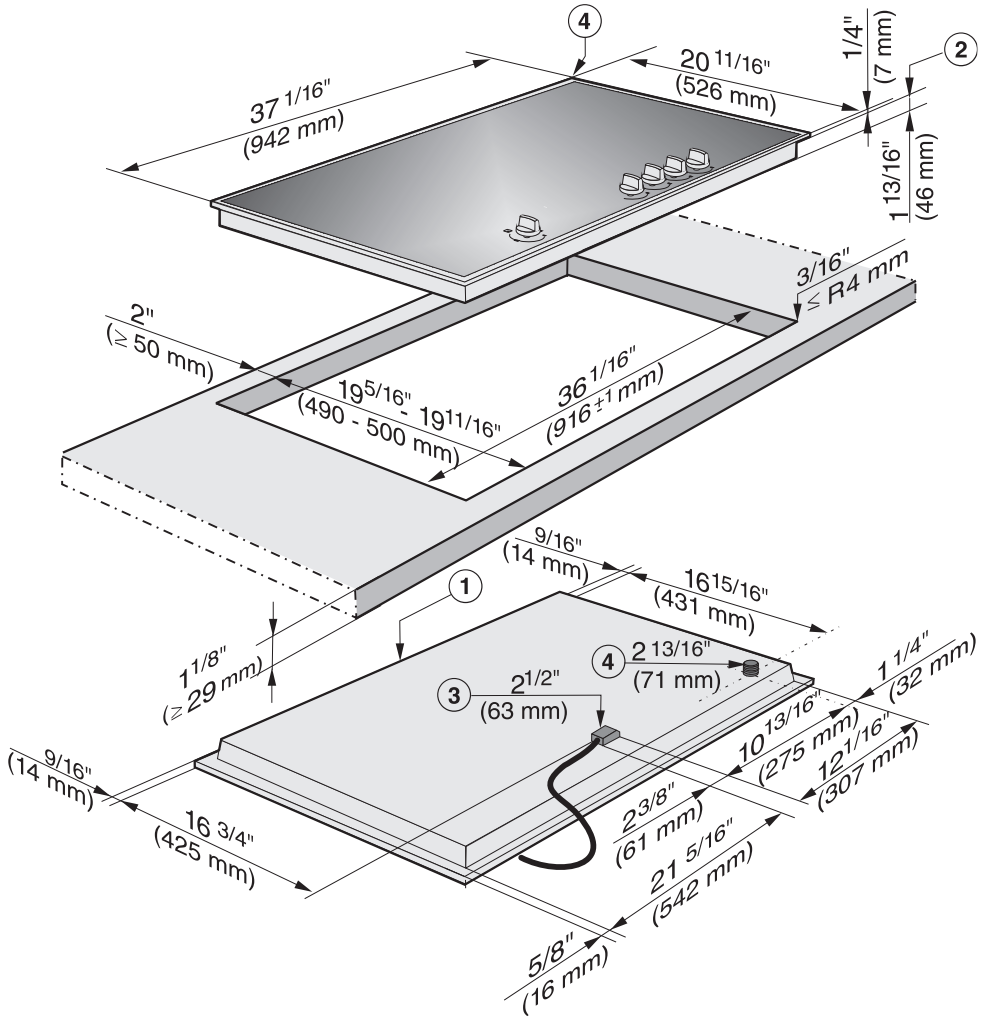

- ① Appliance front
- ② Installation height
- ③ Power supply box with connection cable L = 4 ft (1.2 m)
- ④ Gas connection

Installation

- Create the countertop cutout as per the dimension drawing. Remember to maintain a **minimum safety distance** from the **back wall**, as well as from any **tall unit or side wall** to the right or left of the cooktop (see "IMPORTANT INSTALLATION SAFETY INSTRUCTIONS").
- Seal the cut surfaces with a suitable heat-resistant sealant to avoid swelling caused by moisture. The materials used must be heat-resistant.

Make sure that these materials do not touch the surface of the countertop.

- Feed the appliance power cord downwards through the countertop cutout.
- Place the appliance loosely in the cutout.

If during installation the seal around the frame does not sit flush with the countertop in the corners, the corner radius, maximum $\frac{3}{16}$ " (4 mm), can be carefully filed down to fit.

- Connect the appliance to the electrical supply (see "Electrical connection").
- Connect the gas (see "Gas connection").

- Secure the appliance in place with the supplied brackets ①.

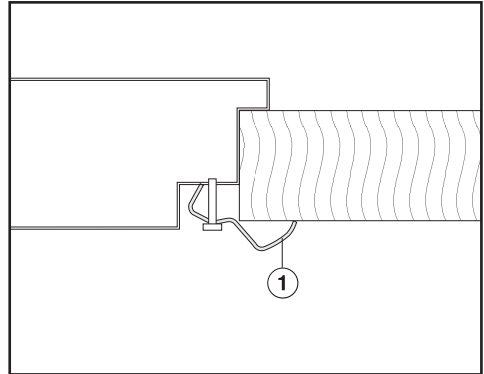

After installation

After installing the appliance, check the cooktop function by turning on all burners.

In the "low setting", the gas flame must not go out, even if the burner knob is quickly turned from the "high setting" to the "low setting".

In the "high setting", the gas flame must burn with a clearly visible center.

Sealing

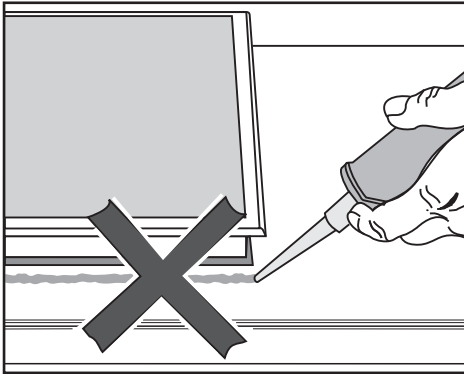

The sealing strip under the edge of the top part of the cooktop provides a sufficient seal for the countertop.

Do not let sealant get in between the cooktop frame and the countertop. This could cause difficulties if the cooktop ever needs to be taken out for servicing and possibly result in damage to the cooktop frame or the countertop.

Tiled surfaces

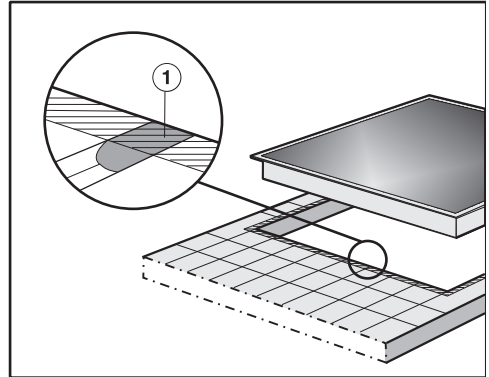

The grouting ① and shaded area under the appliance frame must be flat and even so that the frame will lie evenly and the sealing strip under the edge of the upper part of the appliance can provide an adequate seal against the countertop.

Electrical connection

This appliance must be grounded according to local or national codes.

All electrical work should be performed by a qualified electrician in accordance with local codes and with the:

- National Electrical Code ANSI / NFPA No. 70 for the USA

or

- Canadian Electrical Code Part I for Canada (CSA Standard C 22.1).

This appliance is equipped with a three-prong grounding plug to prevent shock hazards. It should be plugged directly into a properly grounded outlet. Do not cut or remove the grounding prong from the plug. If the plug does not fit the outlet, have the proper outlet installed by a licensed electrician.

To guarantee the electrical safety of this appliance, continuity must exist between the appliance and an effective grounding system. It is imperative that this basic safety requirement be met. If there is any doubt, have the electrical system of the house checked by a qualified electrician.

WARNING

Disconnect the appliance from the main power supply before installation or service. To reduce the risk of electric shock, make sure that the appliance is properly grounded after installation.

Note to the installer

Please leave these instructions with the consumer or the appliance.

Power supply

The automatic ignition requires that the appliance be connected to a 120 VAC, 60 Hz power supply. The supply line should be protected by a 15 A fuse.

Actual power consumption (during ignition only) is 25 W.

This appliance is equipped with a 4 ft (1.2 m) long power cord that is ready for connection to the appropriate outlet.

Place the power outlet so that it is accessible after the appliance has been installed in the countertop.

Wiring diagram

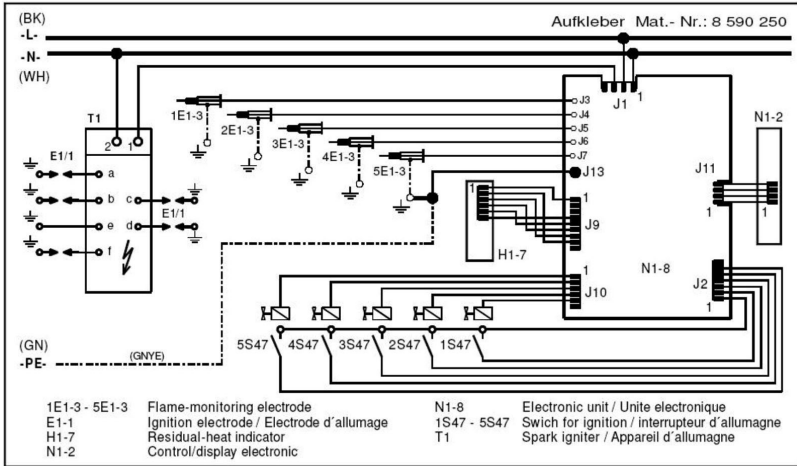

⚠ Caution: Label all wires prior to disconnection when servicing controls. Wiring errors can cause improper and dangerous operation. Verify proper operation after servicing.

Gas connection

Installation and service must be performed by a qualified installer, service agency or gas supplier.

In Massachusetts installation must be performed by a licensed plumber/gas fitter.

This appliance must be installed with its own shut off valve and the included gas pressure regulator. Both the valve and the regulator must be easily accessible to the consumer to turn on or shut off the gas supply after the appliance is installed.

This appliance and its individual shut off valve must be disconnected from the gas supply during any pressure testing of that system performed in excess of $\frac{1}{2}$ psi (3.5 kPa). The appliance must be isolated from the gas supply line by closing its individual manual shut off valve at test pressures equal to or less than $\frac{1}{2}$ psi (3.5 kPa).

Any pipe connections must be made using a thread sealant approved for gas connections. Failure to correctly install these items could lead to a gas leak and subsequent explosion.

Leak testing of the appliance shall be conducted according to the manufacturer's instructions.

The gas connection must be made in accordance with local codes or, in the absence of local codes, with

- the National Fuel Gas Code, ANSI Z 21.1 / NFPA 54 for the USA

or

- the current Can / CGA B 149.1 and .2 Installation Codes for gas burning appliances for Canada.

Make sure that the maximum gas supply pressure before the gas pressure regulator is never more than $\frac{1}{2}$ psi for both natural gas or LP gas.

The minimum required gas supply pressure to get the required gas input is 6" w.c. for natural gas
10" w.c. for LP gas.

Gas pressure regulator

A pressure regulator that is convertible from natural to LP gas (Propane) or vice versa is included with the appliance. The included regulator corresponds with the gas type of the appliance. Verify before installing.

The adjusted pressure is:
natural gas - 4" w.c.
LP gas - 10" w.c.

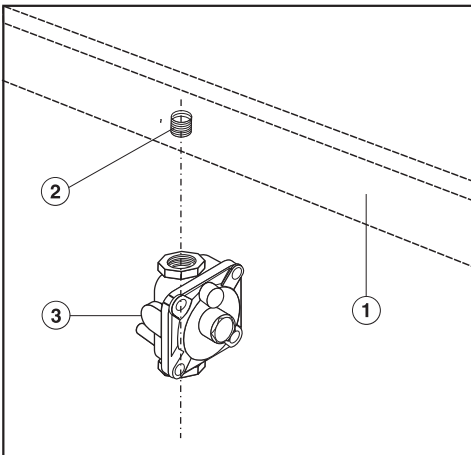

- ① Appliance
- ② 1/2" NPT
- ③ Regulator

As shown in the above diagram, the included regulator **must** be used when connecting the Miele appliance to your gas supply. This item has been customized by Miele to meet all applicable safety requirements. Make sure the regulator is easily accessible for adjustment after the appliance has been installed.

For convenience, an AGA or CGA approved flexible stainless steel gas hose (accordion type) may be used between the gas connection and the regulator. This will allow the appliance to be lifted out of the countertop for cleaning or servicing. Make sure that any drawers, cabinet doors, etc., do not rub on this gas hose.

Do not use any regulator unless it has been supplied by Miele. Doing so may cause a gas leak.

If there is any doubt concerning installation contact the Miele Technical Service Department.

After connecting the appliance check all fittings for gas leaks e.g. with soapy water.

When installed properly, the flame will be steady and quiet. It will also have a sharp, blue inner core that will vary in length proportional to the burner size. Flame adjustment will not be necessary.

Conversion to another type of gas

The appliance should have been ordered for connection to either natural gas or LP gas (propane).

If the appliance is not configured for the proper type of gas connection please contact your Miele Dealer.

Nominal ratings

Maximum output

	Gas type	BTU/hr	kW
Auxiliary burner	Natural Gas (NG)	3,750	1.10
	Propane (LP)	3,300	0.97
Normal burner	Natural Gas (NG)	5,800	1.70
	Propane (LP)	6,400	1.88
Fast burner	Natural Gas (NG)	9,300	2.73
	Propane (LP)	9,800	2.87
Wok Burner	Natural Gas (NG)	16,500	4.84
	Propane (LP)	15,000	4.40
Total output	Natural Gas (NG)	41,150	12.10
	Propane (LP)	40,900	12.00

Minimum output

	Gas type	BTU/hr	kW
Auxiliary burner	Natural Gas (NG)	1,000	0.29
	Propane (LP)	1,700	0.50
Normal burner	Natural Gas (NG)	1,450	0.42
	Propane (LP)	1,300	0.38
Fast burner	Natural Gas (NG)	2,000	0.59
	Propane (LP)	2,100	0.62
Wok burner	Natural Gas (NG)	800	0.23
	Propane (LP)	900	0.26

Help protect our environment

Disposal of packing materials

The cardboard box and packing materials are biodegradable and recyclable. Please recycle.

Ensure that any plastic wrappings, bags, etc. are disposed of safely and kept out of the reach of children.
Danger of suffocation!

Disposal of an old appliance

Old appliances contain materials that can be recycled. Please contact your local recycling authority about the possibility of recycling these materials.

Before discarding an old appliance disconnect it from the electrical supply and cut off the power cord to prevent it from becoming a hazard.

Please have the model and serial number of your appliance available before contacting Technical Service.

Miele

U.S.A.

Miele, Inc.

National Headquarters

9 Independence Way
Princeton, NJ 08540
Phone: 800-843-7231
609-419-9898
Fax: 609-419-4298
www.mieleusa.com

Technical Service & Support Nationwide

Phone: 800-999-1360
Fax: 888-586-8056
TechnicalService@mieleusa.com



Canada

**Importer
Miele Limited**

Headquarters and Miele Centre

161 Four Valley Drive
Vaughan, ON L4K 4V8
www.miele.ca

Customer Care Centre

Phone: 800-565-6435
905-532-2272
customercare@miele.ca

Germany

Manufacturer
Miele & Cie. KG
Carl-Miele-Straße 29
33332 Gütersloh

INFORMATION IS SUBJECT TO CHANGE. PLEASE REFER TO OUR WEBSITE TO OBTAIN THE MOST CURRENT PRODUCT SPECIFICATIONS, TECHNICAL & WARRANTY INFORMATION.

KM 3054



en - US, CA

M.-Nr. 09 317 520 / 02