



INSTRUCTION MANUAL

40lb, 75lb, & 110lb

PORTABLE OIL FILTER

This manual contains important information regarding your Adcraft unit. Please read this manual thoroughly prior to equipment set-up, operation and maintenance. Failure to comply with regular maintenance guidelines outlined in this manual may void the warranty.

WARNINGS

- Do not touch any hot surfaces
- Do not immerse unit, cord or plug in liquid at any time
- Unplug cord from outlet when not in use and before cleaning
- Plug only into a 3-hole grounded electrical outlet of appropriate voltage
- Do not operate unattended
- Do not use this unit for anything other than intended use
- Always use on a firm, dry and level surface
- Do not use if unit has a damaged cord or plug, in the event the appliance malfunctions, or has been damaged in any manner
- Keep children and animals away from unit
- Keep machine away from any flammable or explosive liquids or gases
- Any incorrect installation, alterations, adjustments and/or improper maintenance can lead to property loss and injury. All repairs should be done by authorized professionals only.
- Ensure that the designated power supply is adequate for continual usage

TO USE:

1. Place the unit in front of the fryer being emptied.
2. Plug the power cord of the unit into an outlet of appropriate voltage and turn on the unit.
3. Connect the oil hose to the oil drain valve on the unit
4. Make sure filtration system is put together correctly (See filtration system diagram) and is secure in place in the filtering chamber.
5. With the extension drain tube tightened securely on the fryer's oil spout, empty the fryer's oil into the filtering chamber of the oil filter.
6. Once the fryer has been fully emptied of oil, push the filtering button on the filter unit and aim the filtering hose into the new or cleaned out fryer to fill with oil.
7. You can control the flow of oil back into the fryer by tightening or loosening the oil drain valve.
8. Once fryer has been filled up to desired/max capacity, turn off the oil filter to stop the pump from flowing.
9. Put the oil hose back into its holder.
10. Once cooled down fully, remove the filtration system from the chamber.
11. Discard the used filtering sheet and any debris on the filtering mesh, and clean the inside of the chamber.
12. Unscrew the oil tube from the drain valve. The oil tube can be rolled up and stored inside the chamber.

NOTE: To ensure proper filtering of the oil, the oil temperature should be cycled through the filter at a range of 250° - 375°F. If the oil is not hot enough, it will clog up the machine and not filter properly.

40lb Fryer

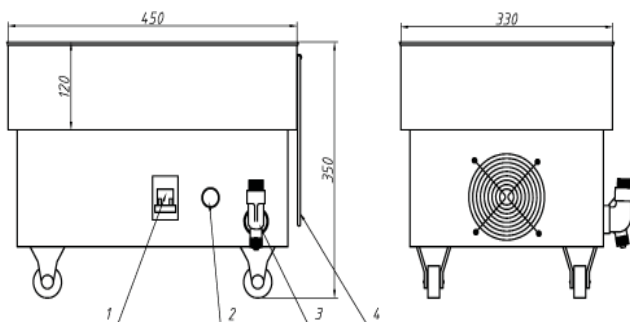

1. Power Switch
2. Filtering Button
3. Oil Drain Valve
4. Handle

75lb Fryer

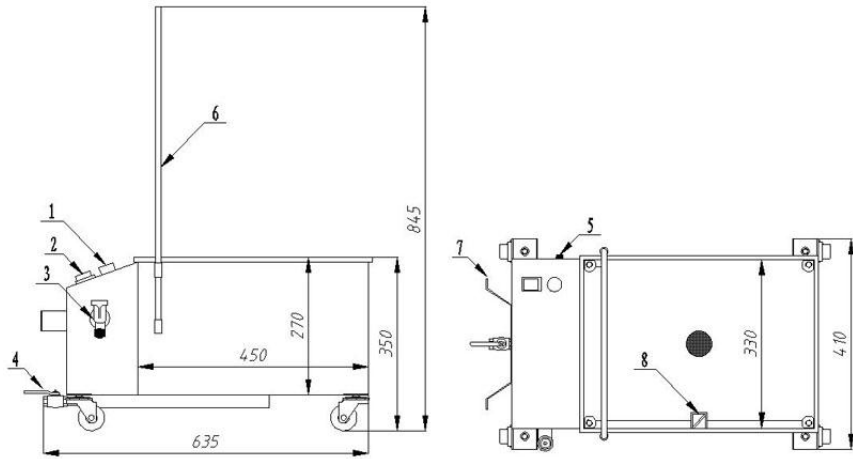

1. Power Indicator
2. On/Off Button
3. Tube Release Valve
4. Machine Release Valve
5. Current Protector
6. Handle
7. Cord Holder
8. Nozzle Holder

110lb Fryer

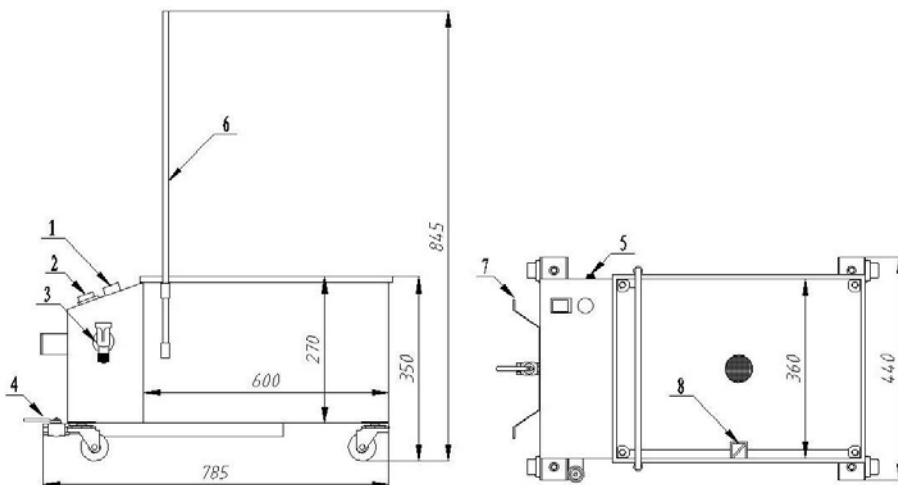

1. Power Indicator
2. On/Off Button
3. Tube Release Valve
4. Machine Release Valve
5. Current Protector
6. Handle
7. Cord Holder
8. Nozzle Holder

OIL FILTRATION SYSTEM

To assemble the filtration system, follow the below instructions and diagram.

Always use a new filtering sheet (sold separately) every time. The filter paper size for this unit measures 17.75" x 13".

1. Place the square rubber gasket at the bottom of the filtering chamber.
2. Put the stainless steel filtering mesh inside the gasket.
3. Place filtering sheet evenly on top of the filtering mesh and gasket.
4. Place the stainless steel gasket on top of the filtering sheet.
5. For an added filtering boost, sprinkle filter powder (sold separately) on top of the mesh and paper.

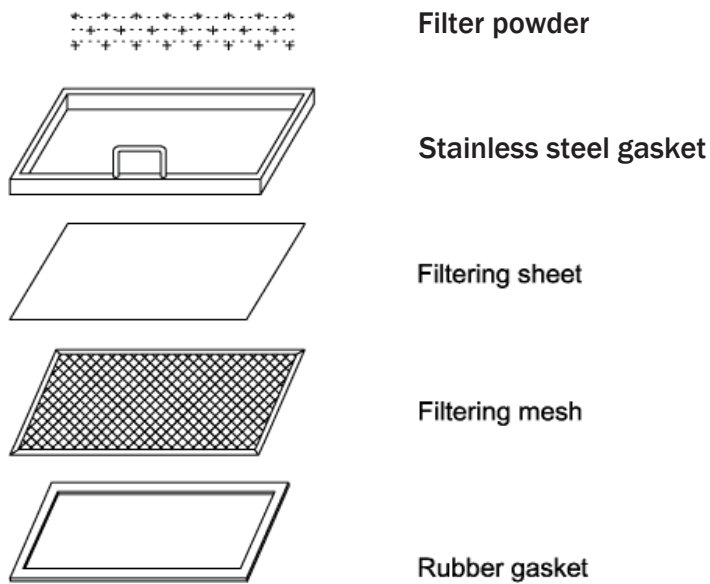

CLEANING - NOTE:

To maintain cleanliness and increase service life, this item should be cleaned daily.

Do not immerse the unit in water or any other liquid. If liquid enters the electrical compartment, it may cause a short circuit or electrical shock.

1. Before cleaning or attempting to move this item, turn off, unplug, and let the unit cool completely.
2. Wipe the entire unit with a clean soft cloth until it is completely dry.
3. To avoid damage to the unit, do not use abrasive cleaners or scouring pads.
4. If soap or chemical cleaners are used, be sure they are completely rinsed away with clean water immediately after cleaning. Chemical residue could damage or corrode the surfaces of the unit.

To avoid serious injury or damage, never attempt to repair or replace a damaged power cord yourself. Contact a professional repair service.

TROUBLESHOOTING

Problem: The power indicator does not light up, and the motor doesn't start after pressing the button.

Possible Causes: Check the connection between the power cord and outlet. If connection is good, then check breaker.

Action: Plug power cord into outlet fully, or switch on the breaker, if off.

Problem: The power indicator lights up, but the motor is not working when the button is pressed.

Possible Causes: The motor is defective.

Action: Replace or fix the motor.

Problem: The oil is not flowing out.

Possible Causes: Either the filtering layer is blocked, the oil tube is leaking, or the pump is defective.

Action: Replace the filtering sheet, reinstall the oil tube, or replace the pump and other needed parts.

Wiring Diagrams

40lb Fryer

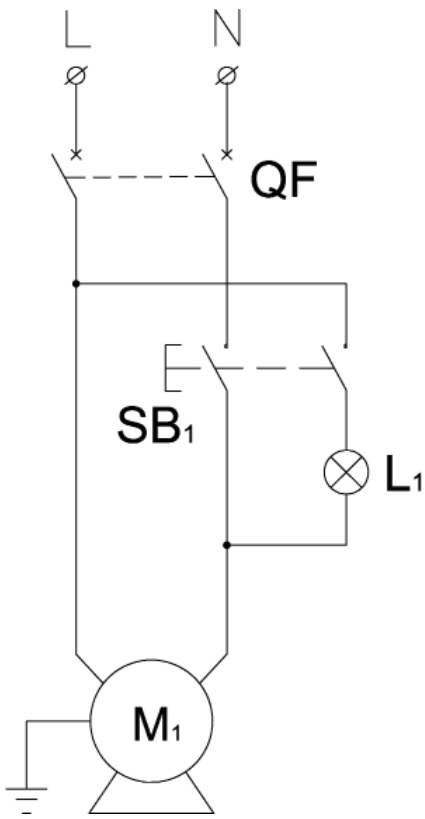

75lb Fryer

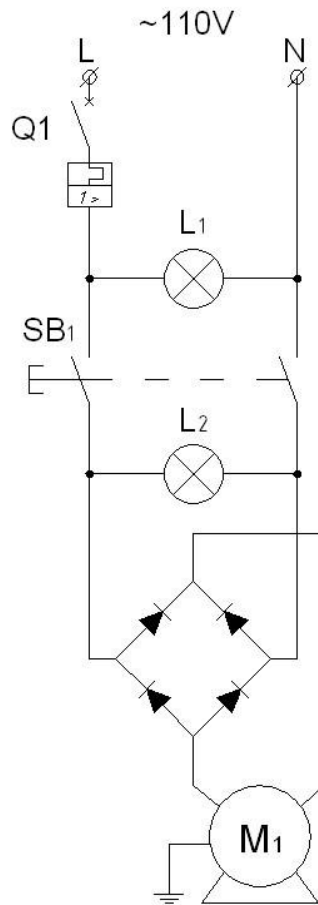

110lb Fryer

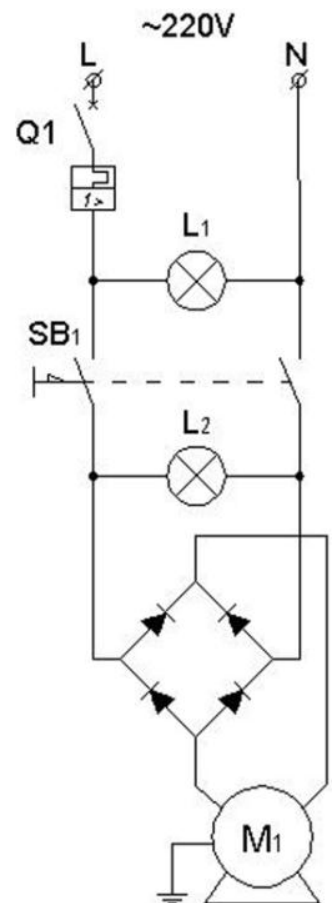

ACE Equipment One Year Limited Warranty

ACE warrants its equipment against defects in materials and workmanship, subject to the following conditions:

ACE Equipment is warranted for one year, effective from the date of purchase by the original owner. A copy of the original receipt or other proof of purchase is required to obtain warranty coverage. This warranty applies to the original owner only, and is not assignable.

Should any product fail to function in its intended manner under normal use within the limits defined in this warranty, at ACE's discretion, such product will be repaired, replaced with a refurbished unit, or replaced with a new unit by ACE, after defective unit has been inspected and defect has been confirmed. ACE does not assume any liability for extended delays in replacing any item beyond its control. This warranty does not apply to rubber and non-metallic synthetic parts that may need to be replaced due to normal usage, wear or lack of preventative maintenance.

This warranty covers products shipped into the 48 contiguous United States. Warranty coverage on products used outside the 48 contiguous United States, Hawaii, Alaska, Puerto Rico, and Canada, cover parts only.

The following conditions are not covered by warranty:

- Equipment failure relating to improper installation, improper utility connection or supply and problems due to improper ventilation.
- Equipment that has not properly been maintained, damage from improper cleaning, and water damage to controls.
- Equipment that has not been used in an appropriate manner, or has been subject to misuse, neglect, abuse, accident, alteration, negligence, damage during transit, delivery or installation, fire, flood, riot, or act of God.
- Equipment that has the model number or serial number removed or altered.
- Equipment on which the security seal has been broken.

If the equipment has been changed, altered, modified, or repaired without express written permission from ACE, then the manufacturer shall not be liable for any damages to any person or to any property, which may result from the use of this equipment thereafter.

This equipment is intended for commercial use only and this warranty is void if equipment is used in other than a commercial application.

For warranty and non-warranty related issues, technical support, please contact NSA at 1-877-672-7740. To purchase replacement parts and warranty registration visit www.admiralcraft.com. Please have your model number, serial number and proof of purchase ready. It is not necessary to contact the place where you originally purchased your product from.

“THE FOREGOING WARRANTY IS IN LIEU OF ANY AND ALL WARRANTIES EXPRESSED OR IMPLIED INCLUDING ANY IMPLIED WARRANTY OF MERCHANTABILITY OR FITNESS FOR PARTICULAR PURPOSES AND CONSTITUTES THE ENTIRE LIABILITY OF ACE. IN NO EVENT DOES THE LIMITED WARRANTY EXTEND BEYOND THE TERMS STATED HEREIN.”

WARRANTY REGISTRATION CARD

MAIL CARD
IMMEDIATELY



This card must be mailed immediately after installation date for warranty to be in effect.

National Service America • 230 Park Ave, 3rd Floor WEST • New York, NY • 10169

_____		_____	
(Name of Business)		(Dealer Purchased From)	

(Address)	(City)	(State)	(Zip Code)
_____		_____	
(Model Number)		(Serial Number)	

This is to inform that I, _____
(Please print name of individual who owns business)

have had the above installed in my place of business _____
(Date of Purchase)

_____	_____	_____
(Contact Phone Number)	(Contact E-mail)	(Signature of Individual Who Owns Business)