

Owner's Manual

CRAFTSMAN®

42" - 2 STAGE SNOW THROWER TRACTOR ATTACHMENT

Model No. 486.248392

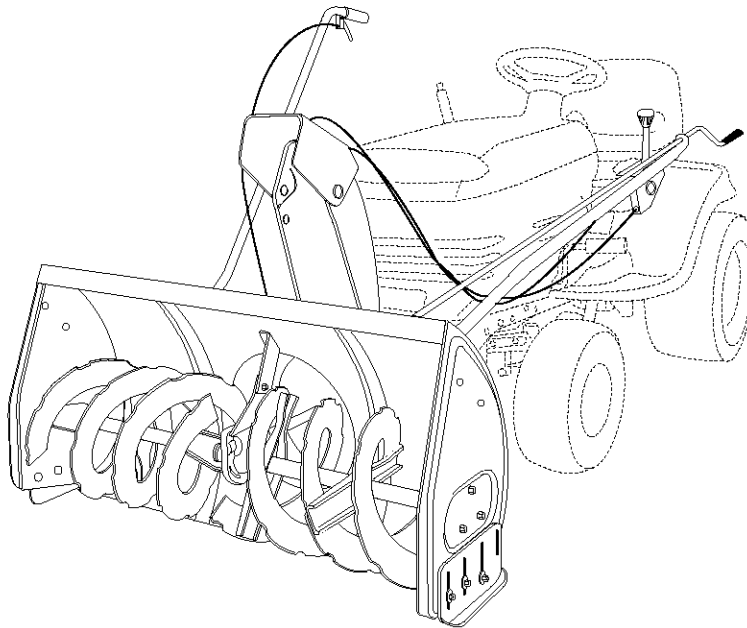

CAUTION:

Before using this product, read this manual and follow all Safety Rules and Operating Instructions.

- Safety
- Assembly
- Operation
- Maintenance
- Parts

IMPORTANT - READ THIS FIRST!!!

For Missing Parts or Assembly Questions

Please Call 217-728-8388

Mon.-Fri. 7 am - 5 pm CST.

FAX 217-728-2032 or e-mail info@agri-fab.com

Missing parts will be sent UPS in 24 hours directly to your home.

Sears, Roebuck and Co., Hoffman Estates, IL 60179 U.S.A.

www.sears.com/craftsman

PRINTED IN U.S.A.

FORM NO. 48936 (6/03)

TABLE OF CONTENTS

ACCESSORIES.....2	SERVICE AND ADJUSTMENTS.....20
SAFETY RULES.....3	STORAGE.....21
FULL SIZE HARDWARE CHART.....4	TROUBLESHOOTING.....21
CARTON CONTENTS.....5	REPAIR PARTS ILLUSTRATION.....22,24
ASSEMBLY.....5	REPAIR PARTS LIST.....23,25
OPERATION.....18	SLOPE GUIDE.....27
MAINTENANCE.....19	PARTS ORDERING/SERVICE.....BACK COVER

WARRANTY

LIMITED ONE YEAR WARRANTY ON 42" 2-STAGE SNOW THROWER

For one year from the date of purchase, when this snow thrower is maintained and lubricated according to the operating and maintenance instructions in the owner's manual, Sears will repair any defect in material or workmanship free of charge. If this snow thrower is used for commercial or rental purposes, this warranty applies for only 90 days from the date of purchase.

This warranty does not cover repairs necessary because of operator negligence or abuse, including the failure to maintain the equipment according to instructions contained in the owner's manual.

WARRANTY SERVICE IS AVAILABLE BY CONTACTING THE NEAREST SEARS SERVICE CENTER/DEPARTMENT IN THE UNITED STATES.

This warranty applies only while this product is in the United States.

This warranty gives you specific legal rights, and you may also have other rights which vary from state to state. Sears, Roebuck and Co. D/817 WA. Hoffman Estates, Chicago, IL 60179

ACCESSORIES AND ATTACHMENTS

These accessories were available when the unit was purchased. They are also available at most Sears retail outlets and service centers. Most Sears stores can order repair parts for you when you provide the model numbers of your tractor and snow thrower.

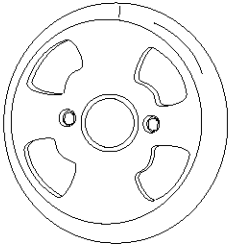
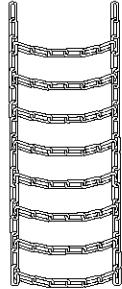
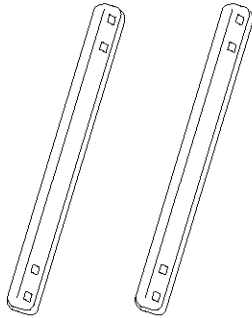
<p>WHEEL WEIGHT</p> 	<p>TIRE CHAINS</p> 	<p>DRIFT CUTTER BARS KIT NO. 71-88294</p> 
----------------------------------------------------------------------------------------------------------------	---------------------------------------------------------------------------------------------------------------	--------------------------------------------------------------------------------------------------------------------------------------------

<p>The model number and serial numbers will be found on a decal attached to the snow thrower.</p> <p>You should record both the serial number and the date of purchase and keep in a safe place for future reference.</p>	<table style="width: 100%; border: none;"> <tr> <td style="border: none;">MODEL NUMBER:</td> <td style="border: none;">486.248392</td> </tr> <tr> <td style="border: none;">SERIAL NUMBER:</td> <td style="border: none;">_____</td> </tr> <tr> <td style="border: none;">DATE OF PURCHASE:</td> <td style="border: none;">_____</td> </tr> </table>	MODEL NUMBER:	486.248392	SERIAL NUMBER:	_____	DATE OF PURCHASE:	_____
MODEL NUMBER:	486.248392						
SERIAL NUMBER:	_____						
DATE OF PURCHASE:	_____						





SAFETY



Any power equipment can cause injury if operated improperly or if the user does not understand how to operate the equipment. Exercise caution at all times, when using power equipment.

- Read this owner's manual carefully and know how to operate your snow thrower and how to stop the unit and disengage the controls quickly.
- Never allow children to operate the equipment.
- Never allow adults to operate the equipment without proper instruction.
- Keep the area of operation clear of all persons, especially small children, and pets.
- Thoroughly inspect the area where the equipment is to be used and remove all door mats, sleds, boards, wires and other foreign objects.
- Disengage all clutches and shift into neutral before starting engine.
- Do not operate equipment without wearing adequate winter outer garments.
- Wear substantial footwear which will protect feet and improve footing on slippery surfaces.
- Check fuel before starting the engine. Do not remove the fuel cap or fill the fuel tank while the engine is running or hot. Do not fill the fuel tank indoors. Gasoline is an extremely flammable fuel.
- Make sure the snow thrower height is adjusted to clear the type surface it will be used on.
- Do not use the snow thrower without the rear weight attached to the tractor.
- Never make any adjustments while the engine is running.
- Always wear safety glasses or eye shield during operation or while performing and adjustment or repair.
- Do not place hand or feet near rotating parts. Keep clear of the discharge opening at all times.
- Use extreme caution when operating on or crossing gravel surfaces.
- Do not carry passengers.
- After striking a foreign object, stop the engine, remove the wire from the spark plug and then thoroughly inspect the snow thrower for damage. Repair any damage before restarting and operating the snow thrower.
- If the snow thrower starts to vibrate abnormally, stop the engine immediately and check for the cause. Vibration is generally a warning of trouble.
- Stop the engine whenever you leave the operating position, before unclogging the snow thrower or making any adjustments or inspections.
- Take all possible precautions when leaving the unit unattended. Disengage the attachment clutch lever or switch, lower the snow thrower, shift into neutral, set the parking brake, stop the engine and remove the key.
- When cleaning, repairing or inspecting, make certain all moving parts have stopped. Disconnect the spark plug wire and keep it away from the plug to prevent accidental starting.
- Do not run engine indoors except when transporting the snow thrower in or out of the building. Open the outside doors. Exhaust fumes are dangerous.
- Do not clear snow across the face of slopes. Exercise extreme caution when changing direction on slopes. Do not attempt to clear steep slopes. Refer to the slope guide on page 27 of this manual.
- Never operate the snow thrower without guards, plates or other safety protection devices in place.
- Never operate the snow thrower near glass enclosures, automobiles, window wells, drop offs etc. without proper adjustment of the snow thrower discharge angle.
- Never direct discharge at bystanders or allow anyone in front of the snow thrower.
- Never run the snow thrower into material at high speeds.
- Do not overload the machine capacity by attempting to clear snow at too fast a rate.
- Never operate the machine at high transport speed on slippery surfaces. Look behind and use care when backing.
- Watch for traffic and stay alert when crossing or operating near roadways.
- Disengage power to the snow thrower when transporting or when not in use.
- Use only attachments and accessories approved by the manufacturer of the snow thrower (such as wheel weights, counter weights, cabs etc.)
- Never operate the snow thrower without good visibility or light.



Look for this symbol to point out important safety precautions. It means--**Attention!! Become alert!! Your safety is involved.**

HARDWARE PACKAGE CONTENTS

SHOWN ACTUAL SIZE

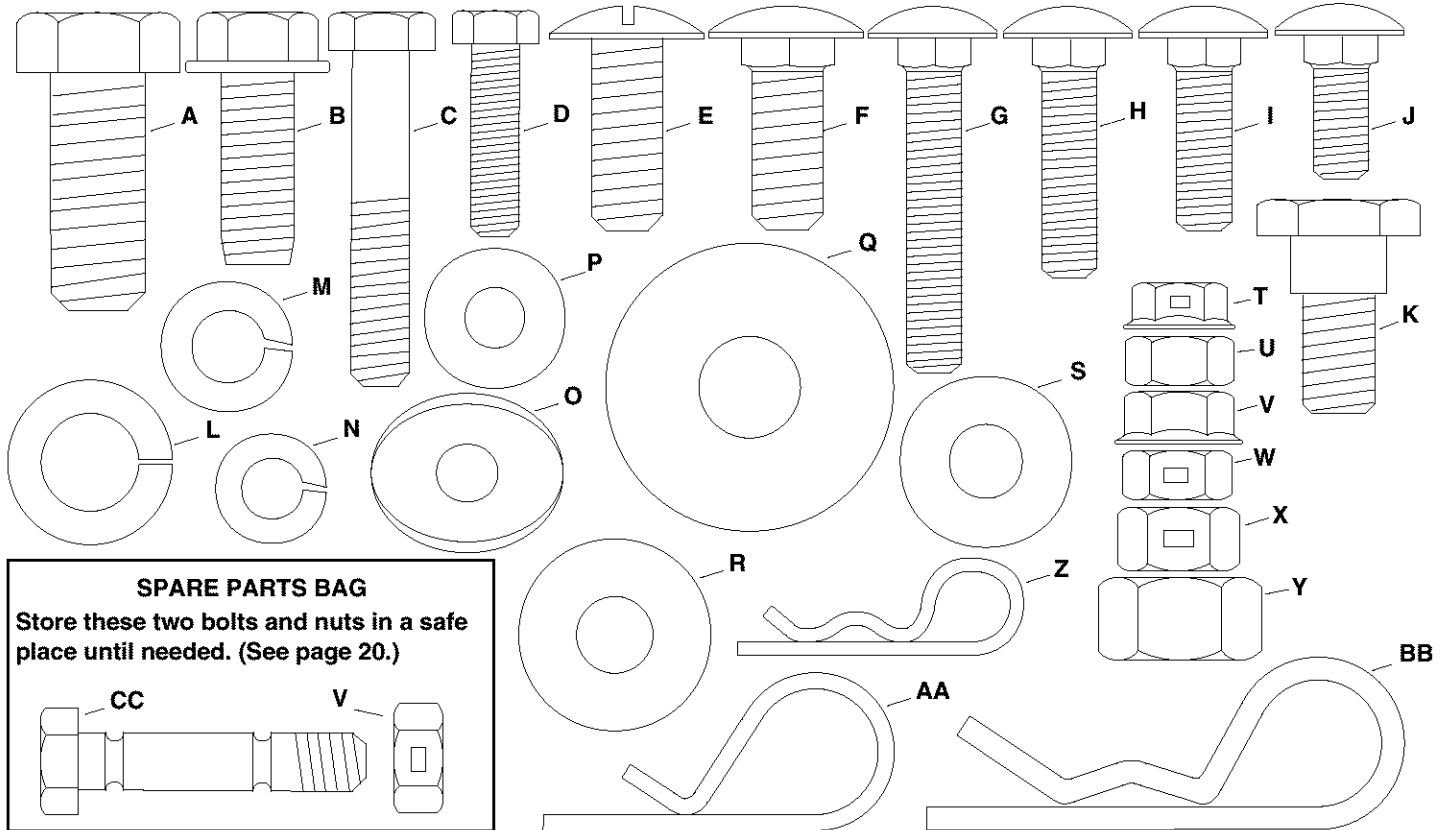

SPARE PARTS BAG

Store these two bolts and nuts in a safe place until needed. (See page 20.)

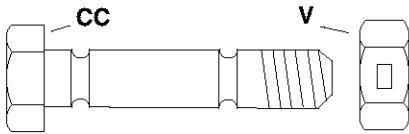

NOT SHOWN ACTUAL SIZE

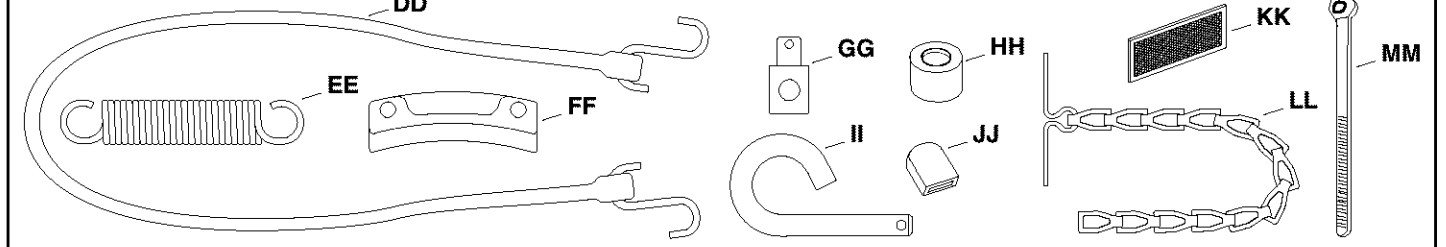

REF.	QTY.	DESCRIPTION	REF.	QTY.	DESCRIPTION
A	1	Hex Bolt, 1/2" x 1-1/4"	T	6	Hex Lock Nut, 1/4"
B	4	Hex Bolt, 3/8" x 1" (Thread Forming)	U	12	Hex Nut, 5/16"
C	2	Hex Bolt, 5/16" x 1-3/4"	V	1	Whizlock Nut, 5/16"
D	6	Hex Bolt, 1/4" x 1"	W	4	Hex Lock Nut, 5/16" (2 pcs. spare parts)
E	2	Slotted Truss Head Bolt, 3/8" x 1"	X	11	Hex Lock Nut, 3/8"
F	4	Carriage Bolt, 3/8" x 1"	Y	1	Hex Nut, 1/2"
G	2	Carriage Bolt, 5/16" x 1-3/4"	Z	3	Hairpin Cotter, 5/64"
H	2	Carriage Bolt, 5/16" x 1-1/4"	AA	1	Hairpin Cotter, 3/32"
I	6	Carriage Bolt, 5/16" x 1"	BB	3	Hairpin Cotter, 1/8"
J	2	Carriage Bolt, 5/16" x 3/4"	CC	2	Shear Bolt (spare parts)
K	4	Shoulder Bolt, 3/8" x 5/8"	DD	1	Tarp Strap
L	1	Lock Washer, 1/2"	EE	1	Spring
M	10	Lock Washer, 3/8"	FF	3	Chute Keeper
N	14	Lock Washer, 5/16"	GG	1	Trunnion
O	2	Bowed Washer	HH	1	Spacer
P	7	Washer, 1/4"	II	2	Lock Pin
Q	2	Washer, 1/2"	JJ	1	Plastic Cap
R	1	Washer, 3/8"	KK	2	Tail Reflector
S	2	Washer, 5/16"	LL	1	Chain, Tensioning
			MM	2	Nylon Tie

ASSEMBLY

CARTON CONTENTS

1. Cross Brace (Weight Tray)
 2. Side Brace (Weight Tray)
 3. Right Hand Side Plate (Stamped "R")
 4. Left Hand Side Plate (Stamped "L")
 5. Anti-rotation Bracket
 6. Engagement Rod (Not used on some models)
 7. Engine Pulley Keeper (Not used on some models)
 8. Chute Crank Rod Assembly
 9. Support Tube, Crank Rod
 10. Lift Handle Tube and Cable
 11. Cable Bracket
 12. Plastic Keg
 13. Left Hand Hanger Bracket (Stamped "L")
 14. Right Hand Hanger Bracket (Stamped "R")
 15. Clutch Idler Assembly
 16. V Belt, Drive
 17. V Belt, Auger (Attached to Housing Assembly)
 18. Chute and Control Cable Assembly
 19. Housing Assembly
 20. Weight Tray
- Hardware Package (Stored inside Plastic Keg)

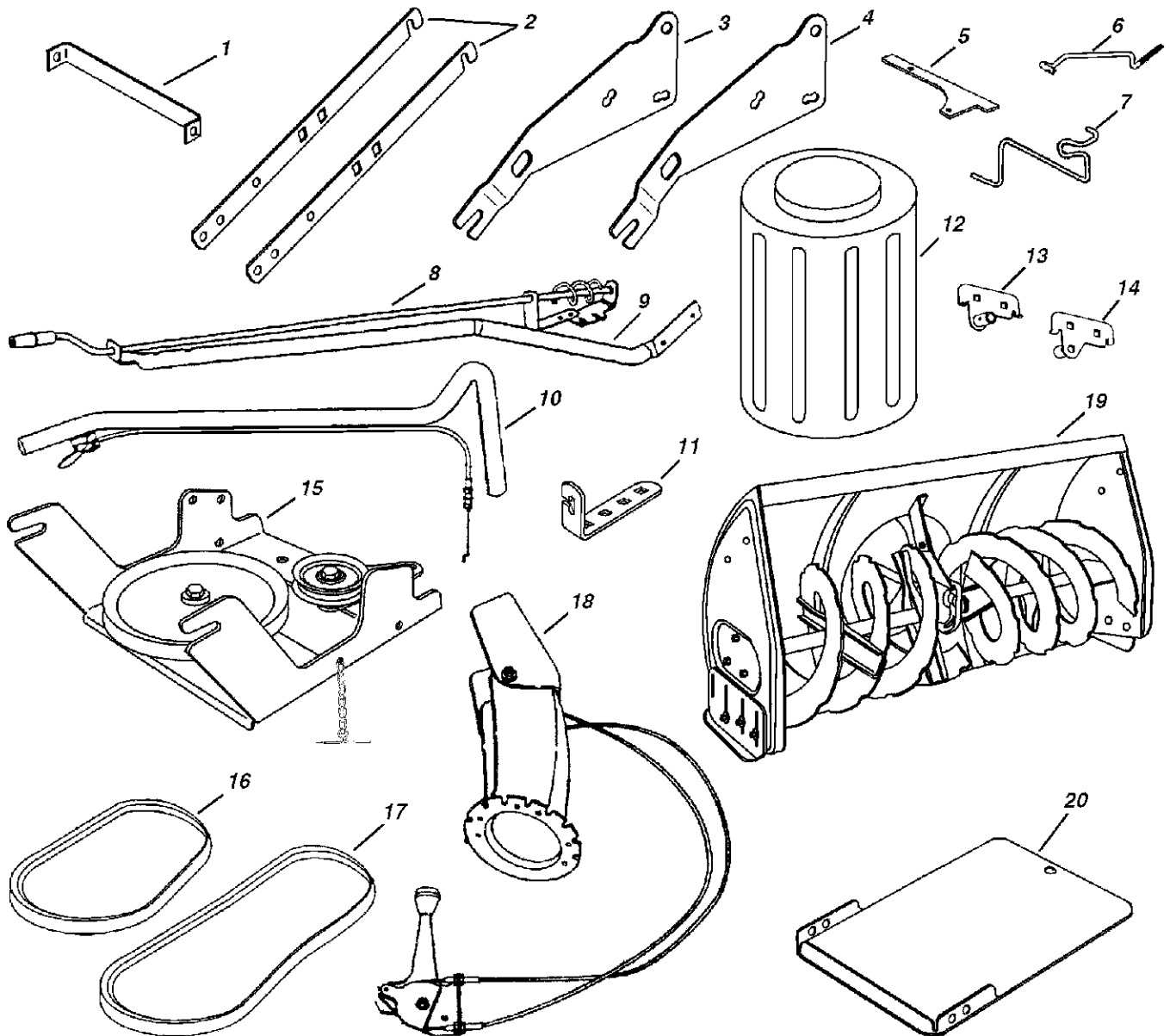

TOOLS REQUIRED FOR ASSEMBLY

- (2) 7/16" Wrenches
- (2) 1/2" Wrenches
- (2) 9/16" Wrenches
- (2) 3/4" Wrenches
- (1) Knife

ADDITIONAL ITEMS REQUIRED
General Purpose Grease

REMOVAL OF PARTS FROM CARTON

- Remove all parts and hardware packages from the carton. Lay out parts and hardware and identify using the illustrations on pages 4 and 5.

NOTE: Not all of the supplied parts and hardware will be needed for your particular tractor. Unneeded items may be discarded after you have completed assembly.



CAUTION: Before starting to assemble the snow thrower, remove the spark plug wire(s), set the parking brake and remove the key from the tractor ignition.

TRACTOR PREPARATION

Before performing these instructions, refer to the Service and Adjustments section of your tractor owner's manual for specific safety instructions.

- Allow engine, muffler and exhaust deflector to cool before beginning.
- Remove any front or rear attachment which is mounted to your tractor.
- Remove the mower deck. Refer to your tractor owner's manual for removal instructions. Mark all loose parts and save for reassembly.
- Remove the tractor hood and grill assembly. Refer to your tractor owner's manual for removal instructions.

ITEMS REMOVED FROM TRACTOR

Store all parts that you remove from the tractor and do not re-use while assembling the snow thrower.

Right hand (R.H.) and left hand (L.H.) side of the tractor are determined from the operators position while seated on the tractor.

INSTALLING SIDE PLATES ON TRACTOR

TRACTORS WITH FRAME MOUNTED FRONT SUSPENSION BRACKETS (See figure 1.)

- Remove any bolts that are present in the two holes shown as empty in figure 1.
- If there is a bolt in the third hole shown in figure 1, remove the nut and washer but leave the bolt in place.

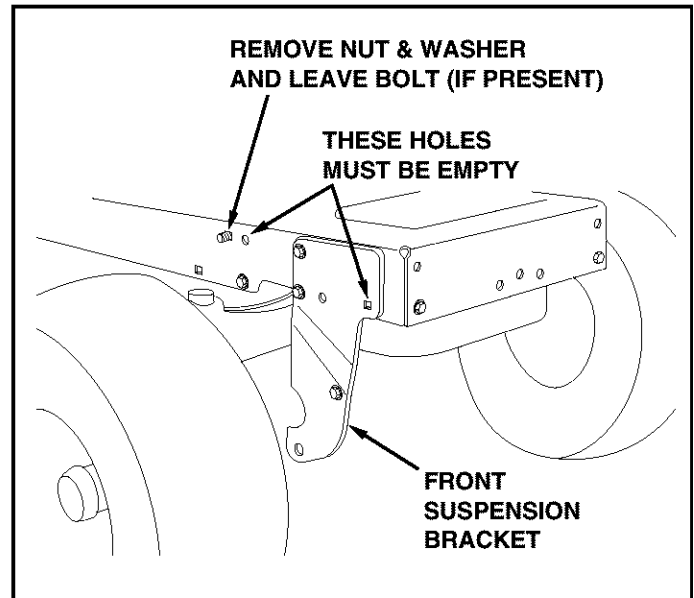

FIGURE 1

RIGHT SIDE VIEW

- Assemble the R.H. Side Plate (marked "R") to the two now empty holes in the side of the tractor frame. Use two 3/8" x 1" hex bolts and 3/8" lock washers as shown in figure 2. Repeat for the L.H. side.
- If you removed a nut and washer from the bolt in figure 1, assemble a whizlock nut onto the bolt.

NOTE: If you remove the side plates, be sure to reassemble all bolts to tractor frame .

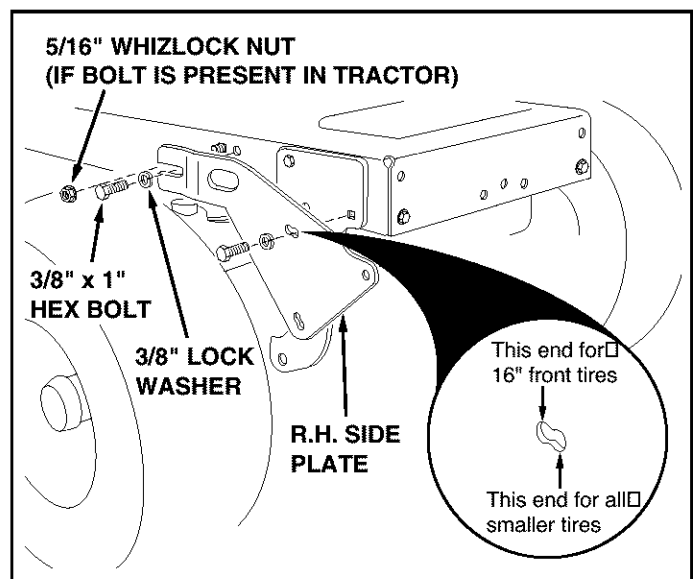

FIGURE 2

RIGHT SIDE VIEW

- Assemble a shoulder bolt, a 3/8" lock washer and a 3/8" hex lock nut to the bottom hole in each side plate. See figure 3.
- Proceed to page 8.

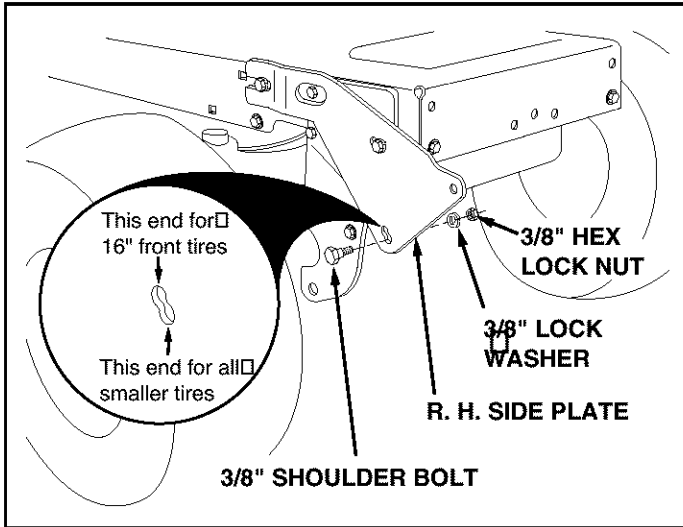

FIGURE 3 **RIGHT SIDE VIEW**

IMPORTANT: If you remove the side plates, be sure to reassemble all bolts to tractor frame .

- Attach the R.H. Side Plate (marked "R") to the right side of the tractor frame as shown in figure 5. For the front hole use a 3/8" x 1" hex bolt, a 3/8" lock washer, and a 1/2" flat washer. Use the flat washer as a shim between the frame and the side plate. For the rear hole use a 3/8" x 1" hex bolt, and a 3/8" lock washer. Repeat for the L.H. side.

NOTE: If the bolt inserts freely into the front hole, the 3/8" lock washer along with a 3/8" hex lock nut must be assembled onto the bolt from inside the tractor frame.

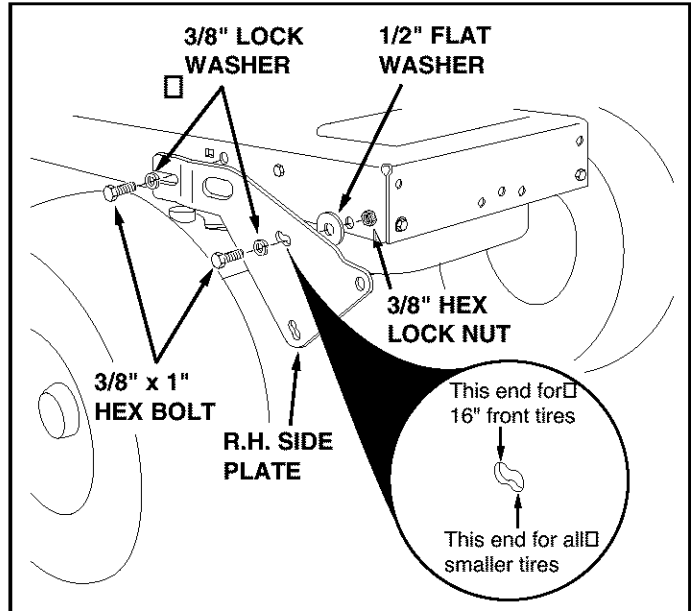

FIGURE 5 **RIGHT SIDE VIEW**

TRACTORS WITH AXLE MOUNTED FRONT SUSPENSION BRACKETS

- Remove any bolts present in the holes shown in figure 4 on both sides of the tractor frame.

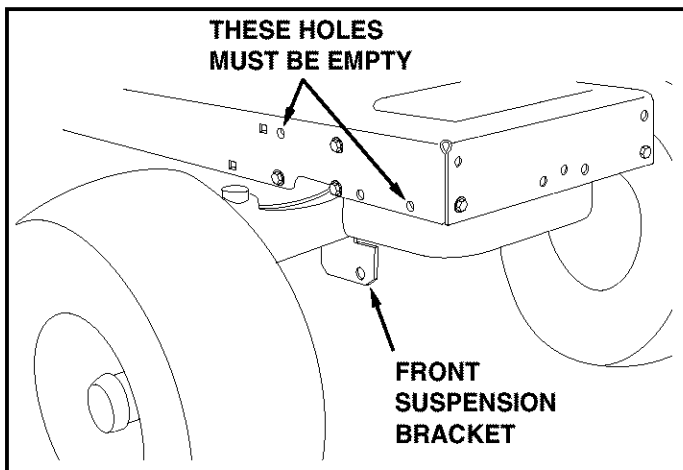

FIGURE 4 **RIGHT SIDE VIEW**

- Assemble a shoulder bolt, a 3/8" lock washer and a 3/8" hex lock nut to the bottom hole in each side plate. See figure 6.

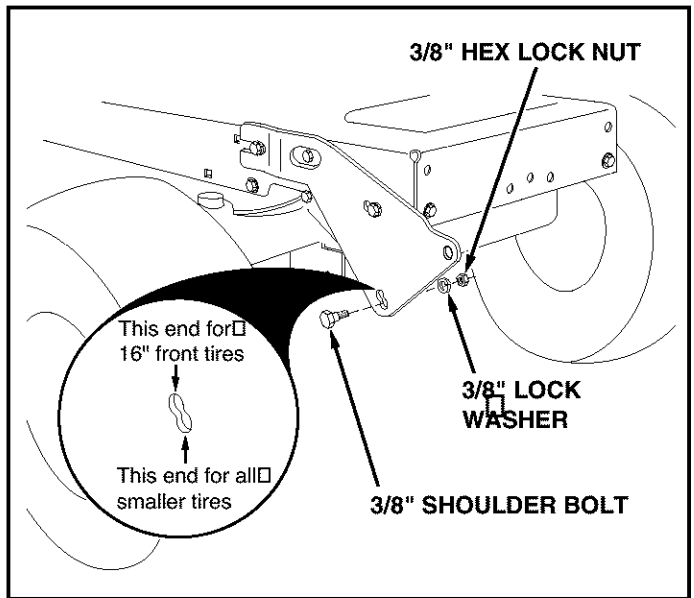

FIGURE 6 **RIGHT SIDE VIEW**

IMPORTANT: If you remove the side plates, be sure to reassemble all bolts to tractor frame .



INSTALLING HANGER BRACKETS

For better clearance, lower the tractor's suspension arms using the attachment lift lever.

On Tractors With Foot Rest Brackets (Figure 7)

- Remove the bolt and nut that fasten the L.H. and R.H. foot rest brackets to the frame. See figure 7.
- Attach the L.H. Hanger Bracket (marked "L") to the inside of the tractor frame using two 3/8" x 1" carriage bolts, 3/8" lock washers and 3/8" hex lock nuts. The bolt heads go on the inside of the tractor frame. Repeat for the R.H. side. See figure 7.

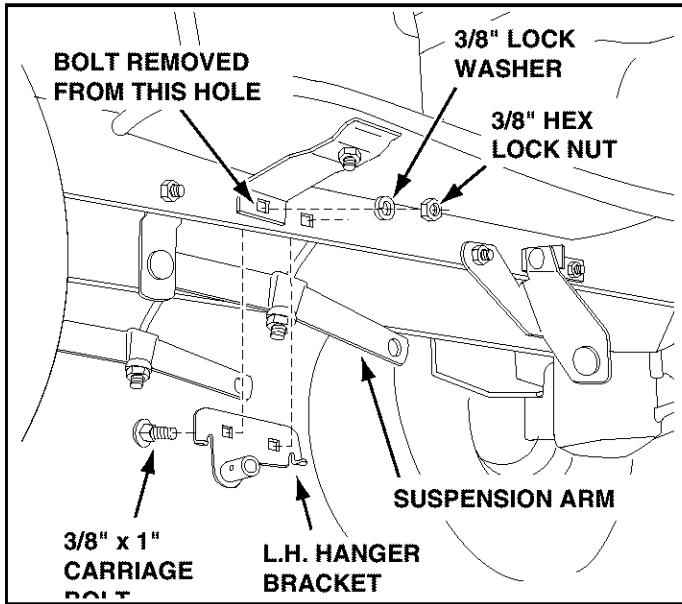

FIGURE 7 LEFT SIDE VIEW

On Tractors Without Foot Rest Brackets (Figure 8)

- Find the empty hole beneath the foot rest. Attach the L.H. Hanger Bracket (marked "L") to the inside of the frame using a 3/8" x 1" carriage bolt (head to inside), a 3/8" lock washer and a 3/8" hex lock nut. See figure 8. Repeat for the R.H. side.

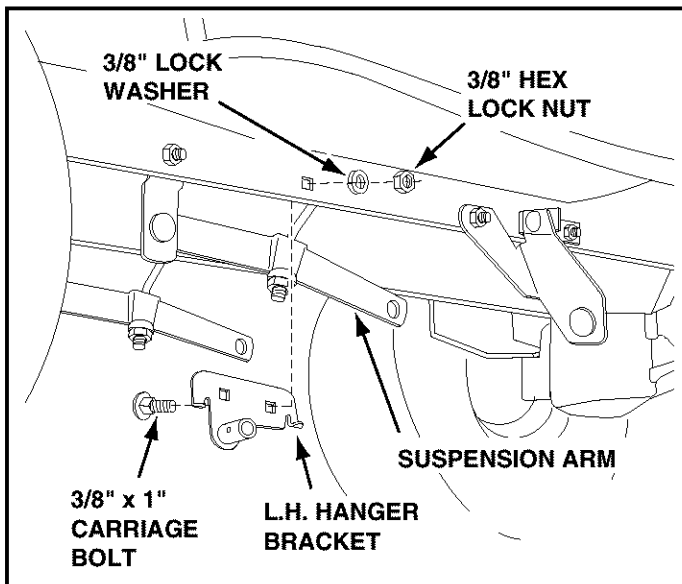

FIGURE 8 LEFT SIDE VIEW

INSTALLING SHOULDER BOLTS

(All Tractors)

- Remove the bolt, washer and nut which fasten the sway bar bracket to the L.H. side of the tractor frame. Replace with a shoulder bolt and a 3/8" hex lock nut as shown in figure 9.

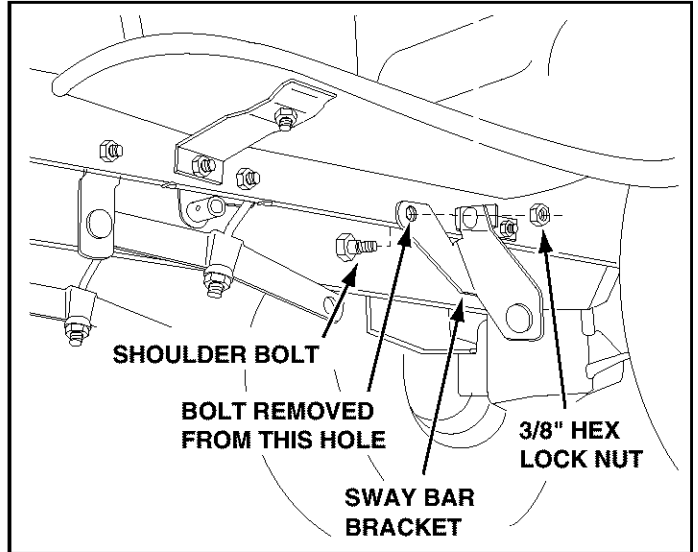

FIGURE 9 LEFT SIDE VIEW

- Assemble a shoulder bolt and 3/8" hex lock nut to the R.H. side of the tractor frame, using the first empty hole to the rear of the R.H. hanger bracket. See figure 10.

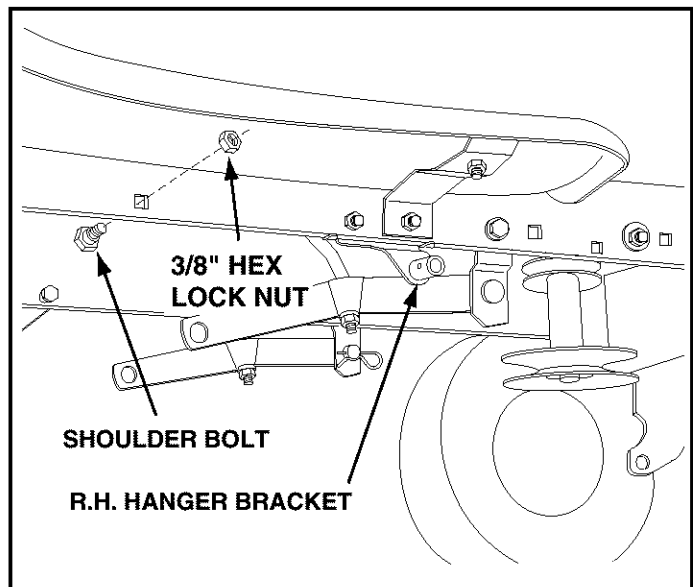

FIGURE 10 RIGHT SIDE VIEW

INSTALLING CLUTCH/IDLER ASSEMBLY

This section covers the installation of the Clutch/Idler assembly to tractors with attachment clutches that are either rod operated (p. 9), cable operated (p. 10) or electric (p. 12). Use the appropriate instructions for your tractor.

MANUAL ROD OPERATED ATTACHMENT CLUTCH

- Move the attachment clutch lever on the dash panel to the disengaged (down) position.
 - Screw the trunnion onto the end of the snow thrower engagement rod as shown in figure 11.
 - Locate the clutch arm (where the mower clutch rod was connected) underneath the right hand side the tractor, just to the inside of the suspension arm. **If there is an extension** attached to the clutch lever, the extension, bolt and nut must be removed and stored with the mower deck.
- IMPORTANT:** Re-attach the extension to the clutch lever before reinstalling the mower deck.
- Position the engagement rod to the inside of the clutch arm and insert the drilled end of the rod through the arm. Secure with a 5/64" hairpin cotter. See figure 11.

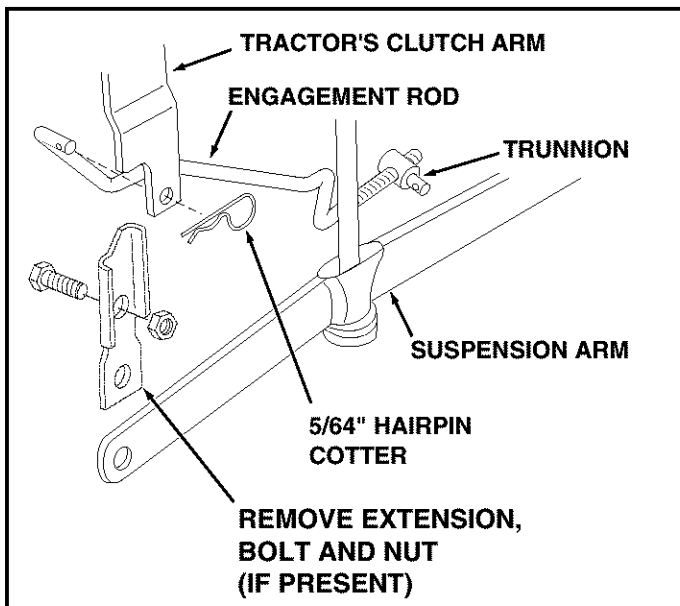

FIGURE 11 RIGHT SIDE VIEW

- Be sure to lift up the front end of the engagement rod (as shown in figure 12) when performing the next operation. You can temporarily support the rod using a rubber band tied to the engine pulley keeper.
- Attach the clutch/idler assembly to the tractor frame as follows. Hook the assembly's notched arms onto the two shoulder bolts you assembled to the inside of the tractor frame. Lift the front of the assembly and attach it to the R.H. and L.H. hanger brackets using two pivot lock pins and 1/8" hairpin cotters. See figure 12.

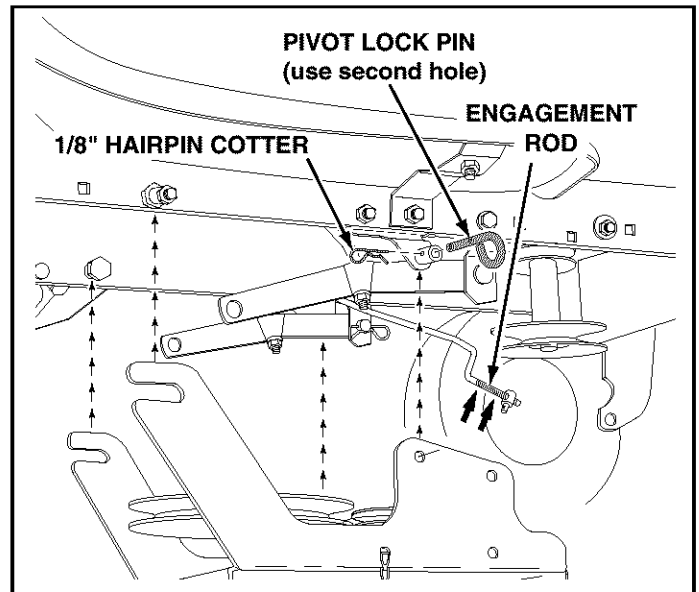

FIGURE 12 RIGHT SIDE VIEW

- Make sure the attachment clutch lever on the dash panel is in the disengaged (down) position.
 - Pivot the upper idler arm so that it rests against the stop bolt and is pointing toward the front as shown in figure 13. Screw the trunnion along the threads of the engagement rod until it is aligned at the front end of the idler arm slot. Attach the trunnion to the slot using the 3/8" flat washer and a 5/64" hairpin cotter. See figure 13.
 - Remove the engine pulley keeper from the side of the tractor frame by removing the washer and nut that secure the keeper. Attach the new pulley keeper supplied with the snow thrower, reusing the original bolt, washer and nut. See figure 13.
- NOTE:** Some tractors may already be equipped with an identical pulley keeper.

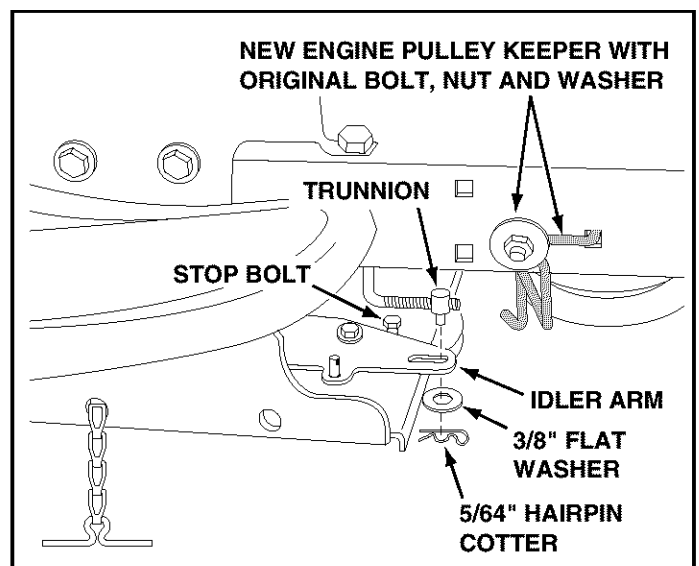

FIGURE 13 RIGHT SIDE VIEW

- Assemble the short "V" belt onto the engine pulley and then onto the large pulley on top of the clutch/idler assembly. The belt must be placed to the inside of the engine pulley keeper, the idler pulley and the keeper bolt located beside the large pulley. See figure 14.

IMPORTANT: Do Not assemble the "V" belt around the outside of the engine pulley keeper or the keeper bolt.

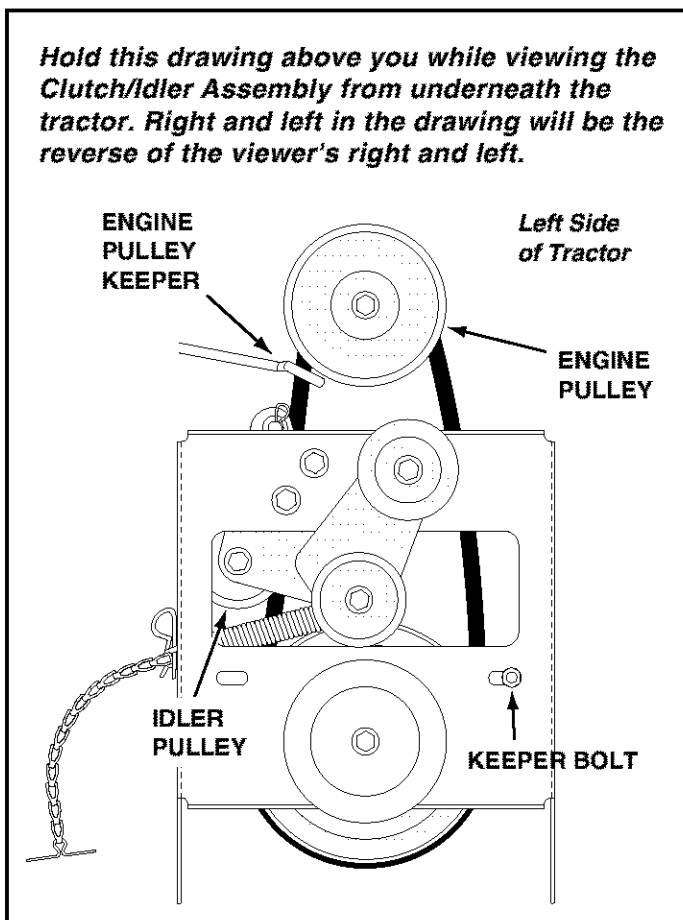

FIGURE 14 VIEWED FROM UNDERNEATH

- Proceed to page 13.

MANUAL CABLE OPERATED ATTACHMENT CLUTCH

- Assemble the cable bracket to the clutch/idler assembly using two 5/16" x 3/4" carriage bolts, 5/16" lock washers and 5/16" hex locknuts. Use the two front holes in the cable bracket if your tractor has a 42" mower deck. Use the two rear holes if your tractor has a 46" mower deck. See figure 15.

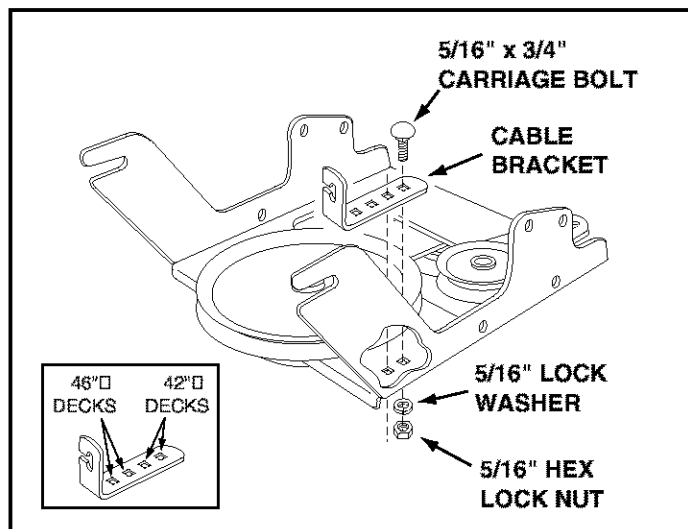

FIGURE 15

- Move the attachment clutch lever on the dash panel to the disengaged (down) position.
- Lay the clutch/idler assembly beneath the tractor.
- Attach the tractor's clutch cable to the cable bracket. Secure the cable housing guide (groove down) to the cable bracket using the original collar and retainer spring removed from the mower deck. See figure 16.
- Place a spacer on the welded pin on the idler arm. Hook the end of the clutch spring over the pin and secure it with a 1/4" washer and a 5/64" hair cotter pin. See figure 16.

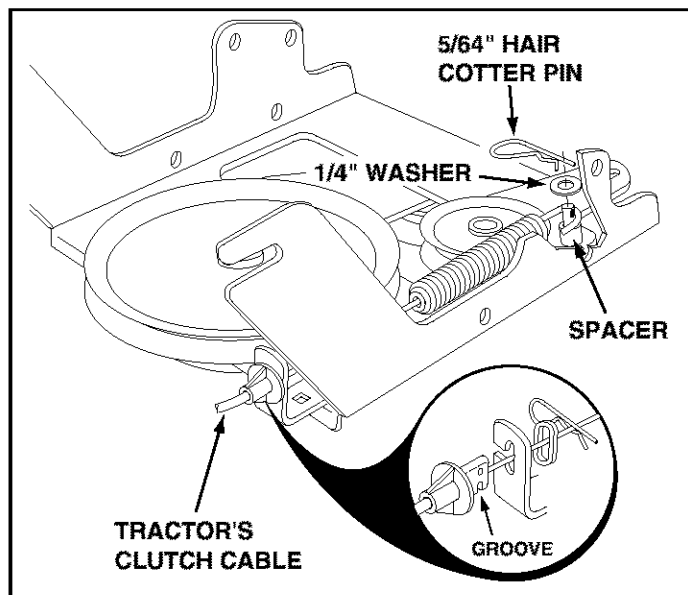

FIGURE 16

- Remove the engine pulley keeper from the side of the tractor frame by removing the washer and nut that secure the keeper. Attach the new pulley keeper supplied with the snow thrower, reusing the original bolt, washer and nut. See figure 17.
NOTE: Some tractors may already be equipped with an identical pulley keeper.
- Attach the clutch/idler assembly to the tractor frame as follows. Hook the assembly's notched arms onto the two shoulder bolts you assembled to the inside of the tractor frame. Lift the front of the assembly and attach it to the R.H. and L.H. hanger brackets using two pivot lock pins and 1/8" hairpin cotters. See figure 17.

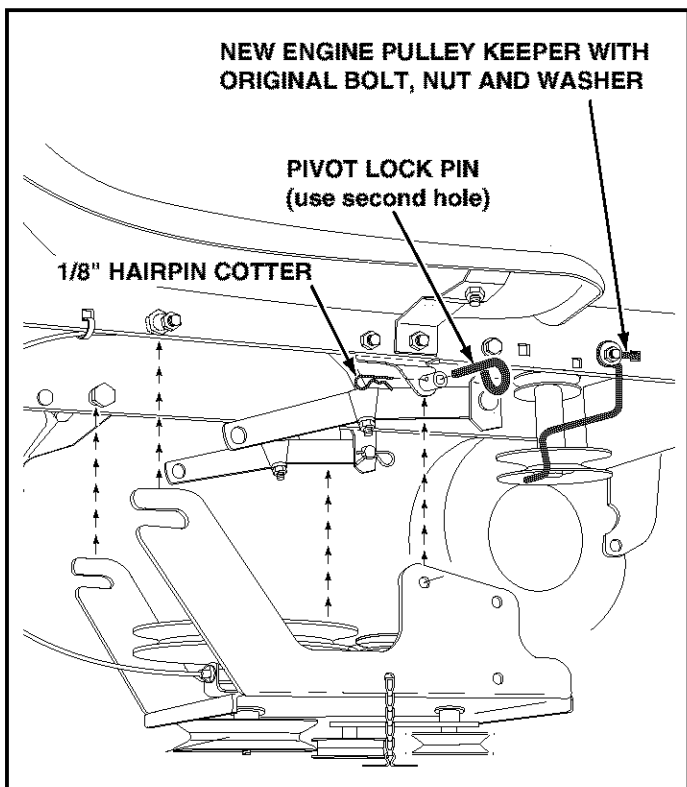

FIGURE 17

- Assemble the short "V" belt onto the engine pulley and then onto the large pulley on top of the clutch/idler assembly. The belt must be placed to the inside of the engine pulley keeper, the idler pulley and the keeper bolt located beside the large pulley. See figure 18.

IMPORTANT: Do Not assemble the "V" belt around the outside of the engine pulley keeper or the keeper bolt.

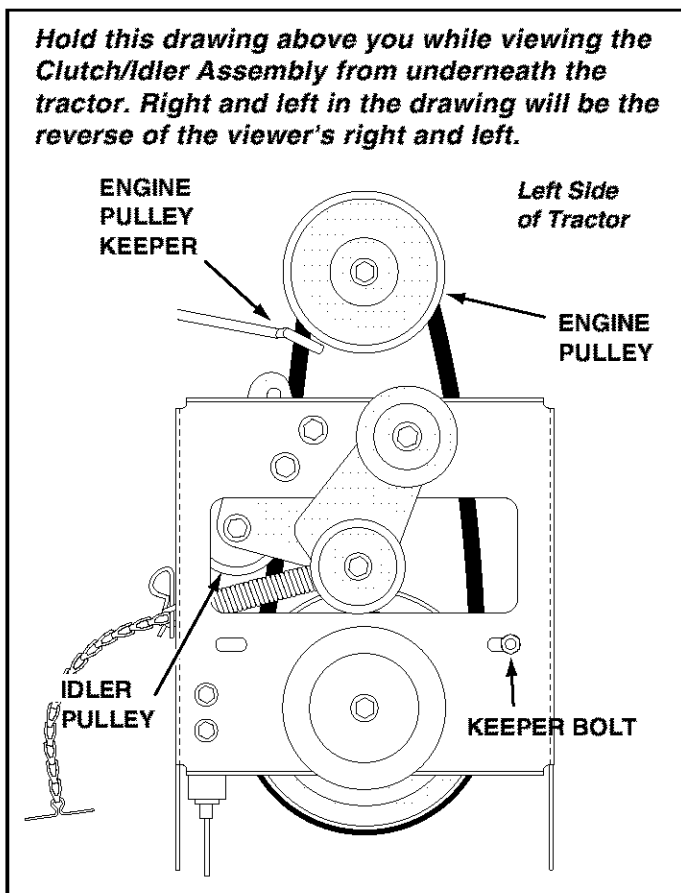

FIGURE 18 VIEWED FROM UNDERNEATH

- Proceed to page 13.

ELECTRIC ATTACHMENT CLUTCHES

- Turn the clutch/idler assembly upside down and place the extra tensioning chain through the left front hole as shown in figure 19.

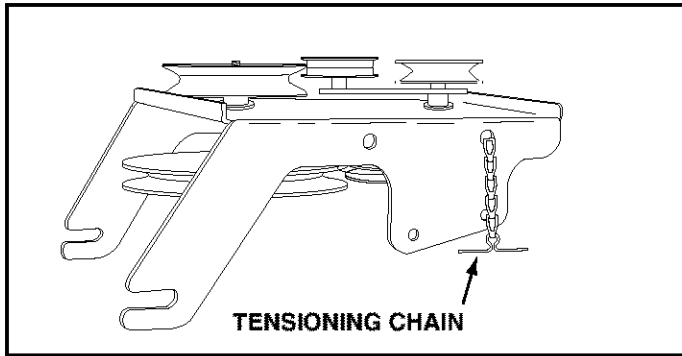

FIGURE 19

- Hook the loose spring through the end of the tensioning chain. See figure 20.
- Hook the other end of the spring onto the bottom of the bolt and nut which secure the idler pulley to the upper idler arm. Hold the bolt head and assemble a 3/8" hex lock nut onto the bolt, leaving it loose enough for the spring to pivot freely between the two nuts. See figure 20.
- Attach a 3/32" hairpin cotter to the chain, placing it in the fifth link from the spring. See figure 20.

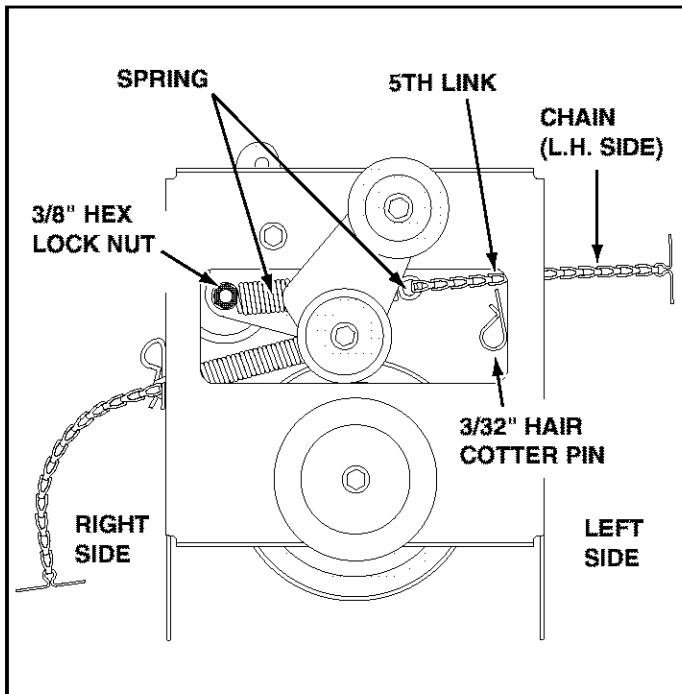

FIGURE 20

VIEW OF BOTTOM

- Attach the clutch/idler assembly to the tractor frame as follows. Hook the assembly's notched arms onto the two shoulder bolts you assembled to the inside of the tractor frame. Lift the front of the assembly and attach it to the R.H. and L.H. hanger brackets using two pivot lock pins and 1/8" hairpin cotters. See figure 21.

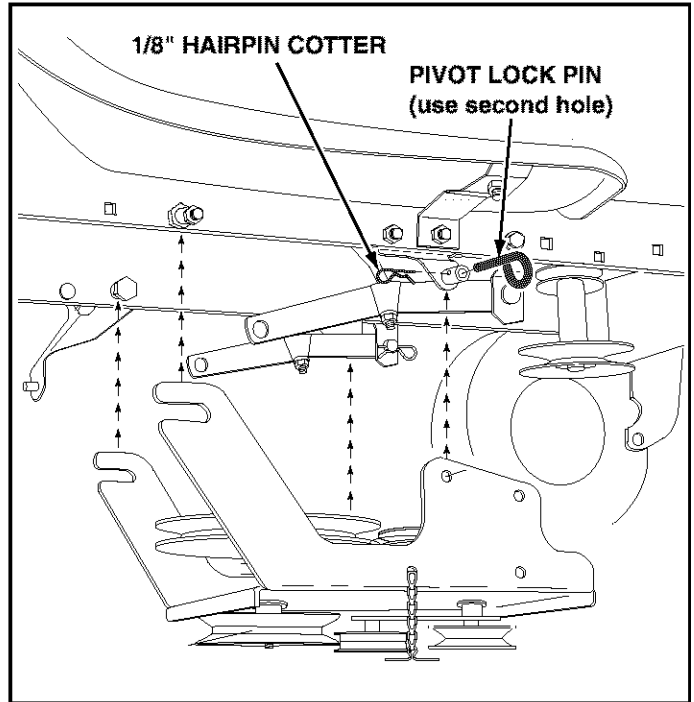

FIGURE 21

RIGHT SIDE VIEW

- Assemble the short "V" belt onto the engine pulley and then onto the large pulley on top of the clutch/idler assembly. The belt must be placed to the inside of the engine pulley keeper, the idler pulley and the keeper bolt located beside the large pulley. See figure 22 on page 13.
- Place tension on the belt by pulling the left side tensioning chain out as far as the 5/64" hairpin cotter will allow. Secure the chain in this position by inserting a 1/8" hairpin cotter through the chain. See figure 22 on page 13.

IMPORTANT: Do Not assemble the "V" belt around the outside of the engine pulley keeper or the keeper bolt.

Hold this drawing above you while viewing the Clutch/Idler Assembly from underneath the tractor. Right and left in the drawing will be the reverse of the viewer's right and left.

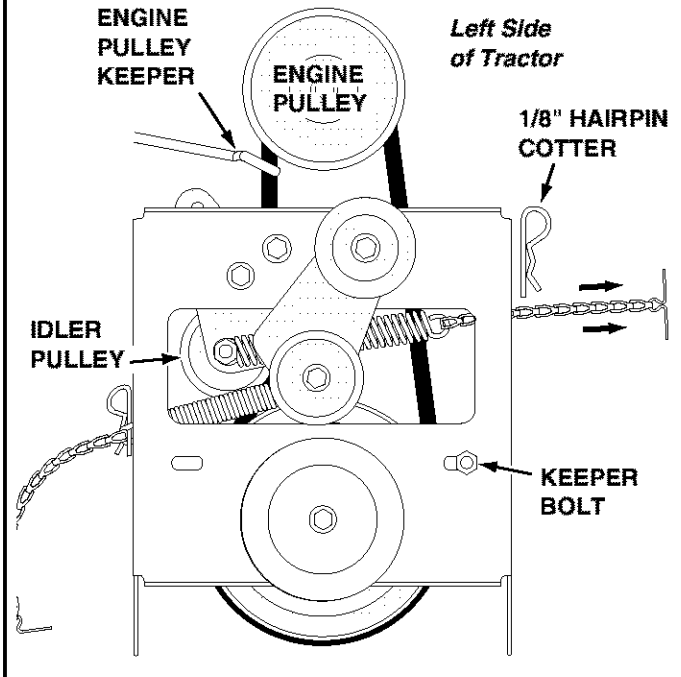

FIGURE 22 VIEWED FROM UNDERNEATH

ASSEMBLY OF THE SNOW THROWER

- Place the lift handle into the lift bracket on the right side of the snow thrower. Fasten the handle to the bracket using two 5/16" x 1-3/4" hex bolts, 5/16" lock washers and 5/16" hex nuts. See figure 23.

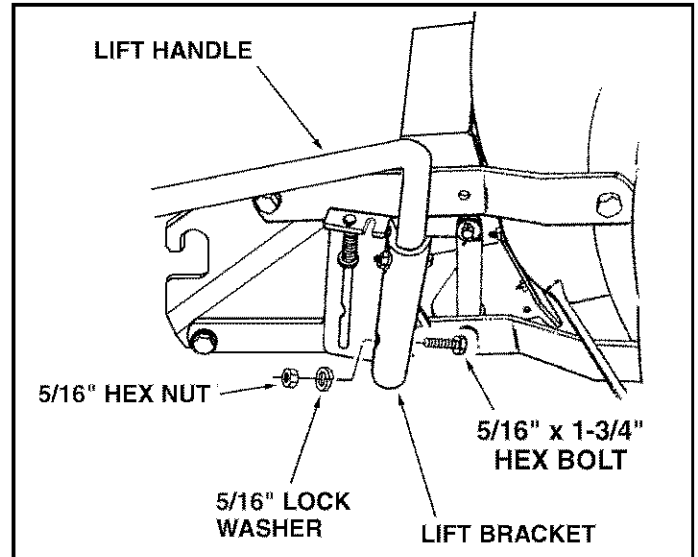

FIGURE 23 RIGHT SIDE VIEW

NOTE: Be sure the lift release cable's plastic covering remains inserted into the trigger assembly while performing the next step.

- Push the lift handle down into the locked position. Insert the end of the cable wire into the hole in the lift rod. Place the threaded fitting into the slot in the lift bracket, with one hex nut above and one hex nut and the lock washer below the slot. Tighten the nuts, adjusting them to eliminate slack in the cable wire. See figure 24. Refer also to the Service and Adjustments section on page 20 in this manual.

HINT: For easier assembly of the lift release cable, tilt the snow thrower forward onto the spiral auger.

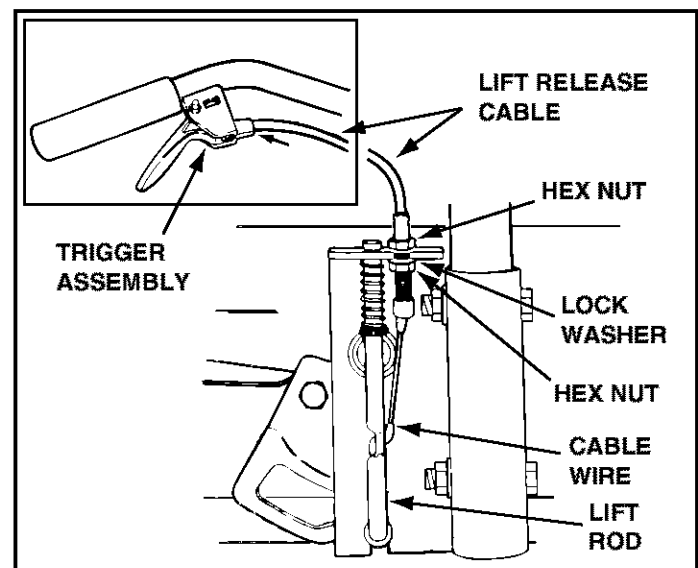

FIGURE 24 RIGHT SIDE VIEW

- Tilt the snow thrower back down to the ground.
- Remove the nylon tie which fastens the auger drive belt to the discharge housing, leaving the belt assembled around the pulleys.
- Remove the nylon tie which fastens the chute crank rod to the crank rod support tube.
- Assemble the crank rod support tube to the bracket on the left side of the thrower housing using two 5/16" x 1-1/4" carriage bolts, 5/16" lock washers and 5/16" hex nuts. See figure 25.

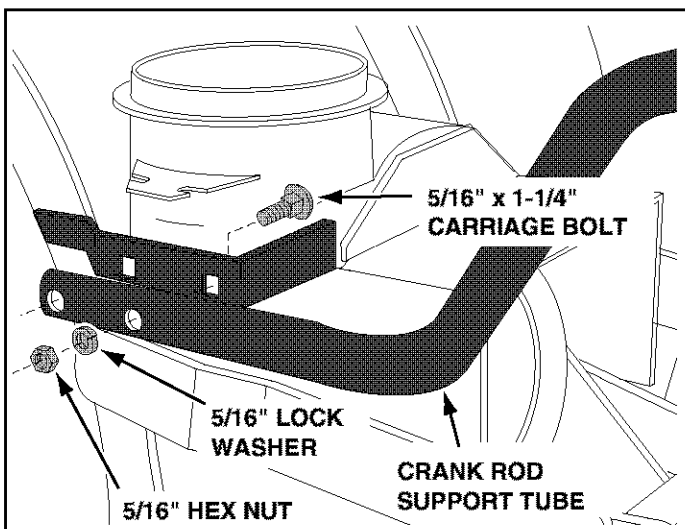

FIGURE 25 LEFT SIDE VIEW

- Attach the chute tilt control assembly to the top side of the crank support tube using two 5/16" x 1-3/4" carriage bolts, bowed washers, 5/16" lock washers and 5/16" hex nuts. See figure 26.

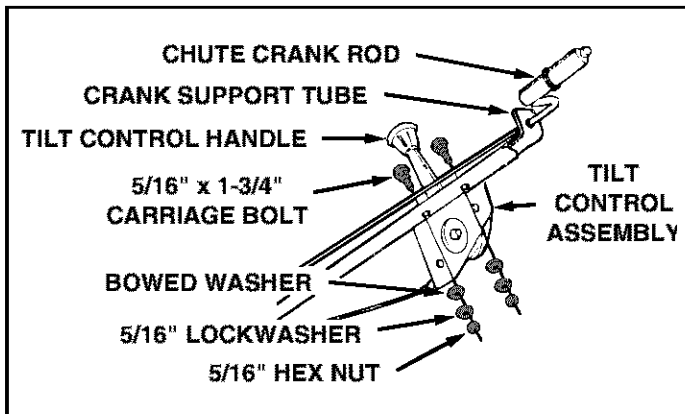

FIGURE 26 LEFT SIDE VIEW

- Attach the chute crank rod assembly brackets to the plastic bracket on the left side of the thrower housing. Align the chute crank bracket beneath the rod support bracket and assemble both to the plastic bracket using two 5/16" x 1" carriage bolts, 5/16" flat washers, 5/16" lock washers and 5/16" hex nuts. **Do not tighten yet.** See figure 27.

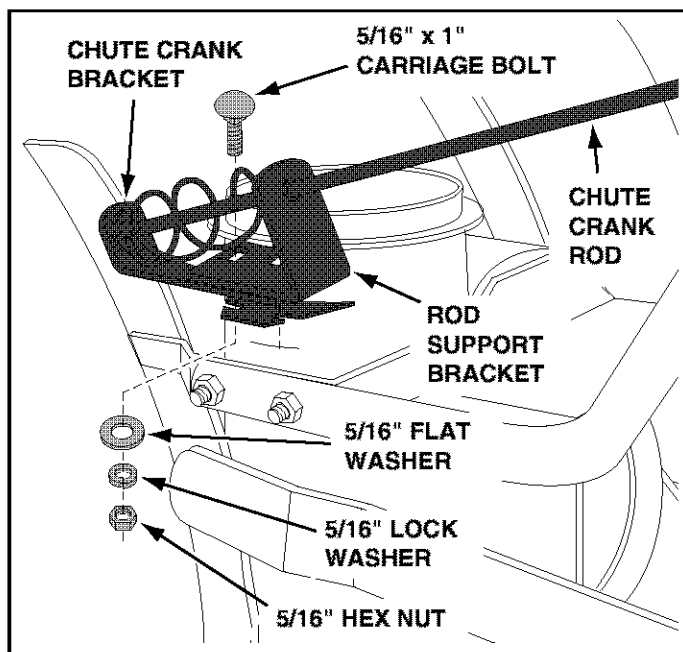

FIGURE 27 LEFT SIDE VIEW

- Coat the top of the ring around the discharge opening with general purpose grease. See figure 28.
- Place the discharge chute (facing forward) onto the ring. Place the anti-rotation bracket on top of the chute flange, aligning it with the holes on the right hand side of the flange. Attach the three chute keepers (right side up as shown) to the bottom of the flange using six 1/4" x 1" hex bolts, 1/4" flat washers and 1/4" hex lock nuts. **Tighten carefully** so that the nuts are snug but do not dig into the plastic chute keepers. See figure 28.
- Place the plastic cap onto the short end of the anti-rotation bracket. See figure 28.
- Position the crank rod spiral so that it does not rub against the bottoms of the notches in the chute flange. **Tighten** the nuts. See figure 27.
- Check if the crank rod rotates the chute freely. If not, loosen by 1/4 turn each of the six hex bolts holding the chute keepers to the chute flange.
- Secure the control cables to the crank rod support tube using a nylon tie.

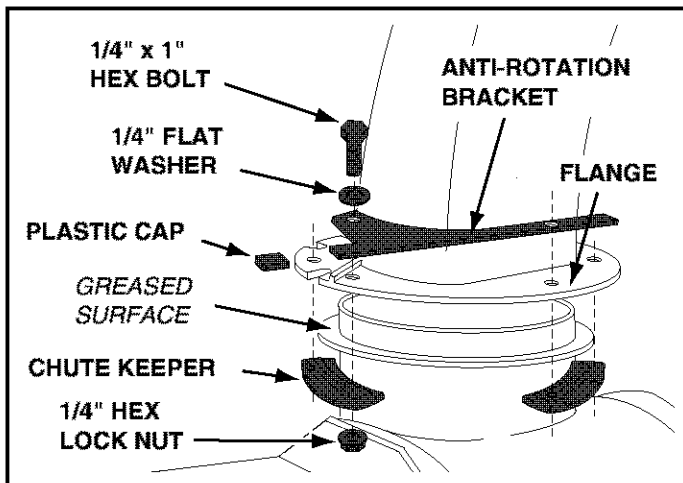

FIGURE 28 RIGHT SIDE VIEW

ATTACHING SNOW THROWER TO TRACTOR

NOTE: An additional person's help may be required to mount the snow thrower to the front of the tractor.

- Place the tractor and snow thrower on a flat, level surface so that the tractor can be rolled forward to attach the snow blower.
- Remove the Attachment Pin from the snow thrower.
- Extend the belt out behind the snow thrower, making sure the belt is still looped over the top of the large drive pulley and underneath the two idler pulleys. The "V" side of the belt must be seated in the grooves of all three pulleys.
- Roll the tractor up behind the snow thrower, centering it between the snow thrower's mounting plates.
- Raise the rear of the snow thrower by lifting up on the lift handle until the notches in the mounting plates align with the shoulder bolts in the tractor's side plates. Guide the bolts into the notches.
- To ease the assembly of the auger drive belt, delay the installation of the attachment pin shown in figure 29 until you have assembled the belt as instructed for figures 30 and 31.

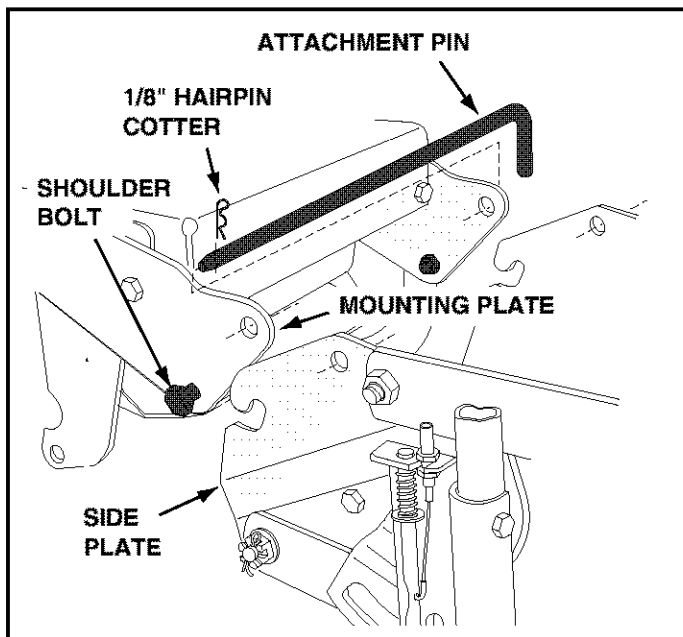

FIGURE 29

RIGHT SIDE VIEW

INSTALLING THE AUGER BELT

- The auger belt comes preassembled to the pulleys on the snow thrower housing. Make sure the belt passes over the top of the auger pulley and then twists 1/4 turn to pass underneath each side idler pulley. The "V" side of the belt must mate with the grooves of the pulleys. See figure 30.

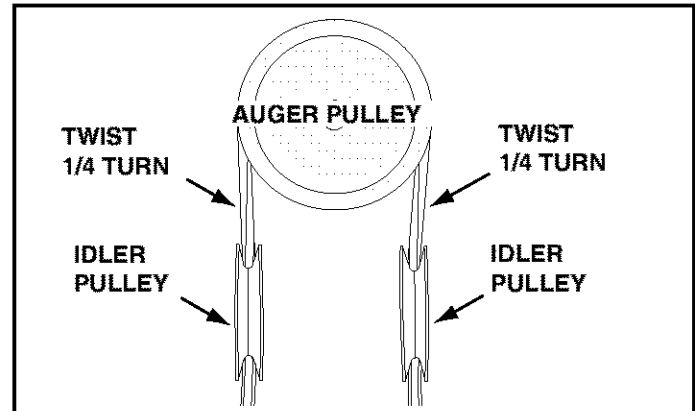

FIGURE 30

- Push the lift handle down to increase slack in the belt (attachment pin must first be removed).
- Remove the 1/8" hairpin cotter that secures the end of the idler arm spring to the right side of the clutch idler assembly. Swing the idler arm to the left side. See figure 31.
- Place the auger belt around the rear pulley and between the two pulleys on the idler arm. The "V" side of the belt must be seated in the grooves of the "V" pulleys. See figure 31.

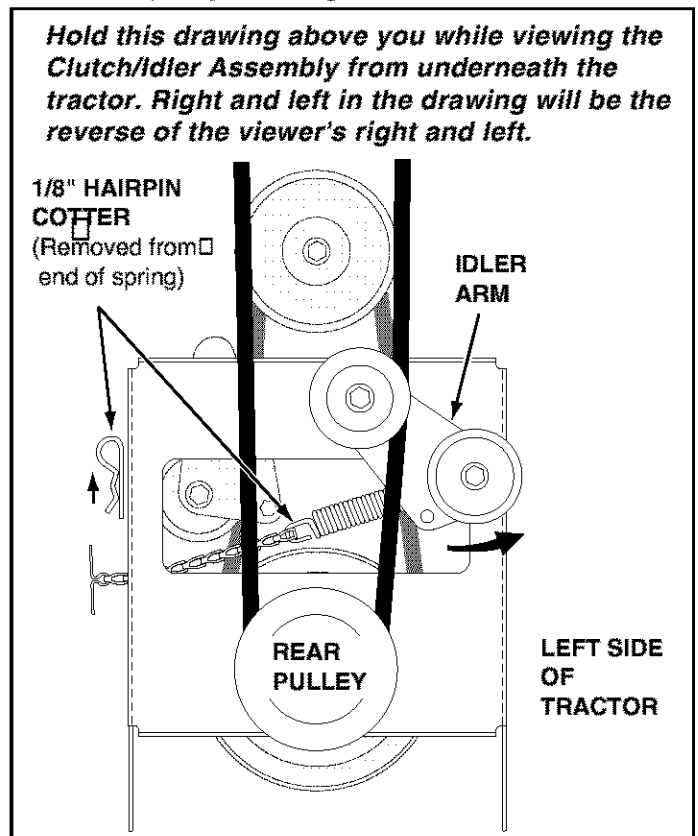

FIGURE 31

VIEWED FROM UNDERNEATH

INSTALLING THE ATTACHMENT PIN

- Lift the front of the snow blower to align the holes in the mounting plates and the side plates. From the left side of the tractor install the attachment pin through the holes, securing it with the 1/8" hairpin cotter. Refer back to figure 29 on page 15.

SETTING THE AUGER BELT TENSION

- Pull the tensioning chain until the end of the spring is pulled through the hole in the side of the Clutch/Idler assembly. Install the 1/8" hairpin cotter through the end of the spring, securing it on the outside of the Clutch/Idler assembly. See figure 32.

IMPORTANT: For correct belt tension, the 1/8" hairpin cotter **must attach** to the end of the spring, **not** to the chain.

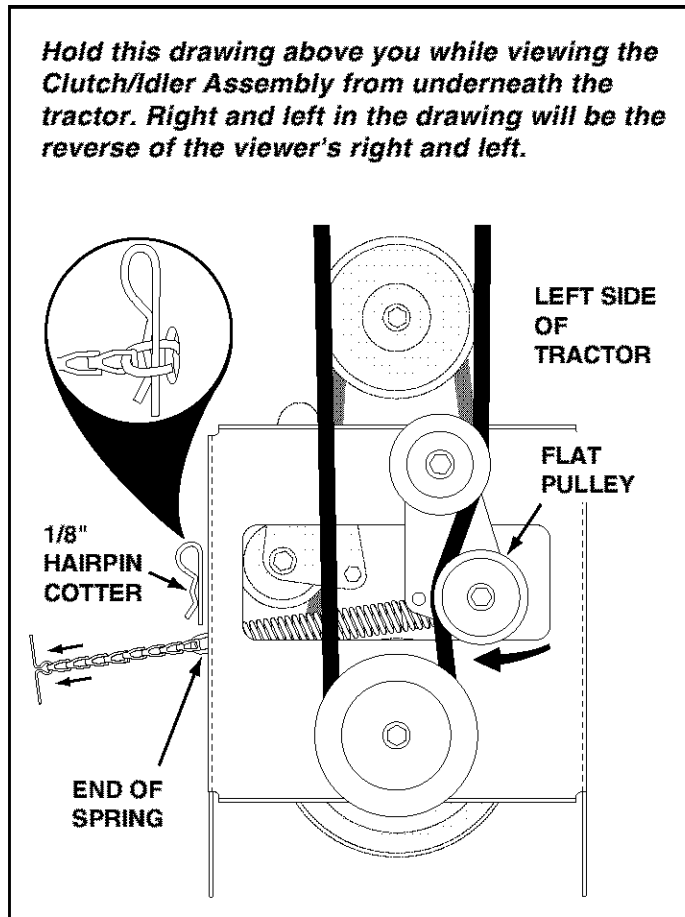

FIGURE 32 VIEWED FROM UNDERNEATH

ATTACHING WEIGHT TRAY TO TRACTOR

- Loosen the top hex bolt on each side of the tractor frame at the rear. Assemble the slotted end of the side braces down onto the loosened bolts. **Do not tighten yet.** See figure 33.
- Place the weight tray on top of the tractor hitch and fasten the side braces to it using two 5/16" x 1" carriage bolts, 5/16" lock washers and 5/16" hex nuts. **Do not tighten yet.** See figure 33.
- Fasten the weight tray to the tractor hitch using a 1/2" x 1-1/4" hex bolt, a 1/2" lock washer and a 1/2" hex nut. **Do not tighten yet.** See figure 33.
- Fasten the cross brace to the side braces using two 5/16" x 1" carriage bolts, 5/16" lock washers and 5/16" hex nuts. See figure 33. **Tighten all loose bolts at this time.**

NOTE: Tire chains on extra wide tires may rub the hex bolt. See the alternate instructions on page 17.

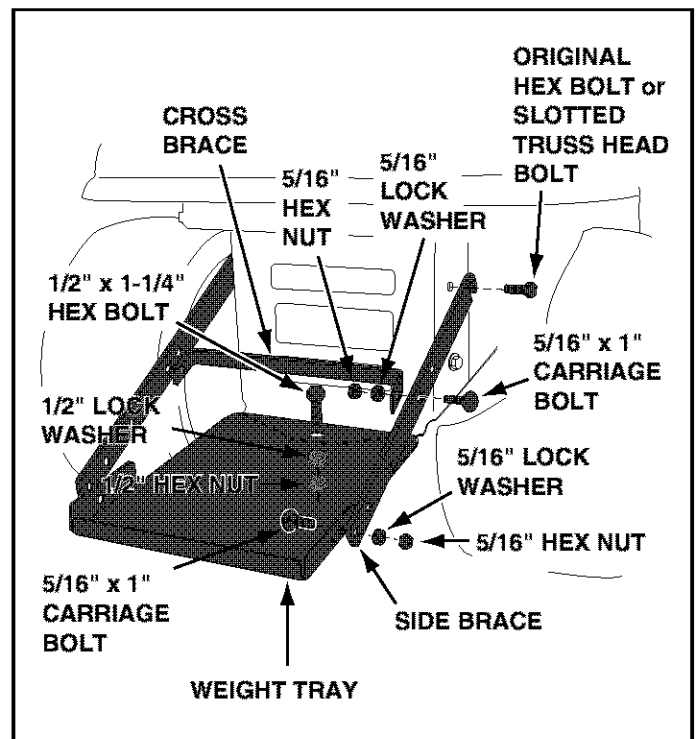

FIGURE 33

- Place the plastic keg on the weight tray and fill with approximately 75 lbs. of dry sand.
- Secure the keg with the rubber tarp strap hooked into the holes in the cross brace. See figure 34.

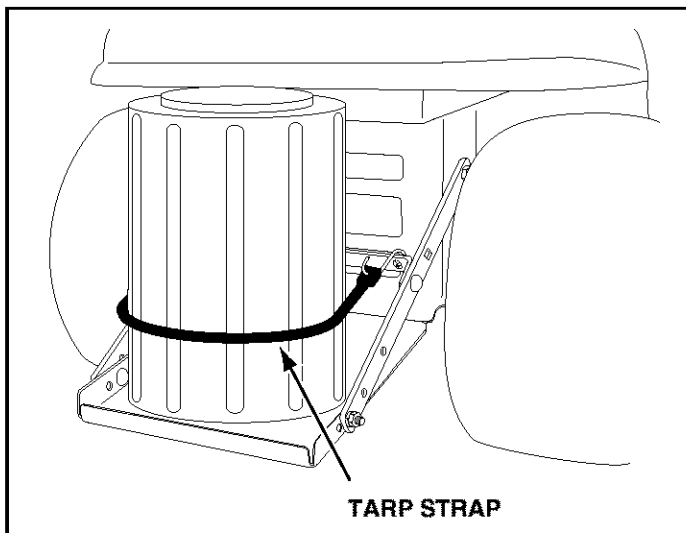

FIGURE 34

ALTERNATE INSTRUCTIONS IF TIRE CHAINS RUB AGAINST HEX BOLT

- Block up the rear of the tractor to allow removal of rear wheels.
- Remove the rear wheels from the axle, retaining the square key and all other parts for reassembly.
- Remove the hex bolt from the top hole in the side of the tractor frame as shown in figure 35.
- Assemble the notched end of each side brace to the top hole in the each side of the tractor frame, using the provided 3/8-16 x 1" slotted truss head bolts. See figure 35.
- Reassemble the wheels onto the axle, making sure to reassemble the square keys and all other parts which were removed.
- Assemble the weight tray to the side braces as instructed in figure 33 on page 16.

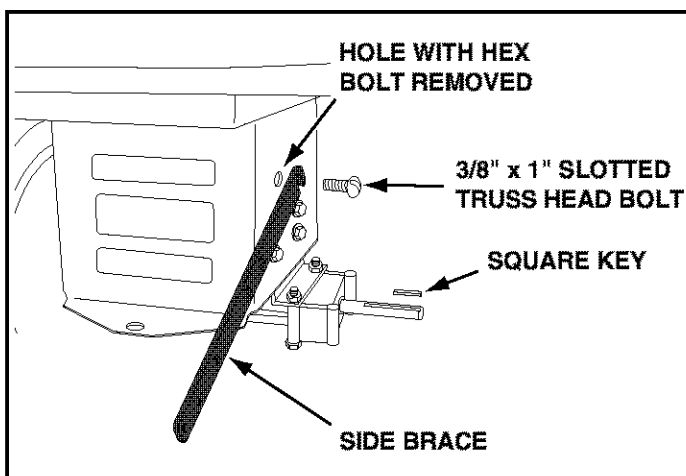

FIGURE 35

- If your tractor is not equipped with rear reflectors, assemble the supplied rear reflectors to the rear fender. Place the reflectors as close to the bottom of the fender and as far apart as the shape of the fender will allow. See figure 36.

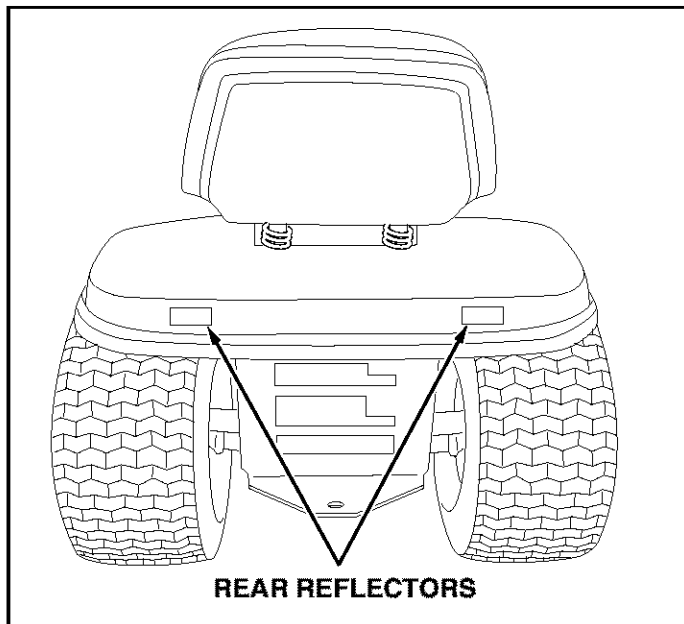

FIGURE 36

CHECKLIST

Before you operate your snow thrower, please review the following checklist to help ensure that you will obtain the best performance from your snow thrower.

- All assembly instructions have been completed with all bolts and nuts properly tightened.
- Check the engine belt and the auger belt. Make sure they are routed properly around pulleys and inside all belt keepers.
- Check discharge chute for proper rotation.
- Check operation of tilt control for upper chute.
- Verify that the lift handle will lock into and release from the raised transport position. (Refer to the Service and Adjustments section.)
- Check skid shoe adjustment. (Refer to the Service and Adjustments section.)

The following additional items are available from Sears to help enhance the performance of your snow thrower. See page 2.

- Tire chains which can be installed to improve traction.
- Rear wheel weights which can be installed in addition to the rear weight tray to improve traction.
- Drift cutter bars which can be installed to help slice off the edges of tall drifts.

OPERATION

KNOW YOUR SNOW THROWER

Read this owner's manual and safety rules before operating your snow thrower.

Compare the illustration below with your snow thrower to familiarize yourself with the various controls and their locations.

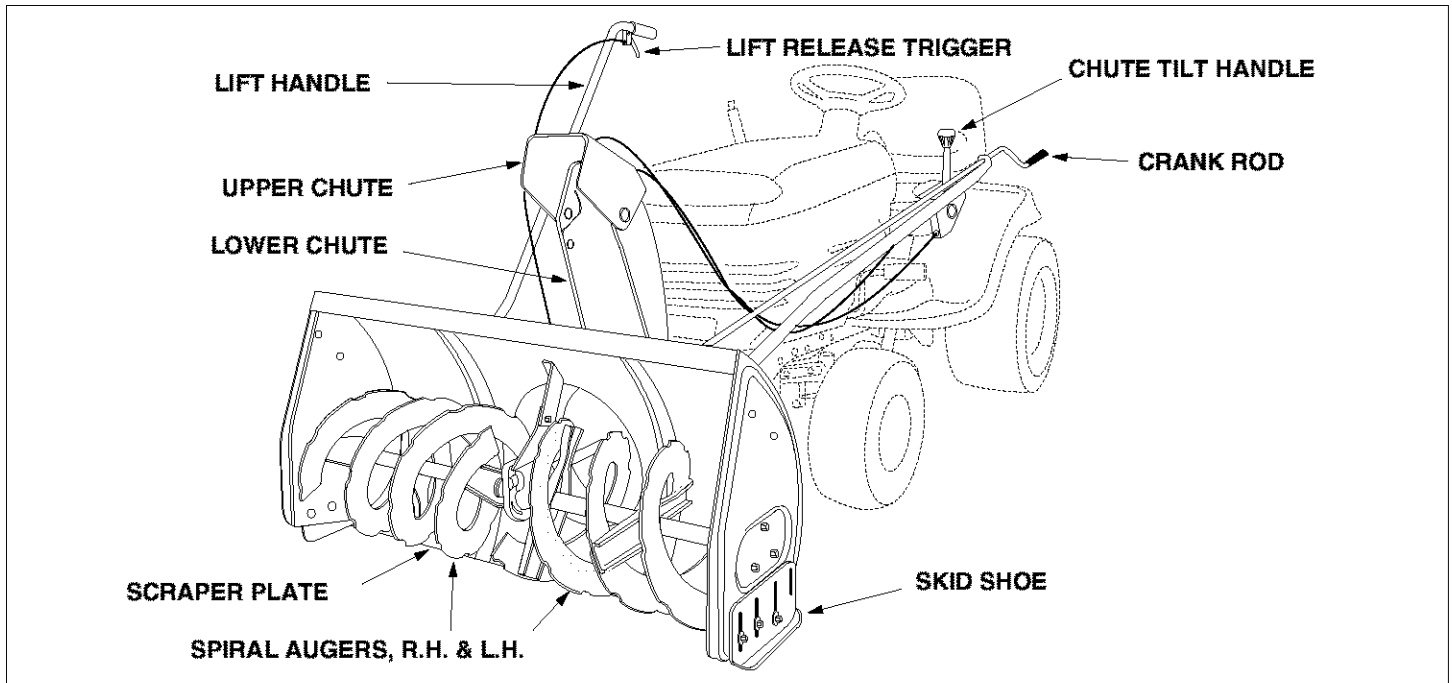

- CHUTE TILT HANDLE** Pivots the Upper Chute up or down to control the angle and distance of discharge.
- CRANK ROD** Rotates the Lower and Upper Chutes to control the direction of discharge.
- LIFT HANDLE** Used to lift or lower the snow thrower to transport or operating position.
- LIFT RELEASE TRIGGER** Releases the lock which holds the snow thrower in the transport position

- UPPER AND LOWER DISCHARGE CHUTE** Controls direction and height of snow discharge.
- SCRAPER PLATE** Replaceable plate that absorbs wear and impact from contact with ground.
- SKID SHOE** Controls amount of clearance between the scraper plate and the ground.
- SPIRAL AUGER, R.H. & L.H.** Feed snow to the impeller fan at the center of the housing.

BEFORE STARTING

- Use the end of assembly checklist to verify that all instructions have been properly completed.
- Make sure the skid shoes are adjusted to maintain adequate ground clearance between the snow thrower and the type of surface to be cleared. (Refer to the Service and Adjustments section.)
- Make sure the tractor engine has the correct oil for winter operation (SAE 5W-30). Refer to tractor owner's manual.

HOW TO START YOUR SNOW THROWER

- The tractor should be sitting with the engine running at full throttle. Move the attachment clutch to the engaged position, starting the snow thrower before the tractor clutch is engaged.

HOW TO STOP YOUR SNOW THROWER

- To stop the snow thrower, disengage the tractor's attachment clutch lever for manual clutches or the clutch switch for electric clutches. Refer to your tractor owner's manual.

HOW TO USE YOUR SNOW THROWER



CAUTION: Never direct discharge towards bystanders or windows. Do not allow anyone in front of unit.

CONTROLLING SNOW DISCHARGE

- To control the direction snow is thrown, the discharge chute has 180 degrees of rotation. Turn the crank rod clockwise to rotate the chute to the right. Turn the crank rod counterclockwise to rotate the chute to the left.
- To control the distance snow is thrown, the upper section of the discharge chute pivots up and down. Push forward on the chute tilt handle to pivot the chute down, decreasing the distance snow is thrown. Pull back on the handle to pivot the chute up, increasing the distance snow is thrown.

RAISING AND LOWERING

- To raise, push down on the lift handle until the snow thrower locks in the raised transport position.
- To lower, push down slightly on the lift handle and pull the trigger. With the trigger pulled, slowly lower the snow thrower until it reaches the ground.



CAUTION: Do not operate the snow thrower without the rear weight attached to the tractor to provide extra traction and stability.

REMOVING SNOW

Snow removal conditions vary greatly from light fluffy snowfall to wet heavy snow. Operating instructions must be flexible to fit the conditions encountered. The operator must adapt the lawn tractor and snow thrower to depth of snow, wind direction, temperature and surface conditions.

- Before beginning operation, thoroughly inspect the area of operation and remove all door mats, sleds, boards, wires and other foreign objects.
- The spiral auger speed is directly related to engine speed. For maximum snow removal and discharge, maintain high engine r.p.m. (full throttle). It is advisable to operate the lawn tractor at a slow ground speed (1st gear) for safe and efficient snow removal.
- In deep, drifted or banked snow it will be necessary to use full throttle and a slow ground speed (1st gear). Drive forward into the snow, depress the tractor's clutch-brake pedal and allow the spiral auger to clear the snow. Repeat this method until a path is cleared. On the second pass, overlap the first enough to allow the snow thrower to handle the snow without repeated stopping and starting of forward motion.

- In extremely deep snow, raise the snow thrower from the ground to remove the top layer and drive forward only until the tractor's front tires reach the uncleared bottom layer of snow. Depress the tractor's clutch-brake pedal and allow the spiral auger to clear the snow. Reverse the tractor and lower the snow thrower to the ground. Drive the tractor forward until the snow again becomes too deep. Repeating this process into and out of drifts will eventually clear even the deepest of snow piles.
- If the snow thrower becomes clogged with snow or jammed with a foreign object, disengage the snow thrower immediately and shut off the tractor engine. Unclog the snow thrower before resuming operation.



DANGER: Shut off engine and disengage snow thrower before unclogging discharge chute. Unclog using a wooden stick, not your hands.

OPERATING TIPS

- Discharge snow down wind whenever possible.
- To help prevent snow from sticking to the snow thrower, allow the snow thrower to reach outdoor temperature before using it. A light coat of wax may also be applied to the inside surface of the snow thrower housing and discharge chute.
- Use tire chains to improve traction.
- Use rear wheel weights to improve traction.
- Before the first snowfall, remove all stones, sticks and other objects which could become hidden by the snow. Permanent obstacles should be marked for visibility.
- Overlap each pass slightly to assure complete snow removal.

MAINTENANCE

CUSTOMER RESPONSIBILITIES

- Read and follow the maintenance schedule and the maintenance procedures listed in this section.

MAINTENANCE SCHEDULE Fill in dates as you complete regular service.	Service Dates											
	Before each use	After each use	Every season	Before storage								
Check for loose fasteners	X											
Check scraper and shoes for wear	X		X									
Cleaning			X									
Lubrication Section		X										

LUBRICATION

- Oil all pivot points on the snow thrower.
- Oil the pivot points of the two idler arms on the clutch/idler assembly.
- Apply penetrating oil to the control cables of the discharge chute.
- Apply a good grade of spray lubricant to the trigger assembly and the chute tilt control assembly.

CHECK SCRAPER AND SHOES FOR WEAR (Refer to figures 37 and 38 on page 20.)

- The scraper plate and skid shoes on the bottom of the snow thrower are subject to wear. To prevent damage to the spiral auger housing, replace plate and shoes before wear is excessive.

SERVICE AND ADJUSTMENTS



CAUTION: Before servicing or adjusting the snow thrower, shut off the engine, remove the spark plug wire(s), set the parking brake and remove the key from the tractor ignition.

REPLACING AUGER BELT

- Disengage the tractor's attachment clutch.
- Lower the snow thrower to the ground.
- Remove the attachment pin.
- Lock the snow thrower's lift handle in the down position to decrease belt tension.
- Release the spring tension from the auger belt idler arm on the bottom of the clutch/idler assembly.
- Remove the auger drive belt from the clutch/idler assembly and from the spiral auger housing.
- Install new belt over top of large auger drive pulley and under the two side idler pulleys. Twist the belt 1/4 turn to seat the "V" of the belt in the groove of each idler pulley. Refer to figure 30 on page 15. Assemble the belt onto the clutch/idler assembly. Refer to figures 31 and 32 on pages 15 and 16.

SKID SHOE ADJUSTMENT

- The skid shoes are mounted on each side of the spiral auger housing. They regulate the distance the scraper plate is raised above the plowing surface. When removing snow from a gravel driveway or an uneven surface, it is advisable to keep the scraper plate as high above the surface as possible to prevent possible damage to the spiral auger. On blacktop or concrete surface, keep the scraper plate as close to the surface as possible.
- Raise the snow thrower off the ground and place a block under each end of the scraper plate. Loosen the six hex nuts securing the skid shoes to the housing. Adjust the skid shoes up or down and retighten the nuts securely. Adjust both skid shoes to the same height to keep the housing and the scraper plate level. See figure 37.

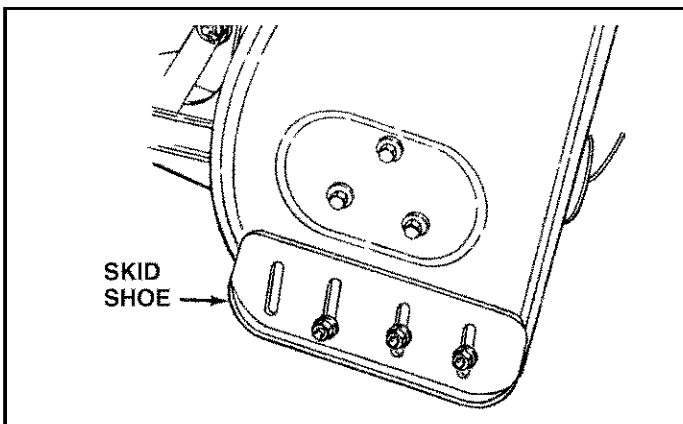

FIGURE 37

LIFT RELEASE CABLE ADJUSTMENT

- If the lift rod does not lock the snow thrower securely in the transport position, loosen the upper hex nut on the lift bracket a few turns and tighten the lower hex nut. Refer to figure 24 on page 13.
- If the lift rod fails to unlock completely to lower the snow thrower, loosen the lower hex nut on the lift bracket a few turns and tighten the upper hex nut. Refer to figure 24 on page 13.

CLUTCH DISENGAGEMENT ADJUSTMENT (Only tractors with clutch engagement rods.)

If the spiral auger on the snow thrower does not stop when the attachment clutch lever on the tractor is disengaged, then adjustment is necessary. Proceed as follows. Refer back to figure 13 on page 9.

- Place the attachment clutch lever in the disengaged position.
- Remove the hairpin cotter from the engagement rod trunnion and lift the trunnion out of the hole in the idler arm.
- Screw the trunnion a few turns towards the front end of the rod.
- Replace the trunnion into the hole in the idler arm and secure it with the hairpin cotter. Check the operation of the snow thrower. If the spiral augers still do not stop, repeat the above steps until the augers stop when the attachment clutch lever is placed in the disengaged position.

SPIRAL AUGERS

- The spiral augers are secured to the auger shaft with two shear bolts and hex lock nuts. If you hit a foreign object or if ice jams the augers, the snow thrower is designed so that the bolts will shear.
- If the augers will not turn, check to see if the shear bolts have sheared. See figure 38. Two replacement shear bolts and hex lock nuts have been provided with the snow thrower. For future use order part number 710-0890A shear bolt and number 43064 hex lock nut.

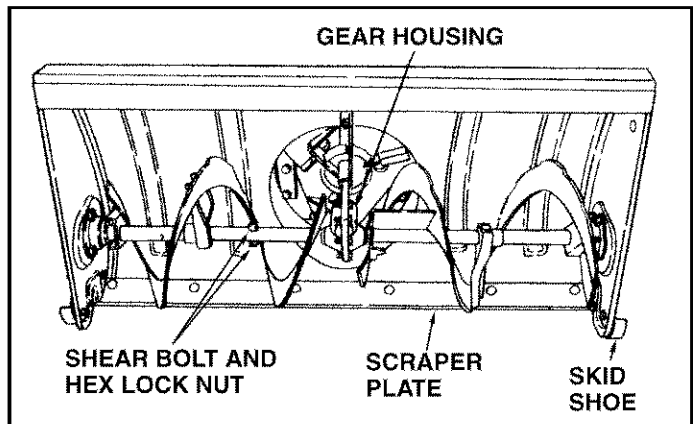

FIGURE 38

STORAGE

STORAGE RECOMMENDATIONS

- Lower the snow thrower to the ground.
- Remove the snow thrower from the tractor.
- Clean the snow thrower thoroughly. Wash off any salt deposit which may have dried on the thrower and housing.
- Any bare metal that has become exposed should be painted or coated with a light oil to prevent rust.
- Store in a dry place.

REMOVING THE SPIRAL AUGER HOUSING

- Lower the snow thrower to the ground.
- Remove the attachment pin. See figure 29 on page 15.
- Lock the snow thrower's lift handle in the down position to decrease belt tension.
- Release the spring tension from the auger belt idler arm on the bottom of the clutch/idler assembly.
- Remove the auger drive belt from the clutch/idler assembly. See figure 31 on page 15.
- Pull the spiral auger housing assembly off of the tractor.

ADDITIONAL PARTS TO REMOVE AT END OF SEASON

- Remove the clutch/idler assembly. (The two hanger brackets and the two shoulder bolts may be left attached to the tractor frame.)
- Remove the drive belt from the engine pulley.
- Remove the engine pulley keeper and replace it with the tractor's original engine pulley keeper (rod or cable operated attachment clutches only).
- Remove the engagement rod from the tractor's clutch arm (rod operated attachment clutches only). See figure 11 on page 9.
- If a rear mounted attachment is to be used, remove the rear weight tray by removing the bolt from the tractor hitch and loosening the two bolts fastening the tray's side braces to the tractor. Be sure to retighten the two bolts in the side of the tractor. See figure 33 on page 16.
- If a front mounted attachment is to be used, remove the side plates from the tractor. Be sure to assemble bolts back into the empty holes in the tractor frame. See figures 1 and 2 on page 6.

TROUBLESHOOTING

PROBLEM	CAUSE	CORRECTION
Spiral augers don't turn	<ol style="list-style-type: none"> 1. Upper or lower V belt too loose 2. Upper or lower V belt broken 3. Shear bolts are sheared. 	<ol style="list-style-type: none"> 1. Increase tension on V belt 2. Replace V belt 3. Replace shear bolts
Clogged discharge chute	<ol style="list-style-type: none"> 1. Tractor ground speed too fast 2. Tractor throttle set too low 3. Snow too deep 4. Snow melts during contact with the snow thrower 	<ol style="list-style-type: none"> 1. Use lower tractor gear 2. Increase to full throttle 3. Raise the snow thrower 4. Allow snow thrower to cool to outdoor temperature before using
Snow thrower stalls tractor engine	<ol style="list-style-type: none"> 1. Object jammed in spiral auger 2. Hard or heavy snow 	<ol style="list-style-type: none"> 1. Stop engine, disengage the snow thrower clutch and clear the auger 2. Increase to full throttle and decrease ground speed
Front wheels slide instead of steering	Not enough traction at front wheels	<ol style="list-style-type: none"> 1. Increase scraper plate clearance by lowering skid shoes 2. Pull down on lift handle to increase weight on front wheels
Snow thrower rides up over snow	<ol style="list-style-type: none"> 1. Tractor ground speed too fast 2. Bottom snow is icy or hard packed 	<ol style="list-style-type: none"> 1. Reduce ground speed 2. Lower the skid shoes so that front of skid shoe is lower than the rear

PARTS

REPAIR PARTS FOR MODEL 486.248392 42" SNOW THROWER

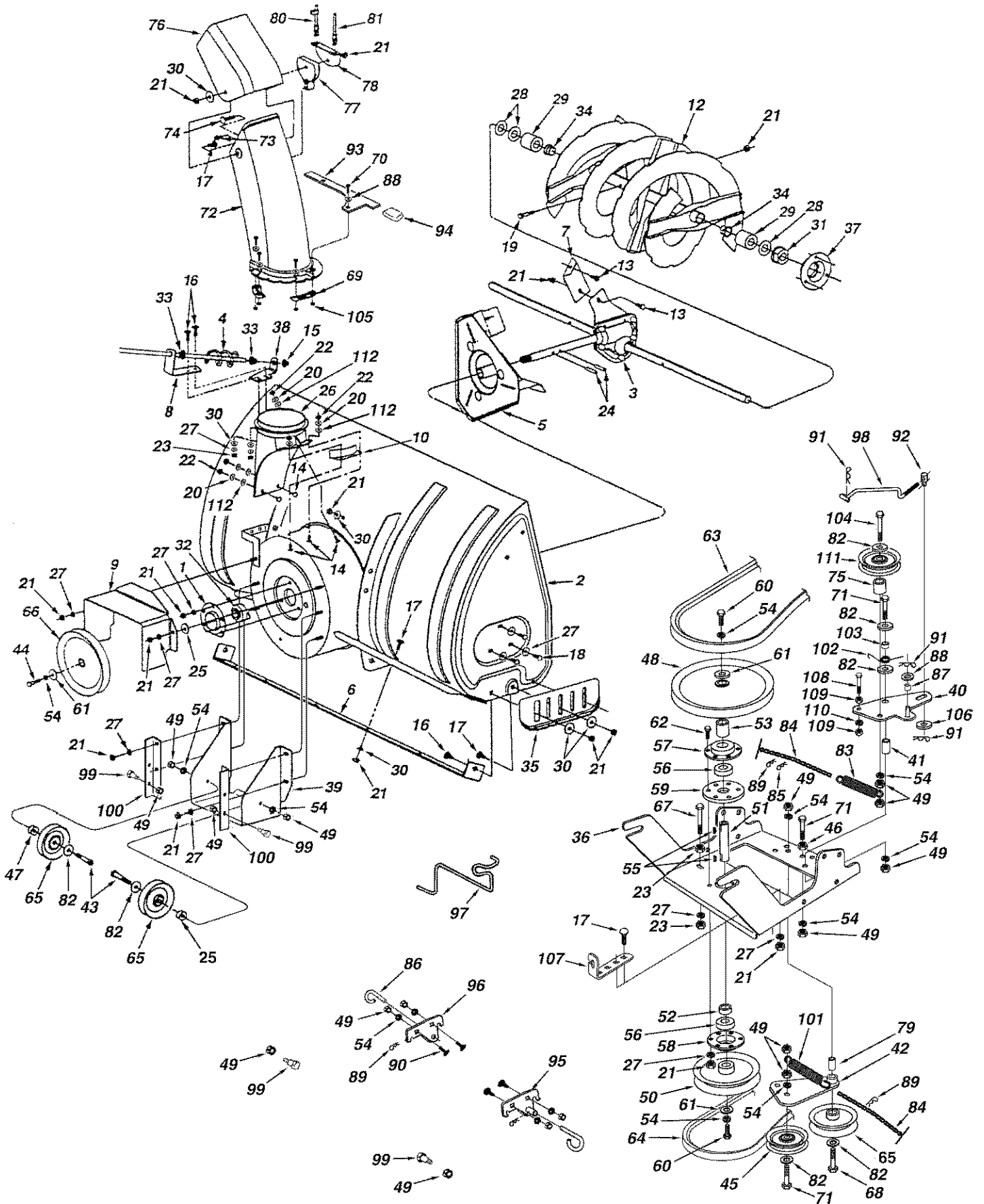

REPAIR PARTS FOR MODEL 486.248392 42" SNOW THROWER

REF. NO.	PART NO.	QTY.	DESCRIPTION	REF. NO.	PART NO.	QTY.	DESCRIPTION
1	05931	1	Housing, Bearing	57	08253B	1	Housing, Bearing
2	64184	1	Housing Assembly	58	15296A	1	Housing, Open Bearing
3	618-0616	1	Gear Assembly	59	14088B	1	Spacer, Spindle
4	63579	1	Chute Crank Rod Assembly	60	44377	2	Hex Bolt, 3/8-24 x 1"
5	63768	1	Impeller Assembly	61	736-0247	3	Washer,
6	24773	1	Scraper Plate	62	43063	3	Hex Bolt, 5/16-18 x 1"
7	703-2734	1	Bracket, Housing Brace	63	46989	1	Belt, V Type Drive
8	703-2735A	1	Bracket, Chute Crank	64	47846	1	Belt, V Type Auger
9	24816	1	Cover, Belt	65	47044	3	Pulley, V Type 4"
10	705-5226	1	Chute Reinforcement	66	47026	1	Pulley, V Type
11	705-5269	1	Spiral Assembly, L.H. (not shown)	67	47025	1	Hex Bolt, 5/16-18 x 3-1/2"
12	705-5270	1	Spiral Assembly, R.H.	68	43432	1	Hex Bolt, 3/8-16 x 2-1/2"
13	43182	2	Hex Bolt, 5/16-18 x 3/4" Lg.	69	731-0851A	3	Chute Keeper
14	44950	5	Carriage Bolt, 1/4-20 x 3/4"	70	43661	6	Hex Bolt, 1/4-20 x 1"
15	44917	1	Palnut, 3/8"	71	43054	3	Hex Bolt, 3/8-16 x 2"
16	44326	4	Carriage Bolt, 5/16-18 x 1" Lg.	72	731-1300A	1	Chute, Lower
17	43080	12	Carriage Bolt, 5/16-18 x 3/4" Lg.	73	710-0896	1	Screw, 1/4-14 x 5/8"
18	46703	6	Bolt, Self-Tap 5/16" x 3/4"	74	43681	1	Carriage Bolt, 5/16-18 x 1-1/2"
19	710-0890A	2	Bolt, Shear 5/16-18 x 1-1/2"	75	24571	1	Spacer
20	43088	5	Washer, 1/4"	76	731-1320	1	Chute, Upper
21	43064	34	Hex Lock Nut, 5/16-18 Thd.	77	731-1313C	1	Guide, Cable
22	43013	5	Hex Lock Nut, 1/4-20	78	784-5594	1	Bracket, Cable
23	43083	4	Hex Nut, 5/16-18	79	24472	1	Spacer, Pivot
24	715-0114	2	Spiral Pin, 1/4" x 1-1/2" Lg.	80	746-0929	1	Cable, Chute Control With Clip
25	750-0437	2	Bushing	81	746-0928	1	Cable, Chute Control
26	731-1379A	1	Chute Adapter	82	43070	7	Washer, 3/8"
27	43086	21	Lock Washer, 5/16"	83	46959	1	Spring
28	736-0188	6	Washer, .76" x 1.49" x .06"	84	46963	2	Chain
29	711-0469	4	Spacer, .75 ID x 1.25 OD x .5 L	85	43055	1	Pin, Hair Cotter, 3/32"
30	43081	16	Washer, 5/16" Std. Wrt.	86	43038	2	Pin, Pivot Lock
31	47615	2	Bearing, Flange	87	23727	1	Spacer
32	741-0309	1	Bearing, Ball	88	43088	7	Washer, 1/4"
33	741-0475	2	Bushing, Plastic 3/8"	89	43343	4	Pin, Hair Cotter #4 (1/8")
34	741-0493A	4	Bearing, Split, 3/4"	90	43350	4	Carriage Bolt, 3/8-16 x 1"
35	24279	2	Skid Shoe	91	47134	3	Pin, Hair Cotter 5/64"
36	24294	1	Frame Clutch and Pulley	92	711-0198	1	Trunnion
37	784-5618	2	Housing, Bearing	93	24394	1	Bracket, Chute Anti-rotation
38	24393	1	Bracket, Chute Crank	94	1643-60	1	Plastic Cap
39	24281	1	Bracket, Idler	95	64452	1	Hanger Bracket Assembly, R.H.
40	63904	1	Idler Arm Assembly	96	64451	1	Hanger Bracket Assembly, L.H.
41	24286	1	Spacer, Pivot	97	47043	1	Keeper, Engine Pulley
42	63762	1	Idler Bracket Assembly	98	46948	1	Rod, Engagement
43	41576	2	Hex Bolt, 3/8-16 x 1-3/4"	99	48106	4	Bolt, Shoulder
44	44377	1	Hex Bolt, 3/8-24 x 1"	100	24466	2	Bracket, Down Stop
45	756-0405	1	Pulley, Flat 3-3/4"	101	47620	1	Spring
46	43015	1	Hex Nut, 3/8-16	102	47607	1	Spring, Torsion
47	711-0242	1	Spacer	103	23625	1	Spacer
48	46981	1	Pulley, V Type 9"	104	43509	1	Hex Bolt, 3/8-16 x 2-3/4" Lg.
49	43082	17	Nut, Hex Lock, 3/8-16	105	47598	6	Hex Lock Nut, 1/4" Wash. Face
50	46982	1	Pulley, V Type 5-1/2"	106	47605	1	Washer, Flat 3/8"
51	738-0680	1	Shaft	107	24558	1	Cable Bracket
52	750-0456	1	Spacer	108	43796	1	Hex Bolt, 1/4-20 x 2-3/4"
53	750-0660	1	Spacer	109	43178	2	Hex Nut, 1/4-20
54	43003	14	Lock Washer, 3/8"	110	43177	1	Lock Washer, 1/4"
55	714-0161	2	Key	111	48883	1	Pulley, Flat 3-5/8"
56	741-0919	2	Bearing, Ball	112	48015	5	Washer, Nylon
					48936	1	Owner's Manual

REPAIR PARTS FOR MODEL 486.248392 42" SNOW THROWER

REF. NO.	PART NO.	QTY.	DESCRIPTION	REF. NO.	PART NO.	QTY.	DESCRIPTION
1	63764	1	Lift Shaft Assembly	41	703-2735A	1	Bracket, Chute Crank
2	710-0865	2	Hex Bolt, 1/2-13 x 1"	42	720-0201A	1	Knob, Crank
3	710-0367	2	Hex Bolt, 5/8-11 x 1-1/2"	43	44917	1	Palnut, 3/8"
4	711-0332	2	Pin, Bracket Lift	45	63579	1	Assembly, Chute Crank Rod
5	712-0261	2	Nut, Hex Lock 5/8-11 Thread	46	784-5604	1	Handle, Chute Tilt
6	43262	6	Nut, Hex Lock 1/2-13	47	720-0232	1	Knob
8	142	4	Pin, Cotter 1/8" x 3/4"	48	603-0302	1	Assembly, Chute Tilt Bracket
9	43093	1	Pin, Cotter 1/8" x 1-1/2"	49	731-1313C	1	Guide, Cable
10	R19171616	6	Washer, 17/32" x 1"	50	746-0928	1	Cable, Chute Control
12	741-0192	2	Bearing, Flange With Flats	51	746-0929	1	Cable, Chute Control with Clip
13	783-0380	2	Link, 15.80" Long	52	43064	5	Nut, Hex Lock 5/16-18
14	783-0381	2	Link, 11.75" Long	53	43081	2	Washer, 5/16"
15	24476	2	Link, 4.88" Long	54	24285	1	Plate, Mounting (L.H.)
16	24311	1	Rod, Spacer	55	24284	1	Plate, Mounting (R.H.)
17	47599	2	Hex Bolt, 5/16-18 x 1" (Locking)	56	47093	1	Keg, Plastic
18	43086	16	Lock Washer, 5/16"	57	23812	2	Brace, Side (Weight Tray)
19	24298	1	Bracket, Lift	58	24288	1	Brace, Cross (Weight Tray)
20	683-0130	1	Assembly, Handle Lift Bracket	59	24289	1	Tray, Weight
21	747-3248A	1	Rod, Index Lift	60	47631	4	Hex Bolt, 3/8-16 x 1" Self Tap
22	47277	1	Screw, Hex Slotted #10	61	43003	6	Lock Washer, 3/8"
23	732-0306	1	Spring, Compression	62	43082	4	Nut, Hex Lock 3/8-16
24	R19131316	1	Washer, 13/32" x 13/16"	63	43083	10	Nut, Hex 5/16-18
25	736-0400	1	Washer, .218" x .62"	64	43084	2	Hex Bolt, 5/16-18 x 1-3/4"
26	43080	1	Carriage Bolt, 5/16-18 x 3/4"	65	44326	4	Carriage Bolt, 5/16-18 x 1"
27	43182	2	Hex Bolt, 5/16-18 x 3/4"	66	43351	1	Hex Bolt, 1/2-13 x 1-1/4"
28	R19111116	2	Washer, 11/32 x 11/16 x 3/64	67	43353	1	Lock Washer, 1/2"
29	47338	1	Pin, Spring 1/4" x 1-1/2"	68	43682	2	Carriage Bolt, 5/16-18 x 1-1/4"
30	46954	1	Pin, Attachment	69	43790	1	Strap, Tarp 25" Long
31	43343	1	Pin, Haircotter #4 (1/8")	70	44215	2	Carriage Bolt, 5/16-18 x 1-3/4"
32	24654	1	Plate, Side (R.H.)	71	44695	2	Washer, Bowed
33	24653	1	Plate, Side (L.H.)	72	712-0206	1	Nut, Hex 1/2-13
34	47326	1	Tube, Lift Handle	73	48106	2	Bolt, Shoulder
35	47555	1	Cable, Lift	74	726-0178	3	Tie, Nylon
36	712-0127	1	Nut, Flat Weld #10-24	75	63755	1	Assembly, Cable Release Trigger
37	710-1233	1	Screw, Oval #10-24 x 1"	76	47317	1	Plastic Cap
38	46446	1	Grip, Handle	77	43601	1	Washer, 1.59" x 1.032" x .060"
39	47027	1	Tube, Crank Rod Support	78	47336	1	Pin, Spring 5/32" x 1-1/2"
40	741-0475	2	Bushing, 3/8" Plastic	79	47361	2	Slotted Truss Hd. Bolt, 3/8-16 x 1"
				80	47554	1	Housing, Trigger
				81	R19172410	2	Washer, 1/2"
				82	46584	1	Nut, Whizlock, 5/16-18
				83	47788	2	Reflector, Rear

NOTES

SLOPE GUIDE

(Keep this sheet in a safe place for future reference.)

Use this guide to determine if a slope is safe for the operation of your tractor and snow thrower. Refer also to the instructions in your vehicle owners manual.

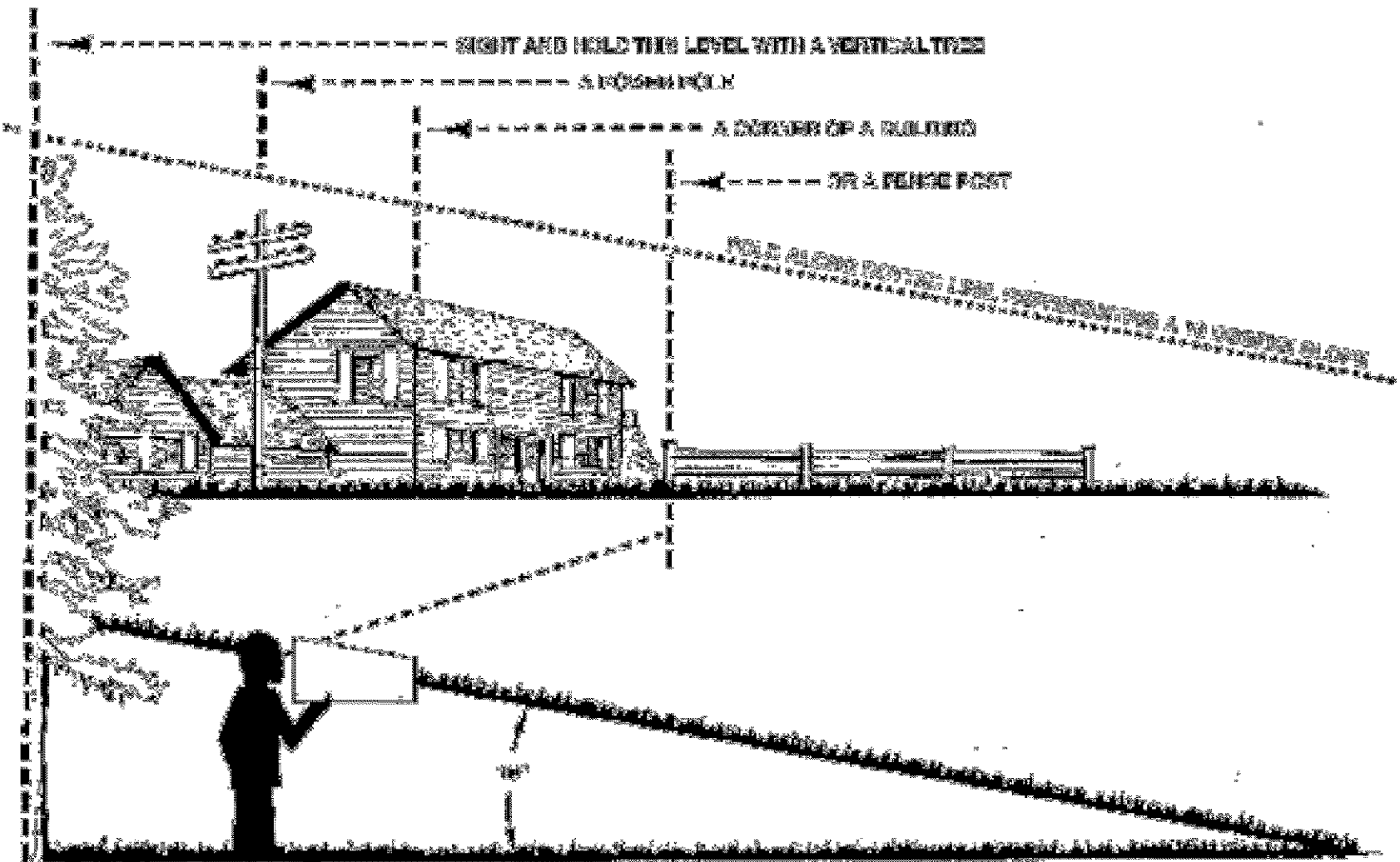

CAUTION: DO NOT OPERATE YOUR TRACTOR AND SNOW THROWER ON A SLOPE IN EXCESS OF 10 DEGREES. BE SURE OF YOUR TRACTOR'S TOWING AND BRAKING CAPABILITIES BEFORE OPERATING ON A SLOPE. AVOID ANY SUDDEN TURNS OR MANEUVERS WHILE ON A SLOPE.

Get it fixed, at your home or ours!

For repair of major brand appliances **in your own home...**
no matter who made it, no matter who sold it!

1-800-4-MY-HOMESM Anytime, day or night
(1-800-469-4663)

www.sears.com

To bring in products such as vacuums, lawn equipment and electronics
for repair, call for the location of your nearest **Sears Parts & Repair Center.**

1-800-488-1222 Anytime, day or night

www.sears.com

For the replacement parts, accessories and owner's manuals
that you need to do-it-yourself, call **Sears PartsDirectSM!**

1-800-366-PART 6 a.m. – 11 p.m. CST,
(1-800-366-7278) 7 days a week

www.sears.com/partsdirect

To purchase or inquire about a Sears Service Agreement:

1-800-827-6655

7 a.m. – 5 p.m. CST, Mon. – Sat.

Para pedir servicio de reparación a domicilio,
y para ordenar piezas con entrega a domicilio:

1-888-SU-HOGARSM
(1-888-784-6427)

Au Canada pour service en français:

1-877-LE-FOYERSM
(1-877-533-6937)

