

KitchenAid®

BUILT-IN MICROWAVE OVEN

Use & Care Guide

For questions about features, operation/performance, parts, accessories or service, call: 1-800-422-1230,
or visit our website at... www.kitchenaid.com

Table of Contents..... 2



Model KBMS1454R
8205301/4619-694-50831



TABLE OF CONTENTS

MICROWAVE OVEN SAFETY	3
Electrical Requirements	5
PARTS AND FEATURES	6
Turntable	6
MICROWAVE OVEN CONTROL	6
Display	7
Start	7
Add a Minute	7
Cancel/Off	7
Dial.....	7
Select.....	7
Clock	7
Tones.....	7
Demo Mode.....	7
Control Lock.....	8
Cooling Fan	8
MICROWAVE OVEN USE	8
Food Characteristics	8
Cooking Guidelines	8
Cookware and Dinnerware	9
Aluminum Foil and Metal	9
Cooking Power.....	9
Cook Time Set.....	10
Doneness	10
Meal Prep Cook	10
Meal Prep Reheat.....	11
Meal Prep Defrost	11
One Touch Sensor Cooking.....	12
Keep Warm.....	12
MICROWAVE OVEN CARE	13
General Cleaning.....	13
TROUBLESHOOTING	14
ASSISTANCE OR SERVICE	15
Replacement Parts.....	15
WARRANTY	16



MICROWAVE OVEN SAFETY

Your safety and the safety of others are very important.

We have provided many important safety messages in this manual and on your appliance. Always read and obey all safety messages.



This is the safety alert symbol.

This symbol alerts you to potential hazards that can kill or hurt you and others.

All safety messages will follow the safety alert symbol and either the word “DANGER” or “WARNING.” These words mean:

⚠ DANGER

You can be killed or seriously injured if you don't immediately follow instructions.

⚠ WARNING

You can be killed or seriously injured if you don't follow instructions.

All safety messages will tell you what the potential hazard is, tell you how to reduce the chance of injury, and tell you what can happen if the instructions are not followed.

IMPORTANT SAFETY INSTRUCTIONS

When using electrical appliances basic safety precautions should be followed, including the following:

WARNING: To reduce the risk of burns, electric shock, fire, injury to persons, or exposure to excessive microwave energy:

- Read all instructions before using the microwave oven.
- Read and follow the specific “PRECAUTIONS TO AVOID POSSIBLE EXPOSURE TO EXCESSIVE MICROWAVE ENERGY” found in this section.
- The microwave oven must be grounded. Connect only to properly grounded outlet. See “GROUNDING INSTRUCTIONS” found in this section and in the provided Installation Instructions.
- Install or locate the microwave oven only in accordance with the provided Installation Instructions.
- Some products such as whole eggs in the shell and sealed containers – for example, closed glass jars – are able to explode and should not be heated in the microwave oven.
- Use the microwave oven only for its intended use as described in this manual. Do not use corrosive chemicals or vapors in the microwave oven. This type of oven is specifically designed to heat, cook, or dry food. It is not designed for industrial or laboratory use.
- As with any appliance, close supervision is necessary when used by children.
- Do not operate the microwave oven if it has a damaged cord or plug, if it is not working properly, or if it has been damaged or dropped.
- The microwave oven should be serviced only by qualified service personnel. Call an authorized service company for examination, repair, or adjustment.
- See door surface cleaning instructions in the “Microwave Oven Care” section.
- To reduce the risk of fire in the oven cavity:
 - Do not overcook food. Carefully attend the microwave oven when paper, plastic, or other combustible materials are placed inside the oven to facilitate cooking.
 - Remove wire twist-ties from paper or plastic bags before placing bags in oven.
 - If materials inside the oven ignite, keep oven door closed, turn oven off, and disconnect the power cord, or shut off power at the fuse or circuit breaker panel.
 - Do not use the cavity for storage purposes. Do not leave paper products, cooking utensils, or food in the cavity when not in use.

SAVE THESE INSTRUCTIONS

IMPORTANT SAFETY INSTRUCTIONS

- Liquids, such as water, coffee, or tea are able to be overheated beyond the boiling point without appearing to be boiling. Visible bubbling or boiling when the container is removed from the microwave oven is not always present. THIS COULD RESULT IN VERY HOT LIQUIDS SUDDENLY BOILING OVER WHEN THE CONTAINER IS DISTURBED OR A SPOON OR OTHER UTENSIL IS INSERTED INTO THE LIQUID.
To reduce the risk of injury to persons:
 - Do not overheat the liquid.
 - Stir the liquid both before and halfway through heating it.
 - Do not use straight-sided containers with narrow necks.
 - After heating, allow the container to stand in the microwave oven for a short time before removing the container.
 - Use extreme care when inserting a spoon or other utensil into the container.
- Oversized foods or oversized metal utensils should not be inserted in the microwave oven as they may create a fire or risk of electric shock.
- Do not clean with metal scouring pads. Pieces can burn off the pad and touch electrical parts involving a risk of electric shock.
- Do not use paper products when appliance is operated in the “PAN BROWN” mode (on models with this feature).
- Do not store any materials, other than manufacturer’s recommended accessories, in this oven when not in use.
- Do not store anything directly on top of the microwave oven when the microwave oven is in operation.
- Do not deep fry in microwave oven. Microwavable utensils are not suitable, and it is difficult to maintain appropriate deep frying temperatures.
- Do not cover or block any openings on the microwave oven.
- Do not store this microwave oven outdoors. Do not use the microwave oven near water - for example, near a kitchen sink, in a wet basement, or near a swimming pool, or similar locations.
- Do not immerse cord or plug in water.
- Keep cord away from heated surfaces.
- Do not let cord hang over edge of table or counter.
- Do not mount over a sink.
- Do not cover racks or any other part of the oven with metal foil. This will cause overheating of the oven.

SAVE THESE INSTRUCTIONS

PRECAUTIONS TO AVOID POSSIBLE EXPOSURE TO EXCESSIVE MICROWAVE ENERGY

- (a) Do not attempt to operate this oven with the door open since open-door operation can result in harmful exposure to microwave energy. It is important not to defeat or tamper with the safety interlocks.
- (b) Do not place any object between the oven front face and the door or allow soil or cleaner residue to accumulate on sealing surfaces.
- (c) Do not operate the oven if it is damaged. It is particularly important that the oven door close properly and that there is no damage to the:
 - (1) Door (bent),
 - (2) Hinges and latches (broken or loosened),
 - (3) Door seals and sealing surfaces.
- (d) The oven should not be adjusted or repaired by anyone except properly qualified service personnel.

Electrical Requirements

⚠ WARNING



Electrical Shock Hazard

Plug into a grounded 3 prong outlet.

Do not remove ground prong.

Do not use an adapter.

Do not use an extension cord.

Failure to follow these instructions can result in death, fire, or electrical shock.

Observe all governing codes and ordinances. A 120 Volt, 60 Hz, AC only, 15- or 20-amp fused electrical supply (or circuit breaker) is required. (A time-delay fuse or circuit breaker is recommended.) It is recommended that a separate circuit serving only this appliance be provided.

GROUNDING INSTRUCTIONS

■ **For all cord connected appliances:**

The microwave oven must be grounded. In the event of an electrical short circuit, grounding reduces the risk of electric shock by providing an escape wire for the electric current. The microwave oven is equipped with a cord having a grounding wire with a grounding plug. The plug must be plugged into an outlet that is properly installed and grounded.

WARNING: Improper use of the grounding plug can result in a risk of electric shock. Consult a qualified electrician or serviceman if the grounding instructions are not completely understood, or if doubt exists as to whether the microwave oven is properly grounded.

Do not use an extension cord. If the power supply cord is too short, have a qualified electrician or serviceman install an outlet near the microwave oven.

SAVE THESE INSTRUCTIONS

This device complies with Part 18 of the FCC Rules.

PARTS AND FEATURES

This manual may cover several different models. The model you have purchased may have some or all of the features shown here. The appearance of your particular model may differ slightly from the illustrations in this manual.

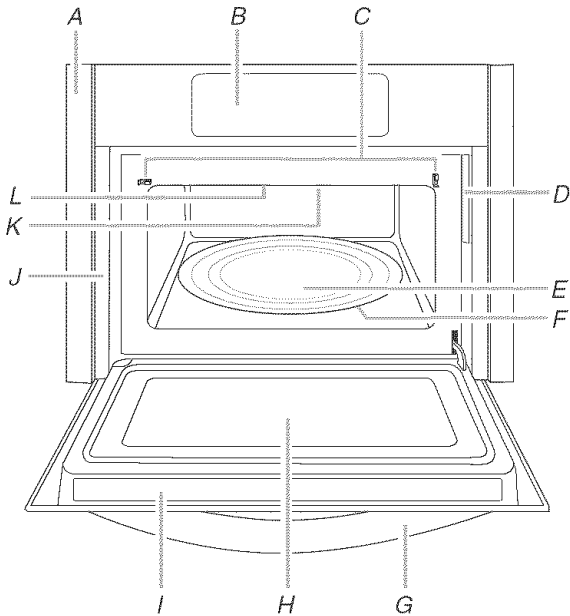

- A. Trim
- B. Control panel
- C. Door safety lock system
- D. Model and serial number plate
- E. Glass turntable
- F. Turntable support, rollers and hub
- G. Door handle
- H. Metal shielded window
- I. Cooking guide label
- J. Frame
- K. Microwave oven light (inaccessible -- in ceiling)
- L. Microwave inlet cover

Turntable

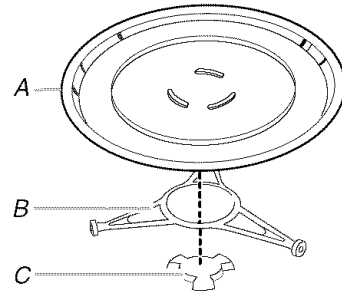

- A. Turntable
- B. Support
- C. Hub

The turntable rotates in both directions to help cook food more evenly. Do not operate the microwave oven without having the turntable in place. See "Assistance or Service" to reorder any of the parts.

To Install: The support and hub are preassembled and installed in the microwave oven. Place the turntable on the support. Fit the raised, curved lines in the center of the turntable bottom between the three spokes of the hub. The rollers on the support should fit inside the turntable bottom ridge.

MICROWAVE OVEN CONTROL

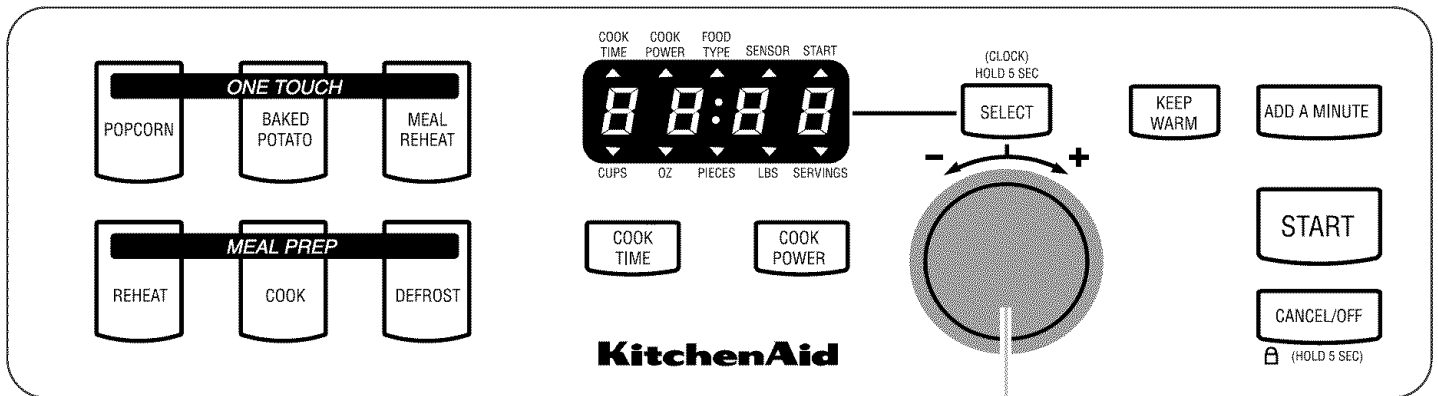

A

A. Dial

Display

When power is first supplied to the microwave oven, a “:” will blink in the display. Touch CANCEL/OFF to stop the blinking. If the “:” blinks in the display at any other time, a power failure has occurred. Touch CANCEL/OFF and reset the clock if needed.

When the microwave oven is in use, the display shows cooking power, quantities, weights and/or prompts. When the microwave oven is not in use, the display shows the time of day. When the microwave oven is sensing, sensor animation (clockwise “racetrack” movement) will be active in the display.

Start

The START pad begins any function. If non-sensor cooking is interrupted, touching START will resume the preset cycle. If sensor cooking is interrupted, touching START will resume the cycle only if the sensor already has estimated the cook time, and the countdown is active in the display.

Add a Minute

Cook time may be added in 1-minute increments, up to 99 minutes, by touching ADD A MINUTE.

Touching ADD A MINUTE during a cook cycle will add 1 minute of cook time at the current cook power.

Touching ADD A MINUTE when the microwave oven is not in use, or after a cook cycle has ended, will start the microwave oven for 1 minute of cook time at 100% cook power.

Cancel/Off

The CANCEL/OFF pad clears any incorrect command and cancels most functions except for the Control Lock and Demo Mode. It will not erase the time of day unless the display is in clock-setting mode. See “Clock” section.

The microwave oven will also turn off when the door is opened. Close the door and touch START to resume the cycle. If sensor cooking is interrupted by opening the door while the sensor is estimating the cook time, and the sensor animation is active in the display, the cycle will be canceled.

Dial

Use the dial to select options, set the clock, set cook time and cook power, select food type and amount/weight, and adjust doneness.

To Use: Push dial and release to pop it out. Repeat to return dial to its flush position after each use to prevent breakage of the dial.

Select

Use the SELECT pad to select a chosen function and to set the following options:

- Select a setting or food type, and go to the next step.
- Set or cancel clock. See “Clock” section.
- Set weight measurements to oz or lbs.
- Set amount measurements to pieces, cups or servings.

See “Meal Prep” sections for details on using the SELECT pad with the automatic cooking, reheating and defrosting programs.

Clock

This is a 12-hour clock.

To Set:

1. Touch and hold SELECT pad for 5 seconds.
“12:00” will appear in the display, with the hour (12) flashing. If you are changing the time, the current set time will appear, with the hour flashing.
2. Turn the dial to set the hour.
3. Touch SELECT or START.
The “minutes” digits will flash in the display.
4. Turn the dial to set the minutes.
5. Touch SELECT or START to complete the setting.

To Cancel Clock:

1. Touch and hold SELECT pad for 5 seconds.
The clock-setting display will show.
2. Touch CANCEL/OFF.
The “:” will appear in the display.

The next time the clock is set, “12:00” will appear in the display when the clock-setting mode is entered.

Tones

Tones are audible signals, indicating the following:

One tone

- Valid entry (short tone)

Two tones

- Reminder, repeat each minute after the end-of-cycle tones
- Hidden feature has been entered or exited

Three tones

- Invalid entry

Four tones

- End of cycle
- End of warming cycle
- Between cooking cycle and warming cycle

Fifteen tones

- Error

The tones cannot be turned off, and the volume cannot be changed.

Demo Mode

The Demo Mode is ideal for learning how to use the microwave oven. When set, functions can be entered without actually turning on the magnetron. The microwave oven light will come on, the fan will run, and the turntable will rotate. When the microwave oven is turned on while in Demo Mode, “no” and then “HEAT” will appear in the display.

To Turn On/Off: The microwave oven must be off. Open the door, then touch and hold COOK for 5 seconds. Three short tones will sound. Repeat to exit Demo Mode.

Control Lock

The Control Lock shuts down the control panel pads to prevent unintended use of the microwave oven.

When the control panel is locked, none of the controls will function. If a control pad is touched, "LOC" will appear in the display and invalid entry tones will sound.

To Lock/Unlock Control: Before locking, make sure the microwave oven is off. Touch and hold CANCEL/OFF for 5 seconds until 2 tones sound. Repeat to unlock the controls.

Cooling Fan

Depending on the length of the cooking cycle, the cooling fan may continue to run after that cycle has ended. This is normal, and helps eliminate moisture that may accumulate inside the microwave oven before the door is opened.

While the fan is running, "COOL" will appear in the display. The fan will turn off automatically.

MICROWAVE OVEN USE

A magnetron in the oven produces microwaves which reflect off the metal floor, walls and ceiling and pass through the turntable and appropriate cookware to the food. Microwaves are attracted to and absorbed by fat, sugar and water molecules in the food, causing them to move, producing friction and heat which cooks the food.

- Do not lean on or allow children to swing on the microwave oven door.
 - Do not operate microwave oven when it is empty.
 - The turntable must be in place and correct side up when microwave oven is in use. Do not use if turntable is chipped or broken. See "Assistance or Service" section to reorder.
 - Baby bottles and baby food jars should not be heated in microwave oven.
 - Clothes, flowers, fruit, herbs, wood, gourds, paper, including brown paper bags and newspaper, should not be dried in microwave oven.
 - Do not use the microwave oven for canning, sterilizing or deep frying. The microwave oven cannot maintain appropriate temperatures.
 - Paraffin wax will not melt in the microwave oven because it does not absorb microwaves.
 - Use oven mitts or pot holders when removing containers from microwave oven.
 - Do not overcook potatoes. At the end of the recommended cook time, potatoes should be slightly firm. Let potatoes stand for 5 minutes. They will finish cooking while standing.
 - Do not cook or reheat whole eggs inside the shell. Steam buildup in whole eggs may cause them to burst. Cover poached eggs and allow a standing time.
-

Food Characteristics

When microwave cooking, the amount, size and shape, starting temperature, composition and density of the food affect cooking results.

Amount of Food

The more food heated at once, the longer the cook time. Check for doneness and add small increments of time if necessary.

Size and Shape

Smaller pieces of food will cook more quickly than larger pieces, and uniformly shaped foods cook more evenly than irregularly shaped food.

Starting Temperature

Room temperature foods will heat faster than refrigerated foods, and refrigerated foods will heat faster than frozen foods.

Composition and Density

Foods high in fat and sugar will reach a higher temperature, and will heat faster than other foods. Heavy, dense foods, such as meat and potatoes, require a longer cook time than the same size of a light, porous food, such as cake.

Cooking Guidelines

Covering

Covering food helps retain moisture, shorten cook time and reduce spattering. Use the lid supplied with cookware. If a lid is not available, wax paper, paper towels or plastic wrap approved for microwave ovens may be used. Plastic wrap should be turned back at one corner to provide an opening to vent steam. Condensation on the door and cavity surfaces is normal during heavy cooking.

Stirring and Turning

Stirring and turning redistribute heat evenly to avoid overcooking the outer edges of food. Stir from outside to center. If possible, turn food over from bottom to top.

Arranging

If heating irregularly shaped or different sized foods, arrange the thinner parts and smaller sized items toward the center. If cooking several items of the same size and shape, place them in a ring pattern, leaving the center of the ring empty.

Piercing

Before heating, use a fork or small knife to pierce or prick foods that have a skin or membrane, such as potatoes, egg yolks, chicken livers, hot dogs, and sausage. Prick in several places to allow steam to vent.

Shielding

Use small, flat pieces of aluminum foil to shield the thin pieces of irregularly shaped foods, bones and foods such as chicken wings, leg tips and fish tail. See "Aluminum Foil and Metal" first.

Standing Time

Food will continue to cook by the natural conduction of heat even after the microwave cooking cycle ends. The length of standing time depends on the volume and density of the food.

Cookware and Dinnerware

Cookware and dinnerware must fit on the turntable. Always use oven mitts or pot holders when handling because any dish may become hot from heat transferred from the food. Do not use cookware and dinnerware with gold or silver trim. Use the following chart as a guide, then test before using.

MATERIAL	RECOMMENDATIONS
Aluminum Foil, Metal	See "Aluminum Foil and Metal" section.
Browning Dish	Bottom must be at least 3/16" (5 mm) above the turntable. Follow manufacturer's recommendations.
Ceramic Glass, Glass	Acceptable for use.
China, Earthenware	Follow manufacturer's recommendations.
Melamine	Follow manufacturer's recommendations.
Paper: Towels, Dinnerware, Napkins	Use nonrecycled and those approved by the manufacturer for microwave oven use.
Plastic: Wraps, Bags, Covers, Dinnerware, Containers	Use those approved by the manufacturer for microwave oven use.
Pottery and Clay	Follow manufacturer's recommendations.
Styrofoam*	Do not use in microwave oven.
Straw, Wicker, Wooden Containers	Do not use in microwave oven.
Wax Paper	Acceptable for use.

To Test Cookware or Dinnerware for Microwave Use:

1. Put cookware or dinnerware in microwave oven with 1 cup (250 mL) of water beside it.
2. Cook at 100% cooking power for 1 minute.

Do not use cookware or dinnerware if it becomes hot and the water stays cool.

Aluminum Foil and Metal

Always use oven mitts or pot holders when removing dishes from the microwave oven.

Aluminum foil and some metal can be used in the microwave oven. If not used properly, arcing (a blue flash of light) can occur and cause damage to the microwave oven.

OK for Use

Racks and bakeware supplied with the microwave oven (on some models), aluminum foil for shielding, and approved meat thermometers may be used with the following guidelines:

- Do not allow aluminum foil or metal to touch the inside cavity walls, ceiling or floor.
- Always use the turntable.
- Do not allow contact with another metal object during cooking.

Do Not Use

Metal cookware and bakeware, gold, silver, pewter, non-approved meat thermometers, skewers, twist ties, foil liners such as sandwich wrappers, staples and objects with gold or silver trim or a metallic glaze should not be used in the microwave oven.

Cooking Power

Many recipes for microwave cooking specify which cooking power to use by percent or name. For example, 70%=Medium-High.

Use the following chart as a general guide for the suggested cooking power of specific foods.

PERCENT/NAME	USE
100%, High (default setting)	Quick heating convenience foods and foods with high water content, such as soups, beverages and most vegetables.
90%	Cooking small, tender pieces of meat, ground meat, poultry pieces and fish fillets. Heating cream soups.
80%	Heating rice, pasta or casseroles. Cooking and heating foods that need a cook power lower than high. For example, whole fish and meat loaf.
70%, Medium-High	Reheating a single serving of food.
60%	Cooking sensitive foods such as cheese and egg dishes, pudding and custards. Cooking non-stirrable casseroles, such as lasagna.
50%, Medium	Cooking ham, whole poultry and pot roasts. Simmering stews.
40%	Melting chocolate. Heating bread, rolls and pastries.
30%, Medium-Low, Defrost	Defrosting bread, fish, meats, poultry and precooked foods.
20%	Softening butter, cheese, and ice cream.
10%, Low	Taking chill out of fruit.

Cook Time Set

Cook time may be set in the following increments, in minutes and seconds:

INCREMENT	TIME SETTING
0:05	0:05-1:00
0:15	1:15-3:00
0:30	3:30-6:00
1:00	7:00-30:00
5:00	35:00-90:00

To Use:

1. Touch COOK TIME, then turn the dial to desired cook time
or
touch COOK TIME repeatedly to increase cook time. See chart for time increments.
If cooking at 100% power, skip to Step 3.
2. Touch COOK POWER, then turn the dial to the desired power level
or
touch COOK POWER repeatedly to increase cook power.
3. Touch START.
The display will count down the cook time.
When the cycle ends, "END" will appear in the display, and the end-of-cycle tones will sound, followed by reminder tones.
4. Touch CANCEL/OFF or open the door to clear the display and/or stop reminder tones.

The cook time may be changed at any time after touching START. The dial may be used to increase or reduce cook time. The COOK TIME pad will only add time.

Doneness

For most automatic cooking functions, the doneness of a particular food item can be adjusted by turning the dial. Increasing or decreasing the doneness adds time to, or subtracts time from the cooking cycle.

For up to 20 seconds after cooking has started, turning the dial will change the doneness value. There are 5 settings: default, "2," "1," "-1" and "-2." The display shows "----" for the default setting.

Doneness cannot be adjusted for Defrost functions or for the Popcorn function.

Meal Prep Cook

Times and cooking power have been preset for certain microwavable foods. Use the following chart as a guide.

FOOD	NO.	QUANTITY/INSTRUCTIONS
Canned Vegetables	1	1-4 cups (250 mL-1 L)/ Place in microwavable container. Cover with plastic wrap and vent. Stir and let stand 2-3 minutes after cooking.
Cereal	2	1-4 servings/ Use instant cereal. Follow package directions. Use microwavable bowls with high sides.
Boneless Chicken Breasts	3	1-4 pieces, 6 oz (170 g) each/ Place in microwavable dish. Add 2 tbs (30 mL) water. Cover with plastic wrap and vent. Let stand in microwave oven for 3 minutes after cooking.
Fresh Vegetables	4	1-4 cups (250 mL-1 L)/ Place in microwavable container. Add 2-4 tbs (30-60 mL) water. Cover with plastic wrap and vent. Stir and let stand 2-3 minutes after cooking.
Frozen Entrée	5	10 or 20 oz (283 or 567 g)/ Remove from package. Loosen cover on three sides. If entree is not in microwavable container, place on plate, cover with plastic wrap and vent.
Frozen Vegetables	6	1-4 cups (250 mL-1 L)/ Remove from package. Place in microwavable container. Cover with plastic wrap and vent. Stir and let stand 2-3 minutes after cooking.
Rice	7	0.5-2 cups (125-500 mL)/ Use dish with loose-fitting lid. Let stand 5 minutes after cooking.

To Use the Cook Control:

1. Touch COOK.
The display will show "1" for the first food type.
2. Turn the dial or repeatedly touch COOK to scroll through the food types until the number of the desired food type is displayed. See chart.
Wait 5 seconds, or touch START or SELECT.
The display will prompt for amount or weight.
3. Turn the dial to the desired amount or weight.
4. Touch START.
Doneness may be adjusted within 20 seconds after touching START by turning the dial.
The display will count down the cook time.
When the cycle ends, "END" will appear in the display, and the end-of-cycle tones will sound, followed by reminder tones.
5. Touch CANCEL/OFF or open the door to clear the display and/or stop reminder tones.

Meal Prep Reheat

Times and cooking power have been preset for reheating specific food types. Use the following chart as a guide.

FOOD	NO.	QUANTITY/INSTRUCTIONS
Baked Goods	1	1-6 pieces, 2 oz (57 g) each*/ Place on paper towel.
Beverage	2	1 or 2 cups, 8 oz (250 mL) each/ Do not cover. The diameter of the cup's opening will affect how the liquid heats. Beverages in cups with smaller openings may heat faster.
Casserole (refrigerated)	3	1-4 cups (250 mL-1 L)/ Place in microwavable container and cover with plastic wrap. Stir and let stand 2-3 minutes after reheating.
Pizza (refrigerated)	4	1-3 pieces, 3 oz (85 g) each/ Place on paper towel.
Sauce	5	1-4 cups (250 mL-1 L)/ Place in microwavable container. Cover with plastic wrap and vent. Stir and let stand 2-3 minutes after reheating.
Soup	6	1-4 cups (250 mL-1 L)/ Place in microwavable container. Cover with plastic wrap and vent. Stir and let stand 2-3 minutes after reheating.

*For smaller rolls, 2 rolls may be counted as 1 piece.

To Use the Reheat Control:

1. Touch REHEAT.
The display will show "1" for the first food type.
2. Turn the dial or repeatedly touch REHEAT to scroll through the food types until the number of the desired food type is displayed. See chart.
Wait 5 seconds, or touch START or SELECT.
The display will prompt for amount or weight.
3. Turn the dial to the desired amount or weight.
4. Touch START.
Doneness may be adjusted within 20 seconds after touching START by turning the dial.
The display will count down the reheat time.
When the cycle ends, "END" will appear in the display, and the end-of-cycle tones will sound, followed by reminder tones.
5. Touch CANCEL/OFF or open the door to clear the display and/or stop reminder tones.

Meal Prep Defrost

The automatic defrost function can be used, or the microwave oven can be manually set to defrost.

- Food should be 0°F (-18°C) or colder at defrosting for optimal results.
- Unwrap foods and remove lids (e.g. fruit juice containers) before defrosting.
- Shallow packages will defrost more quickly than deep blocks.
- Separate food pieces as soon as possible during or at the end of cycle for more even defrosting.
- Use small pieces of aluminum foil to shield parts of food such as chicken wings, leg tips and fish tails. See "Aluminum Foil and Metal" first.

The automatic defrost function should not be used for food left outside the freezer for more than 20 minutes and frozen ready-made food.

Times and cooking power have been preset for defrosting certain food types. Use the following chart as a guide.

FOOD	NO.	QUANTITY/INSTRUCTIONS
Bread (dinner rolls, muffins, buns, bread slices, bread loaf)	1	0.1-2.0 lbs (45-900 g)/ Place on paper towel. Do not cover.
Fish/Seafood (fillets, steaks, whole shellfish)	2	0.2-4.4 lbs (90 g-2 kg)/ Remove wrap and place in microwavable baking dish. Do not cover.
Meat (ground, steaks, roasts, stew, chops, ribs)	3	0.2-6.6 lbs (90 g-3 kg)/ Remove wrap and place in microwavable baking dish. Do not cover.
Poultry (whole chicken, chicken pieces, Cornish hens, turkey breast)	4	0.2-6.6 lbs (90 g-3 kg)/ Remove wrap and place breast side up in microwavable baking dish. Do not cover.

To Use the Defrost Control:

1. Touch DEFROST.
The display will show "1" for the first food type.
2. Turn the dial or repeatedly touch DEFROST to scroll through the food types until the number of the desired food type is displayed. See chart.
Wait 5 seconds, or touch START or SELECT.
The display will ask for weight.
3. Turn the dial to the desired weight.
4. Touch START.
The display will count down the defrost time.
When the cycle ends, "END" will appear in the display, and the end-of-cycle tones will sound, followed by reminder tones.
5. Touch CANCEL/OFF or open the door to clear the display and/or stop reminder tones.

To Defrost Manually: Follow instructions in "Cooking" section, and use 30% cooking power. See "Cooking Power" chart.

One Touch Sensor Cooking

A sensor in the microwave oven detects humidity released from the food and automatically sets a cooking time based on the selected pad.

Use the following chart as a guide for the ONE TOUCH pads.

FOOD	SERVING SIZE	INSTRUCTIONS
Popcorn*	3.0-3.5 oz (85-99 g) 1.75 oz (50 g)	Pop only one package at a time.
Baked Potato	1-4 medium, 10-13 oz (283-369 g) each, similar in size	Pierce each one several times with a fork. Place on paper towel, around turntable edges, at least 1" (2.5 cm) apart. Let stand 5 minutes after cooking.
Meal Reheat	1 serving (1 plate), 8-16 oz (227-454 g)	Place food on plate, cover with plastic wrap and vent.

*Do not use regular paper bags or glassware. Listen for popping to slow to 1 pop every 1 or 2 seconds, then stop the cycle. Do not try to pop unpopped kernels. Use fresh bags of popcorn for optimal results. Cooking results may vary by brand and fat content. For bag sizes not listed in this section, follow directions on package. If using a microwave popcorn popper, follow manufacturer's instructions.

To Use One Touch Sensor Cooking:

Before using, make sure the microwave oven has been plugged in for at least 3 minutes, the room temperature is not above 95°F (35°C), and the microwave oven cavity is dry.

REMEMBER: If the door is opened while the sensor is "sensing" (sensor animation active in the display), the sensor cycle will be canceled.

To Use Baked Potato and Meal Reheat: Place item on turntable and close the door.

1. Touch BAKED POTATO or MEAL REHEAT.

The microwave oven will automatically turn on. The sensor animation will briefly appear, followed by the estimated remaining cook time.

Doneness may be adjusted during the first 20 seconds of cooking by turning the dial. See "Doneness" section.

The remaining cook time may be recalculated several times during cooking. Each time, the sensor animation will appear for 3 seconds, followed by the new remaining time.

When the cycle ends, "END" will appear in the display, and the end-of-cycle tones will sound, followed by reminder tones.

2. Touch CANCEL/OFF or open the door to clear the display and/or stop reminder tones.

To Use Popcorn: Place popcorn bag on the turntable, correct side up, as indicated on the package.

1. Touch POPCORN.

The display will show "3.0-" followed by "3.5." Turning the dial or touching POPCORN again will change the selection to "1.75." See chart for details.

2. Touch START.

The sensor animation will appear in the display, and the remaining popping time may be displayed periodically during the cycle.

When the cycle ends, "END" will appear in the display, and the end-of-cycle tones will sound, followed by reminder tones.

3. Touch CANCEL/OFF or open the door to clear the display and/or stop reminder tones.

Keep Warm

WARNING

Food Poisoning Hazard

Do not let food sit in oven more than one hour before or after cooking.

Doing so can result in food poisoning or sickness.

Hot cooked food can be kept warm in the microwave oven. Keep Warm can be used by itself or can be programmed to follow a cooking cycle.

To Use:

Put hot cooked food in the oven. Cover plates of food and foods that were cooked covered. Pastries, pies, turnovers, etc. should remain uncovered.

1. Touch KEEP WARM.

The display will show "60:00," which is the maximum default warming time.

2. Adjust the warming time, if desired, by turning the dial.

3. Touch START.

The display will count down the warming time, and the Cook Time indicator will flash.

Warming time may be adjusted at any time during the Keep Warm cycle by turning the dial.

The 10% cook power cannot be changed during the Keep Warm cycle.

When the cycle ends, the end-of-cycle tones will sound, and the display will return to the time of day mode.

To Set at End of Cycle: During any cooking function, touch KEEP WARM. (There will be no visible indicator that the Keep Warm function has been programmed.) When the current cooking cycle has ended, the end-of-cycle tones will sound, and then the Keep Warm cycle will automatically start for the maximum default warming time. The display will count down the warming time, and the Cook Time indicator will flash. At the end of the warming cycle, the end-of-cycle tones will sound, and the display will return to the time of day mode.

To Warm Manually: Follow instructions in "Cook Time Set" section, and use 10% cooking power. See "Cooking Power" chart.

MICROWAVE OVEN CARE

General Cleaning

IMPORTANT: Before cleaning, make sure all controls are off and the oven is cool. Always follow label instructions on cleaning products. Soap, water and a soft cloth or sponge are suggested first unless otherwise noted.

OVEN CAVITY

Do not use soap-filled scouring pads, abrasive cleaners, steel-wool pads, gritty washcloths or some recycled paper towels. Damage may occur.

On stainless steel models, rub in direction of grain to avoid damaging.

The area where the oven door and frame touch when closed should be kept clean.

Average soil

- Mild, nonabrasive soaps and detergents:
Rinse with clean water and dry with soft, lint-free cloth.

Heavy soil

- Mild, nonabrasive soaps and detergents:
Heat 1 cup (250 mL) of water for 2 to 5 minutes in oven. Steam will soften soil. Rinse with clean water and dry with soft, lint-free cloth.

Odors

- Lemon juice or vinegar:
Heat 1 cup (250 mL) of water with 1 tbs (15 mL) of either lemon juice or vinegar for 2 to 5 minutes in oven.

Microwave Inlet Cover

The microwave inlet cover (see “Parts and Features”) should be kept clean to avoid arcing and oven damage.

- Wipe with wet cloth.

CONTROL PANEL

Do not use abrasive cleaners, steel-wool pads, gritty washcloths or some paper towels. Damage may occur.

Make sure dial is pushed into its flush position.

- Glass cleaner and soft cloth or sponge: Apply glass cleaner to soft cloth or sponge, not directly onto panel.

OVEN DOOR AND EXTERIOR

The area where the oven door and frame touch when closed should be kept clean.

- Mild, nonabrasive soaps and detergents:
Rinse with clean water and dry with soft, lint-free cloth.
- Glass cleaner and paper towels or nonabrasive plastic scrubbing pad:
Apply glass cleaner to towel, not directly to surface.

Stainless Steel (on some models)

Do not use soap-filled scouring pads, abrasive cleaners, steel-wool pads, gritty washcloths or some paper towels. Damage may occur.

Rub in direction of grain to avoid damaging.

- Stainless Steel Cleaner & Polish (not included):
See “Assistance or Service” section to order.
- Liquid detergent or all-purpose cleaner:
Rinse with clean water and dry with soft, lint-free cloth.
- Vinegar for hard water spots

TURNTABLE

Replace turntable immediately after cleaning. Do not operate the microwave oven without the turntable in place.

- Mild cleanser and scouring pad
- Dishwasher

TROUBLESHOOTING

Try the solutions suggested here first in order to avoid the cost of an unnecessary service call.

Nothing will operate

- **Has a household fuse blown, or has a circuit breaker tripped?**
Replace the fuse or reset the circuit.
 - **Is the appliance wired properly?**
See Installation Instructions provided with your microwave oven.
-

Oven will not operate

- **Is the door completely closed?**
Firmly close door.
 - **Is a spacer (on some models) attached to the inside of the door?**
Remove spacer, then firmly close door.
 - **Is the electronic oven control set correctly?**
See "Microwave Oven Control" section.
 - **On some models, is the Control Lock set?**
See "Control Lock" section.
 - **On some models, is the Demo Mode in use?**
See "Demo Mode" section.
 - **Is the magnetron working properly?**
Try to heat 1 cup (250 mL) of cold water for 2 minutes at 100% cooking power. If water does not heat, call for service. See "Assistance or Service" section.
-

Oven makes humming noise

- This is normal and occurs when the power supply switches the magnetron on and off.
-

Oven door looks wavy

- This is normal and will not affect performance.
-

Turntable will not operate

- **Is the turntable properly in place?**
Make sure turntable is correct side up and is sitting securely on the turntable support.
 - **Is the turntable support operating properly?**
Remove turntable. Remove and replace turntable support. Replace turntable. Place 1 cup (250 mL) of water on the turntable, then restart oven. If it still is not working, call for service. See "Assistance or Service" section. Do not operate the oven without turntable and turntable support working properly.
-

Turntable alternates directions

- This is normal and depends on motor rotation at beginning of cycle.
-

Display shows messages

- **Is the display showing an "Oven Status" screen, with a letter/number code and instruction to inform KitchenAid?**
The oven has detected an internal problem. It has run a self-checking program and displayed the error. Call for service. See "Assistance or Service" section.
-

Display shows time countdown, but is not operating

- **On some models, is the Timer in use?**
See "Timer" section.
 - **On some models, is the Demo Mode in use?**
See "Demo Mode" section.
-

Tones are not sounding

- **On some models, are tones turned off?**
See "Tones" section.
-

Fan running slower than usual

- **Has the oven been stored in a cold area?**
The fan will run slower until the oven warms up to normal room temperature.
-

Cooking times seem too long

- **Is the cooking power set properly?**
See "Cooking Power" section.
 - **Are large amounts of food being heated?**
Larger amounts of food need longer cooking times.
 - **Is the incoming voltage less than specified in "Microwave Oven Safety?"**
Have a qualified electrician check the electrical system in the home.
-

Interference with radio, TV, cordless phone, etc.

- **Is the microwave oven plugged into the same outlet?**
Try a different outlet.
 - **Is the radio or TV receiver near the microwave oven?**
Move the receiver away from the microwave oven, or adjust the radio or TV antenna.
 - **Are the microwave oven door and sealing surfaces clean?**
Make sure these areas are clean.
 - **Is the cordless phone frequency 2.4 GHz?**
Some 2.4 GHz-based cordless phones and home wireless networks may experience static or noise while the microwave oven is on. Use a corded phone or a different frequency cordless phone, or avoid using these items during oven operation.
-

ASSISTANCE OR SERVICE

Before calling for assistance or service, please check "Troubleshooting." It may save you the cost of a service call. If you still need help, follow the instructions below.

When calling, please know the purchase date and the complete model and serial number of your appliance. This information will help us to better respond to your request.

If you need replacement parts

If you need to order replacement parts, we recommend that you use only factory specified parts. These factory specified parts will fit right and work right because they are made with the same precision used to build every new KITCHENAID® appliance.

To locate factory specified parts in your area, call us or your nearest KitchenAid designated service center.

In the U.S.A.

Call the KitchenAid Customer eXperience Center toll free:

1-800-422-1230.

Our consultants provide assistance with:

- Features and specifications on our full line of appliances.
- Installation information.
- Accessory and repair parts sales.
- Specialized customer assistance (Spanish speaking, hearing impaired, limited vision, etc.).
- Referrals to local dealers, repair parts distributors, and service companies. KitchenAid designated service technicians are trained to fulfill the product warranty and provide after-warranty service, anywhere in the United States.

To locate the KitchenAid designated service company in your area, you can also look in your telephone directory Yellow Pages.

For further assistance

If you need further assistance, you can write to KitchenAid with any questions or concerns at:

KitchenAid Brand Home Appliances
Customer eXperience Center
553 Benson Road
Benton Harbor, MI 49022-2692

Please include a daytime phone number in your correspondence.

Replacement Parts

Turntable
Part No. 8205540

Turntable Support and Rollers
Part No. 8205539

Turntable Hub
Part No. 8205539

Stainless Steel Cleaner & Polish
Part No. 8171420

KITCHENAID® BUILT-IN MICROWAVE OVEN WARRANTY

ONE-YEAR FULL WARRANTY

For one year from the date of purchase, when this appliance is operated and maintained according to instructions attached to or furnished with the product, KitchenAid will pay for factory specified parts and repair labor costs to correct defects in materials or workmanship. Service must be provided by a KitchenAid designated service company.

SECOND THROUGH FIFTH YEAR LIMITED WARRANTY ON MAGNETRON TUBE, ELECTRIC OVEN ELEMENT AND SOLID STATE TOUCH CONTROL SYSTEM

In the second through fifth years from the date of purchase, when this appliance has been operated and maintained according to instructions attached to or furnished with this product, KitchenAid will pay for factory specified parts for the microwave magnetron tube, any electric oven element and the solid state touch control system to correct defects in materials or workmanship.

SECOND THROUGH TENTH YEAR LIMITED WARRANTY ON STAINLESS STEEL OVEN CAVITY/INNER DOOR

In the second through tenth years from date of purchase, when this appliance is operated and maintained according to instructions attached to or furnished with this product, KitchenAid will pay for factory specified parts for the stainless steel oven cavity/inner door if the part rusts through due to defects in materials or workmanship.

KitchenAid will not pay for:

1. Service calls to correct the installation of your appliance, to instruct you how to use your appliance, to replace house fuses or correct house wiring, or to replace owner-accessible light bulbs.
 2. Repairs when your appliance is used in other than normal, single-family household use.
 3. Pickup and delivery. Your appliance is designed to be repaired in the home.
 4. Damage resulting from accident, alteration, misuse, abuse, fire, flood, improper installation, acts of God or use of products not approved by KitchenAid.
 5. Repairs to parts or systems resulting from unauthorized modifications made to the appliance.
 6. Replacement parts or repair labor costs for units operated outside the United States.
 7. Any labor costs during the limited warranty periods.
-

KITCHENAID SHALL NOT BE LIABLE FOR INCIDENTAL OR CONSEQUENTIAL DAMAGES.

Some states do not allow the exclusion or limitation of incidental or consequential damages, so this exclusion or limitation may not apply to you. This warranty gives you specific legal rights, and you may also have other rights which vary from state to state.

Outside the 50 United States, this warranty does not apply. Contact your authorized KitchenAid dealer to determine if another warranty applies.

If you need service, first see the "Troubleshooting" section of this book. After checking "Troubleshooting," additional help can be found by checking the "Assistance or Service" section or by calling the KitchenAid Customer eXperience Center, **1-800-422-1230** (toll-free), from anywhere in the U.S.A.

10/04

Keep this book and your sales slip together for future reference. You must provide proof of purchase or installation date for in-warranty service.

Write down the following information about your appliance to better help you obtain assistance or service if you ever need it. You will need to know your complete model number and serial number. You can find this information on the model and serial number label/plate, located on your appliance as shown in the "Parts and Features" section.

Dealer name _____
Address _____
Phone number _____
Model number _____
Serial number _____
Purchase date _____

