



AQ-MF-1

Under Sink Water Filter

Claryum® Direct Connect

Owner's Manual



Meet clean, healthy water. Your new Aquasana system features Claryum® filtration that removes up to 99% of 78 contaminants including lead, PFOA/PFOS, pesticides, pharmaceuticals, and chlorine.*

Enjoy the peace of mind that comes from knowing our award-winning filter technology is working for you.

AQ-MF-1

Under Sink Water Filter

Claryum® Direct Connect

TABLE OF CONTENTS

Box Contents	1
Use & Care	2
Installation Steps.....	3-6
Filter Replacement.....	6
Performance & Certifications	7
Warranty	8
Water for Life® Program.....	9

System Head and Mounting Bracket

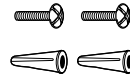

Mounting Screws and Anchors (12)

System Cartridge

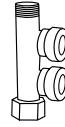

Dual Port Adapter



3' 3/8" Tubing (2)



Cartridge Mounting Brackets (2)



Quick Connect Elbows (2) (if needed)

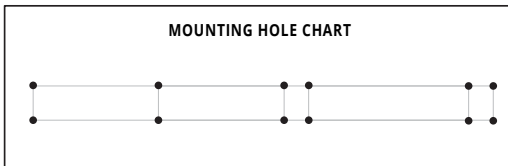

Mounting Hole Chart

Before beginning installation, please ensure all parts listed are present. If any part is missing or damaged, do not attempt to install the filter. Please contact Customer Support for replacement parts at **866-662-6885**.

Tools recommended for installation:

- Variable Speed Drill w/ 1/8" Bit (7/32" bit if using anchors in drywall)
- Adjustable Wrench
- Philips Head Screwdriver
- Level
- Pencil
- Measuring Tape
- Hammer
- Utility Knife
- Safety Glasses

Please read all precautions and instructions carefully before using.

Use and Care

- Replace the filter every 784 gallons (approximately every 6 months) for continued contaminant removal and system performance. Always use genuine, certified Aquasana replacements.
- Upon installation, write the date of installation on the filter label as a reminder of when you will need to replace the filter.
- To clean your system, wipe down the exterior with a damp cloth.
- **Do not** use any strong or abrasive cleaning agent or solvent cleaner.

Important Safeguards

- **Do not** install this filter where the line pressure may exceed 125 psi. The operating pressure range for this filter is between 10psi – 125psi.
- Install on COLD water lines only (35° – 100°F).
- **Use caution** when installing the unit on a cabinet wall that backs

up to a dishwasher. Screws could exceed cabinet width.

- It is recommended your system be installed inside and out of direct sunlight. The unit must be protected from both direct sunlight and freezing temperatures.
- Filter usage must comply with all state and local laws.
- Do not operate without the filters installed.
- Do not use with water that is microbiologically unsafe or of unknown water quality without adequate disinfection before or after the system.
- Water with sediment may require a filter change sooner than 784 gallons or 6 months.



Scan to view the Claryum® Direct Connect product and installation videos.

Tips for Quick-Connect Fittings

To Connect:

1. Measure 1/2" from the end of the tube and mark with a permanent marker.
2. Create a clean square edge for each tube by cutting the end with a utility knife.

Lock Sleeve

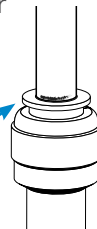

To Disconnect:

1. Gently push the "Lock Sleeve" down with two fingers.
2. Pull tube to remove.

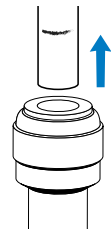
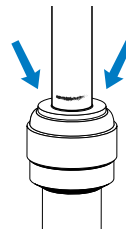

Installation Options

1. Horizontal floor mount (mount the system to the floor of your cabinet)
2. Horizontal wall mount
3. Vertical mount

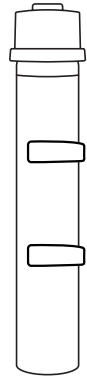
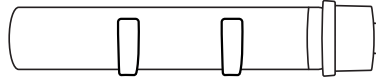

① Setup

Lightly place system head onto cartridge (do not fully attach) and place under sink to determine a suitable area under the sink to mount the system.

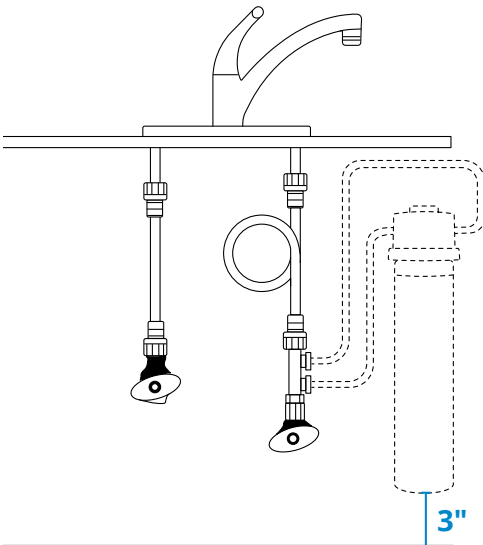
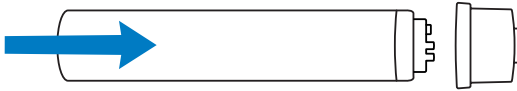

Three (3) inches of clearance from the base of the filter is needed for easy cartridge replacement.

The system head must be installed less than three (3) feet from the cold water supply line.

NOTE: Remove system head before proceeding to Step 2.

2 Mount System Head

- A. Place system head in desired location and use a pencil to mark the top right mounting hole. Use the mounting hole chart provided, a level, and measuring tape to mark the remaining holes. When using the mounting chart, pre-punch holes in the paper or press the pencil through the center of the hole while marking.
- B. Drill pilot holes with a 1/8" drill bit.

NOTE: If installing on drywall, use a 7/32" drill bit to drill the holes for plastic anchors. Carefully tap anchors into the drilled holes with a hammer.

- C. Using a Philips head screwdriver, mount the system head and cartridge mounting brackets using the provided screws. Ensure that the bracket marked P/N-2 is closest to the system head.
- D. Place cartridge into brackets and connect to system head by turning to the right.

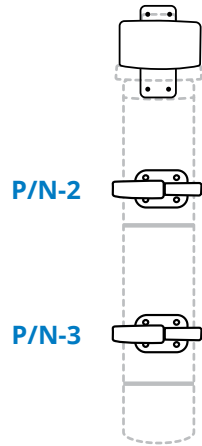
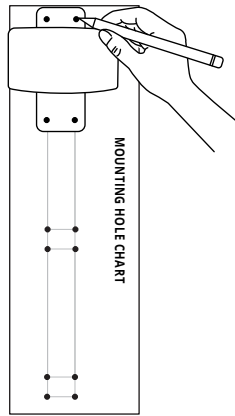

3 Disconnect Water Line and Connect Tubing

- A. Place a bucket under cold water line to catch any excess water. With an adjustable wrench, turn off and disconnect cold water line from the supply line at the shut-off valve. Attach threaded ends of dual port adapter to shut-off valve and reattach cold water line to the dual port adapter.

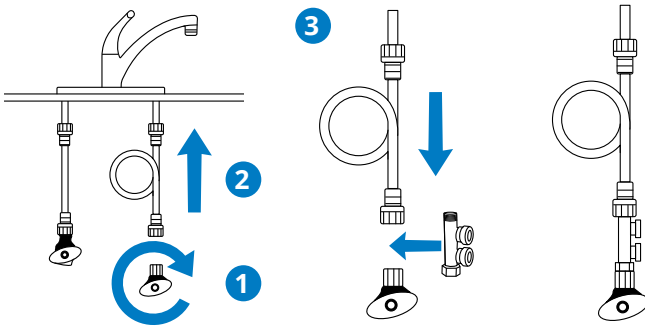

NOTE: Do not over tighten dual port adapter as this may result in a restriction of water flow.

- B. Connect 3/8" tubing to the bottom port of the dual port adapter. Run the opposite end of the tubing to the left side of the system head (marked "IN"), cut to length, and push tubing into the inlet until it stops.
- C. Using the second piece of 3/8" tubing, connect one end to the top port of the dual port adapter. Run the opposite end of the tubing to the right side of the system head (marked "OUT") cut to length, and push tubing into the outlet until it stops.

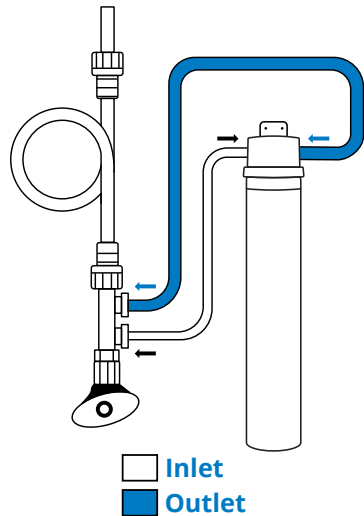

NOTE: Use 3/8" quick connect elbows in each port on the system head if necessary.

4 Flush System and Check for Leaks

- A. Turn on cold water to the kitchen faucet.
- B. With the faucet on, slowly open the cold water shut-off valve.
- C. Leave water running to flush system for 15 minutes to remove carbon fines. While the system is flushing, check for leaks. Once the system is flushed, turn off kitchen faucet.

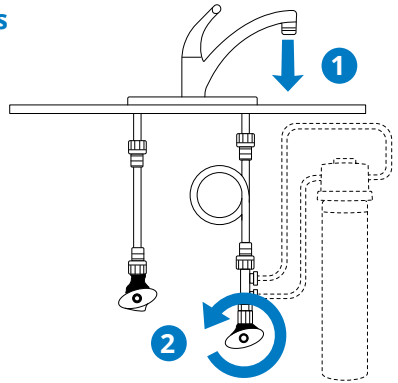

NOTE: Do not drink flushed water.

FILTER REPLACEMENT

- A. Turn off COLD water supply under the sink.
- B. Remove the old filter from the system head. Rotate the filter to the left until it unlocks, pull down and discard.
- C. To attach new filter to the system, align all connection points, push in, and turn filter to the right until it locks.
- D. Once filter is locked into place, turn on the COLD water supply to pressurize the system. Check for leaks.
- E. Turn on kitchen faucet to COLD water and run water through the system for 15 minutes. Once the system is flushed, turn off kitchen faucet.

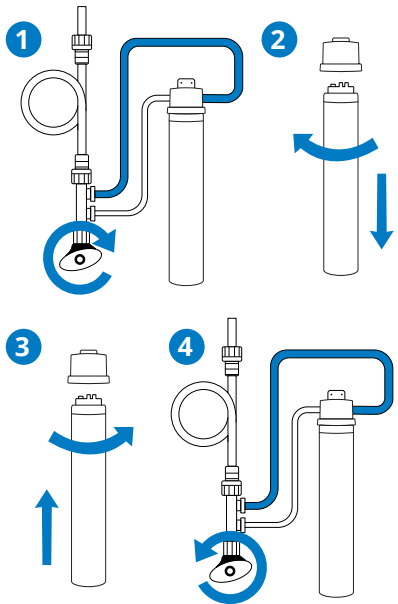

NOTE: Do not drink flushed water.

Model	Replacement	Rated Capacity
AQ-MF-1	AQ-MF-1-R	784 gallons 2,967 liters
Operating Temp. Range	Operating Pressure Range	Rated Flow
35 - 100° F 1.66 - 37.78° C	10 - 125 psi 68.95 - 861.8 kPa	1.5 gpm 5.67 lpm
Manufactured by: Aquasana, Inc. 6310 Midway Road · Haltom City, Texas 76117 866-662-6885		



System certified by IAPMO R&T against NSF/ANSI Standards 42, 53, and 401 for the reduction of the claims specified on the Performance Data Sheet and at www.IAPMO.org.

For a full list contaminants filtered, scan to view the AQ-MF-1 Performance Data Sheet on Aquasana.com.





Claryum® Direct Connect 1-Year Limited Warranty

WHO IS COVERED

AQUASANA AND ITS SUPPLIERS, (herein collectively referred to as “Manufacturer”) warrants to the original owner who purchased and installed the system (hereinafter “Owner”). Registration of the product is not required to receive warranty coverage as specified in this document. If you purchased from an Aquasana-authorized reseller or dealer, proof of purchase is required.

WHAT IS COVERED

This Warranty covers defects in materials or workmanship during the Limited Warranty period of your Aquasana Water Filtration System including sub-components purchased with original system (may or may not include faucet and fittings), except as provided below. The water filter is warranted only when it is installed, operated and maintained in accordance with the instructions accompanying the water filter found on Aquasana.com. A water filter should be installed in such a manner that, if the system or any connection thereto should leak, the resulting flow of water will not cause damage to the area in which it is installed. For detailed instructions read the manual accompanying the water filter and review drawings in the manual.

FOR HOW LONG

This Warranty runs for 12 months (365 days) from the date of purchase by a consumer (hereinafter “Warranty Period”). No Warranty coverage will be provided if the claimant is unable to provide proof of purchase from an authorized Aquasana reseller. Estimated lifespan of products is for information only and is based on usage approximations. Water conditions and use rates may limit the functional lifespan of your filter. This Limited Warranty does not extend to the full estimated life span of the system.

WHAT AQUASANA WILL DO

1. If necessary, the Manufacturer will provide a replacement that fulfills the remaining estimated lifespan/capacity of your original purchase and send it to you with installation instructions. If industry standards, product improvements or product obsolescence prohibit Manufacturer from furnishing an identical model replacement water filter under this Warranty, the Owner will be furnished with a new water filter of comparable remaining capacity and functionality; however, the Owner will be charged for the additional value of the item(s) which Manufacturer has incorporated in the replacement water filter. The Warranty period for any replacement will run for the balance of the original 365 days.
2. Component Part – If any component part proves to Manufacturer’s satisfaction to be defective in material or workmanship within the Warranty period listed on the data plate label, the Manufacturer will furnish the Owner with a replacement for the defective part(s).
3. Return of Defective Water Filter and Component Parts – Manufacturer reserves the right to examine the alleged defect in the water filter or component part(s), and it will be the Owner’s obligation to return the water filter and/or component part(s) to the Manufacturer at the Manufacturers request.
 - a. When returning a water filter, it must include all component parts.
 - b. When returning component part(s), they must be individually tagged and identified with the water filter’s model number, date of purchase, and date of installation.

WHAT IS NOT COVERED

1. This Warranty does not cover systems or components that were not installed in compliance with the instructions or that have been abused or operated incorrectly.
2. This Warranty does not provide routine replacement filter cartridges which must be purchased separately and replaced as indicated; replacement filter cartridges are available only when the original cartridge supplied with the system is damaged or defective when purchased. This Warranty applies only to products purchased from Aquasana or an Aquasana-authorized reseller or dealer.
3. Except when specifically prohibited by the applicable state law, the Limited Warranty stated herein is in lieu of any and all warranties, express or implied (whether written or oral), including, but not limited to, the implied warranties of merchantability and fitness for a particular purpose.
4. Except when specifically prohibited by the applicable state law, the Manufacturer shall not be liable for any incidental, consequential, special, or contingent damages or expenses,

arising, directly or indirectly, from any defect in the water filter of the use of the water filter.

5. Manufacturer shall not be liable for any incidental, consequential, special, punitive, or contingent damages or expenses, arising, directly or indirectly, from any defect in the water filter or the use of the water filter, including but not limited to water damage.
6. Manufacturer shall not be liable for any water damage arising, directly or indirectly, from any defect in the water filter or component part(s) or from its use.
7. Manufacturer shall not be liable for any damage or product failures caused by any of the following:
 - The water filter or any of its component parts have been subject to misuse, alteration, neglect or accident.
 - The water filter has not been installed in accordance with the applicable local plumbing and/or building code(s) and/or regulations or in their absence.
 - The water filter is not installed, operated and maintained in accordance with the printed Manufacturer’s instructions, including if the water filter has any additional aftermarket equipment introduced into the sealed system not approved by the manufacturer.
 - The water filter is exposed to highly corrosive conditions.
 - The water filter is not continuously supplied with potable water.
 - The water filter is not operated within the factory calibrated temperature limits.
 - The water filter is installed in direct sunlight or exposed to freezing temperatures.
 - The water filter or any of its component parts fail due to sediment build-up.
 - Clogging due to purchaser’s failure to replace the filter cartridges.
 - Damage caused by fire, flood or acts of God.
 - Damage caused by over-pressurization in the water line.
8. Manufacturer shall not be liable for any claims related to excessive noise, smell, or taste of water.
9. This Warranty does not cover damage caused by the use of parts that are not genuine Aquasana parts. This includes, but is not limited to replacement filters, faucets, and/or diverter valves.
10. Except when specifically prohibited by the applicable state law, the Owner, and not the Manufacturer, shall be liable for and shall pay for all charges for labor or other expenses incurred in the removal, repair or replacement of the water filter or any component part(s) claimed to be defective or any expense incurred to remedy any defect in the product. Such charges may include, but are not necessarily limited to:
 - a. All freight, shipping, handling and delivery costs of forwarding a new water filter or replacement part(s) to the owner.
 - b. All costs necessary or incidental in removing the defective water filter or component part(s) and installing a new water filter or component part(s).
 - c. Any material required to complete, and/or permits required for, installation of a new water filter or replacement part(s), and
 - d. All costs necessary or incidental in returning the defective water filter or component part(s) to a location designated by the Manufacturer.
11. This warranty provides specific legal rights and limitations, but you may have other rights under applicable state law.

HOW TO GET SERVICE

To receive service under this Warranty, you must contact Aquasana (A. O. Smith Water Treatment (North America), Inc.) at 1-866-662-6885 or support@aquasana.com within the Warranty Period to describe the problem to a customer service representative who will verify that the product is under Warranty and determine whether a part or the system will be replaced and whether you must send back the unit. You will be required to provide both proof of purchase and proper installation.

HOW STATE LAW APPLIES

This Warranty gives you specific rights and you may have other rights which vary from state to state. Some states do not allow the exclusion or limitation of incidental or consequential damages, so the above limitation or exclusion may not apply to you.



water for life®

Protect your investment and save money with Water for Life®.

Our Water for Life® program helps you protect the investment you've made in your family's health with an extended limited warranty on your new filtration system, a 15% discount on replacement filters, and free shipping.



Extended Limited Warranty

Our performance promise to you – free replacement parts when needed.*



Discounted Replacements

The only way to lock in a 15% discount on replacement filters.



Free Shipping

Replacements shipped to you right when you need them – at no extra cost.



No Contract

Free to join and cancel anytime – no long-term commitment required.

CONTACT US TO LEARN MORE



866-275-2319



waterforlife@aquasana.com

*Exclusions apply. Limited Warranty details are available at aquasana.com. Benefits are for the term of Water for Life membership.



LOVE IT?

Please let us know with a review on Aquasana or your retailer's site.



NEED HELP?

Give us a call at **866-662-6885** and tell us what's going on.

Aquasana, Inc.
6310 Midway Road
Haltom City, Texas 76117
866.662.6885 USA
877.332.7873 Canada
www.aquasana.com

100329589

AQ-MF-1_OM_08112025

