



U80 Model UnderCounter Ice Machines

Installation, Use & Care Manual

This manual is updated as new information and models are released.
Visit our website for the latest manual. www.manitowocice.com

America's #1 Selling Ice Machine
Part Number 040006020 08/22



Safety Notices

Safety Notices

Read these precautions to prevent personal injury:

- Read this manual thoroughly before operating, installing or performing maintenance on the equipment. Failure to follow instructions in this manual can cause property damage, injury or death.
- Routine adjustments and maintenance procedures outlined in this manual are not covered by the warranty.
- Proper installation, care and maintenance are essential for maximum performance and trouble-free operation of your equipment. Visit our website www.manitowocice.com for manual updates, translations, or contact information for service agents in your area.
- This equipment contains high voltage electricity and refrigerant charge. Installation and repairs are to be performed by properly trained technicians aware of the dangers of dealing with high voltage electricity and refrigerant under pressure. The technician must also be certified in proper refrigerant handling and servicing procedures. All lockout and tag out procedures must be followed when working on this equipment.
- This equipment is intended for indoor use only. Do not install or operate this equipment in outdoor areas.

DEFINITIONS

DANGER

Indicates a hazardous situation that, if not avoided, will result in death or serious injury. This applies to the most extreme situations.

Warning

Indicates a hazardous situation that, if not avoided, could result in death or serious injury.

Caution

Indicates a hazardous situation that, if not avoided, could result in minor or moderate injury.

Notice

Indicates information considered important, but not hazard-related (e.g. messages relating to property damage).

NOTE: Indicates useful, extra information about the procedure you are performing.

 **Warning**

Follow these precautions to prevent personal injury during installation of this equipment:

- Installation must comply with all applicable equipment fire and health codes with the authority having jurisdiction.
- To avoid instability the installation area must be capable of supporting the combined weight of the equipment and product. Additionally the equipment must be level side to side and front to back.
- Ice machines require a deflector when installed on an ice storage bin. Prior to using a non-OEM ice storage system with this ice machine, contact the bin manufacture to assure their ice deflector is compatible.
- Prior to installing a non-OEM ice storage system with this ice machine, follow the manufacturers installation procedures and verify the location and installation meets the local/national mechanical codes and stability requirements.
- Remove all removable panels before lifting and installing and use appropriate safety equipment during installation and servicing, Two or more people are required to lift or move this appliance to prevent tipping and/ or injury.
- Connect to a potable water supply only.
- Do not damage the refrigeration circuit when installing, maintaining or servicing the unit.
- This equipment contains refrigerant charge. Installation of the line sets must be performed by a properly trained and EPA certified refrigeration technician aware of the dangers of dealing with refrigerant charge equipment.
- Legs or casters must be installed and the legs/ casters must be screwed in completely. When casters are installed the mass of this unit will allow it to move uncontrolled on an inclined surface. These units must be tethered/secured to comply with all applicable codes. Swivel casters must be mounted on the front and rigid casters must be mounted on the rear. Lock the front casters after installation is complete.

 **DANGER**

Do not operate equipment that has been misused, abused, neglected, damaged, or altered/modified from that of original manufactured specifications. This appliance is not intended for use by persons (including children) with reduced physical, sensory or mental capabilities, or lack of experience and knowledge, unless they have been given supervision concerning use of the appliance by a person responsible for their safety. Do not allow children to play with, clean or maintain this appliance without proper supervision.

 **Warning**

Follow these precautions to prevent personal injury while operating or maintaining this equipment:

- Read this manual thoroughly before operating, installing or performing maintenance on the equipment, Failure to follow instructions in this manual can cause property damage, injury or death.
- Crush/Pinch Hazard.Keep hands clear of moving components. Components can move without warning unless power is disconnected and all potential energy is removed.
- Moisture collecting on the floor will create a slippery surface.Clean up any water on the floor immediately to prevent a slip hazard.
- Objects placed or dropped in the bin can affect human health and safety. Locate and remove any objects immediately.
- Never use sharp objects or tools to remove ice or frost. Do not use mechanical devices or other means to accelerate the defrosting process.
- When using cleaning fluids or chemicals, rubber gloves and eye protection (and/or face shield) must be worn.
- Keep ventilation openings, in the appliance enclosure or in the built-in structure, clear of obstruction.

DANGER

Follow these flammable refrigeration system requirements during installation, use or repair of this equipment.

- Refer to nameplate-Ice machine models may contains up to 150 grams of R290(propane) refrigerant. R290(propane) is flammable in concentrations of air between approximately 2.1% and 9.5%by volume (LEL lower explosion limit and UEL upper explosion limit). An ignition source an a temperature higher than 470 °C is needed for a combustion to occur. Refer to nameplate to identify the type of refrigerant in your equipment. Only trained and qualified personnel aware of the dangers are allowed to work on the equipment.
- To minimize the risk of ignition due to improper installation, replacement parts or service procedures, only refrigeration technicians with flammable refrigerant training who are aware of the dangers of dealing with high voltage electricity and refrigerant under pressure are allowed to work on this equipment.
- All replacement parts must be like components obtained from the equipment manufactures authorized replacement part network.
- This equipment must be installed in accordance with the ASHRAE 15 Safety Standard for Refrigeration Systems. This equipment can not be installed in corridors or hallways of public buildings.
- This equipment can not be installed in corridors or hallways of public buildings.
- Installation must comply with all applicable equipment fire and health codes with the authority having jurisdiction.
- All lockout and tag out procedures must be followed when working on this equipment.
- This equipment contains high voltage electricity and refrigerant charge. Shoring electrical wires to refrigeration tubing may result in an explosion, All electrical power must be disconnected from the system before servicing the system. Refrigerant leaks, can result in serious injury or death from explosion, fire, or contact with refrigerant or lubricant mists.
- Do not damage the refrigeration circuit when installing, maintaining or servicing the unit. Never use sharp objects or tools to remove ice or frost. Do not use mechanical devices or other means to accelerate the defrosting process.

DANGER

Follow these precautions to prevent personal injury during use and maintenance of this equipment:

- It is the responsibility of the equipment owner to perform a Protective Equipment Hazard Assessment to ensure adequate protection during maintenance procedures.
- Do Not Store Or Use Gasoline Or Other Flammable Vapors Or Liquids In The Vicinity Of This Or Any Other Appliance. Never use flammable oil soaked cloths or combustibile cleaning solutions for cleaning.
- All covers and access panels must be in place and properly secured when operating this equipment.
- Risk of fire/shock, All minimum clearances must be maintained. Do not obstruct vents or openings.
- Failure to disconnect power at the main power supply disconnect could result in serious injury or death. The power switch DOES NOT disconnect all incoming power.
- All utility connections and fixtures must be maintained in accordance with the authority having jurisdiction.
- Turn off and lockout all utilities (electric, water) according to approved practices during maintenance or servicing.
- Units with tow power cords must be plugged into individual branch circuits. During movement, cleaning or repair it is necessary to unplug both power cords.
- Never use a high-pressure water jet for cleaning on the interior or exterior of this unit. Do not use power cleaning equipment, steel wool, scrapers or wire brushes on stainless steel or painted surfaces.
- Two or more people are required to move this equipment to prevent tipping.
- Locking the front casters after moving is the owner's responsibility. When casters are installed, the mass of this unit will allow it to move uncontrolled on an inclined surface. These units must be tethered/ secured to comply with all applicable codes.
- The on-site supervisor is responsible for ensuring that operators are made aware of the inherent dangers of operating this equipment.
- Do not operate any appliance with a damaged cord or plug. All repairs must be performed by a qualified service company.

THIS PAGE INTENTIONALLY LEFT BLANK



Table of Contents

Section 1

General Information

Model Numbers	3
Accessories	3
Tri-liminator Water Filter System	3
Manitowoc De-scaler and Sanitizer	3

Section 2

Installation Instructions

Location of Ice Machine	5
Ice Machine Heat of Rejection	5
Leveling the Ice Machine	5
Electrical Service	6
Voltage	6
Fuse/Circuit Breaker	6
Electrical Rating	6
Water Service/Drains	6
Water Supply	6
Drain Connections	6
Water Supply and Drain Line Sizing/Connections	7
Installation Checklist	8
Before Starting the Ice Machine	8
Ice Machine Inspection	8

Section 3

Operation

Ice Making Sequence of Operation	9
Initial Start-up Or Start-up After Automatic Shut-off	9
Freeze Sequence	9
Harvest Sequence	9
Automatic Shut-off	9
Operational Checks	10
General	10
Siphon System	10
Water Float Valve Check	10
Water Level Check	11
Ice Bridge Thickness Check	11

Section 4

Maintenance

Interior De-scaling and Sanitizing	13
General	13
De-scaling and Sanitizing Procedure	13
Exterior Cleaning	18
Cleaning the Condenser	19
Removal from Service/Winterization	19

Section 5

Customer Support

Checklist	21
------------------------	-----------

Table of Contents (continued)

Safety Limit Feature	22
Commercial Ice Machine Warranty	23
Residential Ice Machine Limited Warranty	24



Section 1

General Information

Model Numbers

This manual covers the following models:

UDE0080A	115/60/1
UDE0080A	230/50/1
UDP0080A	230/50/1
UDE0080A	230/60/1

Accessories

Contact your Manitowoc distributor for these optional accessories:

TRI-LIMINATOR WATER FILTER SYSTEM

Engineered specifically for Manitowoc ice machines, Tri-Liminator water filters are an efficient, dependable, and affordable method of inhibiting scale formation, filtering sediment, and removing chlorine taste and odor.

MANITOWOC DE-SCALER AND SANITIZER

Manitowoc Ice Machine De-scaler and Sanitizer are available in convenient 16 oz. (473 ml) and 1 gal (3.78 l) bottles. These are the only de-scaler and sanitizer approved for use with Manitowoc products.

De-scaler Part Number		Sanitizer Part number	
16oz	94-0456-3	16oz	94-0565-3
1 Gallon	94-0580-3	1 Gallon	94-0581-3

THIS PAGE INTENTIONALLY LEFT BLANK



Section 2

Installation Instructions

Location of Ice Machine

The location selected for the ice machine must meet the following criteria. If any of these criteria are not met, select another location.

- The location must be indoors.
- The location must be free of airborne and other contaminants.
- The air temperature must be at least 2°C (35°F), but must not exceed 43°C (110°F).
- The location must not be near heat-generating equipment or in direct sunlight.
- The location must be capable of supporting the weight of the ice machine and a full bin of ice.
- The location must allow enough clearance for water, drain and electrical connections in the **rear of the ice machine**.
- The location must not obstruct airflow through or around the ice machine (condenser airflow is in and out the front). Refer to the chart below for clearance requirements.

	Self-Contained Air-Cooled
Top/Sides	5" (127 mm)*
Back	5" (127 mm)*

NOTE: The ice machine may be built into a cabinet.

* There is no minimum clearance requirement for the top or left and right sides of the ice machine. The listed values are recommended for efficient operation and servicing only.

⚠ Caution

The ice machine must be protected if it will be subjected to temperatures below 32°F (0°C). Failure caused by exposure to freezing temperatures is not covered by the warranty. See "Removal from Service/Winterization" Section 4.

Ice Machine Heat of Rejection

Series Ice Machine	Heat of Rejection*	
	Air Conditioning**	Peak
UDE(P)0080A	2050	2500

* B.T.U./Hour

** Because the heat of rejection varies during the ice making cycle, the figure shown is an average.

Ice machines, like other refrigeration equipment, reject heat through the condenser. It is helpful to know the amount of heat rejected by the ice machine when sizing air conditioning equipment where self-contained air-cooled ice machines are installed.

Leveling the Ice Machine

After moving the ice machine into the installation location, it must be leveled for proper operation. Follow these steps to level the ice machine:

1. Check the level of the ice machine from front to back and from side to side.
2. If the ice machine is not level, adjust the leveling glides on each corner of the base of the ice machine as necessary.

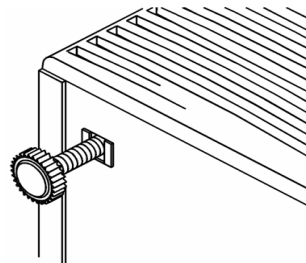

Leveling Glide

3. Check the level of the ice machine after each adjustment of the leveling glides.
4. Repeat steps 2 and 3 until the ice machine is level from front to back and from side to side.

Electrical Service

Warning

All wiring must conform to local, state and national codes.

Voltage Phase	Total Amps
230/50/1	2.6
230/60/1	3.1
115/60/1	5.2

VOLTAGE

The maximum allowable voltage variation is ± 10% of the rated voltage on the ice machine model/serial number plate at start-up (when the electrical load is highest).

Warning

The ice machine must be grounded in accordance with national and local electrical codes.

Warning

Never use an extension cord. If an outlet is not within reach of the ice machine's power cord, have a proper amperage outlet wired closer to the ice machine.

FUSE/CIRCUIT BREAKER

A separate fuse/circuit breaker must be provided for each ice machine.

NOTE: A disconnect means must be provided for field wiring.

ELECTRICAL RATING

The electrical rating is used to help select the wire size of the electrical supply. The wire size (or gauge) also depends on location, materials used, length of run, etc., so it must be determined by a qualified electrician.

Water Service/Drains

WATER SUPPLY

Local water conditions may require treatment of the water to inhibit scale formation, filter sediment, remove chlorine, and improve taste and clarity.

Important

If you are installing a Manitowoc Tri-Liminator water filter system, refer to the Installation Instructions supplied with the filter system for ice making water inlet connections.

Follow these guidelines to install water inlet lines:

- Connect to potable water supply only.
- Do not connect the ice machine to a hot water supply. Be sure all hot water restrictors installed for other equipment are working. (Check valves on sink faucets, dishwashers, etc.)
- If water pressure exceeds the maximum recommended pressure, obtain a water pressure regulator from your Manitowoc distributor.
- Install a water shut-off valve for both the ice making and condenser water lines (if applicable).
- Insulate water lines to prevent condensation.

Important

The water inlet line is connected to the water valve. This valve is located just behind the front panel of the ice machine.

DRAIN CONNECTIONS

Follow these guidelines when installing drain lines to prevent drain water from flowing back into the ice machine and storage bin:

- Drain lines must have a 2.5 cm drop per 1 meter of run (1.5 inch per 5 feet), and must not create traps.
- The floor drain must be large enough to accommodate drainage from all drains.
- Insulate the bin drain line to prevent condensation.



WATER SUPPLY AND DRAIN LINE SIZING/CONNECTIONS

⚠ Caution
Plumbing must conform to state and local codes.

	Water Temperature	Water Pressure	Ice Machine Fitting	Tubing Size Up to Ice Machine Fitting
Ice Making Water Inlet	0.6°C (33°F) Min. ¹ 32.2°C (90°F) Max. ²	137.9 kPA (20 psi) Min. ¹ 551.5 kPA (80 psi) Max. ²	3/8" male hose connection	0.95 cm (3/8") minimum inside diameter
Ice Making/Bin Water Drain	—	—	1.59 cm (5/8") inside diameter flexible hose	1.59 cm (5/8") minimum inside diameter

¹ Min. = Minimum
² Max. = Maximum

INSTALLATION NOTE(SWITZERLAND)

The connection to the drinking water network must be made with a certified backflow preventer type EA(EN13959) and with a certified connection hose (EN13618 or En61770) on site.

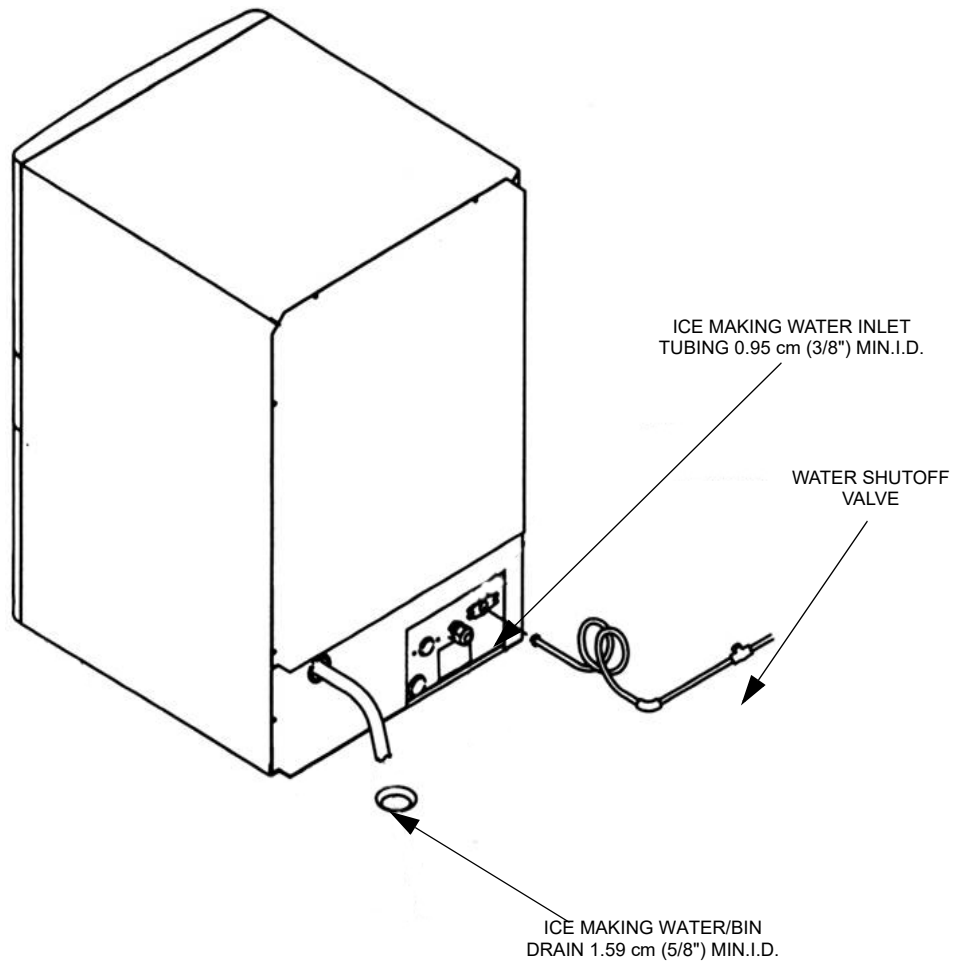

Typical Water Supply and Drain Line Sizing and Connections



Installation Checklist

- Is the ice machine level?
- Has all of the internal packing been removed?
- Have all of the electrical and water connections been made?
- Has the supply voltage been tested and checked against the rating on the nameplate?
- Is there proper clearance around the ice machine for air circulation?
- Has the ice machine been installed where ambient temperatures will remain in the range of 35° – 110°F (2° – 43°C)?
- Has the ice machine been installed where the incoming water temperature will remain in the range of 33° – 90°F (1° – 32°C)?
- Are all electrical leads free from contact with refrigeration lines and moving equipment?
- Has the owner/operator been instructed regarding maintenance and the use of Manitowoc De-scaler and Sanitizer?
- Has the owner/operator completed the warranty registration card?
- Has the ice machine and bin been sanitized?
- Has this manual been given to the owner/operator?

Before Starting the Ice Machine

All Manitowoc ice machines are factory-operated and adjusted before shipment. Normally, new installations do not require any adjustment.

To ensure proper operation, follow the Operational Checks. Starting the ice machine and completing the Operational Checks are the responsibilities of the owner/operator.

Adjustments and maintenance procedures outlined in this manual are not covered by the warranty.

Ice Machine Inspection

Check all water fittings and lines for leaks. Also, make sure the refrigeration tubing is not rubbing or vibrating against other tubing, panels, etc.

Do not put anything (boxes, etc.) in front of the ice machine. There must be adequate airflow through and around the ice machine to maximize ice production and ensure long component life.

 Warning PERSONAL INJURY POTENTIAL Do not operate equipment that has been misused, abused, neglected, damaged, or altered/modified from that of original manufactured specifications.
--



Section 3

Operation

Ice Making Sequence of Operation

INITIAL START-UP OR START-UP AFTER AUTOMATIC SHUT-OFF

1. Pressure Equalization

Before the compressor starts the hot gas valve is energized for 15 seconds to equalize pressures during the initial refrigeration system start-up.

2. Refrigeration System Start-Up

The compressor starts after the 15-second pressure equalization, and remains on throughout the entire Freeze and Harvest Sequences. The hot gas valve remains on for 5 seconds during initial compressor start-up and then shuts off.

At the same time the compressor starts, the condenser fan motor (air-cooled models) is supplied with power throughout the entire Freeze and Harvest Sequences. The fan motor is wired through a fan cycle pressure control, therefore it may cycle on and off. (The compressor and condenser fan motor are wired through the relay. As a result, any time the relay coil is energized, the compressor and fan motor are supplied with power.)

FREEZE SEQUENCE

3. Prechill

The compressor is on for 30 seconds prior to water flow to Prechill the evaporator.

4. Freeze

The water pump starts after the 30-second Prechill. An even flow of water is directed across the evaporator and into each cube cell, where it freezes.

When sufficient ice has formed, the water flow (not the ice) contacts the ice thickness probe. After approximately 7 seconds of continual water contact, the Harvest Sequence is initiated. The ice machine cannot initiate a Harvest Sequence until a 6-minute freeze time has been surpassed.

HARVEST SEQUENCE

5. Harvest

The water pump de-energizes stopping flow over the evaporator. The rising level of water in the sump trough diverts water out of the overflow tube, purging excess minerals from the sump trough. The hot gas valve also opens to divert hot refrigerant gas into the evaporator.

The refrigerant gas warms the evaporator causing the cubes to slide, as a sheet, off the evaporator and into the storage bin. The sliding sheet of cubes contacts the ice damper, opening the bin switch.

The momentary opening and re-closing of the bin switch terminates the Harvest Sequence and returns the ice machine to the Freeze Sequence (steps 3 - 4).

AUTOMATIC SHUT-OFF

6. Automatic Shut-Off

When the storage bin is full at the end of a Harvest Sequence, the sheet of cubes fails to clear the ice damper and will hold it down. After the ice damper is held open for 7 seconds, the ice machine shuts off. The ice machine remains off for 3 minutes before it can automatically restart.

The ice machine remains off until enough ice has been removed from the storage bin to allow the ice to fall clear of the damper. As the ice damper swings back to the operating position, the bin switch re-closes and the ice machine restarts (steps 1 - 2), provided the 3-minute delay period is complete.

Operational Checks

GENERAL

Your Manitowoc ice machine was factory-operated and adjusted before shipment. Normally, a newly installed ice machine does not require any adjustment.

To ensure proper operation, always follow these Operational Checks when starting the ice machine:

- for the first time
- after a prolonged out of service period
- after de-scaling and sanitizing

Routine adjustments and maintenance procedures outlined in this manual are not covered by the warranty.

SIPHON SYSTEM

To reduce mineral build-up and cleaning frequency, the water in the sump trough must be purged during each harvest cycle.

When the water pump de-energizes the level in the water trough rises above the standpipe starting a siphon action. The siphon action stops when the water level in the sump trough drops. When the siphon action stops, the float valve refills the water trough to the correct level.

Siphon System Check

Follow steps 1 through 6 under water level check.

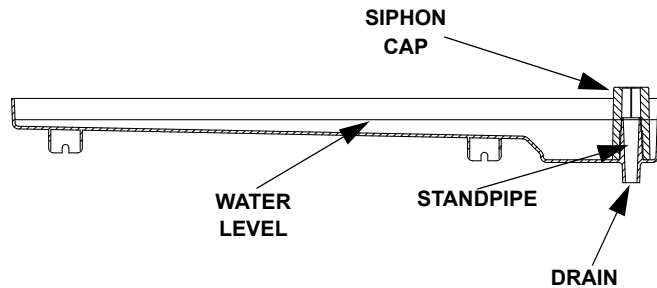

WATER FLOAT VALVE CHECK

Before water will flow into the water trough the float valve shut-off must be in the OPEN position.

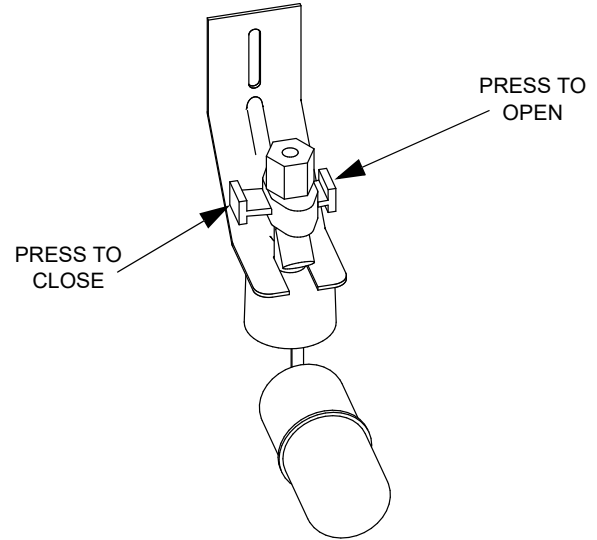

WATER LEVEL CHECK

Check the water level while the ice machine is in the ice mode and the water pump is running. The correct water level is 1/4" (6.3 mm) to 3/8" (9.5 mm) below the top of the standpipe a line in the water trough indicates the correct level.

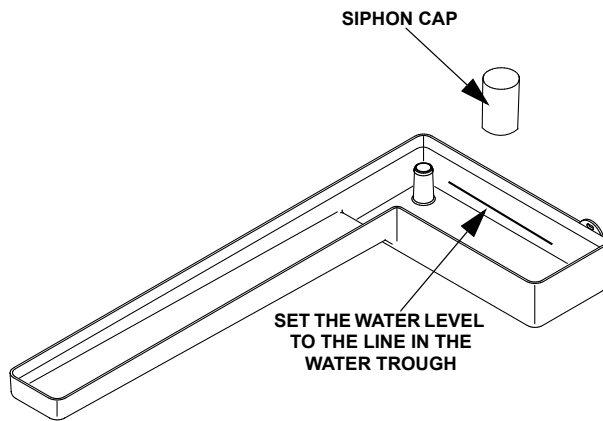

The float valve is factory-set for the proper water level. If adjustments are necessary:

1. Verify the ice machine is level (see page 3-6).
2. Remove the siphon cap from the standpipe.
3. Place the main ON/OFF/WASH toggle switch to the ON position, and wait until the float valve stops adding water.
4. Adjust the water level to (1/4" to 3/8" [6.3 to 9.5 mm] below the standpipe) the line in the water trough.
5. Loosen the two screws on the float valve bracket.
6. Raise or lower the float valve assembly as necessary, then tighten the screws.
7. Move the main ON/OFF/ WASH toggle switch to the OFF position. The water level in the trough will rise above the standpipe and run down the drain.
8. Replace the siphon cap on the standpipe, and verify water level and siphon action by repeating steps 3 through 5.

ICE BRIDGE THICKNESS CHECK

NOTE: During shipping and installation the ice thickness probe may shift, requiring further adjustment to achieve the rated energy efficiency and production. The ice weight per cycle must be within the minimum and maximum for your ice machine series. Capture and weigh the ice from the second freeze/harvest cycle. The target weight is the middle of the minimum and maximum weight in the chart below.

Series Ice Machine	Ice Weight From One Cycle	
	Minimum Ice Weight	Maximum Ice Weight
UDE(P)0080A	1.1 lbs	1.3 lbs
Target weight is the middle of the minimum and maximum weight.		

The ice thickness probe is factory-set to maintain the ice bridge thickness at 1/8" (3.2 mm).

1. Inspect the bridge connecting the cubes. It should be about 1/8" (3.2 mm) thick.
2. If adjustment is necessary, turn the ice thickness probe adjustment screw clockwise to increase bridge thickness, or counterclockwise to decrease bridge thickness.

NOTE: Turning the adjustment 1/3 of a turn will change the ice thickness about 1/16" (1.5 mm).

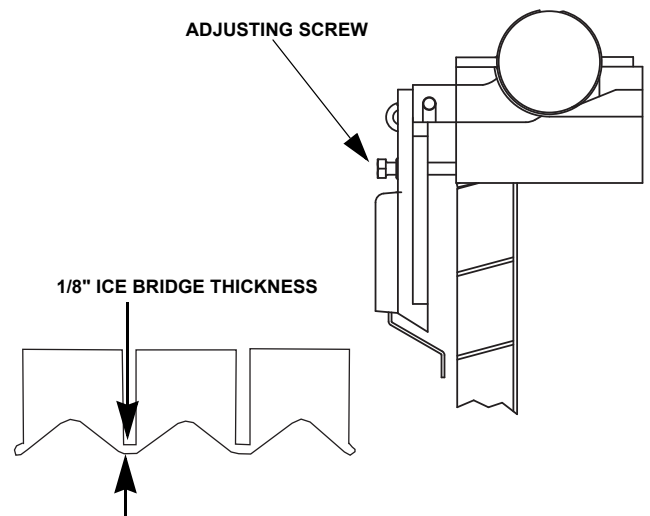

Make sure the ice thickness probe wire and the bracket do not restrict movement of the probe.

THIS PAGE INTENTIONALLY LEFT BLANK



Section 4

Maintenance

Interior De-scaling and Sanitizing

GENERAL

De-scale and sanitize the ice machine every six months for efficient operation. If the ice machine requires more frequent de-scaling, consult a qualified service company to test the water quality and recommend appropriate water treatment. Sanitizing can be performed independently and more frequently than de-scaling if desired.

The ice machine must be taken apart for de-scaling and sanitizing.

Caution

Use only Manitowoc approved Ice Machine De-scaler (part number 94-0546-3) and Sanitizer (part number 94-0565-3). It is a violation of Federal law to use these solutions in a manner inconsistent with their labeling. Read and understand all labels printed on bottles before use.

DE-SCALING AND SANITIZING PROCEDURE

Caution

Do not mix Ice Machine De-scaler and Sanitizer solutions together. It is a violation of Federal law to use these solutions in a manner inconsistent with their labeling.

Warning

Wear rubber gloves and safety goggles (and/or face shield) when handling Ice Machine De-scaler or Sanitizer.

Ice machine de-scaler is used to remove lime scale and mineral deposits. Ice machine sanitizer disinfects and removes algae and slime.

Step 1 Set the toggle switch to the OFF position after ice falls from the evaporator at the end of a Harvest cycle. Or, set the switch to the OFF position and allow the ice to melt off the evaporator.

Caution

Never use anything to force ice from the evaporator. Damage may result.

Step 2 Remove all ice from the bin.

Step 3 To start a cleaning cycle, move the toggle switch to the WASH position.

Step 4 Add the proper amount of Manitowoc Ice Machine De-scaler to the water trough.

Model	Amount of De-scaler
UDE(P)0080A	1.5 ounces (45 ml)

Step 5 Wait until the clean cycle is complete (approximately 22 minutes) then place the toggle switch in the OFF position, disconnect power and water supplies to the ice machine.

Warning

Disconnect electric power to the ice machine at the electric switch box before proceeding.

Step 6 Remove parts for de-scaling.

A. Remove Two Thumbscrews and Water Pump Cover (When Used).

B. Remove the Vinyl Hose Connecting the Water Pump and Water Distribution Tube

C. Remove Water Pump

- Disconnect the water pump power cord
- Loosen the screws securing the pump-mounting bracket to the bulkhead
- Lift the pump and bracket assembly off the mounting screws..

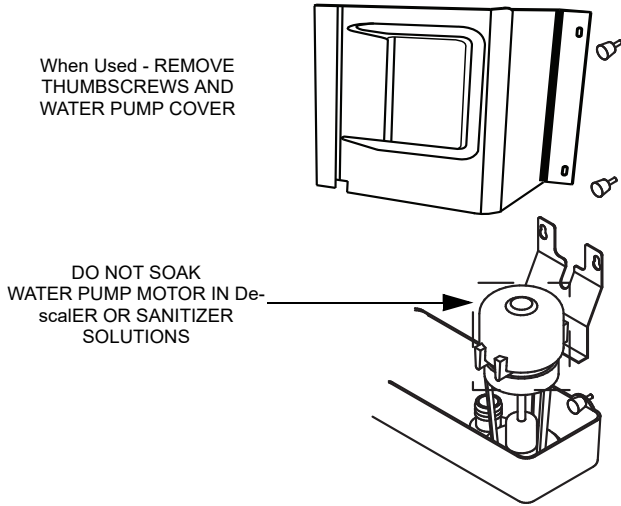

Water Pump Removal

D. Remove the Ice Thickness Probe

- Compress the side of the ice thickness probe near the top hinge pin and remove it from the bracket.

NOTE: At this point, the ice thickness probe can easily be cleaned. If complete removal is desired follow the ice thickness probe wire to the bulkhead grommet (exit point) in the back wall. Pop the bulkhead grommet out of the back wall by inserting fingernails or a flat object between the back wall and the grommet and prying forward. Pull the bulkhead grommet and wire forward until the connector is accessible, then disconnect the wire lead from the connector.

Ice Thickness Probe Cleaning

- Mix a solution of Manitowoc ice machine de-scaler and water (2 ounces of de-scaler to 16 ounces of water) in a container.
- Soak the ice thickness probe a minimum of 10 minutes.

Clean all ice thickness probe surfaces and verify the ice thickness probe cavity is clean. Rinse thoroughly with clean water, then dry completely. Incomplete rinsing and drying of the ice thickness probe can cause premature harvest.

E. Remove the Water Distribution Tube

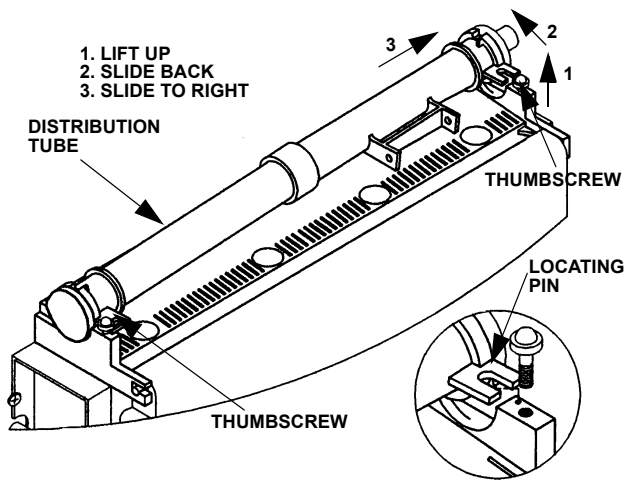

- Loosen the two thumbscrews, which secure the distribution tube.
- Lift the right side of the distribution tube up off the locating pin, then slide it back and to the right.

⚠ Caution
Do not force this removal. Be sure the locating pin is clear of the hole before sliding the distribution tube out.



Disassembly

- Twist both of the inner tube ends until the tabs line up with the keyways.
- Pull the inner tube ends outward.

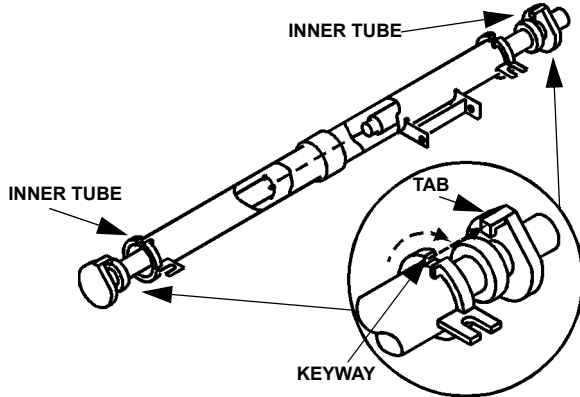
**F. Remove the Float Valve**

- Turn the splash shield counterclockwise one or two turns.

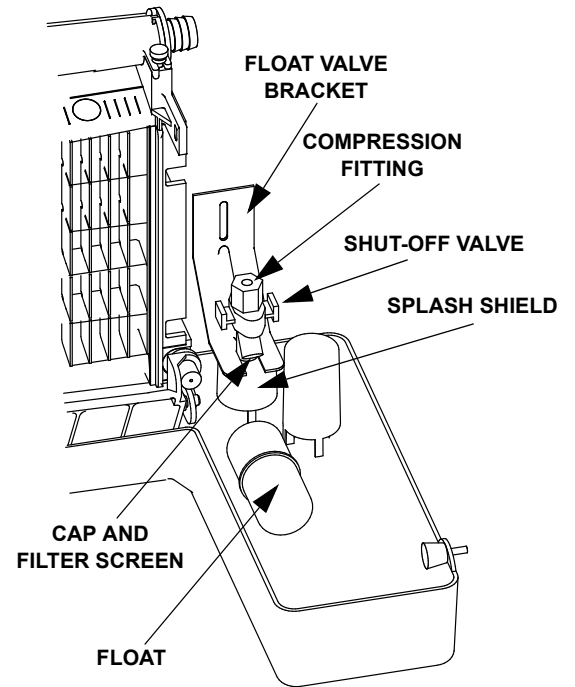

- Pull the float valve forward and off the mounting bracket.
- Disconnect the water inlet tube from the float valve at the compression fitting.
- Remove the cap and filter screen for cleaning.

G. Remove the Water Trough

- Apply downward pressure on the siphon tube and remove from the bottom of the water trough.
- Remove the upper thumbscrew.
- While supporting the water trough remove the two thumbscrews from beneath the water trough.
- Remove the water trough from the bin area.

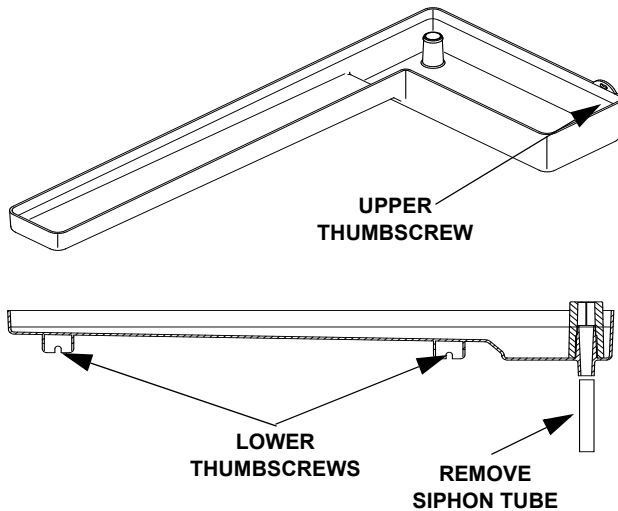
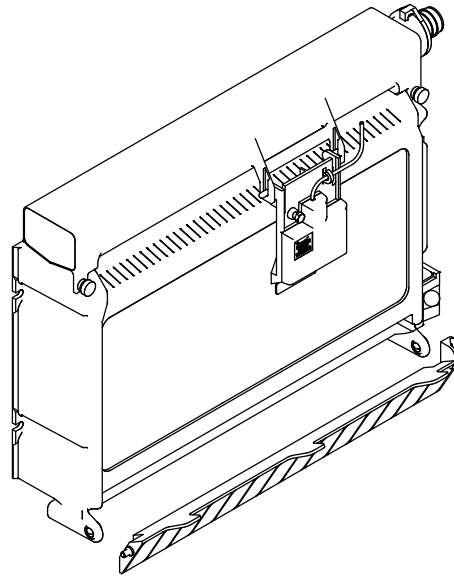
**H. Remove the ice damper.**

- Grasp ice damper and apply pressure toward the left hand mounting bracket.
- Apply pressure to the right hand mounting bracket with thumb.
- Pull ice damper forward when the right hand ice damper pin disengages.

Installation

- Place ice damper pin in left hand mounting bracket and apply pressure toward the left hand mounting bracket.
- Apply pressure to the right hand mounting bracket with thumb.
- Push ice damper toward evaporator until right hand damper pin engages.

I. Remove the Bin Door

- Grasp the rear of the bin door and pull bin door forward approximately 5" (13 cm).
- Slide bin door to the rear while applying upward pressure (The rear door pins will ride up into the track slot and slide backward to the stop tab).
- While applying pressure against the bin door pull down on the rear of each bin door track until the door pins clear the stop tabs.
- Slide the rear door pins off the end and then below the door track. Slide bin door forward allowing the back of the door to lower into the bin. Continue forward with the bin door until the front pins bottom out in the track.
- Lift right side of door until the front pins clear the track, then remove door from bin.

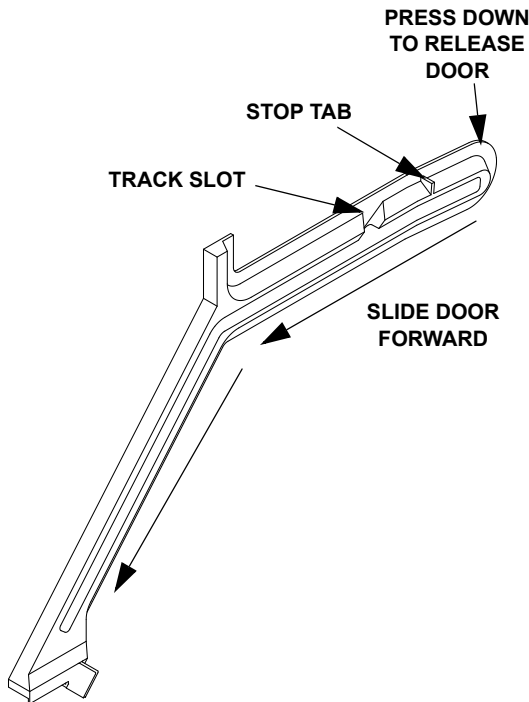

Step 7 Mix a solution of de-scaler and warm water. Depending on the amount of mineral buildup, a larger quantity of solution may be required. Use the ratio in the table below to mix enough solution to thoroughly clean all parts.

Solution Type	Water	Mixed with
De-scaler	1 gal. (4 l)	16 oz (500 ml) de-scaler

Step 8 Use 1/2 of the de-scaler/water solution to clean all components. The de-scaler solution will foam when it contacts lime scale and mineral deposits; once the foaming stops use a soft bristle brush, sponge or cloth (not a wire brush) to carefully clean the parts. Soak the parts for 5 minutes (15 – 20 minutes for heavily scaled parts). Rinse all components with clean water.

Step 9 While components are soaking, use 1/2 of the de-scaler/water solution to clean all foodzone surfaces of the ice machine and bin. Use a nylon brush or cloth to thoroughly clean the following ice machine areas:

- Evaporator plastic parts – including top, bottom and sides
- Bin bottom, sides and top

Rinse all areas thoroughly with clean water.

Step 10 Mix a solution of sanitizer and warm water.

Solution Type	Water	Mixed With
Sanitizer	6 gal. (23 l)	4 oz (120 ml) sanitizer

Step 11 Use 1/2 of the sanitizer/water solution to sanitize all removed components. Use a cloth or sponge to liberally apply the solution to all surfaces of the removed parts or soak the removed parts in the sanitizer/water solution. Do not rinse parts after sanitizing.



Step 12 Use 1/2 of the sanitizer/water solution to sanitize all foodzone surfaces of the ice machine and bin. Use a cloth or sponge to liberally apply the solution. When sanitizing, pay particular attention to the following areas:

- Evaporator plastic parts - including top, bottom and sides
- Bin bottom, sides and top

Do not rinse the sanitized areas.

Step 13 Replace all removed components.

Step 14 Reapply power and water to the ice machine and place the toggle switch in the WASH position.

Step 15 Add the proper amount of Manitowoc Ice Machine Sanitizer to the water trough.

Model	Amount of Sanitizer
UDE(P)0080A	1.5 ounces (45 ml)

Step 16 Wait until the sanitize cycle is complete (approximately 22 minutes) then place the toggle switch in the OFF position, disconnect power and water supplies to the ice machine.

 **Warning**

Disconnect electric power to the ice machine at the electric switch box before proceeding.

Step 17 Repeat step 6 to remove parts for hand sanitizing.

Step 18 Mix a solution of sanitizer and warm water.

Solution Type	Water	Mixed With
Sanitizer	6 gal. (23 l)	4 oz (120 ml) sanitizer

Step 19 Use 1/2 of the sanitizer/water solution to sanitize all removed components. Use a cloth or sponge to liberally apply the solution to all surfaces of the removed parts or soak the removed parts in the sanitizer/water solution. Do not rinse parts after sanitizing.

Step 20 Use 1/2 of the sanitizer/water solution to sanitize all foodzone surfaces of the ice machine and bin. Use a cloth or sponge to liberally apply the solution. When sanitizing, pay particular attention to the following areas:

- Evaporator plastic parts - including top, bottom and sides
- Bin bottom, sides and top

Do not rinse the sanitized areas.

Step 21 Replace all removed components.

Step 22 Reapply power and water to the ice machine and place the toggle switch in the ICE position.

Exterior Cleaning

Clean the area around the ice machine as often as necessary to maintain cleanliness and efficient operation.

Sponge any dust and dirt off the outside of the ice machine with mild soap and water. Wipe dry with a clean, soft cloth.

A commercial grade stainless steel cleaner/polish can be used as necessary.



Cleaning the Condenser

Warning

Disconnect electric power to the ice machine at the electric service switch before cleaning the condenser.

A dirty condenser restricts airflow, resulting in excessively high operating temperatures. This reduces ice production and shortens component life. Clean the condenser at least every six months. Follow the steps below.

Warning

The condenser fins are sharp. Use care when cleaning them.

1. The washable aluminum filter on self-contained ice machines is designed to catch dust, dirt, lint and grease. This helps keep the condenser clean. Clean the filter with a mild soap and water solution.
2. Clean the outside of the condenser with a soft brush or a vacuum with a brush attachment. Clean from top to bottom, not side to side. Be careful not to bend the condenser fins.
3. Shine a flashlight through the condenser to check for dirt between the fins. If dirt remains: Blow compressed air through the condenser fins from the inside. Be careful not to bend the fan blades.
4. Use a commercial condenser coil cleaner. Follow the directions and cautions supplied with the cleaner.
5. Straighten any bent condenser fins with a fin comb.
6. Carefully wipe off the fan blades and motor with a soft cloth. Do not bend the fan blades. If the fan blades are excessively dirty, wash with warm, soapy water and rinse thoroughly.

Caution

If you are cleaning the condenser fan blades with water, cover the fan motor to prevent water damage.

Removal from Service/Winterization

Special precautions must be taken if the ice machine is to be removed from service for an extended period of time or exposed to ambient temperatures of 32°F (0°C) or below.

Caution

If water is allowed to remain in the ice machine in freezing temperatures, severe damage to some components could result. Damage of this nature is not covered by the warranty.

Follow the applicable procedure below.

1. Disconnect the electric power at the circuit breaker or the electric service switch.
2. Turn off the water supply.
3. Remove the water from the water trough.
4. Disconnect and drain the incoming ice-making water line at the rear of the ice machine.
5. Blow compressed air in both the incoming water and the drain openings in the rear of the ice machine until no more water comes out of the inlet water lines or the drain.
6. Make sure water is not trapped in any of the water lines, drain lines, distribution tubes, etc.

THIS PAGE INTENTIONALLY LEFT BLANK



Section 5

Customer Support

Checklist

If a problem arises during operation of your ice machine, follow the checklist below before calling service. Routine adjustments and maintenance procedures are not covered by the warranty.

Problem	Possible Cause	To Correct
Ice machine does not operate.	No electrical power to the ice machine.	Replace the fuse/reset the breaker/turn on the main switch/plug power cord into receptacle.
	ON/OFF/ WASH toggle switch set improperly.	Move the toggle switch to the ON position.
	Damper in open position (down).	Damper must be in upright position and capable of swinging freely.
Ice machine stops, and can be restarted by moving the toggle switch to OFF and back to ICE.	Safety limit feature stopping the ice machine.	Refer to "Safety Limit Feature" on the next page.
Ice machine does not release ice or is slow to harvest.	Ice machine is dirty.	Clean and sanitize the ice machine.
	Ice machine is not level.	Level the ice machine.
	Low air temperature around ice machine.	Air temperature must be at least 35°F (2°C).
Ice machine does not cycle into harvest mode.	The six-minute freeze time lock-in has not expired yet.	Wait for freeze lock-in to expire.
	Ice thickness probe is dirty.	Clean and sanitize the ice machine.
	Ice thickness probe wire is disconnected.	Connect the wire.
	Ice thickness probe is out of adjustment.	Adjust the ice thickness probe.
	Uneven ice fill (thin at top of evaporator).	See "Shallow or Incomplete Cubes" on the next page.
Ice quality is poor (soft or not clear).	Poor incoming water quality.	Contact a qualified service company to test the quality of the incoming water and make appropriate filter recommendations.
	Water filtration is poor.	Replace the filter.
	Ice machine is dirty.	Clean and sanitize the ice machine.
	Water siphon is not working.	Check the water siphon system.
	Water softener is working improperly (if applicable).	Repair the water softener.

Continued on next page...



Problem	Possible Cause	To Correct
Ice machine produces shallow or incomplete cubes, or the ice fill pattern on the evaporator is incomplete.	Ice thickness probe is out of adjustment.	Adjust the ice thickness probe.
	Water trough level is too high or too low.	Check the water level.
	Water float valve filter screen is dirty.	Remove and clean the filter screen.
	Water filtration is poor.	Replace the filter.
	Hot incoming water.	Connect the ice machine to a cold water supply.
	Water float valve is not working.	Remove the water float valve and clean it.
	Incorrect incoming water pressure.	Water pressure must be 20-80 psi (137.9 - 551.5 kPa).
	Ice machine is not level.	Level the ice machine.
Low ice capacity.	Water float valve filter screen is dirty.	Remove and clean the filter screen.
	Incoming water supply is shut off.	Open the water service valve.
	Water float valve stuck open or leaking.	Remove the water float valve and clean it.
	The condenser is dirty.	Clean the condenser.
	High air temperature around ice machine.	Air temperature must not exceed 110°F (43°C).
	Inadequate clearance around the ice machine.	Provide adequate clearance.
	Objects stacked around ice machine, blocking airflow to condenser.	Remove items blocking airflow.

Safety Limit Feature

In addition to the standard safety controls, your Manitowoc ice machine features built-in safety limits that will stop the ice machine if conditions arise which could cause a major component failure.

Before calling for service, re-start the ice machine using the following procedure:

1. Move the ON/OFF/ WASH switch to OFF and then back to ON.
 - A. If the safety limit feature has stopped the ice machine, it will restart after a short delay. Proceed to step 2.
 - B. If the ice machine does not restart, see "Ice machine does not operate" on the previous page.
2. Allow the ice machine to run to determine if the condition is reoccurring.
 - A. If the ice machine stops again, the condition has reoccurred. Call for service.
 - B. If the ice machine continues to run, the condition has corrected itself. Allow the ice machine to continue running.

Commercial Ice Machine Warranty

Pentair Inc. (hereinafter referred to as the "COMPANY") warrants for a period of thirty-six months from the installation date (except as limited below) that new ice machines manufactured by the COMPANY shall be free of defects in material or workmanship under normal and proper use and maintenance as specified by the COMPANY and upon proper installation and start-up in accordance with the instruction manual supplied with the ice machine. The COMPANY's warranty hereunder with respect to the compressor shall apply for an additional twenty-four months, excluding all labor charges, and with respect to the evaporator for an additional twenty-four months, including labor charges.

The obligation of the COMPANY under this warranty is limited to the repair or replacement of parts, components, or assemblies that in the opinion of the COMPANY are defective. This warranty is further limited to the cost of parts, components or assemblies and standard straight time labor charges at the servicing location.

Time and hourly rate schedules, as published from time to time by the COMPANY, apply to all service procedures. Additional expenses including without limitation, travel time, overtime premium, material cost, accessing or removal of the ice machine, or shipping are the responsibility of the owner, along with all maintenance, adjustments, cleaning, and ice purchases. Labor covered under this warranty must be performed by a COMPANY Contracted Service Representative or a refrigeration service agency as qualified and authorized by the COMPANY's local Distributor. The COMPANY's liability under this warranty shall in no event be greater than the actual purchase price paid by customer for the ice machine.

The foregoing warranty shall not apply to (1) any part or assembly that has been altered, modified, or changed; (2) any part or assembly that has been subjected to misuse, abuse, neglect, or accidents; (3) any ice machine that has been installed and/or maintained inconsistent with the technical instructions provided by the COMPANY; or (4) any ice machine initially installed more than five years from the serial number production date. This warranty shall not apply if the Ice Machine's refrigeration system is modified with a condenser, heat reclaim device, or parts and assemblies other than those manufactured by the COMPANY, unless the COMPANY approves these modifications for specific locations in writing.

THIS WARRANTY IS IN LIEU OF ALL OTHER WARRANTIES OR GUARANTEES OF ANY KIND, EXPRESSED OR IMPLIED, INCLUDING ANY IMPLIED WARRANTY OF MERCHANTABILITY OR FITNESS FOR A PARTICULAR PURPOSE. In no event shall the COMPANY be liable for any special, indirect, incidental or consequential damages. Upon the expiration of the warranty period, the COMPANY's liability under this warranty shall terminate. The foregoing warranty shall constitute the sole liability of the COMPANY and the exclusive remedy of the customer or user.

To secure prompt and continuing warranty service, the warranty registration card must be completed and sent to the COMPANY within five (5) days from the installation date.

Complete the following and retain for your record:

Distributor/Dealer _____

Model Number _____ Serial Number _____

Installation Date _____

MANITOWOC ICE.
 2110 So. 26th St., P.O. Box 1720, Manitowoc, WI 54220-1720
 Telephone:844-724-2273 • Fax: 920-683-7585
 Web Site - www.manitowocice.com
 Form 80-0375-3 Rev. 01-18



Residential Ice Machine Limited Warranty

WHAT DOES THIS LIMITED WARRANTY COVER?

Subject to the exclusions and limitations below, Manitowoc warrants to the original consumer that any new ice machine manufactured by Manitowoc (the "Product") shall be free of defects in material or workmanship for the warranty period outlined below under normal use and maintenance, and upon proper installation and start-up in accordance with the instruction manual supplied with the Product.

HOW LONG DOES THIS LIMITED WARRANTY LAST?

<u>Product Covered</u>	<u>Warranty Period</u>
Ice Machine	Twelve (12) months from the sale date

WHO IS COVERED BY THIS LIMITED WARRANTY?

This limited warranty only applies to the original consumer of the Product and is not transferable.

WHAT ARE Manitowoc'S OBLIGATIONS UNDER THIS LIMITED WARRANTY?

If a defect arises and Manitowoc receives a valid warranty claim prior to the expiration of the warranty period, Manitowoc shall, at its option: (1) repair the Product at Manitowoc's cost, including standard straight time labor charges, (2) replace the Product with one that is new or at least as functionally equivalent as the original, or (3) refund the purchase price for the Product. Replacement parts are warranted for 90 days or the balance of the original warranty period, whichever is longer. The foregoing constitutes Manitowoc's sole obligation and the consumer's exclusive remedy for any breach of this limited warranty. Manitowoc's liability under this limited warranty is limited to the purchase price of Product. Additional expenses including, without limitation, service travel time, overtime or premium labor charges, accessing or removing the Product, or shipping are the responsibility of the consumer.

HOW TO OBTAIN WARRANTY SERVICE

To obtain warranty service or information regarding your Product, please contact us at:

MANITOWOC ICE
2110 So. 26th St.
P.O. Box 1720,
Manitowoc, WI 54220-1720
Telephone: 800-545-5720 Fax: 920-683-7585
www.manitowocice.com

WHAT IS NOT COVERED?

This limited warranty does not cover, and you are solely responsible for the costs of: (1) periodic or routine maintenance, (2) repair or replacement of the Product or parts due to normal wear and tear, (3) defects or damage to the Product or parts resulting from misuse, abuse, neglect, or accidents, (4) defects or damage to the Product or parts resulting from improper or unauthorized alterations, modifications, or changes; and (5) defects or damage to any Product that has not been installed and/or maintained in accordance with the instruction manual or technical instructions provided by Manitowoc. To the extent that warranty exclusions are not permitted under some state laws, these exclusions may not apply to you.

EXCEPT AS STATED IN THE FOLLOWING SENTENCE, THIS LIMITED WARRANTY IS THE SOLE AND EXCLUSIVE WARRANTY OF MANITOWOC WITH REGARD TO THE PRODUCT. ALL IMPLIED WARRANTIES ARE STRICTLY LIMITED TO THE DURATION OF THE LIMITED WARRANTY APPLICABLE TO THE PRODUCTS AS STATED ABOVE, INCLUDING BUT NOT LIMITED TO, ANY WARRANTY OF MERCHANTABILITY OR OF FITNESS FOR A PARTICULAR PURPOSE.

Some states do not allow limitations on how long an implied warranty lasts, so the above limitation may not apply to you.

IN NO EVENT SHALL MANITOWOC OR ANY OF ITS AFFILIATES BE LIABLE TO THE CONSUMER OR ANY OTHER PERSON FOR ANY INCIDENTAL, CONSEQUENTIAL OR SPECIAL DAMAGES OF ANY KIND (INCLUDING, WITHOUT LIMITATION, LOSS PROFITS, REVENUE OR BUSINESS) ARISING FROM OR IN ANY MANNER CONNECTED WITH THE PRODUCT, ANY BREACH OF THIS LIMITED WARRANTY, OR ANY OTHER CAUSE WHATSOEVER, WHETHER BASED ON CONTRACT, TORT OR ANY OTHER THEORY OF LIABILITY.

Some states do not allow the exclusion or limitation of incidental or consequential damages, so the above limitation or exclusion may not apply to you.

HOW STATE LAW APPLIES

This limited warranty gives you specific legal rights, and you may also have rights that vary from state to state or from one jurisdiction to another.

REGISTRATION CARD

To secure prompt and continuing warranty service, this warranty registration card must be completed and sent to Manitowoc within thirty (30) days from the sale date. Complete the following registration card and send it to Manitowoc.

EC DECLARATION OF CONFORMITY

We hereby declare that our products, ice machines and Multiplex refrigeration equipment comply with all the essential requirements of the listed EC - directives.

Manufacturer:

Manitowoc Ice, Inc.
2110 S. 26th Street, P.O. Box 1720
Manitowoc, Wisconsin 54221-1720 USA

European Distributor:

Representative of Manitowoc Ice, Inc.:

Engineering Manager, (Printed name)

Signature

Representative of European Distributor:

Model and Serial No.

Applied EC Directives:

Applied Standards:

EN60335-1 Safety of household and similar electrical appliances
EN60335-2-24 Particular requirements refrigerators, food freezers and ice makers

EN55014 Electrical Motor Operated Appliances (Emissions)
EN55014 Electro Magnetic Compatibility (Immunity)
EN378 -1 to -4 Refrigeration Plants

Low Voltage 73/23/EEC
EMC 89/336/EEC
Pressure Equipment 97/23/EC



8201043
08/25/03



MANITOWOC ICE
2110 South 26th Street,
Manitowoc, WI 54220
Ph: 844-724-2273

Visit us online at: WWW.MANITOWOCICE.COM

© 2010 Manitowoc

Continuing product improvements may necessitate change of specifications without notice.

Part Number 040006020 08/22

