



## McGrathlocks APP INSTALLATION REQUIRED

Enable your smart phone to scan QR code to download the APP. Also you can search "McGrathlocks" on APP store or Google play to download the APP.

### Exploded diagram

#### Exterior Lock Diagram

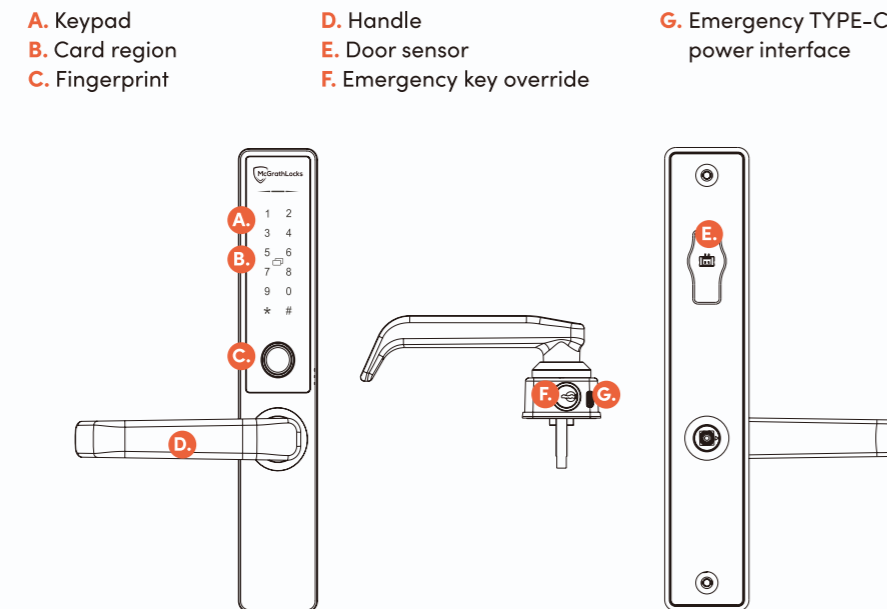

#### Interior Lock Diagram

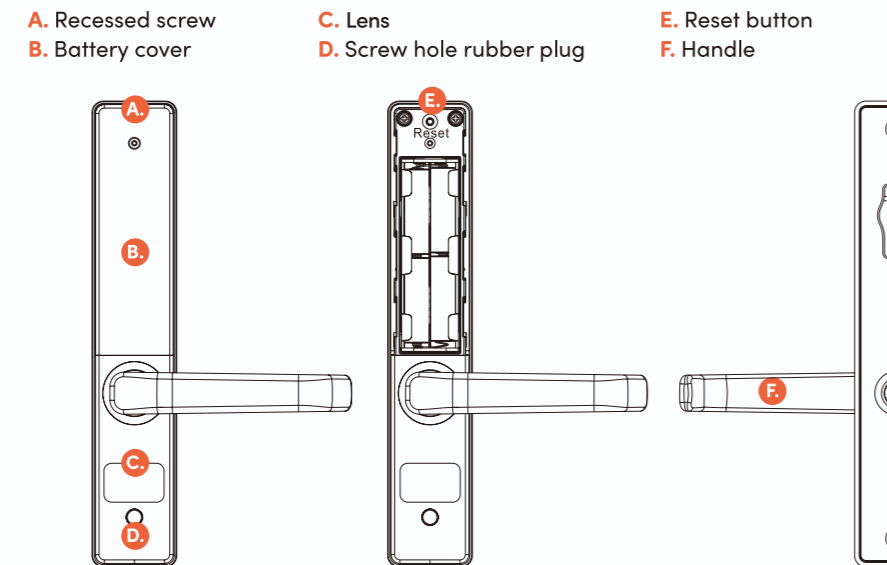

### 1. Adjust the handle direction

The smart door lock is suitable for left hand and right hand opening door. As shown in the figure below, loosen the screw on the inside of the handle with the hex wrench. Rotate the handle 90 degrees to the left or right and re-tighten the screw, then apply threadlock to the threads of the screws and retighten them.

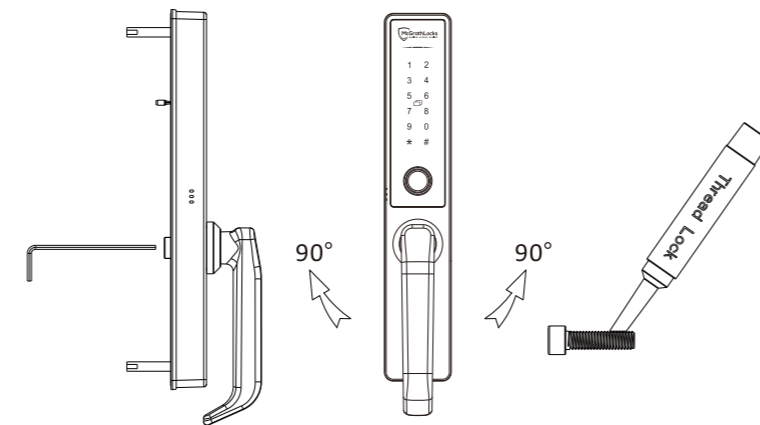

### 2. Dismantle the mounting plate from the interior lock

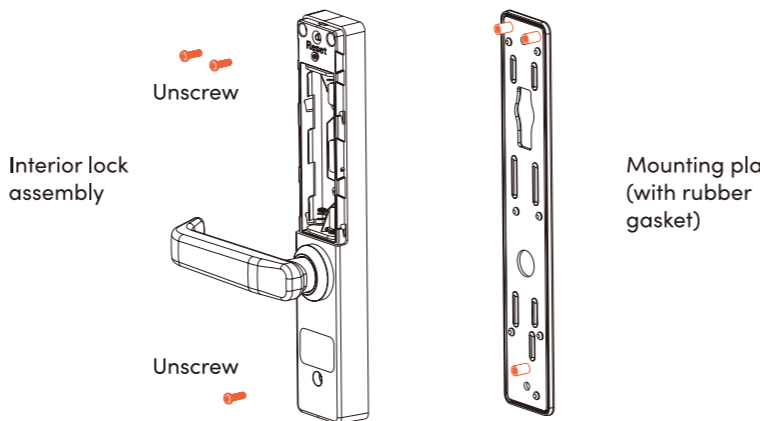

### 3. Tighten 2 screw studs on the exterior lock metal plate

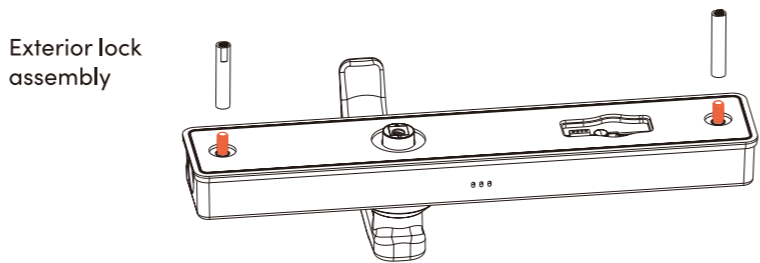

### Tubular latch and Australian mortice lock installation

1 Rotate the hub so the triangle icon points to the top of the lock assembly. Door handing does not matter for this setup.

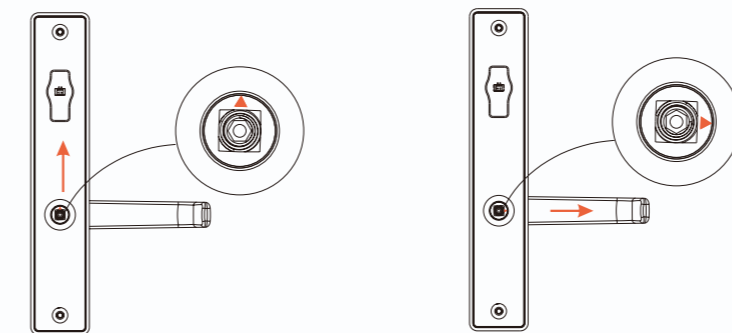

### 4. Install door sensor (optional)

A. Install the door sensor into the door and feed the cable through the hole.  
B. Connect the door sensor cable to the exterior lock assembly.

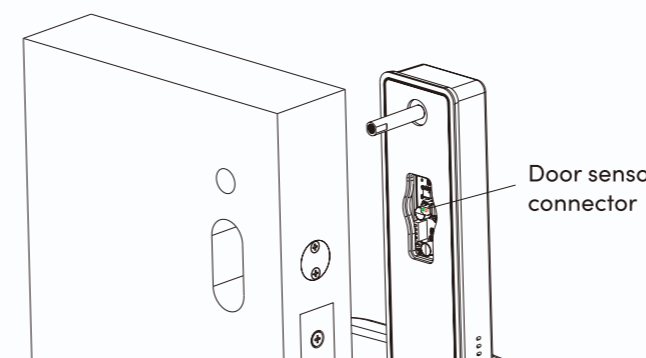

### 5. Install exterior lock assembly

A. Slide the spindle through the hub of the latch or mortice lock and feed the connecting cable through the top hole while placing the exterior lock assembly on the door. Ensure that the spindle sits within the lock hub.  
B. Position the inside mounting plate on the door and feed the connecting cable through the top hole in the plate.  
C. Use the two main fixing screws to attach the exterior lock assembly to the interior mounting plate but do not fully tighten.

### Mortice lock with deadbolt feature installation (where lifting the lever throws the mortice bolt)

1 Rotate the hub so the triangle icon points the same direction as the lock handle

D. Align the mounting plate with the door edge ensuring the spindle is in the middle of the round hole in the mounting plate.  
E. Place the interior lock assembly on the door and check that both levers operate smoothly.  
F. Remove the interior lock assembly, then tighten the two screws.

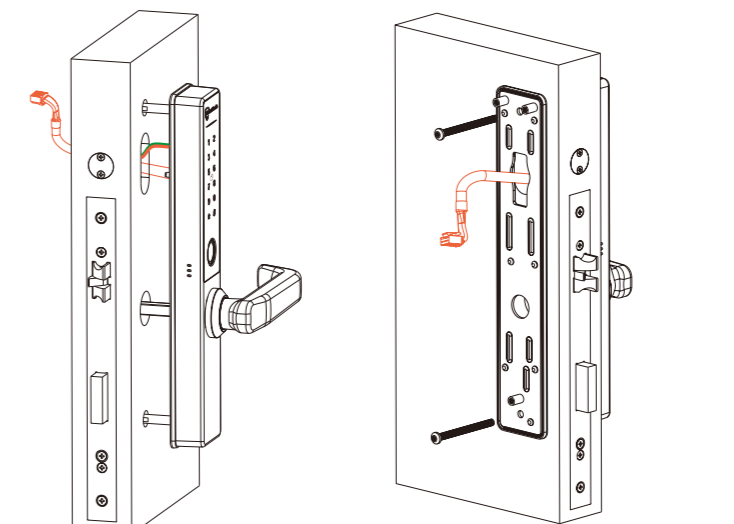

### 6. Install interior lock assembly

A. Connect the cable to interior lock assembly.  
B. Place the interior lock assembly on the mounting plate ensuring not to pinch the connecting cable and tighten the 3 lock case screws.  
C. Test the handle and the mechanical key override.  
D. Insert the rubber plug into the bottom screw hole.  
E. Insert 4 x AA Alkaline batteries.

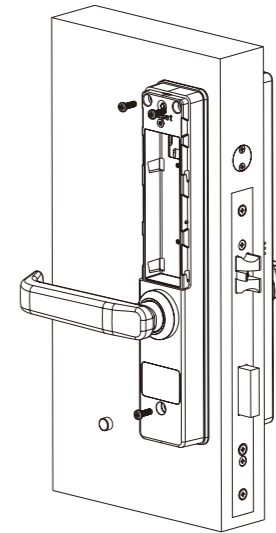

## RECOMMENDED: LOCK SETUP WITH APP

It is highly recommended to set up the lock using the McGrathlocks app.

The app simplifies programming and provides an easier way to manage your locks.



DOWNLOAD & INSTALL

## Manual set up via keypad only

Please follow the instructions below to manually program the lock using the keypad.

You can add a BLE device after the lock is programmed manually provided you know the admin code.



## CREATE NEW ACCESS

Add administrator (only 1)



- Enter \*12#
- Input 123456# (the default code)
- Input new code#
- Repeat new code#

Add a new user with an access / pin code (250 maximum)



- Enter \*80#
- Input admin code#
- Input user code# (6-9 digits)
- Repeat new user code#

Tips: If you use the APP a 4 digit user code can be set.

Add a new user with an RFID card (1000 maximum)



- Enter \*80#
- Input admin code#
- Present the card to the card sensor area

Add a new user with fingerprint (100 maximum)



- Enter \*80#
- Input admin code#
- Present fingerprint several times according to the voice guide.

## MODIFY CODE

Modify admin code



- Enter \*12#
- Input old admin code#
- Input new admin code#
- Repeat the new admin code#

Modify user code



- Enter \*10#
- Input old user code#
- Input new user code#
- Repeat the new user code#

## DELETE USER

Delete specified pin code



- Enter \*72#
- Input admin code#
- Input the specified code# that you wanted to delete

Tips: The admin code cannot be deleted.

Delete all user codes



- Enter \*71#
- Input admin code#

## MANAGE VOICE

Turn on the lock voice



- Enter \*30#
- Input admin code#
- Input 1#

## MANAGE DOORBELL

Turn on doorbell



- Enter \*34#
- Input admin code#
- Input 1#

Delete all fingerprints

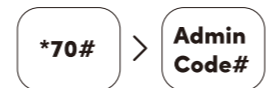

- Enter \*70#
- Input admin code#

Delete all RFID cards



- Enter \*69#
- Input admin code#

Turn off the lock voice



- Enter \*30#
- Input admin code#
- Input 0#

Turn off doorbell



- Enter \*34#
- Input admin code#
- Input 0#

## MANAGE DOOR SENSOR

The alarm sound can be set between 0-60 seconds, 0 being no alarm



Note: Input "0" to turn off the door sensor. Inputting "30" means the door sensor will trigger after 30 seconds of door being open.

## RESET THE LOCK

Press and hold the reset button until you hear "please input initialization passcode" then input 000#. All pin codes, cards, BLE and fingerprint users will be deleted.

## DEMO MODE

Demo mode is turned off by default prior to an Admin code being registered. If you wish to turn on demo mode input 24679#. Demo mode sets the lock access pin code to 123456# and any card or fingerprint will also open it. Registering an Administrator will take the lock out of demo mode.

## LOW BATTERY ALERT

When battery power is less than 4.8V you will hear a low battery alert each time you wake the lock screen. Please replace batteries with new Alkaline type. Don't mix old and new batteries.

## SCRAMBLING CODE FOR ANTI PEEP

Users may enter any random digits before or/and at the end of entering their correct pin code and still gain access. This feature makes it harder for an unauthorised user who may be watching you to guess your pin code.

## INCORRECT CODE / CARD ALERT

If the wrong unlocking information is inputted five times the system will be locked out for 35 seconds. The lock can only be operated by the APP during the lockout period.

## PASSAGE MODE

Passage mode keeps the door unlocked, useful when gardening or bringing in groceries from the car etc.

To activate passage mode, enter a valid unlock code then press 123# within 5 seconds. The door will remain unlocked.

To remove from passage mode, unlock using a valid code or card. If you engage passage mode via the APP you must use the APP to disengage passage mode.

## FAQS

**Keypad on lock does not respond**

- Please check the batteries are installed correctly.
- If the lock had been working OK please replace the batteries with new AA Alkaline type.

**The door will not lock**

- Ensure the lock is not in demo mode.
- Check to see if the lock is in passage mode.
- Refer to installation guide to ensure the triangle on the lock hub is correctly aligned.

**Battery performance is poor.**

- Ensure all batteries are new Alkaline type.
- Ensure the lock connecting cable is not pinched.
- Check for and update lock firmware.

## GATEWAY Gateway type

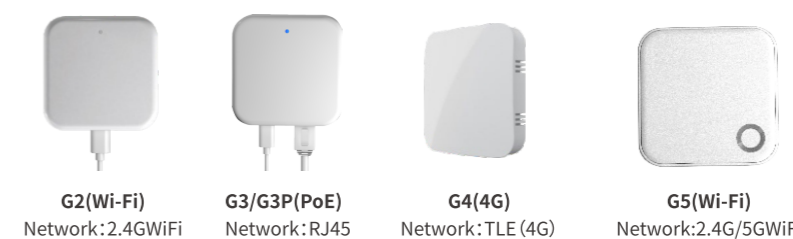

## Add Gateway

- Open the McGrath Locks app and log in to your administrator account.
- Tap the menu icon (☰) in the top left corner of the home screen.
- Select "Gateway" from the sidebar menu.
- Tap the "+" symbol in the top right corner.
- Choose your gateway model from the list provided.
- Connect the gateway to power, while the light is alternatively flashing red and blue, press the "+" symbol.
- Select the network required, enter the Wi-Fi password, enter the gateway name.

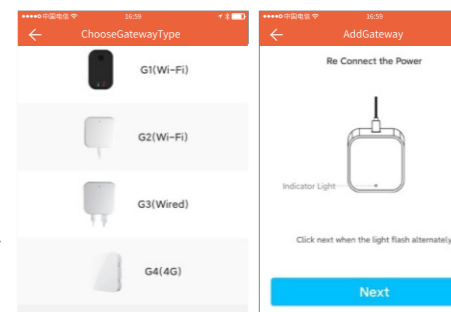

- Notice: If the process times out, please disconnect from power and try again.
- \*Gateway coverage distance: 10 meters without obstruction.

## GATEWAY FUNCTIONALITY

The gateway is an accessory for the lock that connects it to the network. With a gateway connected you can remotely manage the lock, such as opening the door or deleting a passcode.

Gateway Functions

	Without Gateway	With Gateway	
Assign random pin codes	✓	✓	The door lock can function normally without a gateway. However, to remotely modify or delete pin codes, issue fingerprints or cards, open the door remotely and access other features, a gateway is required.
Door Opening with App	✓	✓	
Set permissions	✓	✓	
Remotely modify and delete pin codes	✗	✓	
Remote card issuance	✗	✓	
Open door remotely	✗	✓	
Upload door records log in real time	✗	✓	

## FCC Caution

Any Changes or modifications not expressly approved by the party responsible for compliance could void the user's authority to operate the equipment.

This device complies with part 15 of the FCC Rules. Operation is subject to the following two conditions: (1) This device may not cause harmful interference, and (2) this device must accept any interference received, including interference that may cause undesired operation.

## IMPORTANT NOTE

Note: This equipment has been tested and found to comply with the limits for a Class B digital device, pursuant to part 15 of the FCC Rules. These limits are designed to provide reasonable protection against harmful interference in a residential installation. This equipment generates, uses and can radiate radio frequency energy and, if not installed and used in accordance with the instructions, may cause harmful interference to radio communications. However, there is no guarantee that interference will not occur in a particular installation. If this equipment does cause harmful interference to radio or television reception, which can be determined by turning the equipment off and on, the user is encouraged to try to correct the interference by one or more of the following measures:

- Reorient or relocate the receiving antenna.
- Increase the separation between the equipment and receiver.
- Connect the equipment into an outlet on a circuit different from that to which the receiver is connected.
- Consult the dealer or an experienced radio/TV technician for help.

## FCC Radiation Exposure Statement:

This equipment complies with FCC radiation exposure limits set forth for an uncontrolled environment. This equipment should be installed and operated with minimum distance 20cm between the radiator & your body.