

Gasmate®

FORTUNA

4 & 6 BURNER BBQ

4 BURNER - BQ1070F

6 BURNER - BQ1071F



- Deluxe BBQ featuring vitreous enamel body
- Stainless steel hood includes glass window and temperature gauge
- Stylish cabinet
- Rotary ignition
- Stainless steel tube burners
- Satin enamel cast iron grill and reversible hotplate
- Operates on Universal L.P.G.
- Gas certified to Australian Standards

Important: Retain these instructions for future use

03610 07/17

Gasmate® is a registered trademark of
Sitro Group Australia Pty Ltd. www.gasmate.com.au
Aber, N.Z. www.gasmate.co.nz

READ ME FIRST



GAS LEAK TESTING

It is important that you leak test the BBQ before first use and every time the gas cylinder is refilled and reconnected to the BBQ.

To Complete Leak Test

- Make sure all the control knobs are OFF.
- In a small container, mix up a solution of water and detergent/soap.
- Mix the solution well (about the same concentrate as washing up water).
- Turn the cylinder ON by rotating the knob anti-clockwise.
- Using a brush or spray bottle apply the soap solution to the gas line and each join in the gas line including:
 - the gas connection at the inlet of the BBQ
 - all gas hose connections
 - the gas connection at the gas cylinder
- If bubbles appear, there is a gas leak.
- If the leak is at the hose connection, re-tighten and re-seal.
- If the leak is anywhere else or you cannot resolve the leak by tightening the connection DO NOT PROCEED.
- Turn the gas cylinder off clockwise.

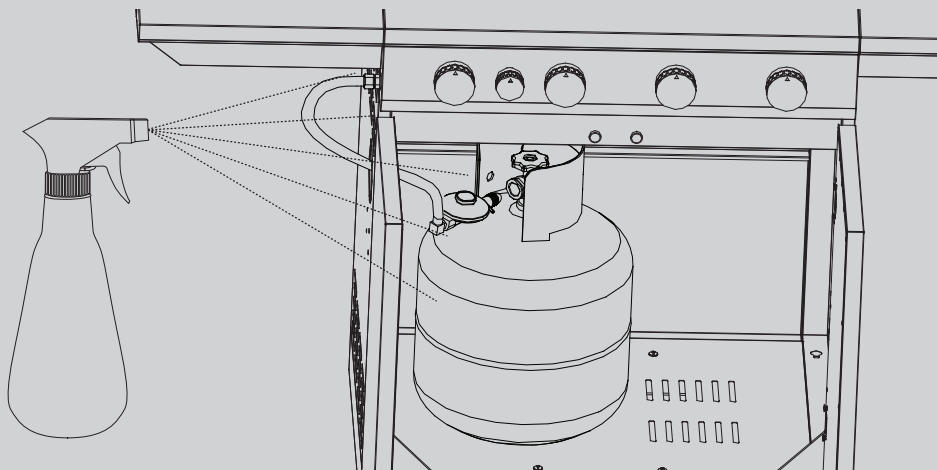

GENERAL INFORMATION



IMPORTANT

Read these instruction carefully prior to use. Familiarise yourself with the appliance before connecting it to it's gas container. Keep these instructions for future reference.



IF YOU SMELL GAS

1. Shut off gas to the barbecue at its source, if possible.
2. Extinguish any open flame.
3. Open hood.
4. If odour continues immediately call your gas supplier or fire department.

Hose & Regulator Safety

The regulator and hose assembly supplied with the barbecue are suitable for Propane Gas or Universal L.P.G. only.

A gas regulator adjusted to have an outlet pressure of 2.75kPa is supplied for connection to the propane gas cylinder. The pressure regulator and hose assembly supplied with the barbecue must me used. Replacement pressure regulators and hose assemblies must be those specified by the barbecue manufacturer.

When connecting the hose and regulator assembly to the gas cylinder, take care to avoid unnecessary twisting of the flexible hose.

After the assembly has been secured, turn on the gas and check for leaks by brushing a soap and water solution over all connections.

If you are unable to correct the leak by tightening the connections, turn off the gas and contact the supplier immediately.

Always ensure the barbecue is kept away from flammable materials and the gas cylinder clear of any heat source.

When changing over from an empty gas cylinder to a full one make sure this procedure is carried out in a well ventilated location, preferably outside, away from people and away from any sources of ignition; such as naked flames, pilot flames, electric heaters/equipment.

Gas Cylinder Use & Safety

This is a low pressure barbecue and must only be used with the regulator supplied. Your barbecue is designed for use with 4.5Kg or 9Kg propane gas cylinders certified to AS 2469.

The gas cylinder should be filled by a reputable gas supplier and visually inspected and re-qualified at each filling.

Always keep cylinder in an upright position. Always close the cylinder valve when the barbecue is not in use.

Do not subject gas cylinder to excessive heat.

NEVER STORE YOUR GAS CYLINDER INDOORS.

If you store your barbecue indoors, ALWAYS disconnect the gas cylinder first and store the cylinder safely outside.

Cylinders must be stored outdoors in a well ventilated area out of reach of children, and must not be stored in a building, garage or any other enclosed area.

Gas Installation Codes

- Barbecues must be used in accordance with the installation requirements of your gas supply authority, or the Australian Standard AS 5601.
- Barbecues for use with bottled gas are labelled 'propane gas' or 'Universal L.P.G'.
- Barbecues for use with natural gas are labelled 'natural gas' and must be installed by an authorised person. Check the gas type sticker attached to the barbecue.

Clearances

Minimum Clearances from combustibile materials must be:

Rear - 600mm Sides - 600mm Above - 1500mm

Specifications

Barbecue specifications can be found on the data label attached to the barbecue body.

Hose connection thread is 1/4" B.S.P.

GENERAL INFORMATION



FOR YOUR SAFETY

Failure to comply with these instructions could result in a fire or explosion which could cause serious bodily injury, death or property damage.

CAUTION: Accessible parts may be very hot.

Keep young children away.

Any modifications of this barbecue may be dangerous.

DO NOT move this barbecue during use.

Turn off gas supply at the gas cylinder after use.

Parts sealed by the manufacturer or their agent must not be manipulated by the user. This barbecue is only to be used and stored outdoors.

- Never operate this barbecue without a regulator.
- Do not test for gas leaks with an open flame.
- If this information is not followed exactly a fire causing death or serious injury may occur. Do not store a spare gas cylinder under or near this barbecue. This barbecue is only to be used and stored outdoors.
- If there is a leak on your appliance (smell of gas) immediately attempt to turn off the cylinder valve. Remove the appliance to a well ventilated location away from any ignition source. Only check for leaks outdoors using soapy water. DO NOT try to detect leaks using a flame.
- Check for leaks by brushing a soap and water solution over all connections. If you are unable to correct the leak by tightening the connections, turn off the gas and contact customer service immediately
- DO NOT replace the grill with an extra hotplate. The warranty will be voided and it violates the gas approval, the grill provides the ventilation needed for the BBQ to operate safely. It is not designed to be a solid hotplate device.
- Do not store or use petrol or other flammable liquids in the vicinity of this or any other appliance.
- Do not store empty or full spare gas cylinders under or near this or any other appliance.
- Keep the gas hose away from hot surfaces and protect from dripping grease. Avoid unnecessary twisting of hose. Visually inspect the hose prior to each use for cracks, excessive wear or other damage. Replace the hose if necessary.

- Never test for gas leaks with a lit match or open flame. Never light barbecue with hood closed or before checking to ensure the burner tubes are fully seated over gas valve orifices.
- Never lean over cooking surface when lighting.
- Never alter or modify the regulator or gas supply assembly.
- This barbecue must not be used indoors.
- Only use in well ventilated areas.
- CARBON MONOXIDE HAZARD - USING THIS APPLIANCE IN AN ENCLOSED SPACE MAY CAUSE DEATH. DO NOT USE IN CARAVANS, TENTS, MARINE CRAFT, CARS, MOBILE HOMES OR SIMILAR LOCATIONS.
- This appliance shall only be used in an above ground open-air situation with natural ventilation, without stagnant areas, where gas leakage and products of combustion are rapidly dispersed by wind and natural convection.
- Ensure the barbecue is set up on a level and stable surface.
- Do not move the barbecue while in use or when hot. Remove the drip tray before moving.

IF THERE IS A LEAK

- Turn the cylinder off.
- Ventilate the area to disperse gas.
- Check all connections.
- If leak persists, keep the cylinder upright. Keep skin away from any gas or liquid escaping from the cylinder.
- Keep the cylinder at least 20 metres away from any sparks or ignition sources, including electrical equipment, camera flashes, engines and motors.
- Disperse gas by encouraging maximum ventilation and spraying with a fine water spray.

IF THERE IS A FIRE

- If the fire is at the barbecue, turn the gas off at the cylinder. Smother the flames with a wet cloth, fire blanket or extinguish using a fire extinguisher.
- If the fire is at the cylinder, or you can not get to the valve to turn the gas off, contact the fire brigade immediately.
- Using a garden hose, direct the water to the middle of the cylinder to keep it cool. Try not to extinguish the flame. At least if the gas is burning, it won't be able to build up pressure and explode.

CARE & MAINTENANCE

Location of your Barbecue

DO NOT use your barbecue in garages, porches, sheds, breezeways, or other enclosed areas. Your barbecue is to be used OUTDOORS. The barbecue is not intended to be installed in or on recreational vehicles and/or boats and should not be placed under any surface that will burn. Do not obstruct the flow of combustion and ventilation air around the barbecue housing.

Protect Children

Keep children away from barbecue during use and until barbecue has cooled after you have finished. Do not allow children to operate barbecue.

Always ensure that no sporting or physical activities are carried out in close proximity to the barbecue during use and while still hot.

Tools You Will Need

Adjustable spanner, Philips head screwdriver.

Check Barbecue for any Damage

Inspect barbecue parts as you proceed. Contact your supplier for assistance regarding replacement of any damaged or missing parts. Do not assemble or operate a barbecue that appears damaged. Barbecues for use with gas cylinders are labelled 'Propane Gas' or 'Universal L.P.G.'. Check labelling at the gas connection on your barbecue.

As with all appliances, proper care and maintenance will keep them in top operating condition and prolong their life. Your new gas barbecue is no exception. By following these cleaning procedures on a timely basis, your barbecue will be kept clean and working properly with minimum effort.

Flash-Back

Spiders and small insects occasionally spin webs or make nests in the burner tubes during warehousing and transit. These webs can lead to a gas flow obstruction which could result in a fire in and around the burner tubes. Cleaning with a soft brush before use and at least every six months is recommended.

This type of fire is known as 'FLASH-BACK' and can cause serious damage to your barbecue and create an unsafe operating condition for the user. Although an obstructed burner tube is not the only cause of 'FLASH-BACK' it is the most common cause and frequent inspection and cleaning of the burner tubes is necessary.

If fire occurs in and around the burner, immediately turn off gas at its source and turn the burner control to 'OFF', wait until the barbecue has cooled, then clean the burner tubes and burner ports.

Cleaning the Cooking Surface

After cooking, turn burner control to 'OFF' and let barbecue cool before attempting to clean the cooking surface. Before first use and periodically, it is suggested that you wash the cooking surface in a mild soap and warm water solution.

Care of Cooking Surface

Use and care of the cooking surface is important. Do not use pans on the cooking surface. Do not overheat the cooking surface with the hood down or no food on the cooking surface.

Cleaning the Drip Tray

To avoid fat or grease dripping from the barbecue remove and empty the drip tray after each use. Wait until the drip tray is cool to touch before disposing of contents.

The drip tray should be washed periodically in a mild detergent and warm water solution.









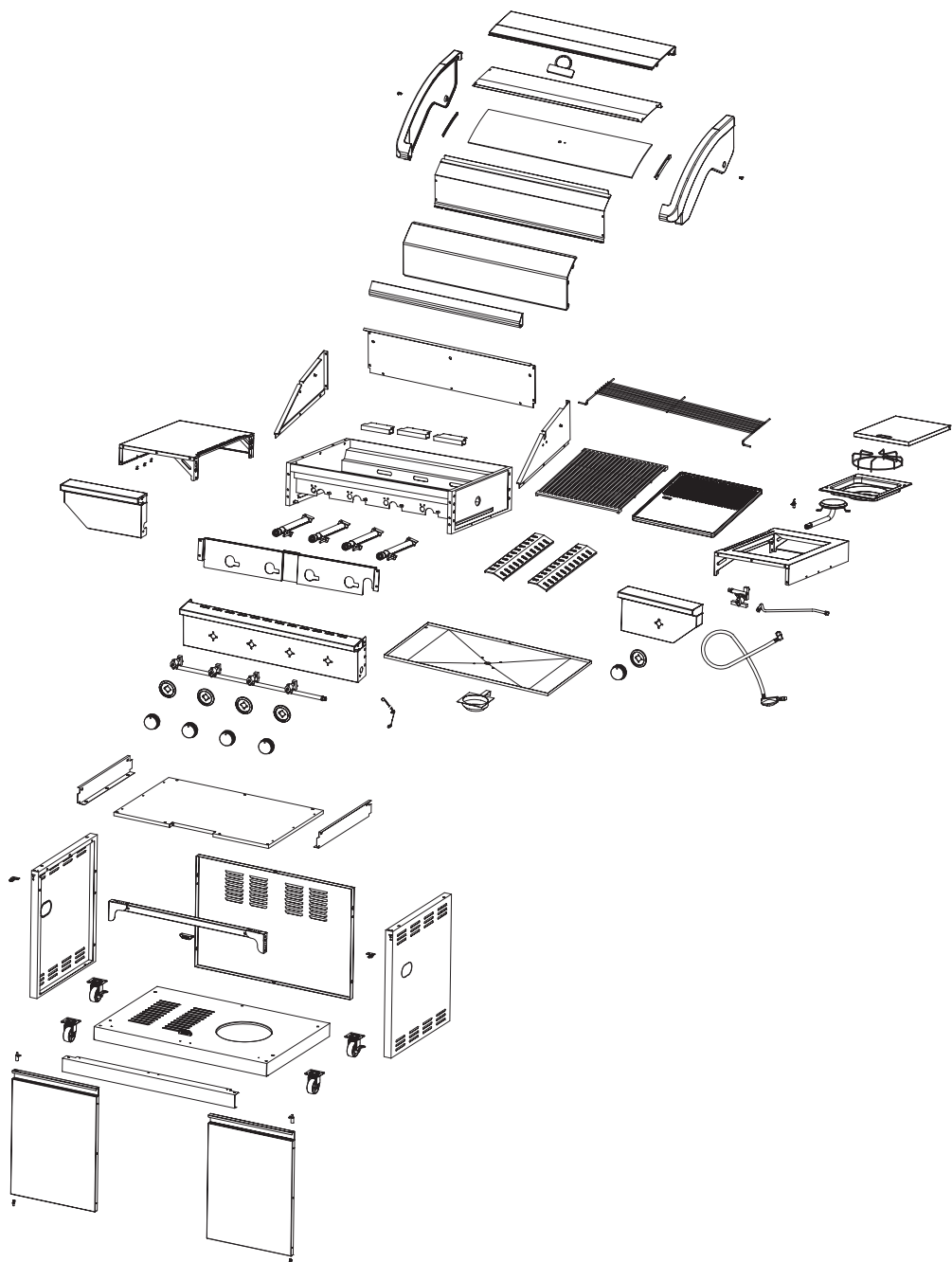



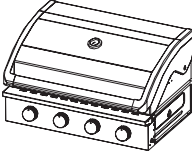

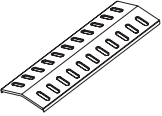
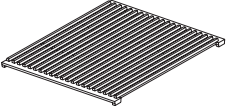
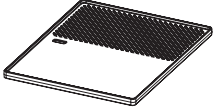
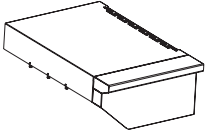
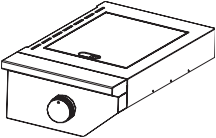
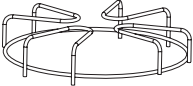
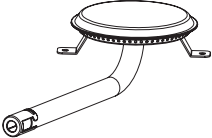
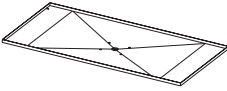
IMPORTANT

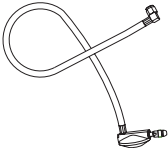
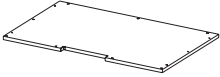
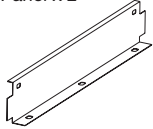
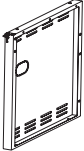
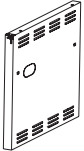
- Beware of spiders and wasps. Burner tube should be inspected and cleaned periodically.
- This appliance must only be serviced by an authorised person.
- To avoid any flare-ups, it is recommended that the drip tray be checked and emptied regularly. Contents of the drip tray may be very hot during cooking. If emptied during extended cooking extreme caution should be taken and direct contact by hand should be avoided at all times. Allow to cool completely before disposing of the contents.

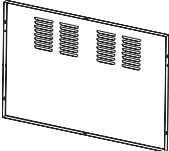
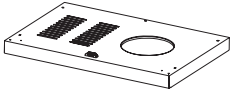
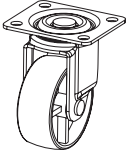
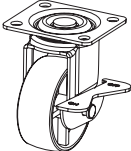
BQ1070F - EXPLODED DIAGRAM



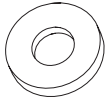

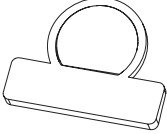
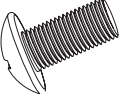



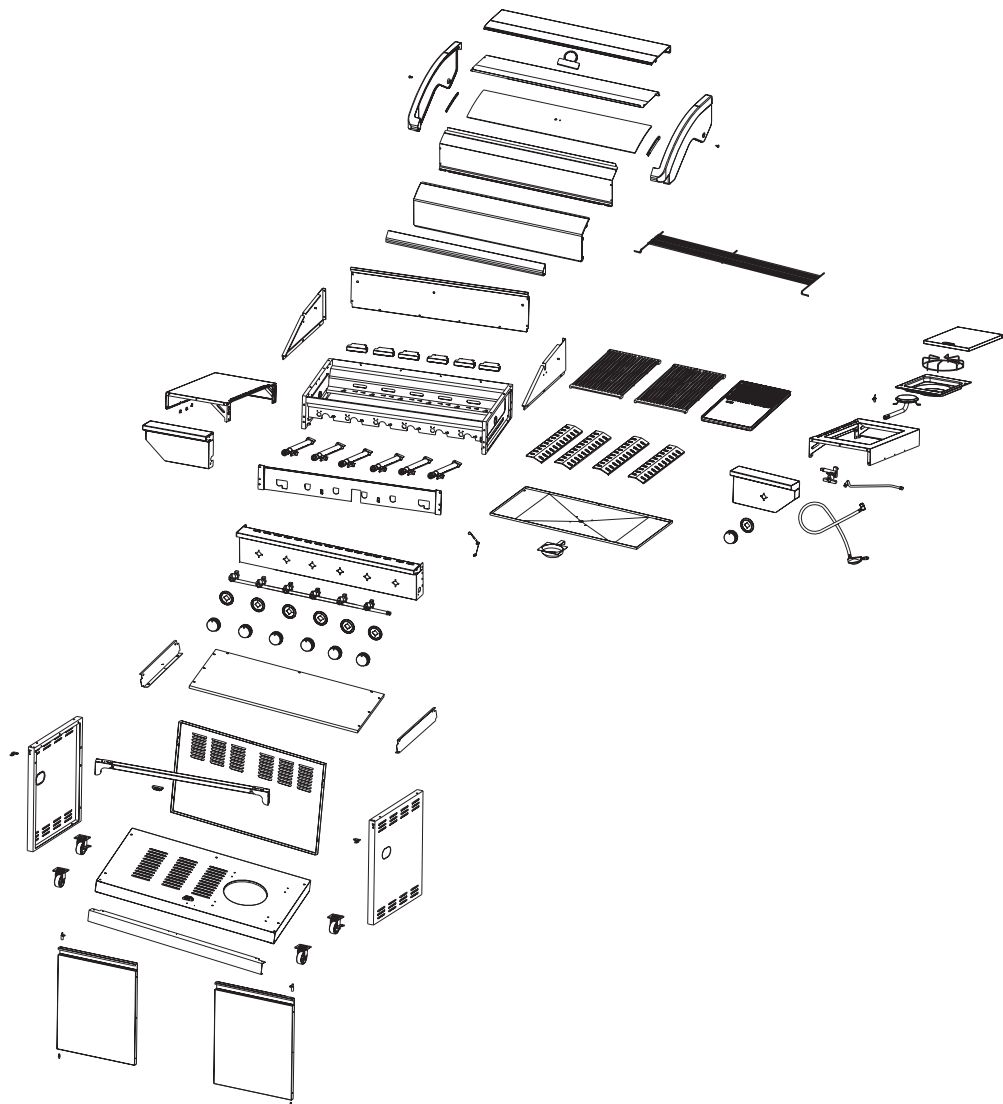



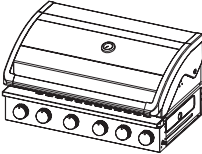

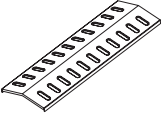

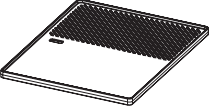
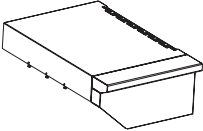
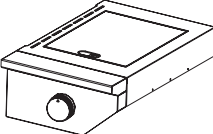
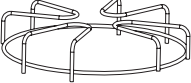
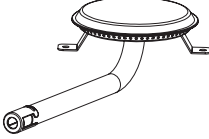
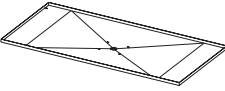
BQ1070F - PARTS LIST

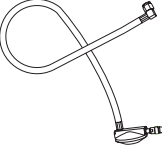
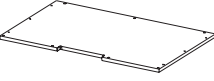
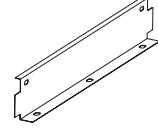
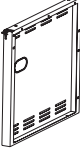
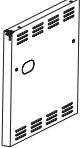
<p>1 Hood & Body Assy. x 1</p> 	<p>2 Warming Rack x 1</p> 	<p>3 Flame Tamer x 2</p> 	<p>4 Cooking Grill x 1</p> 
<p>5 Hot Plate x 1</p> 	<p>6 Side Shelf Assy. x 1</p> 	<p>7 Side Burner Assy. x 1</p> 	<p>8 Side Burner Grill x 1</p> 
<p>9 Side Burner x 1</p> 	<p>10 Drip Tray x 1</p> 	<p>11 Grease Cup x 1</p> 	<p>12 Regulator Assy. x 1</p> 
<p>13 Cabinet Top Panel x 1</p> 	<p>14 Cabinet Side Top Panel x 2</p> 	<p>15 Left Side Panel x 1</p> 	<p>16 Right Side Panel x 1</p> 
<p>17 Cabinet Beam Assy. x 1</p> 	<p>18 Cabinet Back Panel x 1</p> 	<p>19 Base Panel Assy x 1</p> 	<p>20 Castor without Lock x 2</p> 
<p>21 Castor with Lock x 2</p> 	<p>22 Left Door Assy. x 1</p> 	<p>23 Right Door Assy. x 1</p> 	<p>24 Match Holder x 1</p> 
<p>25 Washer-C (Ø6.4x14.5) x 4</p> 	<p>26 M5*10 Screw x 8</p> 	<p>27 Thermometer x 1</p> 	<p>28 M6*12 Screw x 46</p> 

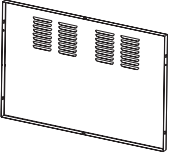
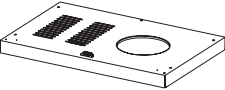
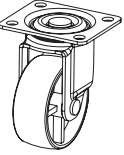
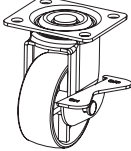
BQ1071F - EXPLODED DIAGRAM

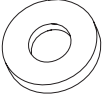

BQ1071F - PARTS LIST

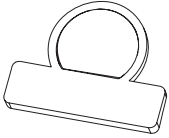
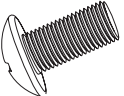
<p>1 Hood & Body Assy. x 1</p> 	<p>2 Warming Rack x 1</p> 	<p>3 Flame Tamer x 4</p> 	<p>4 Cooking Grill x 2</p> 
<p>5 Hot Plate x 1</p> 	<p>6 Side Shelf Assy. x 1</p> 	<p>7 Side Burner Assy. x 1</p> 	<p>8 Side Burner Grill x 1</p> 
<p>9 Side Burner x 1</p> 	<p>10 Drip Tray x 1</p> 	<p>11 Grease Cup x 1</p> 	<p>12 Regulator Assy. x 1</p> 
<p>13 Cabinet Top Panel x 1</p> 	<p>14 Cabinet Side Top Panel x 2</p> 	<p>15 Left Side Panel x 1</p> 	<p>16 Right Side Panel x 1</p> 
<p>17 Cabinet Beam Assy. x 1</p> 	<p>18 Cabinet Back Panel x 1</p> 	<p>19 Base Panel Assy x 1</p> 	<p>20 Castor without Lock x 2</p> 
<p>21 Castor with Lock x 2</p> 	<p>22 Left Door Assy. x 1</p> 	<p>23 Right Door Assy. x 1</p> 	<p>24 Match Holder x 1</p> 
<p>25 Washer-C (Ø6.4x14.5) x 4</p> 	<p>26 M5*10 Screw x 8</p> 	<p>27 Thermometer x 1</p> 	<p>28 M6*12 Screw x 46</p> 

ASSEMBLY INSTRUCTIONS

Note: The 4 burner model is shown here. Follow these instructions for 6 burner model also. Before assembling the barbecue, read these instructions carefully. Assemble the barbecue on a flat, clean surface. The barbecue is heavy.

Remove any transit protection material.

Tools Required: Phillips Head Screwdriver & Adjustable Spanner.

STEP 1

Use 16pcs M6*12 screw (28) to fix 2pcs swivel castor with lock (21) and 2pcs swivel castor without lock (20) under the base panel(19).

Note: Fit the locking Swivel castors at the rear of the base, so the locks can be accessed from the back of the Cart without the skirt panel being in the way.

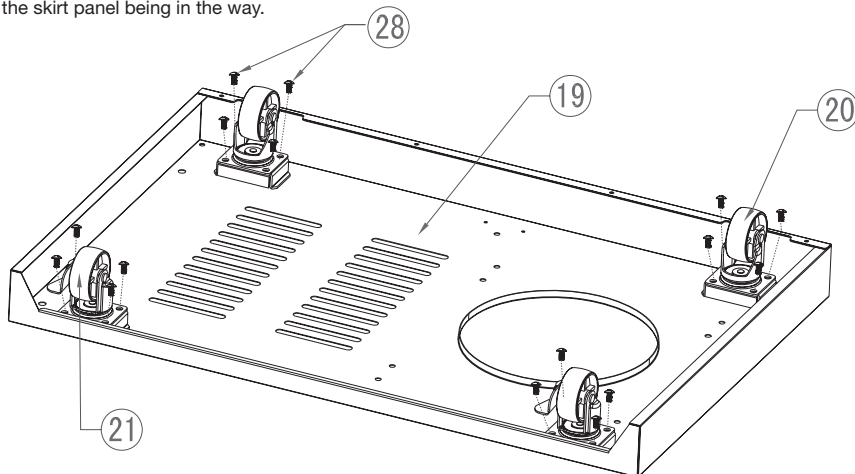

STEP 2

Use 4pcs M6*12 screw(28) to fix the cabinet left side panel(15) and cabinet right side panel(16) onto the base panel as shown.

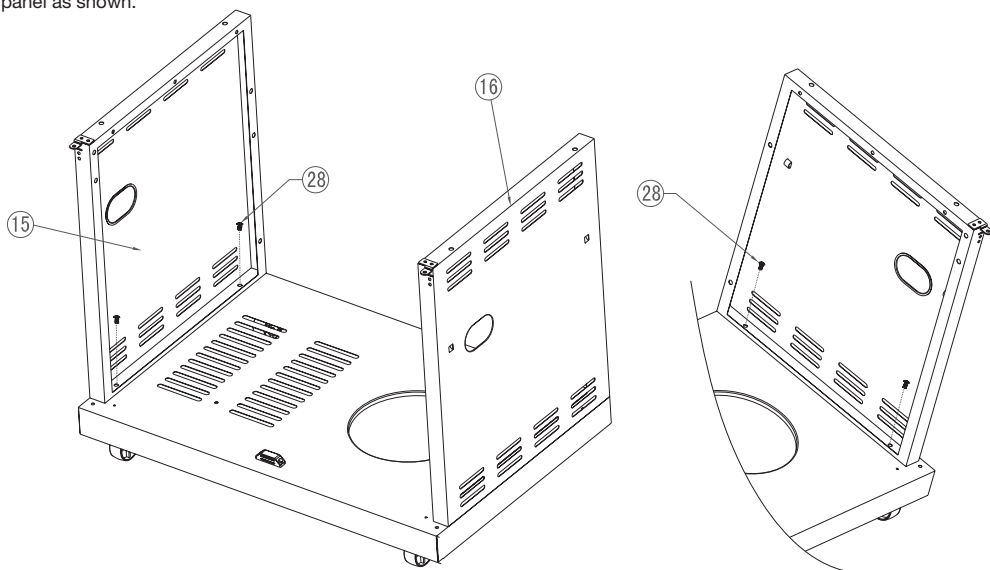

STEP 3

Use 5pcs M6*12 screw (28) to fix the back panel (18) onto base panel, cabinet left side panel and cabinet right side panel.

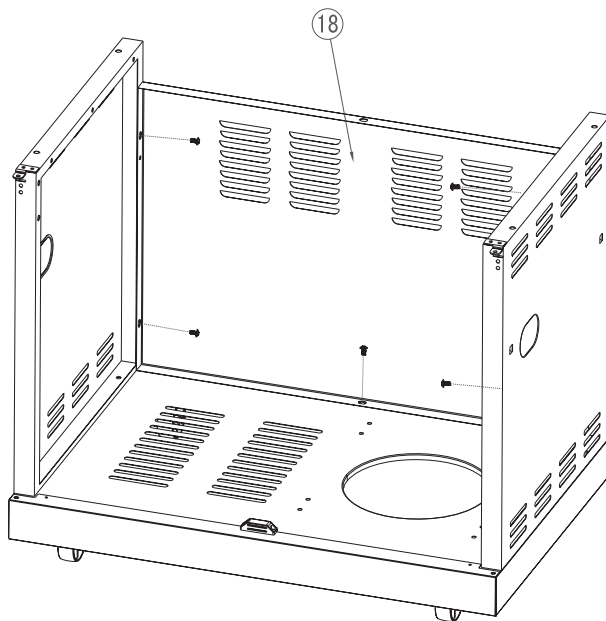

STEP 4

Use 4pcs M6*12 screw (28) to fix the cabinet beam assy (17) between two cabinet side panels, as shown.

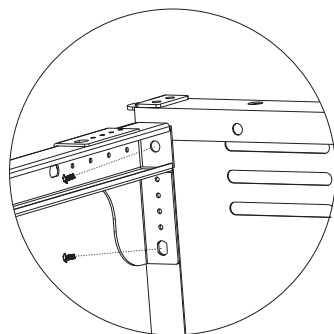
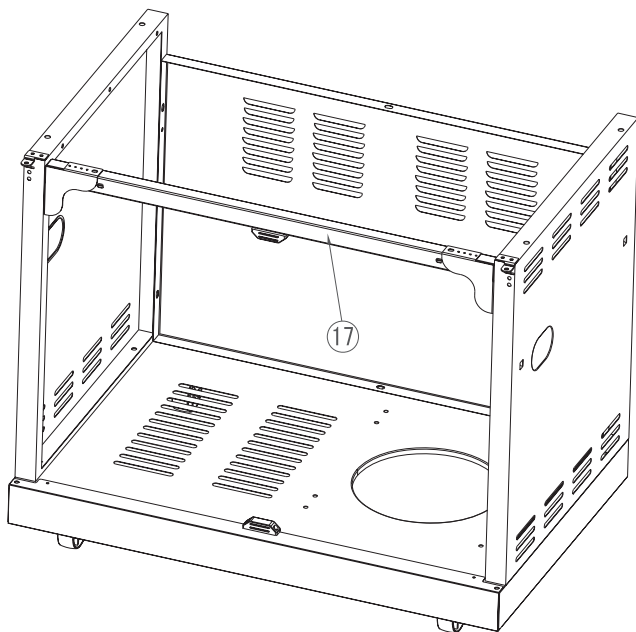

STEP 5

Use 9pcs M6*12 screw (28) to fix the cabinet top panel (13) onto cabinet side top panels (14) and back panel, then use 4pcs M5*10 screw (26) to fix the Cabinet Side Top Panel on cabinet side panels, as shown.

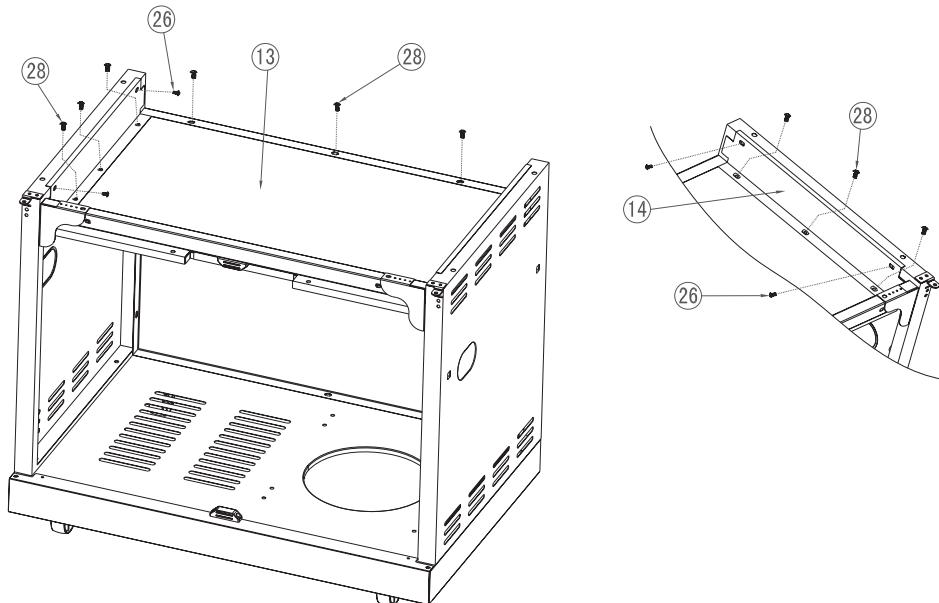

STEP 6

To fit the cabinet doors (22, 23), insert the fixed upper pin into the bracket as shown in the picture, then insert the bottom pin into the base panel, as shown.

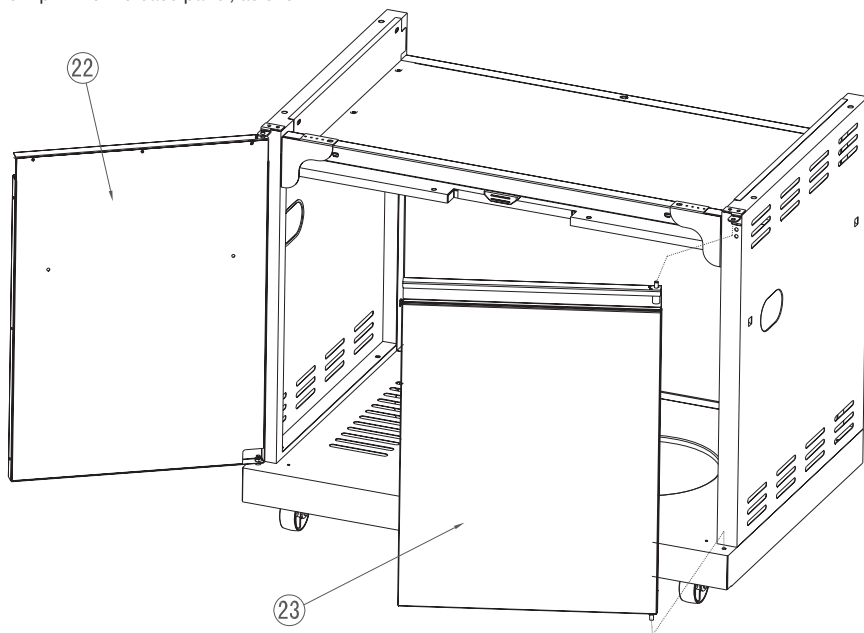

STEP 7

Rest the Hood & body assy (1) carefully onto the cabinet. Insert 4pcs M6*12 screw (28) through 4pcs washer-C (25) to fix the body assembly onto the cabinet as shown.

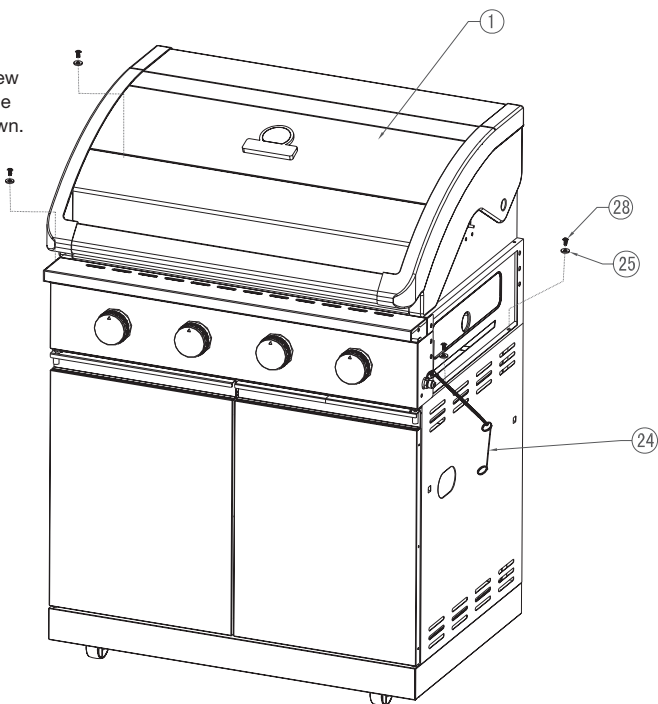

STEP 8

Loosen 2pcs preset M6*12 screw of left side shelf assy (6) by leaving about 5mm of thread exposed, hang the side shelf onto the screws and then tighten the screws. Use 2pcs M6*12 screw (28) fix the side shelf support onto the body, and use 2pcs M5*10 screw (26) to fix the side fascia to the end of BBQ control panel fascia, as shown.

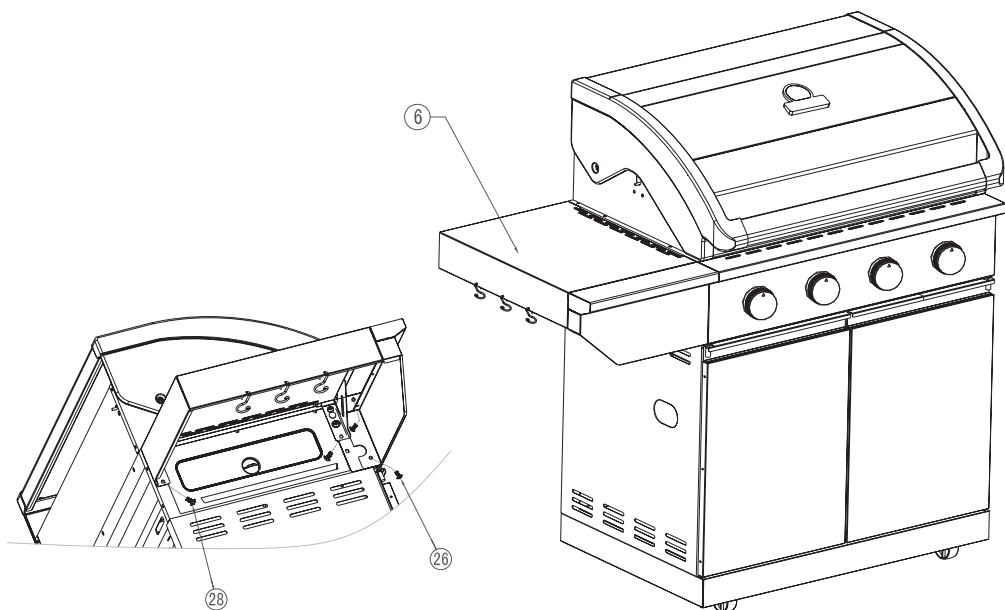

STEP 9.1

Loosen 2pcs preset M6*12 screw of right side burner assy (7) by leaving about 5mm of thread exposed, hang the side burner onto the screws and then tighten the screws. Use 2pcs M6*12 screw (28) fix the side burner support onto the body, and use 2pcs M5*10 screw (26) to fix the side fascia to the end of BBQ control panel fascia, as shown.

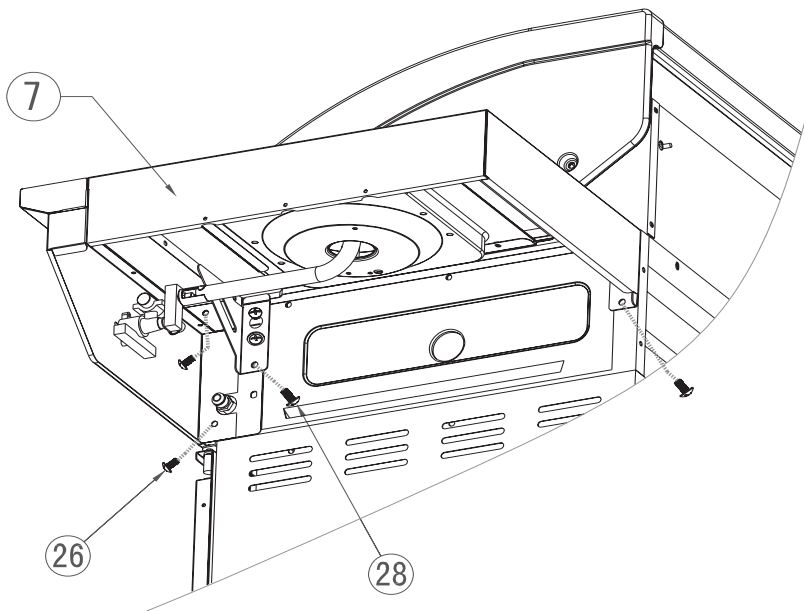

STEP 9.2

Connect the hose to manifold tightly, and put the regulator into cabinet through the hole on cabinet right panel, as shown.

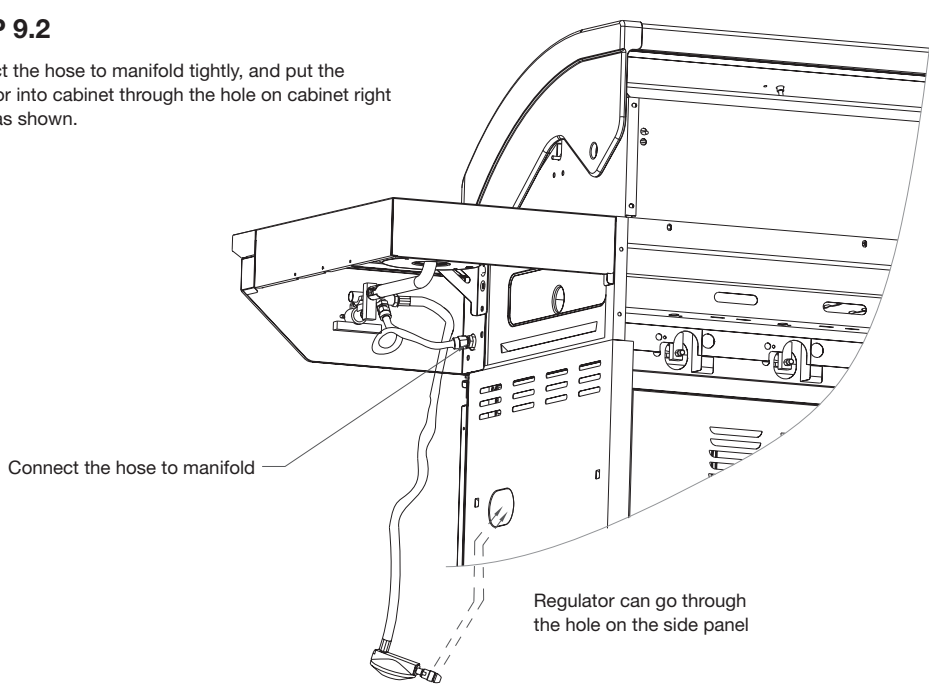

STEP 10

Place the grease cup (10) at bottom of drip tray (11) then insert into the slot at the back of BBQ.

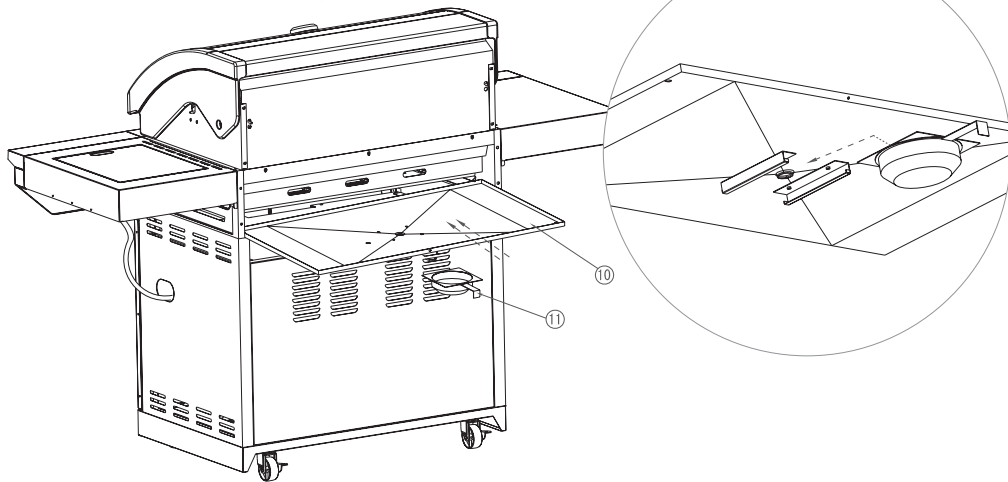

STEP 11

Place 2pcs of flamer tamer (3) on the top of left side 2 burners, and place the 1pc cooking grill (4) and hot plate (5) and warming rack (2) into the body assembly as shown in the picture.

Note: The cooking grill rests on top of the flamer tamer. 6 Burner model built with 2pcs of grills and 1pc of plate.

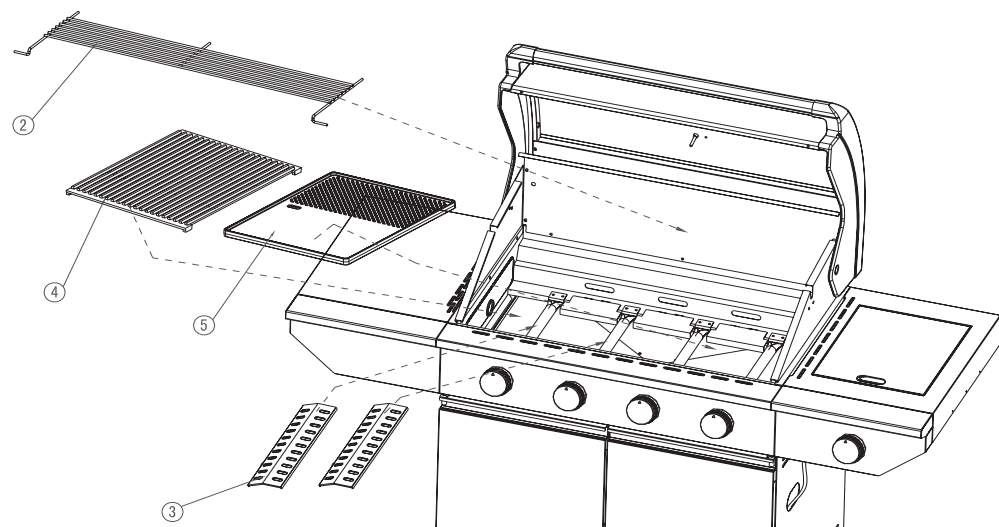
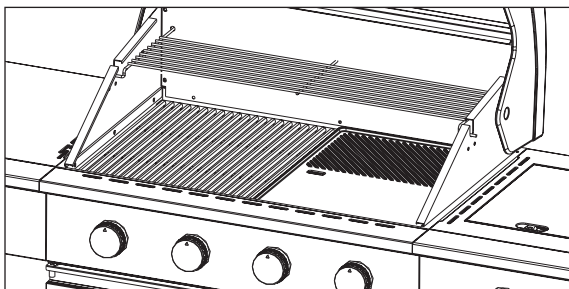

STEP 12

Open the cabinet door, and let the hose go through the cabinet side panel to connect to the cylinder. Open the cylinder valve and leak test all connections with a soapy water solution.

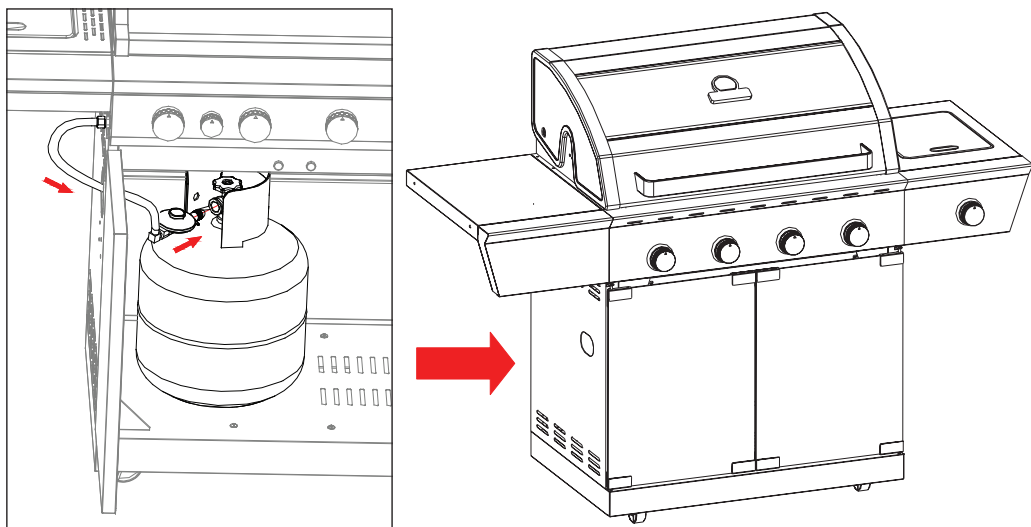

Note: 4B Shown

BBQ SPECIFICATIONS

Overall Barbecue Dimensions - Including Side Shelves

Model	Barbecue			Hood		
	Length	Width	Height	Length	Width	Height
4 Burner	1560mm	610mm	890mm	830mm	575mm	300mm
6 Burner	1730mm	610mm	890mm	1000mm	575mm	300mm

Nominal Hourly Gas Consumption

Gas Type	Number of BBQ Burners	Injector Size BBQ Burner	Injector Size Side Burner	Total Gas Consumption	Gas Pressure
ULPG	4	Ø 1.02mm	Ø 0.92mm	65.8 MJ/h	2.75 kPa
	6	Ø 1.02mm	Ø 0.92mm	93.2 MJ/h	2.75 kPa
	MJ/h each	13.7 MJ/h	11.0 MJ/h		
Natural Gas	4	Ø	Ø	MJ/h	1.0 kPa
	6	Ø	Ø	MJ/h	1.0 kPa
	MJ/h each	XX MJ/h	XX MJ/h		

GENERAL ASSEMBLY

CONNECTING & DISCONNECTING TO GAS SOURCE

Familiarise yourself with the general information and safety guidelines located at the front of this manual.

Check

1. Gas cylinder is filled. A sloshing sound will be heard when shaken.
2. The burner control is in the 'OFF' position.

Connecting

1. Ensure valve is in OFF position.
2. Check for any damage to the cylinder connection. NEVER attempt to use damaged equipment.
3. When connecting the hose to the cylinder tighten the nut to a positive stop by hand or spanner.
4. Open cylinder valve fully. If a leak can be heard at either end of the hose turn cylinder off and tighten joint. Wait 5 minutes before re-testing and use a soapy water solution to check the joint. If bubbles appear the connection will need to be re-tightened.

Disconnecting

1. Ensure the burner control is in the 'OFF' position.
2. Ensure the gas cylinder is in the full OFF position.
3. Detach the hose from cylinder.

LIGHTING PROCEDURE

Burner Operation & Ignition System Check

1. With cylinder valve in 'OFF' position push and rotate the control knobs. Check for sparking to the burners.
2. If spark is not evident at the burner ignition point, check for any loose leads at either the electrode or the gas valve.
3. Push and turn anti-clockwise to HIGH the control knob.
4. The side burner cover must be open before pushing and turning the control knob anti-clockwise to HIGH.
5. If the burner fails to light after several attempts turn off the gas supply and inspect for any obstructions to the gas flow.

If re-ignition is necessary while the gas barbecue is still hot, you must wait for a minimum of 5 minutes before commencing to re-ignite (this allows accumulated gas fumes to clear).



IMPORTANT

- **IMPORTANT:** Before connecting and disconnecting barbecue to gas source, make sure burner controls are in 'OFF' position.
- **CAUTION:** When the barbecue is not in use, the gas must be turned off at the cylinder.
- Check that the seals between the appliance and the gas cylinder are in place and in good condition before connecting the gas cylinder.
- Do not use this appliance if it has damaged or worn seals.
- **NOTE:** If for some reason, ignitor fails to produce a spark at the electrode, BBQ can be lit by a long BBQ match. With hood open insert ignited match into burner lighting hole positioned on the right hand side of the BBQ body (underneath side shelf). Push and turn the far right control knob to HIGH. Burner ignition can be checked through this hole. Subsequent burners will cross light.
- Check performance of burner prior to installing BBQ plates.
- Do not smoke when attempting to ignite BBQ.
- Never use volcanic rock, heat beads or other material.
- Always use protective gloves when handling hot components.

OPERATION

Burner Operation & Ignition System Check

Problem	Possible Reason	Solution
Burner will not ignite	Valve on gas bottle closed	Open valve on gas bottle
	Control knob is closed	Turn knob to high when lighting
	Igniter is faulty	Use a long barbecue match. Insert through the hole at side of barbecue
Food is not cooking or is taking too long	Burner has gone out	Check that the gas bottle is not empty and re-ignite the burner
	Cooking surface was not given enough time to warm up before the food was applied	Remove the food and give the burner time to warm the cooking surface (5-10 minutes)
	There is too much food on the cooking surface	Cook smaller portions

Note: If the appliance cannot be adjusted to perform correctly it should not be used until serviced or repaired.

OPERATING PROCEDURE

Preheating

It is necessary to preheat the barbecue for at least 5 minutes before cooking certain foods, depending on the type of food and the cooking temperature, your BBQ only needs a period of 2-3 minutes preheating.

Cooking Temperatures

HIGH setting - Use this setting only for fast warm up, for searing steaks and chops, and for burning food residue from the grill plates after cooking is over. Rarely, if ever, do you use the 'HIGH' setting for extended cooking.

MEDIUM setting (mid-way between 'HIGH' and 'LOW'). Use this setting for most grilling, and for cooking hamburgers and vegetables.

LOW setting - Use this setting when cooking very lean cuts such as fish. These temperatures vary with outside temperature and the amount of wind.

Roasting

For best results when roasting remove the hotplate and centre the grill. The outer two burners should be used on the low to medium setting.

Adjust the control knob to maintain the temperature around the medium mark (approx 200° to 230°).

Approximate Cooking Time

The table below shows approximate cooking times with the control set to 'MEDIUM' temperature.

Barbecue Roasts	Minutes (approx.)
Chicken & Rare Beef	45 minutes per Kg
Beef & Medium Lamb	60 minutes per Kg
Pork & Well Done Beef/Lamb	75 minutes per Kg



IMPORTANT

The side burner is designed for use with a wok or cooking pot up to 300mm in diameter.

Use of larger pots may result in discolouration of the finish.

The hood must be in the open position for lighting.

Do not smoke at any time when attempting to ignite the barbecue burners.

Do not leave the barbecue unattended when alight.

SAFE APPLIANCE LOCATIONS

This appliance shall only be used in an above ground open-air situation with natural ventilation, without stagnant areas, where gas leakage and products of combustion are rapidly dispersed by wind and natural convection.

Any enclosure in which the appliance is used shall comply with the following:

An enclosure with walls on all sides, but at least one permanent opening at ground level and no overhead cover.

Within a partial enclosure that includes an overhead cover and no more than two walls.

Within a partial enclosure that includes an overhead cover and more than two walls, the following will apply:

at least 25% of the total wall area is completely open, and

at least 30% of the remaining wall area is open and unrestricted.

In the case of balconies, at least 20% of the total wall area shall be and remain open and unrestricted.

DIAGRAMMATIC REPRESENTATIONS OF OUTDOOR AREAS

The following figures are diagrammatic representations of outdoor areas. Rectangular areas have been used in these figures – the same principles apply to any other shaped area.

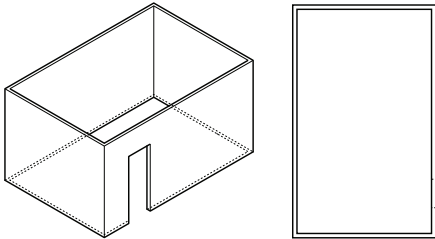

Outdoor Area - Example 1

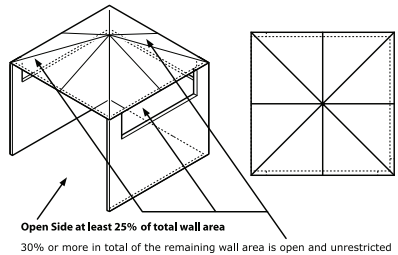

Outdoor Area - Example 4

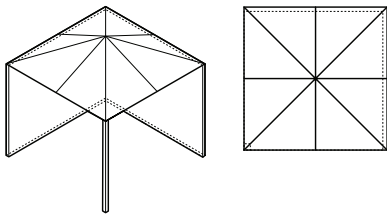

Outdoor Area - Example 2

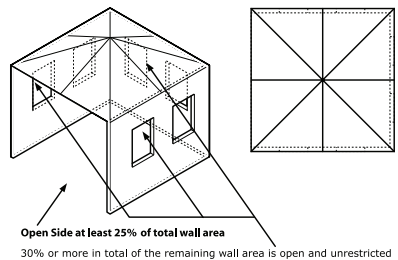

Outdoor Area - Example 5

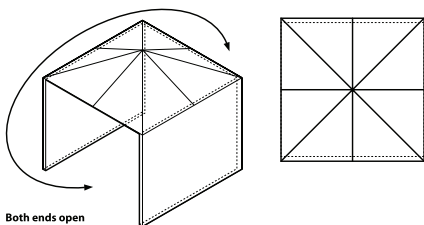

Both ends open

Outdoor Area - Example 3

For any queries or assistance call



Customer Service
(Australia Only)

1300 174 876

Hours of operation:
Monday to Friday 8am - 5pm EST

Do not return to place of purchase.
Keep your purchase receipt, this will be required to
make any claims under the 12 month warranty.

Gasmate®