

正面

型号：A7中英文说明书
 尺寸：单折90mm*90mm，共6折
 材质：80g书写纸，正反面
 工艺：黑白印刷

编码：GR-25-03-0001
 版本：A-0
 日期：20260322

刀模线

折痕线

出血线

留音伴睡音响 White Noise Sound Machine

A7



按键说明

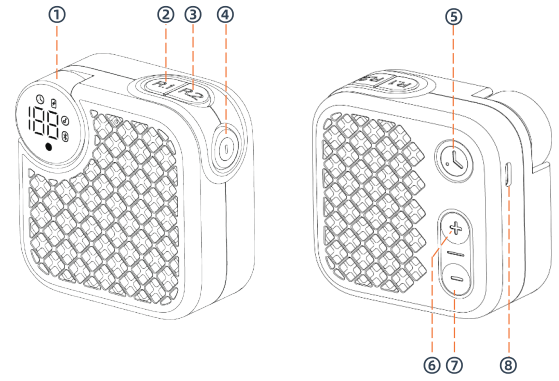

① 旋钮按键 (数显屏)	② 录音键 R1
③ 录音键 R2	④ 开关/模式键
⑤ 定时键	⑥ 上调键
⑦ 下调键	⑧ 充电口



按键	操作	功能
旋钮按键	短按	播放/暂停音频，定时时长确定
	长按	关闭数码管显示
录音键 R1 & R2	短按	播放相应按键的录音内容
	按住	按住2秒“嘟”一声后松手，开启录音
开关/模式键	短按	切换蓝牙模式/白噪音模式/录音模式
	长按	开/关机
定时键	短按	开启/关闭定时关机功能
	长按	进入定时关机时长设置
上调键	短按	增高音量
	长按	蓝牙模式下，切换下一曲
下调键	短按	降低音量
	长按	蓝牙模式下，切换上一曲

操作说明

长按【开关/模式键】开启/关闭设备；短按该按键切换蓝牙模式/白噪音模式/录音模式。

蓝牙模式

切换到蓝牙模式，【蓝牙图标】快速闪烁，自动进入搜索模式和回连模式。

1. 打开手机的蓝牙设置，搜索蓝牙名称：**A7**。

2. 配对连接成功后，即可使用。

● 当蓝牙配对连接成功时，【蓝牙图标】常亮。

● 当蓝牙连接丢失时，【蓝牙图标】快闪。

● 当有来电时，声音将自动切换回手机。

● 当蓝牙打开超过5分钟无配对连接时，将自动关闭蓝牙。

● 同时长按【上调键】和【下调键】，断开连接并清除当前配对。

● 蓝牙回连默认连接最后一台设备。

白噪音模式

切换到白噪音模式，【白噪音图标】亮显，实时显示当前曲目序号。

1. 顺时针旋转【旋钮按键】下一曲；逆时针旋转【旋钮按键】上一曲。

2. 短按【旋钮按键】可播放/暂停白噪音，暂停时数字显示“P”。

录音模式

切换到录音模式，绿色【录音指示灯】亮显。

1. 按住【录音键R1】或【录音键R2】2秒，在“嘟”一声后松手即可开始录入声音，显示屏开始计时时，录制完毕短按录音键即可保存录音。

2. 短按【录音键R1】或【录音键R2】播放对应录音键内容，【录音指示灯】慢闪，再次短按对应录音键退出播放；再次播放将从头开始播放。

3. 重复录制：当已存在录入内容时，重新录制将清除对应按键上的曲目。

音量调节

1. 音频播放时，短按【上调键】增高音量；短按【下调键】降低音量。

2. 开机默认音量为“08”，十六级音量，“00”为静音，“16”为最大声。

3. 音量调节时，显示屏会短暂显示当前音量等级。

充电设置

设备电量过低时，【电池图标】快闪提醒，应及时给设备充电。

● 充电时，【电池图标】常亮。

● 充满时，【电池图标】熄灭。

注意事项

本产品内置可充电锂电池，可循环使用；请使用配套的充电线将产品连接到普通的直流5V适配器进行充电。

● 工作温度：0°C-40°C

● 充电温度：0°C-40°C

● 首次使用前，建议先连接充电线充满电。

● 长期不使用，建议每三个月充满电一次。

● 请勿私自拆解、维修或改装本产品。

● 此设备部件不可替换，寿终时，应替换整个产品。



Button Instructions

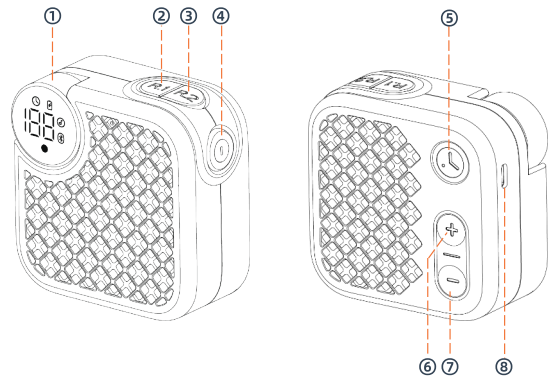

① Knob Button (Digital Display Screen)	② Record Button R1
③ Record Button R2	④ Power/Mode Button
⑤ Timer Button	⑥ UP Button
⑦ DOWN Button	⑧ Charging Port



Button	Operation	Functions
Knob Button	Press	Play/Pause audio. Confirm timer duration setting.
	Press & Hold	Turn off digital display screen.
Record Button R1 & R2	Rotate	Adjust white noise track or timer duration.
	Press	Play the recorded content of the button.
Power/Mode Button	Press & Hold	Press & hold for 2s, release after the "BEEP" to start recording.
	Press	Cycle through Bluetooth Mode, White Noise Mode and Recording Mode.
Timer Button	Press & Hold	Power ON/OFF
	Press	Turn on/off the timed shutdown function.
UP Button	Press & Hold	Enter the timed shutdown duration setting.
	Press	Volume Up
DOWN Button	Press & Hold	Next Track (Bluetooth Mode only)
	Press	Volume Down
DOWN Button	Press & Hold	Previous Track (Bluetooth Mode only)

Operation Instructions

Press & hold the **Power/Mode Button** to turn on/off the product.
 Press the **Power/Mode Button** once to cycle through **Bluetooth Mode**, **White Noise Mode** and **Recording Mode**.

Bluetooth Mode

Switch to Bluetooth Mode, the Bluetooth Icon flashes and the product starts Bluetooth searching and reconnecting.

1. Open the Bluetooth settings on your phone and search for "A7".

2. Bluetooth connection status.

● Bluetooth Icon stays lit: Paired.

● Bluetooth Icon flashes: Waiting for pairing.

● Incoming call: The audio will switch back to the phone automatically.

● Bluetooth will turn off automatically after 5 minutes if no any connection.

● Press and hold the UP Button and the DOWN Button at the same time, Bluetooth will disconnect and clear the current paired device.

● Bluetooth will automatically reconnect to the last device by default.

White Noise Mode

Switch to White Noise Mode, the White Noise Icon lights up, and the digital display shows the current white noise track number in real time.

1. Rotate the Knob Button clockwise for Next Track, rotate counterclockwise for Previous Track.

2. Press the Knob Button for Play or Pause. Digital display shows "P" when Pause.

Recording Mode

Switch to Recording Mode, the green Recording Indicator Light will stay on.

1. Press and hold any Record Button, R1 or R2 for 2 seconds, and release after the "BEEP" to start recording. The digital display will time the recording duration. Press the same Record Button again to finish recording and save.

2. Press any Record Button, R1 or R2 to play the content stored under the Button. The Recording Indicator Light flashes slowly. Press again to exit playback. Playback will start from the beginning when resumed.

3. Rerecord: If recording content already exists, rerecording will erase the track stored under the corresponding Record Button.

Volume Adjustment

1. When playing audio, press UP Button for volume up, DOWN Button for volume down.

2. There are 16 volume levels. "00" is Mute, "16" is Maximum. The default volume on power-up is "08".

3. When adjusting volume, the digital display briefly shows the current volume level.

Charging Setting

When battery is low, the Battery Icon flashes rapidly as a reminder. The device should be charged promptly.

● Battery Icon stays lit: Charging.

● Battery Icon off: Fully charged.

Precautions

This product contains a built-in rechargeable Li-Polymer battery. Please use the included charging cable to connect the product to a standard 5V DC adapter for charging.

● Working Temperature: 0°C-40°C

● Charging Temperature: 0°C-40°C

● Before first use, it is recommended to fully charge the device by connecting the charging cable.

● If the product is not used for a long time, it is recommended to fully charge it once every 3 months.

● Do not disassemble, repair, or modify this product without authorization.

● The components of this device are non-replaceable. At the end of its service life, the entire product should be replaced.

FCC Statement

This device complies with Part 15 of the FCC Rules. Operation is subject to the following two conditions:

(1) This device may not cause harmful interference, and

(2) This device must accept any interference received, including interference that may cause undesired operation.

The device has been evaluated to meet general RF exposure requirement. The device can be used in portable exposure condition without restriction.

Note: This equipment has been tested and found to comply with the limits for a Class B digital device, pursuant to Part 15 of the FCC Rules. These limits are designed to provide reasonable protection against harmful interference in a residential installation. This equipment generates, uses and can radiate radio frequency energy and, if not installed and used in accordance with the instructions, may cause harmful interference to radio communications.

However, there is no guarantee that interference will not occur in a particular installation. If this equipment does cause harmful interference to radio or television reception, which can be determined by turning the equipment off and on, the user is encouraged to try to correct the interference by one or more of the following measures:

- Reorient or relocate the receiving antenna.

- Increase the separation between the equipment and receiver.

- Connect the equipment into an outlet on a circuit different from that to which the receiver is connected.

- Consult the dealer or an experienced radio/TV technician for help.

Any Changes or modifications not expressly approved by the party responsible for compliance could void the user's authority to operate the equipment.

背面

