

# *PowerAirFryer* **Oven**<sup>TM</sup>



## **Owner's Manual**

Save These Instructions - For Household Use Only

MODEL: CM001

When using electrical appliances, basic safety precautions should always be followed. Do not use The **Power AirFryer Oven**<sup>TM</sup> until you have read this manual thoroughly.

Warranty Information Inside



# AirFryer, Rotisserie, Dehydrator & More

---

*The Power AirFryer Oven™ is the first all-in-one unit that air-fries, roasts, grills and bakes all you favorite foods with little or no oil.*



---

## Before You Begin

It is very important that you read this entire manual, making certain that you are totally familiar with its operation and precautions.

---

## The Power AirFryer Oven

Not only cooks your favorite fried foods, but also broils and bakes many other favorites like “air fried” burgers, calzones, and doughnuts. It couldn’t be easier, 8 “one touch presets” set the time and temperature for some of your favorites like crispy shrimp, fries and southern style chicken. Plus a Rotisserie and a Dehydrator preset that preserves fresh fruits and other foods for future use.

You and your family will enjoy many years of great tasting food and snacks with The **Power AirFryer Oven™**.

## We All Love Fried Food

Crispy fried chicken, French fries, coconut shrimp, chicken Parmesan, spicy hot wings, the list goes on and on. Those tasty delights have become part of our every day diet. Until now, it was impossible to get that great, crispy-fried crunch and flavor without frying in deep fat or oil.

## Good News!

The **Power AirFryer Oven™** has changed everything. Our culinary design team has perfected a cooking system that virtually eliminates the oil from the process. Messy, unhealthy oil is replaced with Turbo Cyclonic Air that surrounds your food, cooking it to crisp and juicy perfection.

# Table of Contents

---

<i><b>IMPORTANT SAFEGUARDS</b></i>	<b>4</b>
<i><b>Parts &amp; Accessories</b></i>	<b>6</b>
<i><b>Using the Accessories</b></i>	<b>8</b>
<i><b>Using the Digital Control Panel</b></i>	<b>10</b>
<i><b>Cooking Presets</b></i>	<b>11</b>
<i><b>General Operating Instructions</b></i>	<b>12</b>
<i><b>Cooking Chart</b></i>	<b>14</b>
<i><b>Cleaning &amp; Storage</b></i>	<b>15</b>
<i><b>Troubleshooting</b></i>	<b>15</b>
<i><b>Frequently Asked Questions</b></i>	<b>16</b>
<i><b>Warranty</b></i>	<b>17</b>



# IMPORTANT SAFEGUARDS

---

When using electrical appliances, basic safety precautions should always be followed, including:

- **NEVER IMMERGE** the Main Unit Housing, which contains electrical components and heating elements, in water. Do not rinse under the tap.
- **TO AVOID ELECTRICAL SHOCK, DO NOT** put liquid of any kind into the Main Unit Housing containing the electrical components.
- This appliance has a polarized plug (one blade is wider than the other). To **REDUCE THE RISK OF ELECTRIC SHOCK**, this plug is intended to fit into a polarized outlet only one way. If the plug does not fit fully into the outlet, reverse the plug. If it still does not fit, contact a qualified electrician. **DO NOT ATTEMPT** to modify the plug in any way.
- **MAKE SURE** the appliance is plugged into a wall socket. Always make sure that the plug is inserted into the wall socket properly.
- To prevent food contact with the interior upper screen and heat element, **DO NOT OVERFILL** the Rotating Mesh Basket.
- **DO NOT COVER** the Air Intake Vent or Air Outlet Vent while the **Power AirFryer Oven** is operating. Doing so will prevent even cooking and may damage the Unit or cause it to overheat.
- **NEVER POUR** oil into the Rotating Mesh Basket. Fire and personal injury could result.
- While cooking, the internal temperature of the Unit reaches several hundred degrees Fahrenheit. **TO AVOID PERSONAL INJURY**, never place hands inside the Unit unless it is thoroughly cooled down.
- This appliance is **NOT INTENDED FOR USE** by persons with reduced physical, sensory, or mental capabilities, or lack of experience and knowledge, unless they are **UNDER THE SUPERVISION** of a responsible person or have been given proper instruction in using the appliance. This appliance is **NOT INTENDED FOR USE** by children.
- When cooking, **DO NOT PLACE** the appliance against a wall or against other appliances. Leave at least 5” free space on the back and sides and above the appliance. Do not place anything on top of the appliance.
- **DO NOT USE** this Unit if the plug, the power cord, or the appliance itself is damaged in any way.
- **DO NOT PLACE** The Unit on stovetop surfaces.
- If the power cord is damaged, **YOU MUST HAVE IT REPLACED** by the manufacturer, its service agent, or a similarly qualified person in order to avoid hazard.
- Keep the appliance and its power cord **OUT OF THE REACH** of children when it is in operation or in the “cooling down” process.
- **KEEP THE POWER CORD AWAY** from hot surfaces. **DO NOT PLUG** in the power cord or operate the Unit controls with wet hands.
- **NEVER CONNECT** this appliance to an external timer switch or separate remote-control system.
- **NEVER USE** this appliance with an extension cord of any kind.
- **DO NOT OPERATE** the appliance on or near combustible materials such as tablecloths and curtains.
- **DO NOT USE** the **Power AirFryer Oven** for any purpose other than described in this manual.
- **NEVER OPERATE** the appliance unattended.
- When in operation, air is released through the Air Outlet Vent. **KEEP YOUR HANDS AND FACE** at a safe distance from the Air Outlet Vent. Also avoid the air while removing the Rotating Mesh Basket from the appliance.



# IMPORTANT SAFEGUARDS

---

- The Unit's outer surfaces may become hot during use. The Rotating Mesh Basket **WILL BE HOT**. **WEAR OVEN MITTS**, or use the fetch tool when handling hot components. Wear oven mitts when handling hot surfaces.
- Should the Unit emit black smoke, **UNPLUG IMMEDIATELY** and wait for smoking to stop before removing oven contents.
- When time has run out, cooking will stop but the fan **WILL CONTINUE RUNNING** for 20 seconds to "cool down" the Unit.
- Always operate the appliance on a horizontal surface that is level, stable, and noncombustible.
- This appliance is intended for normal household use only. It is not intended for use in commercial or retail environments.
- If the **Power AirFryer Oven** is used improperly or for professional or semi-professional purposes or if it is not used according to the instructions in the user manual, the warranty becomes invalid and we will not be held liable for damages.
- Always unplug the appliance after use.
- Let the appliance cool down for approximately 30 minutes before handling, cleaning, or storing.
- Make sure the ingredients prepared in this Unit come out cooked to a golden-yellow color rather than dark or brown. Remove burnt remnants.

## Overheating Protection

Should the inner temperature control system fail, the overheating protection system will be activated and the Unit will not function. Should this happen, unplug the power cord. Allow time for the Unit to cool completely before restarting or storing.

## Automatic Shut-Off

The appliance has a built in "shut-off" device, that will automatically shut down the unit when the Timer LED reaches zero. You can manually switch off the appliance by selecting the Power Button. The fan will continue running for 20 seconds to "cool down" the unit.

## Electric Power

If the electrical circuit is overloaded with other appliances, your new Unit may not operate properly. It should be operated on a dedicated electrical circuit.

## Electromagnetic Fields (EMF)

This appliance complies with all standards regarding electromagnetic fields (EMF). If handled properly and according to the instructions in this user manual, the appliance is safe to use based on scientific evidence available today.

---

**SAVE THESE INSTRUCTIONS - FOR HOUSEHOLD USE ONLY.**

# Parts & Accessories

**NOTE:** Unpack all listed contents from packaging. Varies by model. Please remove any clear or blue protective film on the components.

- |                         |                                   |   |
|-------------------------|-----------------------------------|---|
| 1. Main Unit            | 6. Rotating Mesh Basket           | 9. Rotisserie Shaft, Forks & Set Screws |
| 2. Control Panel        | 7. Drip Tray                      | 10. Rotisserie Fetch Tool               |
| 3. Air Intake Vents     | 8a*. Skewers (10)                 | 11. Rotisserie Stand                    |
| 4. Hot Air Outlet Vents | 8b*. Adjustable Skewers Racks (2) |   |
| 5. Air Flow Racks       |                                   |   |



Based on model quantity may vary.

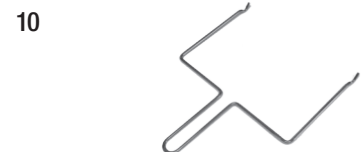
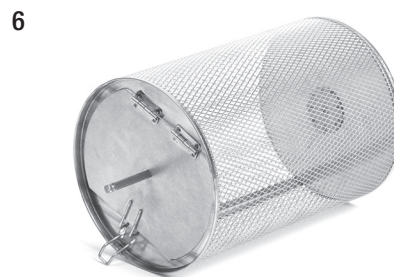

# Parts & Accessories

---

## 5. Air Flow Racks

Can be used not only for dehydration but also to cook crispy snacks or reheat items like pizza.

## 6. Rotating Mesh Basket

Great for fries, roasting nuts and other snacks. Use Rotisserie Fetch Tool to place basket into Unit.

## 7. Drip Tray

Cook with the Drip Pan in place for easy clean ups.

## 8a. Skewers (\*Optional)

Great for all your kabob recipes, meat, fish or veggies.

## 8b. Adjustable Skewer Racks (\*Optional)

Used when making kabobs. Skewer Racks fit over Shaft and lock in place with Set Screws.

## 9. Rotisserie Shaft, Forks & Set Screws

Use for roasts and whole chicken. Force shaft lengthwise through meat and center. Slide forks onto shaft from either end into meat, then lock in place with set screws. There are indentations on the shaft for the set screws. You can adjust the screws closer to the middle if needed but never but never outward towards the ends. **NOTE:** Make sure roast or chicken is not too large to rotate freely within the oven. Maximum Chicken or Roast, 3.5-4 lb.

## 10. Rotisserie Fetch Tool

Use to remove cooked roasts and chicken that have been prepared using the rotisserie or skewer methods. Place under Rotisserie Shaft and lift, left side first then gently extract the food.

## 11. Rotisserie Stand (\*Optional)

Use for placing the Rotisserie Shaft when removing hot food from the Unit.

## Important

Please make sure that your **Power AirFryer Oven** has been shipped with the components that you ordered (as some accessories may be sold separately). Check everything carefully before use. If any part is missing or damaged, do not use this product. Contact shipper using the customer service number located in the back of the owner's manual. **NOTE:** Some accessories may not be included with the purchase.

---

## Warning

Forks, Skewers and other metal parts with this unit are sharp and will get extremely hot during use. Great care should be taken to avoid personal injury. Wear protective oven mitts or gloves.

# Unit Specifications

Model Number	Supply Power	Rated Power	Function	Temperature	Display
CM001	AC 120V 60Hz	1700W	Rotation	150° F - 400° F (165° C - 200° C)	LED Touch Screen



# Using the Accessories

## Place Air Flow Racks into Unit

1. Insert Drip Tray into bottom of the Unit.
2. Place Air Flow Racks into Unit by sliding through the side grooves and onto the back lip (fig. A).
3. Place Air Flow Racks closer to the top heating element for faster cooking and added crisp (fig. B).
4. Rotate the Air Flow Racks mid-cycle for even cooking.

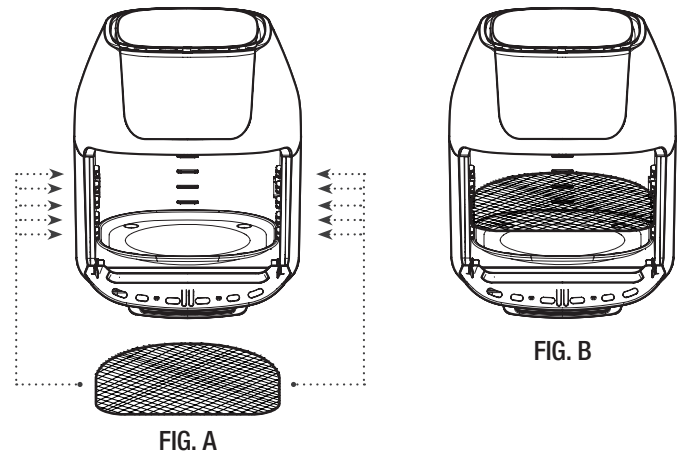

## Components

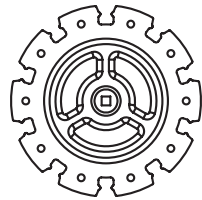

SKEWER RACK (x2)  
FRONTAL VIEW

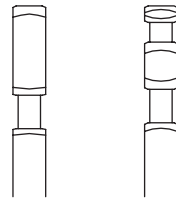

ROTISSERIE SHAFT  
LEFT SIDE    RIGHT SIDE



SKEWERS  
(x10)



SET SCREWS  
(x2)

## Rotisserie Shaft & Skewers Racks

1. Place the two Skewer Racks at each end of the Rotisserie Shaft. Make sure the Set Screws are on the outer side of the Rotisserie Shaft.
2. Slightly tighten Set Screws. Do not over tighten as you may need to adjust the tightness after you insert the Skewers.
3. Carefully poke Skewers through food.

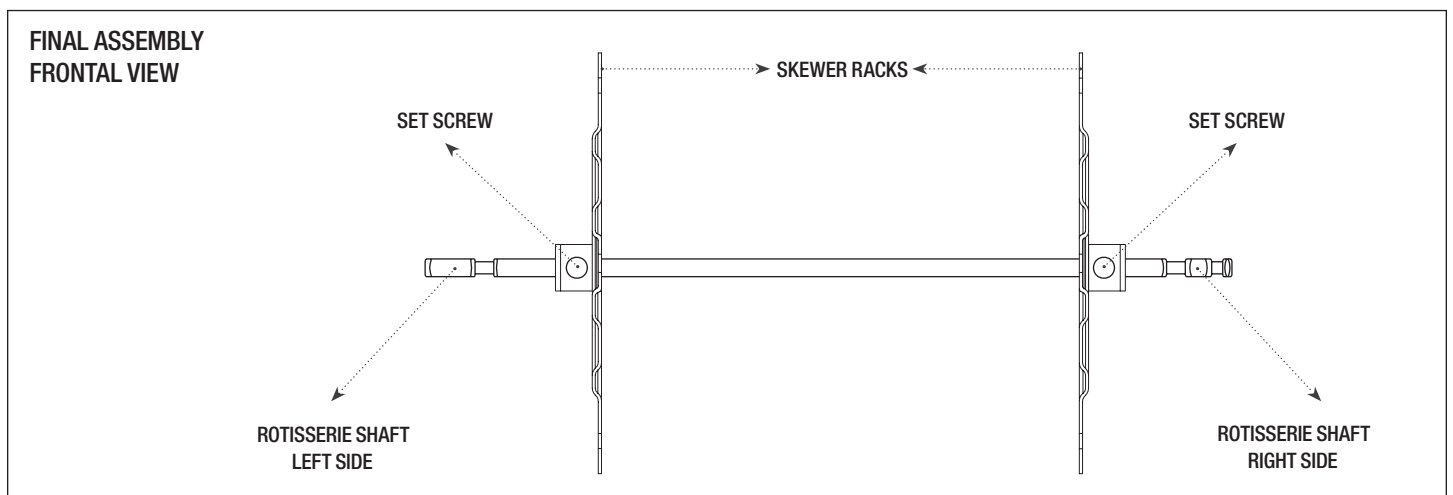

# Using the Accessories

## Rotisserie Spit Assembly

1. Insert each Skewer point through holes on the left Skewer Rack (fig. C).
2. Squeeze the clip-end of each Skewer as you insert into the opposite Skewer Rack slot to secure.
3. Release clip to securely rest in slot as shown (fig. D).
4. Repeat process 3 through 6 in a uniform manner around the Skewer Rack. Make sure Skewers are evenly spaced.
5. Tighten the Set Screws to make sure they are securely in place.
6. Use caution while inserting the Spit into the Unit to prevent getting poked by the Skewer ends.

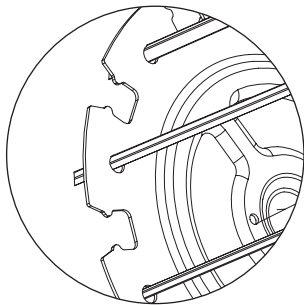
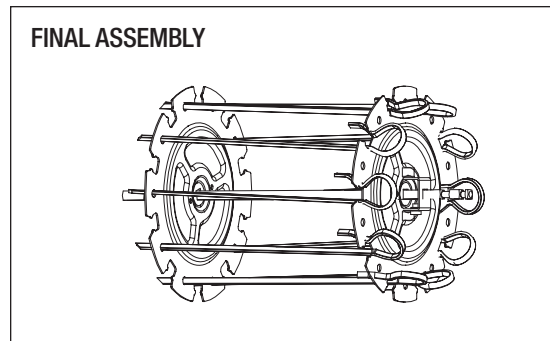

FIG. C - LEFT SIDE



FINAL ASSEMBLY

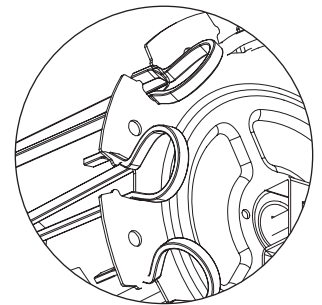

FIG. D - RIGHT SIDE

## Place Rotisserie Spit or Rotating Mesh Basket into Unit

1. Insert the left side of the assembled Spit or Basket first into the Rotisserie Shaft socket. Be sure the Rotisserie Shaft is in place to engage rotation (fig. E).
2. Place the right side onto the hanger (fig. F).

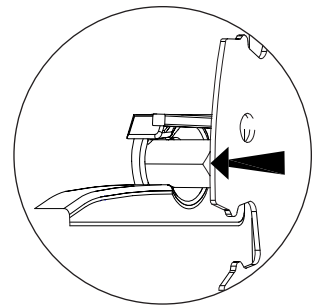
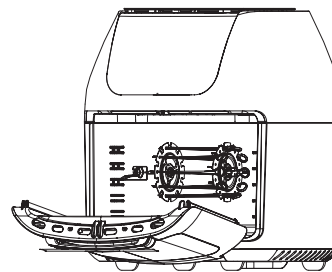

FIG. E - LEFT SIDE

## Remove Rotisserie Spit or Rotating Basket from Unit

1. Open Unit door to pause cooking cycle or turn Unit off by pressing the Power Button.
2. Insert Rotisserie Fetch tool beneath the Rotisserie Shaft.
3. Lift the right side of the Rotisserie Fetch tool at a slight angle to clear the bracket, then shift to the right until the left side of the Shaft slides out of the Rotisserie Shaft socket.
4. Carefully remove the rotisserie food from the oven.

**IMPORTANT:** See the Final Assembly diagram (page 8) to help identify the left and right sides of the Rotisserie Shaft before placing it in the Unit. The right side has two notches, and the left has one.

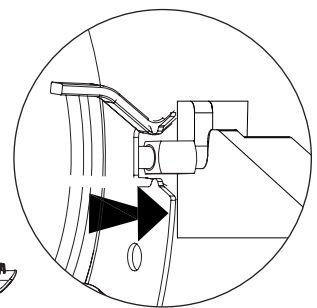
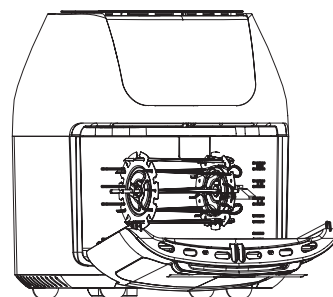
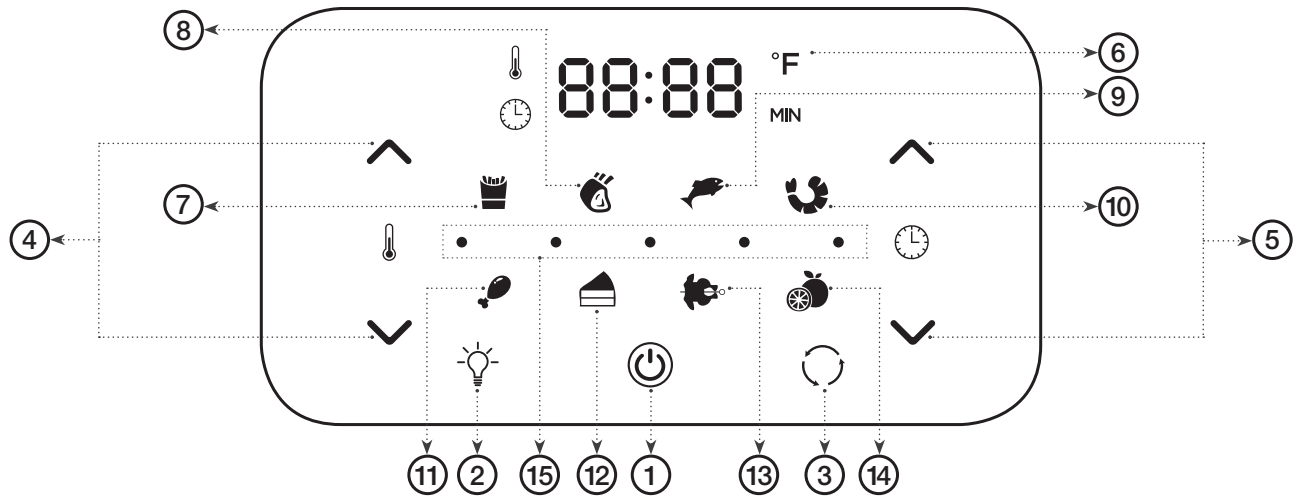

FIG. F - RIGHT SIDE

# Using the Digital Control Panel



**1. Power/Start-Stop Button** - Once unit is plugged in, the Power Button will light up. Selecting the Power Button once will cause the full panel to be illuminated. Selecting the Power Button a second time will activate the cooking process at the default temperature of 370° F (190° C) and time of 15 minutes. Selecting the Power Button at any time during the cooking process will shut down the Unit causing display to go dark immediately and running light to go dark within 20 seconds. The fan will continue running for 20 seconds to “cool down” the Unit.

**2. Internal Light** - Selecting this button will help you check cooking progress while Unit is in operation. **NOTE:** Opening the door during the cooking process will pause the Unit. Internal light will illuminate if doors open.

**3. Rotation Button** - Select this button when cooking anything using the Rotisserie Mode. Function can be used with any preset. The icon will blink while in use.

**4. Temperature Control Buttons** - These buttons enable you to raise or lower cooking temperature by 5° F (2.7° C) intervals starting from 150° F (65° C) to 400° F (200° C). Dehydration is from 90° F (30° C) to 170° F (75° C).

**5. Time Control Buttons** - These buttons enable you to select exact cooking time to the minute, from 1 to 60 minutes in all modes except when dehydrating, which uses 30 minute intervals and an operating time from 2 to 24 hours.

**6. LED Digital Display** - The Digital Numeric Display will switch between Temperature and Time Remaining during the cooking process.

**7 - 14. Cooking Presets** - Selecting any of these will set Time and Temperature to a default setting for that particular food. You may over-ride these presets with Time and Temperature Buttons. View presets on the next page.

**15. Running Lights** - These lights will blink in sequence while cooking is in progress and continue blinking up to 20 seconds once you shut Unit down.

# Cooking Presets

## Preset Button Cooking Chart

\* Cooking time for whole roasted chicken will vary with weight. Use meat thermometer to check internal temperature as per chart below.

Preset Button	Temperature	Time
7. French Fries	400° F (200° C)	15 mins.
8. Steaks/Chops	370° F (185° C)	25 mins.
9. Fish	390° F (200° C)	15 mins.
10. Shrimp	320° F (160° C)	12 mins.
11. Chicken	370° F (185° C)	40 mins.
12. Baking	350° F (175° C)	30 mins.
13. Rotisserie	400° F (200° C)	30 mins.*
14. Dehydrator*	90° F (30° C)	4 hrs. (*2-24 hrs.)

## Using the Power AirFryer Oven Without Presets

Once you are familiar with the **Power AirFryer Oven** you may want to experiment with your own.

## Warning

Never use a cooking vessel filled with cooking oil or any other liquid with this unit! Fire hazard or personal injury could result.

## Internal Temperature Meat Chart

This chart should be used to check the internal temperature for cooked meats. USDA Food Safety Standards.

Food	Type	Internal Temperature
Beef & Veal	Ground	160° F (70° C)
	Steaks, roasts-medium	160° F (70° C)
	Steaks, roasts-rare	145° F (63° C)
Chicken & Turkey	Breasts	165° F (75° C)
	Ground, stuffed	165° F (75° C)
	Whole bird, legs, thighs, wings	165° F (75° C)
Fish & Shellfish	Any type	145° F (63° C)
Lamb	Ground	160° F (70° C)
	Steaks, roasts-medium	160° F (70° C)
	Steaks, roasts-rare	145° F (63° C)
Pork	Chops, ground, ribs, roasts	160° F (70° C)
	Fully cooked ham	140° F (60° C)

# General Operating Instructions

---

## Before using the Power AirFryer Oven for the first time

---

1. Read all material and warning stickers and labels.
2. Remove all packing materials, labels and stickers.
3. Wash all parts and accessories used in the cooking process with warm soapy water. **NOTE:** Only the accessories are dishwasher safe.
4. Wipe the inside and outside of the cooking Unit with a clean moist cloth.

**NOTE:** Never wash or submerge the cooking Unit in water.

**NOTE:** When using this unit, never fill any cooking vessel with oil or liquid of any kind. This Unit cooks with hot air only.

---

## Preparing for Use

1. Place the appliance on a stable, level, horizontal and heat resistant surface.
2. Select the cooking accessory for your recipe.

## A Versatile Appliance

The **Power AirFryer Oven** is designed to cook a wide variety of your favorite foods. The charts and tables provided within this manual and the Recipe Guide will help you get great results. Please refer to this information for proper time / temperature settings and proper food quantities.

## Warning

- **NEVER** put anything on top of the appliance.
- **NEVER** cover the air vents on the top and back of the cooking Unit.
- **NEVER** fill any cooking vessel with oil or liquid of any kind. This Unit cooks with hot air only.
- **NEVER** use the Oven Door as a place to rest a hot Fry Basket filled with food. The Hot Fry Basket could damage the Oven Door or cause the Unit to tip. Personal injury could result.
- **ALWAYS** use oven mitts when removing hot Air Flow Racks.

# General Operating Instructions

## Cooking with the Power AirFryer Oven

1. Place the ingredients on an Air Flow Rack, one of the Rotisserie accessories, or in the Rotating Mesh Basket.
2. Put the Air Flow Rack, Rotating Mesh Basket or Rotisserie Spit, into the unit and shut the oven door. Plug the power cord into the 110V, dedicated outlet.
3. When Rotating Mesh Basket or Rotisserie and food is in place, Press the Power Button once (page 10, fig. 1).
4. Select a preset function (page 10, figs. 7-14) or manually set the Temperature and then the Time (page 10, figs. 4 and 5). Refer to the detailed Control Panel instructions on page 10.
5. If a preset function was selected, the Unit will automatically start the cooking cycle. On the other hand, if the Temperature and Time were set manually, you need to press the Power Button to begin the cooking cycle.

**NOTE:** You may open the oven door to view the rotisserie at any time during the process to check the progress.

**NOTE:** Consult the Charts in this manual or the Recipe Books to determine the correct settings.

## Tips

- Foods that are smaller in size usually require a slightly shorter cooking time than larger ones.
- Large quantities of food only require a slightly longer cooking time than smaller quantities.
- “Flipping” or turning smaller sized foods halfway through the cooking process, assures that all the pieces are evenly fried.
- Misting a bit of vegetable oil to fresh potatoes is suggested for a crispier result. When adding a little oil, do so just before cooking.
- Snacks normally cooked in an oven can also be cooked in the **Power AirFryer Oven**.
- Use pre-made dough to prepare filled snacks quickly and easily. Pre-made dough also requires a shorter cooking time than homemade dough.
- Place a baking tin or oven dish in the **Power AirFryer Oven** when baking a cake or quiche. A tin or dish is also suggested when cooking fragile or filled foods.
- You can use the **Power AirFryer Oven** to reheat foods. Simply set the temperature to 300° F (150° C) for up to 10 minutes.

## Important

### Removing Cooked or Hot Food

When removing cooked or hot food use the Rotisserie Fetch Tool (fig. A), or oven Mitts. Fetch Tool can also be used with Rotisserie Spit.

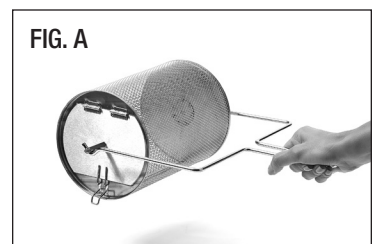

## Warning

- During the cooking process, the Rotating Mesh Basket and other accessories will become very hot. When you remove it to check on the progress, make sure you have a trivet or a heat resistant surface nearby to set it down on. **NEVER** place the Rotating Mesh Basket directly on a counter top or table.
- Cooking accessories will get hot during the air frying process. Wear oven mitts and handle with care to **AVOID INJURY**.

# Cooking Chart

Food Item	Min - Max	Time*	Temperature	Comments
Thin Frozen Fries	1 ¼ - 3 cups	15 - 16 min.	400° F (200° C)	
Thick Frozen Fries	1 ¼ - 3 cups	15 - 20 min.	400° F (200° C)	
Homemade Fries	1 ¼ - 3 ¼ cups	10 - 16 min.	400° F (200° C)	Add ½ tbsp. oil
Homemade Potato Wedges	1 ¼ - 3 ¼ cups	18 - 22 min.	360° F (182° C)	Add ½ tbsp. oil
Homemade Potato Cubes	1 ¼ - 3 cups	12 - 18 min.	360° F (182° C)	Add ½ tbsp. oil
Hash Browns	1 cup	15 - 18 min.	360° F (182° C)	
Potato Gratin	2 cup	15 - 18 min.	400° F (200° C)	
Steak	¼ - 1.1 lb.	8 - 12 min.	360° F (182° C)	
Pork Chops	¼ - 1.1 lb.	10 - 14 min.	360° F (182° C)	
Hamburger	¼ - 1.1 lb.	7 - 14 min.	360° F (182° C)	
Sausage Roll	¼ - 1.1 lb.	13 - 15 min.	400° F (200° C)	
Chicken Drumsticks	¼ - 1.1 lb.	18 - 22 min.	360° F (182° C)	
Chicken Breast	¼ - 1.1 lb.	10 - 15 min.	360° F (182° C)	
Spring Rolls	¼ - ¾ lb.	15 - 20 min.	400° F (200° C)	Use oven-ready
Frozen Chicken Nuggets	¼ - 1.1 lb.	10 - 15 min.	400° F (200° C)	Use oven-ready
Frozen Fish Sticks	¼ - 1.1 lb.	6 - 10 min.	400° F (200° C)	Use oven-ready
Mozzarella Sticks	¼ - 1.1 lb.	8 - 10 min.	360° F (182° C)	Use oven-ready
Stuffed Vegetables	¼ - 1.1 lb.	10 min.	320° F (160° C)	
Cake	1 ¼ cups	20 - 25 min.	320° F (160° C)	Use baking tin
Quiche	1 ½ cups	20 - 22 min.	360° F (182° C)	Use baking tin/oven dish
Muffins	1 ¼ cups	15 - 18 min.	400° F (200° C)	Use baking tin
Sweet Snacks	1 ½ cups	20 min.	320° F (160° C)	Use baking tin/oven dish
Frozen Onion Rings	1 lb.	15 min.	400° F (200° C)	

## Settings

This table will help you select the correct temperature and time for best results. As you become more familiar with the **Power AirFryer Oven** cooking process, you may adjust these settings to suite your own personal tastes.

The table above will help you choose the basic settings for the ingredients selected.

\*Add 3 minutes to cooking time when starting with a cold appliance.

**NOTE:** Keep in mind that these settings are indications. As ingredients differ in origin, size, shape and brand, we cannot guarantee the best settings for your ingredients.

## Tip

Set the Timer to ½ the time needed for the recipe and the Timer bell will alert you when it's time to "flip" your food. When you hear the timer bell, the pre-set preparation time has elapsed.

# Cleaning & Storage

## Cleaning

Clean the **Power AirFryer Oven** after each use. The Rotating Mesh Basket and other accessories are made of durable stainless steel and are dishwasher safe. Never use abrasive cleaning materials or utensils on these surfaces. Caked on food should be soaked for easy removal in warm soapy water.

1. Remove the power cord from the wall socket and be certain the appliance is thoroughly cooled before cleaning.
2. Wipe the outside of the appliance with a warm, moist cloth and mild detergent.
3. To clean the oven door, remove it by lifting it to a 45° angle while gently pulling upward. Clean both sides with warm soapy water on a damp cloth.

Do not soak or submerge the door in water or wash in the dishwasher.

4. Clean the inside of the appliance with hot water, a mild detergent and a nonabrasive sponge.
5. If necessary, remove unwanted food residue from the upper screen with a cleaning brush.

## Storage

1. Unplug the appliance and let it cool down thoroughly.
2. Make sure all components are clean and dry.
3. Place the appliance in the clean, dry place.

# Troubleshooting

Problem	Possible Cause	Solution
The <b>Power AirFryer Oven</b> does not work	The appliance is not plugged in. You have not turned the Unit on, by setting the preparation time & temperature	Plug power cord into wall socket. With basket in place, set the Temperature and Time. Check that door is closed.
Food not cooked	The Rotating Mesh Basket is overloaded. The temperature is set too low.	Use smaller batches for more even frying. Raise Temperature and continue cooking
Food is not fried evenly	Some foods need to be "turned" during the cooking process.	See General Operations in this manual.
White smoke coming from Unit	Oil is being used. Accessories have excess grease residue from previous cooking.	Wipe down to remove excess oil. Clean the Rotating Mesh Basket after each use.
French fries are not fried evenly	Wrong type of potato being used. Potatoes not rinsed properly during preparation.	Use fresh, firm potatoes. Use cut sticks and pat dry to remove excess starch.
Fries are not crispy	Raw fries have too much water.	Dry potato sticks properly before misting oil. Cut sticks smaller. Add a bit more oil.
Door came off	Door came off the hinge	As the door is slightly open (about 1 inch/2.5cm from the closed position), align the hinge so the joints fall into the slots. Then close the door.



# Frequently Asked Questions

---

**1. Can I prepare foods other than fried dishes with my Power AirFryer Oven?**

You can prepare a variety of dishes including steaks, chops, burgers, and baked goods.

See the **Power AirFryer Oven** Recipe Guide.

**2. Is the Power AirFryer Oven good for making or reheating soups and sauces?**

Never cook or reheat liquids in the **Power AirFryer Oven**.

**4. What do I do if the Unit shuts down while cooking?**

As a safety feature, the **Power AirFryer Oven** has an Auto Shut-Off device that prevents damage from overheating. Unplug and allow the Unit to cool down. Plug back in and restart with the Power Button.

**5. Does the Unit need time to heat up?**

Pre-heating is needed when you are cooking from a “cold start,” add 3 minutes to the cook time to compensate.

**6. Is it possible to shut off the Unit at any time?**

Press the Power Button once or open the door.

**7. Can I check the food during the cooking process?**

You can remove the Rotating Mesh Basket at any time while cooking is in progress. During this time, you can “flip” the contents on the Air Flow Racks if needed to ensure even cooking. Time and temperature will resume where you left off.

**8. Is the Power AirFryer Oven dishwasher safe?**

Only the accessories are dishwasher safe.

The Unit itself containing the heating coil and electronics should never be submersed in liquid of any kind or cleaned with anything more than a hot, moist cloth or nonabrasive sponge with a small amount of mild detergent.

**9. What happens if the Unit still does not work after I have tried all the troubleshooting suggestions?**

Never attempt a home repair. Contact the manufacturer and follow the procedures set forth by the warranty. Failure to do so could render your warranty null and void.

**10. Can the door come off?**

Yes it can. Open the door slightly (about 1 inch/2.5cm from the closed position), and gently lift up on the door hinge. The joints will slide out. You may clean the unit and windows more easily. To put the door back on, have the door slightly open as before, then align the hinge so the joints fall into the slots. Then close the door.

# **PowerAirFryer Oven™**

## **Manufacturer's Sixty Day Limited Warranty**

The manufacturer warrants that all parts and components are free of defects in materials and workmanship for 60 days. This warranty is valid only in accordance with the conditions set forth below:

1. The warranty extends only to the original consumer purchaser and is not transferable. In addition, proof of purchase must be demonstrated.
2. This limited warranty is the only written or express warranty given by the manufacturer. Any implied warranty of merchantability or fitness for a particular purpose on this product is limited in duration to the duration of this warranty. Some states do not allow limitations on how long an implied warranty lasts, so the above limitation may not apply to you.
3. This warranty gives you specific legal rights, and you may also have other rights which vary from state to state.

### **Procedure for Replacement or Return within the 60 days :**

To return the product for replacement or refund within the 60 days, the original purchaser must pack the product securely and send it postage paid with a description of the reason for replacement or refund, proof of purchase, and include your order number on the package, to the following address:

Tristar Products, Inc.,  
500 Returns Road,  
Wallingford, CT 06495.

***PowerAirFryer***  
***Oven***<sup>TM</sup>





# ***PowerAirFryer Oven™***

We are very proud of the design and quality of our  
***Power AirFryer Oven™***.

---

This product has been manufactured to the highest standards.  
Should you have any problem, our friendly customer service  
staff is here to help you.  
**973-287-5197**



Distributed by:  
Tristar Products, Inc.  
Fairfield, NJ 07004  
© 2017 Tristar Products, Inc.  
Made in China  
PAFO\_UL\_IB\_TP\_ENG\_V2\_171010

