

OPTIONAL TOP UNIT INSTALLATION INSTRUCTION

THESE INSTRUCTIONS WERE PREPARED TO PROVIDE YOU INFORMATION ON HOW TO INSTALL CHEESE MELTER ARCM OR SALAMANDER ARSM. BEFORE PROCEEDING CHECK ALL PARTS INCLUDED IN PACKAGE ACCORDING TO PART LIST INCLUDED WITH KIT.

REQUIRED TOOLS:

PHILLIPS SCREWDRIVER, WRENCH - 3/8" STANDARD SIZE.

PARTS LIST:

CHANNEL ITEM #5.....	1
CHANNEL ITEM #7.....	1
BOLTS 1/4-20 1" LONG.....	6
NUTS 1/4-20.....	6
WASHER #6.....	6

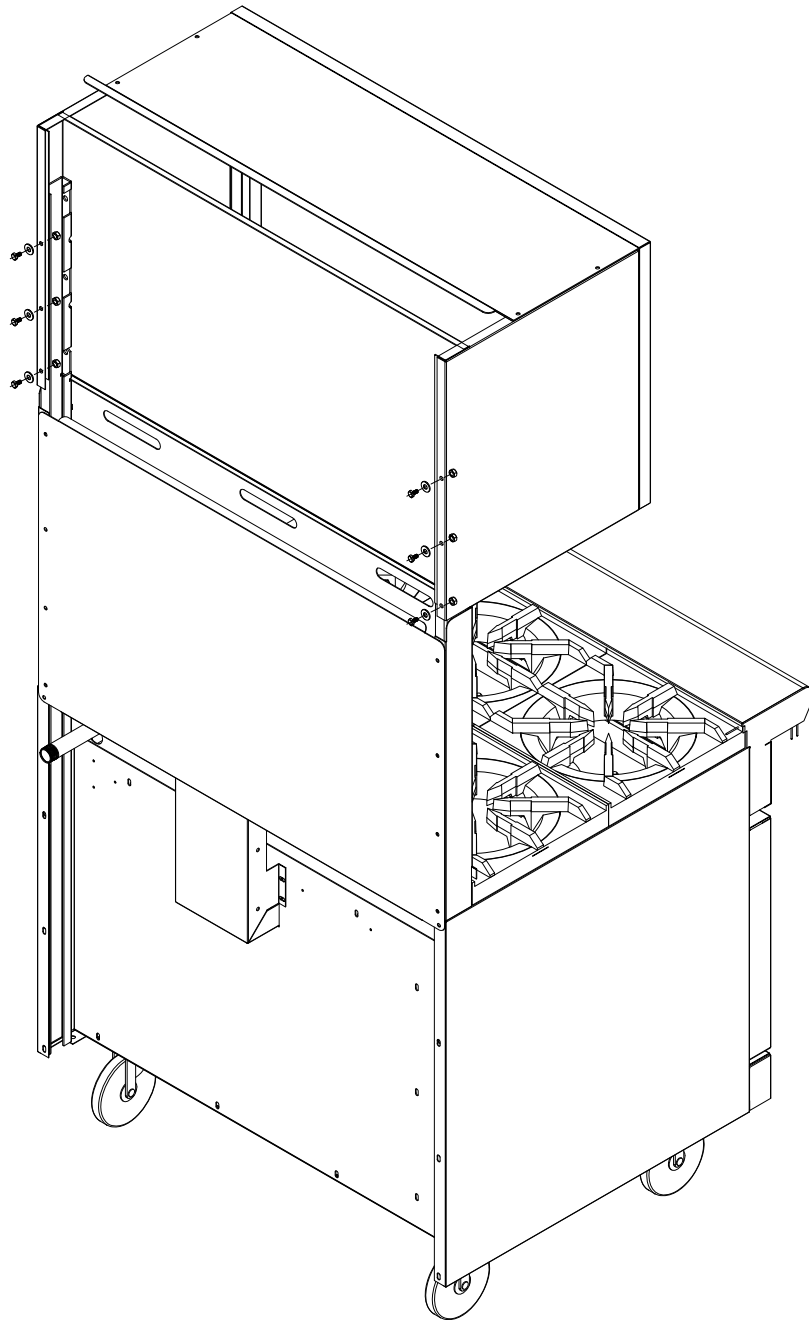

STEP 10.

SECURE CHEES MELTER (SALAMANDER)
TO CHANNELS WITH COMBINATION OF
3 BOLT, 3 NUT AND 3 WASHER ON EACH CHANNEL.

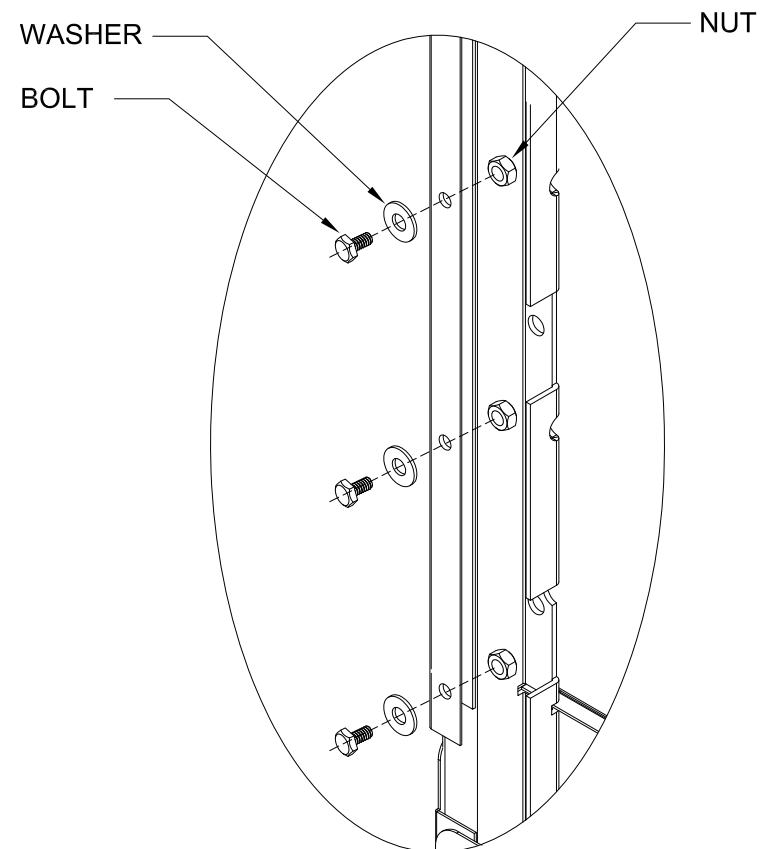

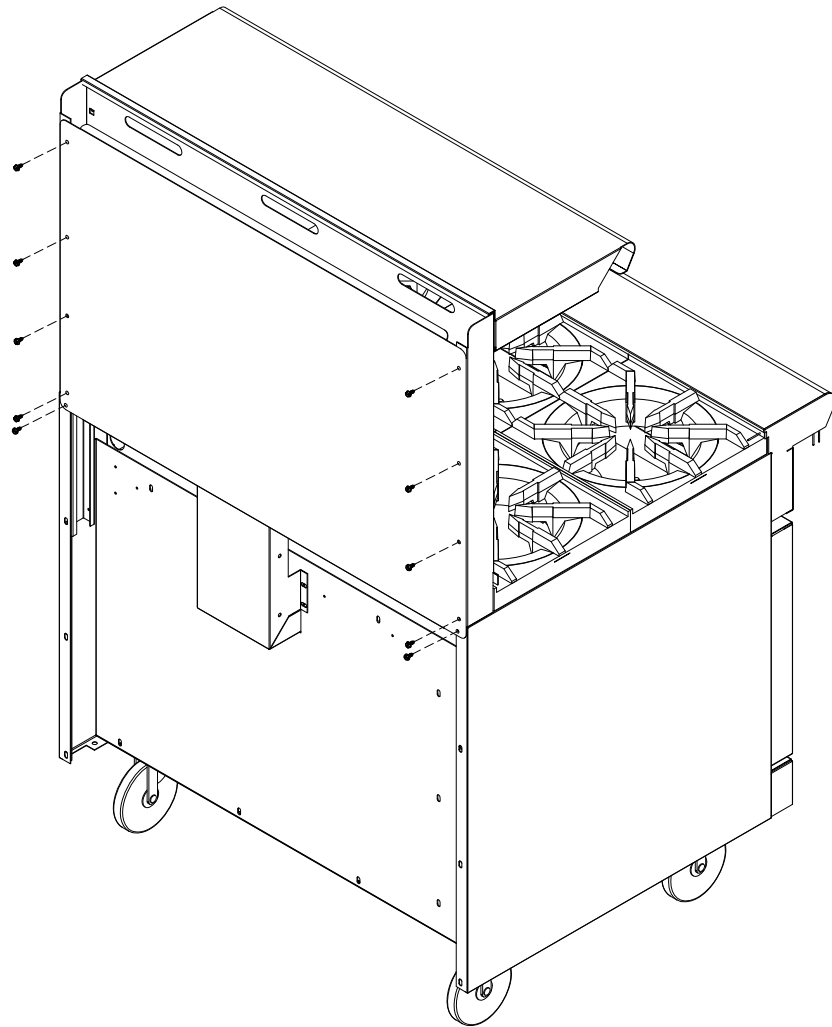

STEP 2.

REMOVE 10 SCREWS FROM THE REAR HRISER.
REMOVE REAR HRISER.

REMOVE ALL 10 SCREWS
FROM REAR HRISER

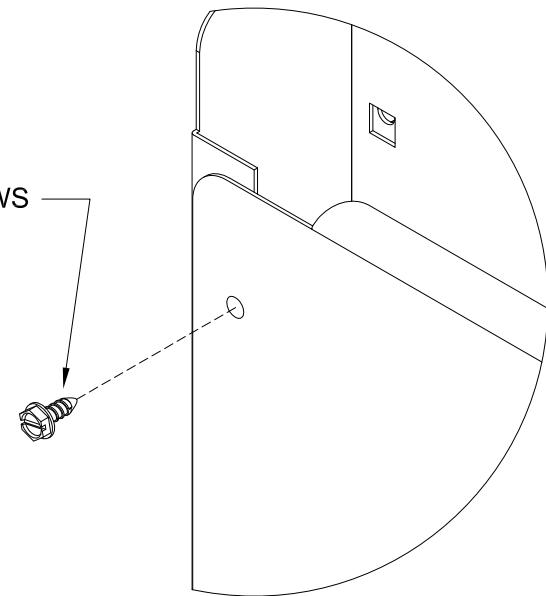

STEP 3.

SLIDE UP TOP SHELF AND FRONT HIRISER.

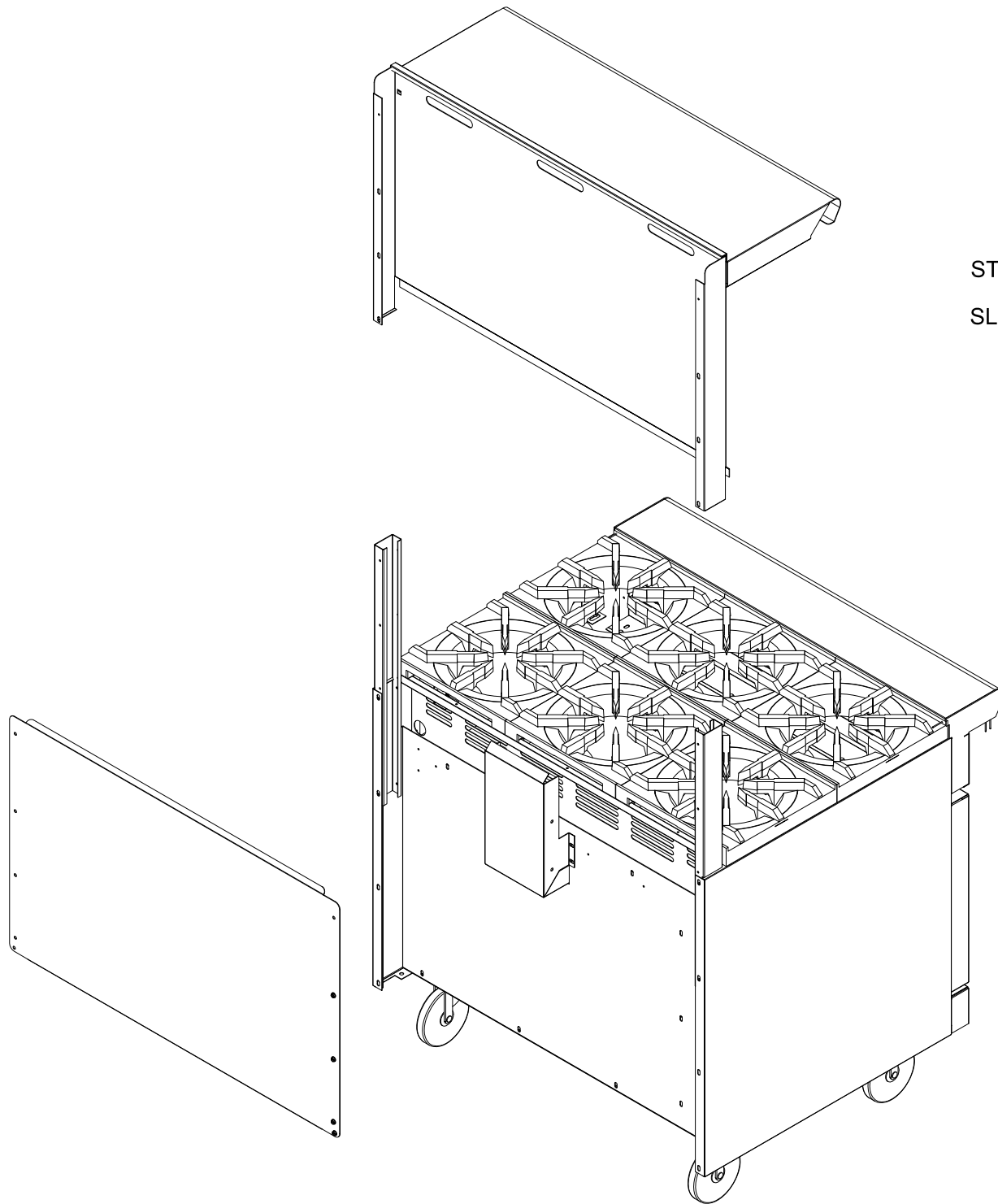

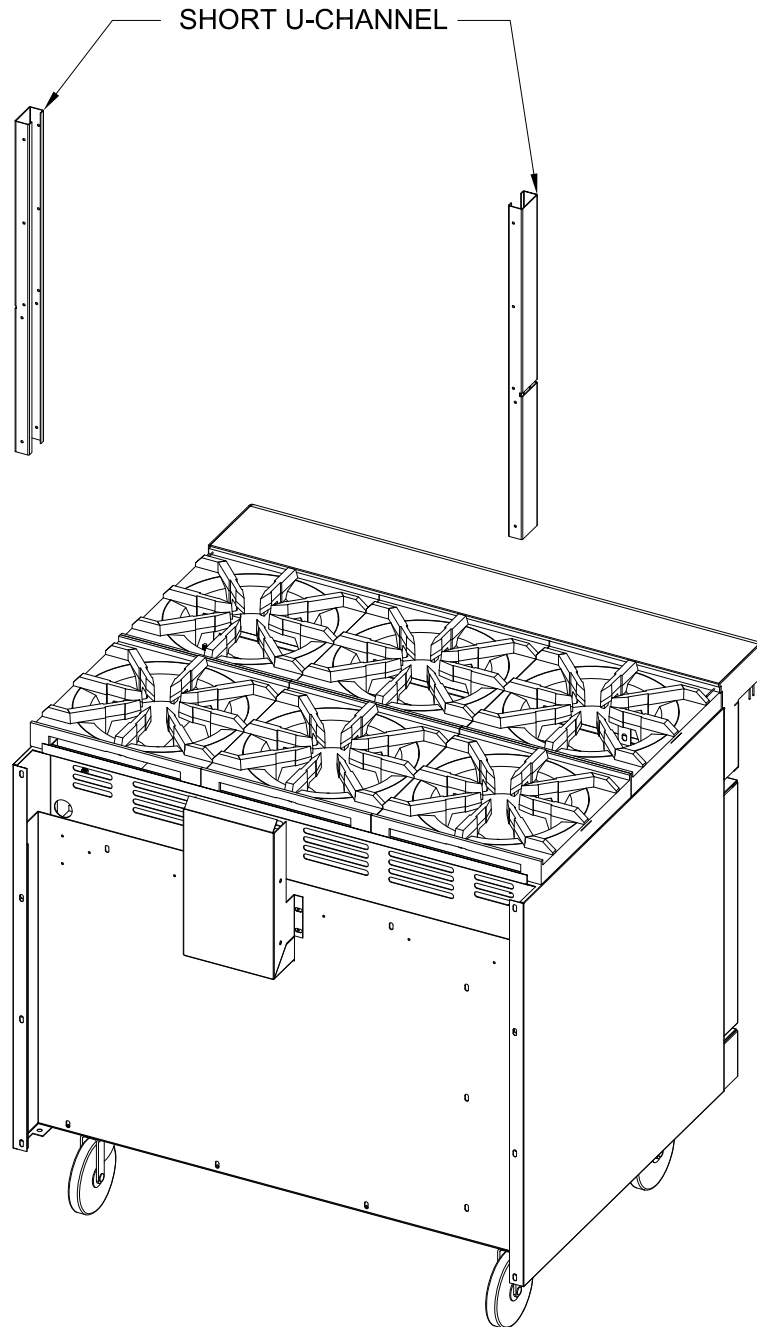

STEP 4.

SLIDE UP TWO SHORT U-CHANNELS
AND STORE FOR FUTURE USE.

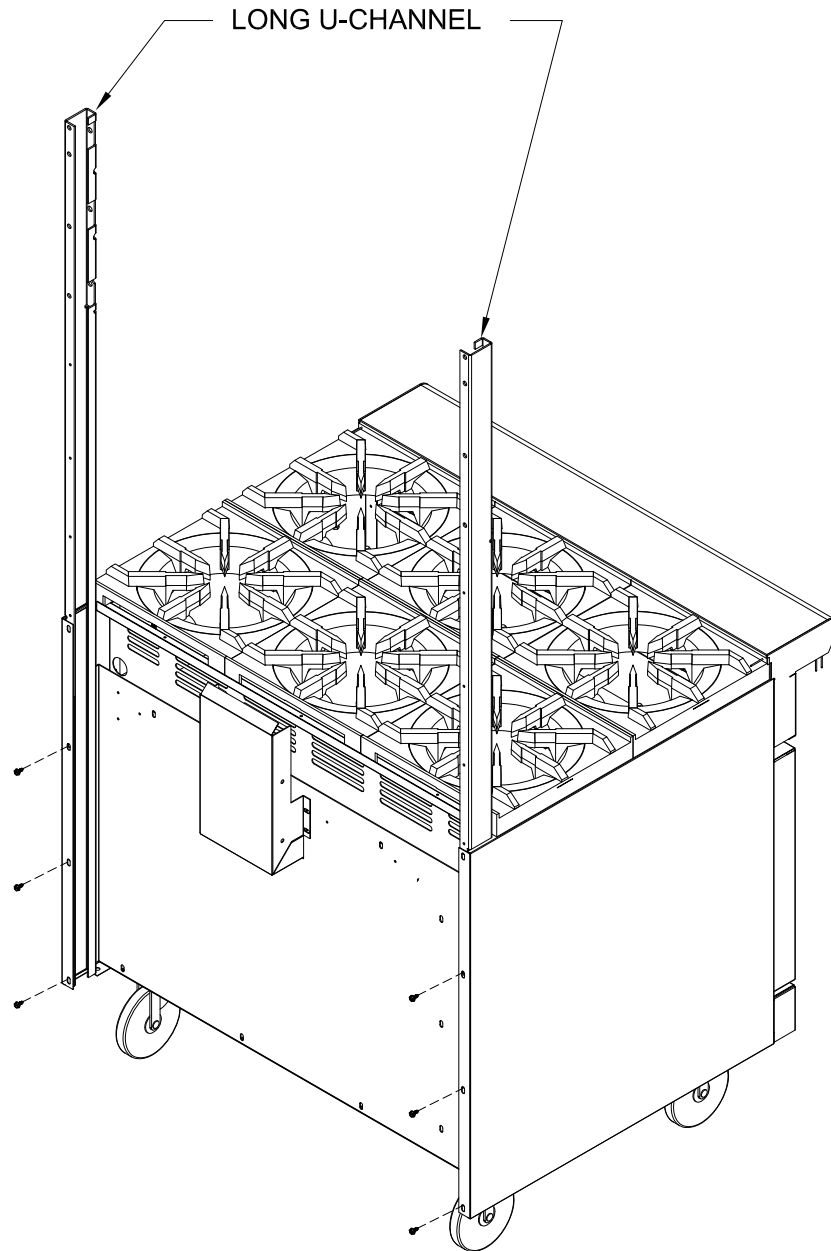

STEP 5.

SLIDE IN TWO LONG U-CHANNELS PROVIDED WITH KIT AND SECURE EACH CHANNEL WITH 3 SCREWS.

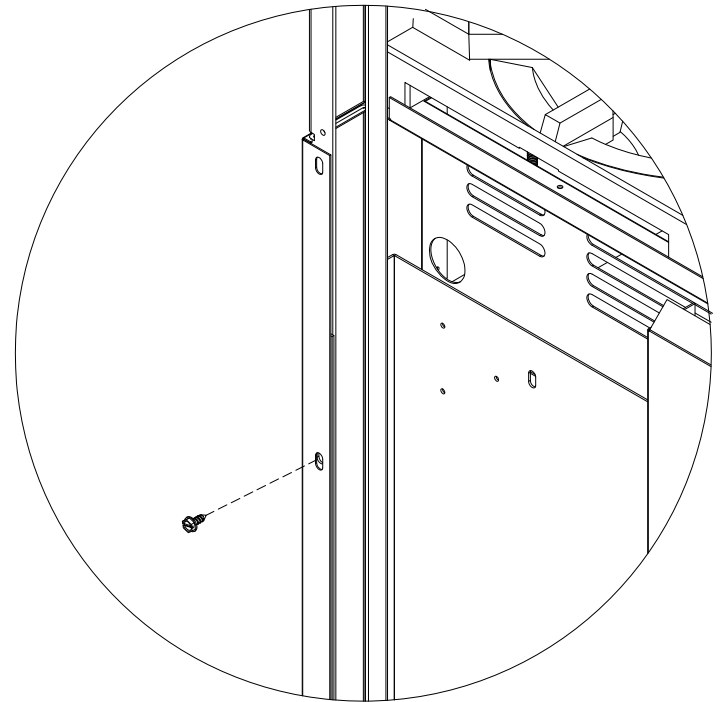

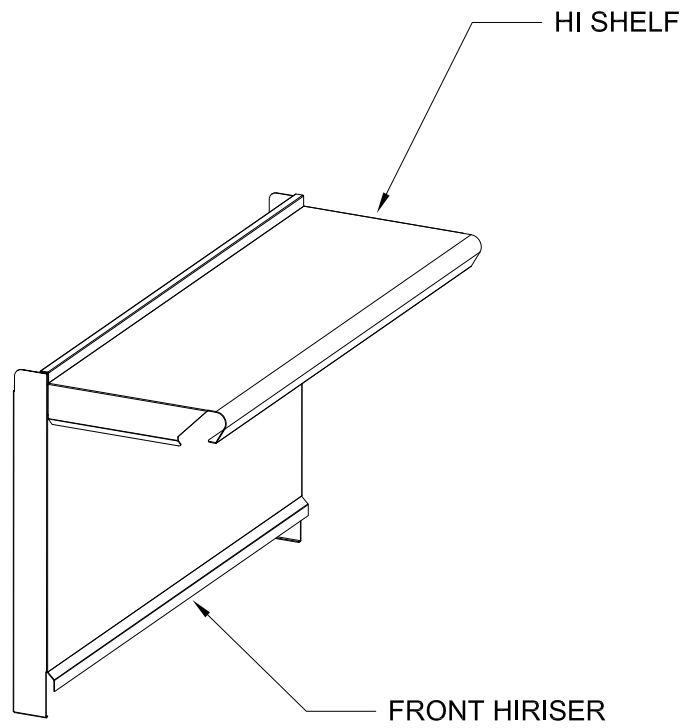

STEP 6.

DISCONNECT HI SHELF
FROM FRONT HIRISER BY REMOVING BOLTS.
STORE TOP SHELF FOR FUTURE USE.

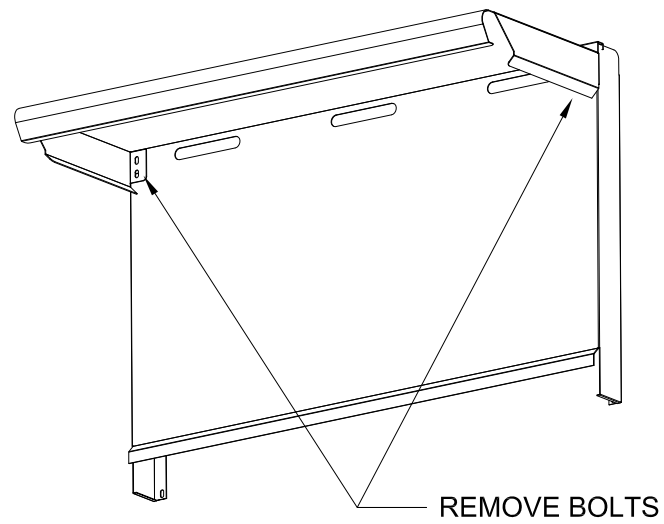

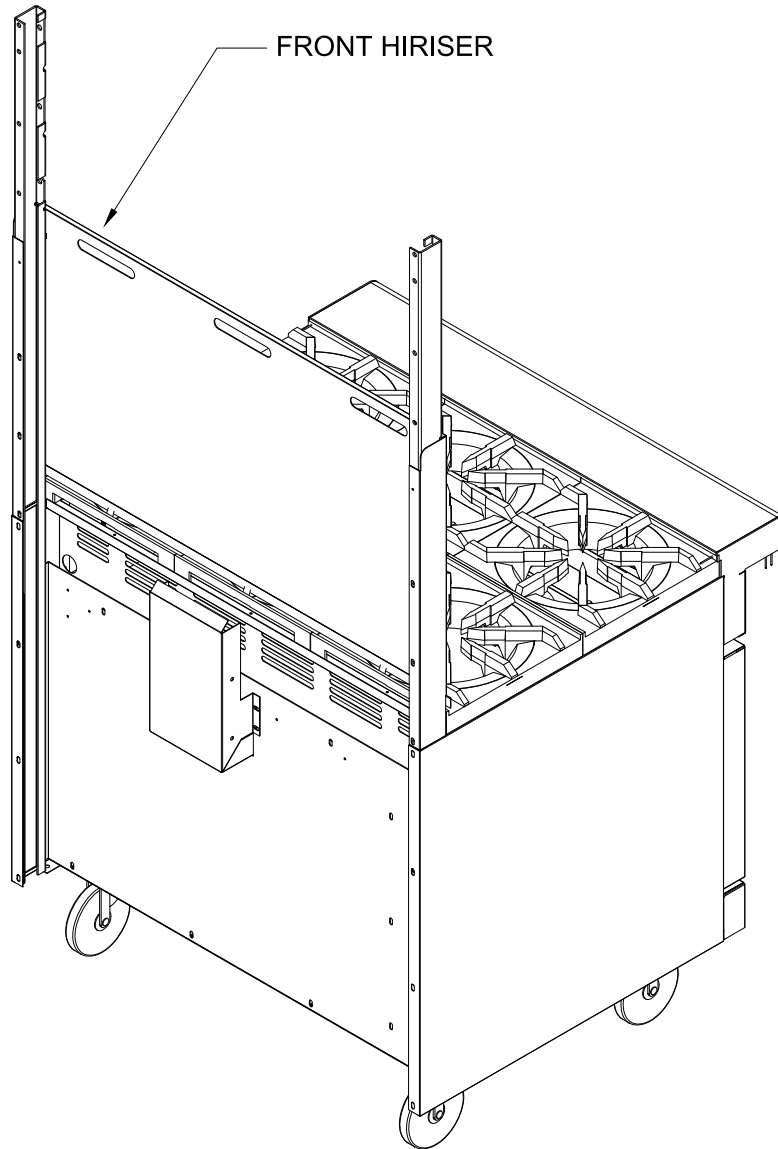

STEP 7.

SLIDE IN FRONT HIRISER AND ALIGN WITH CHANNEL HOLES.

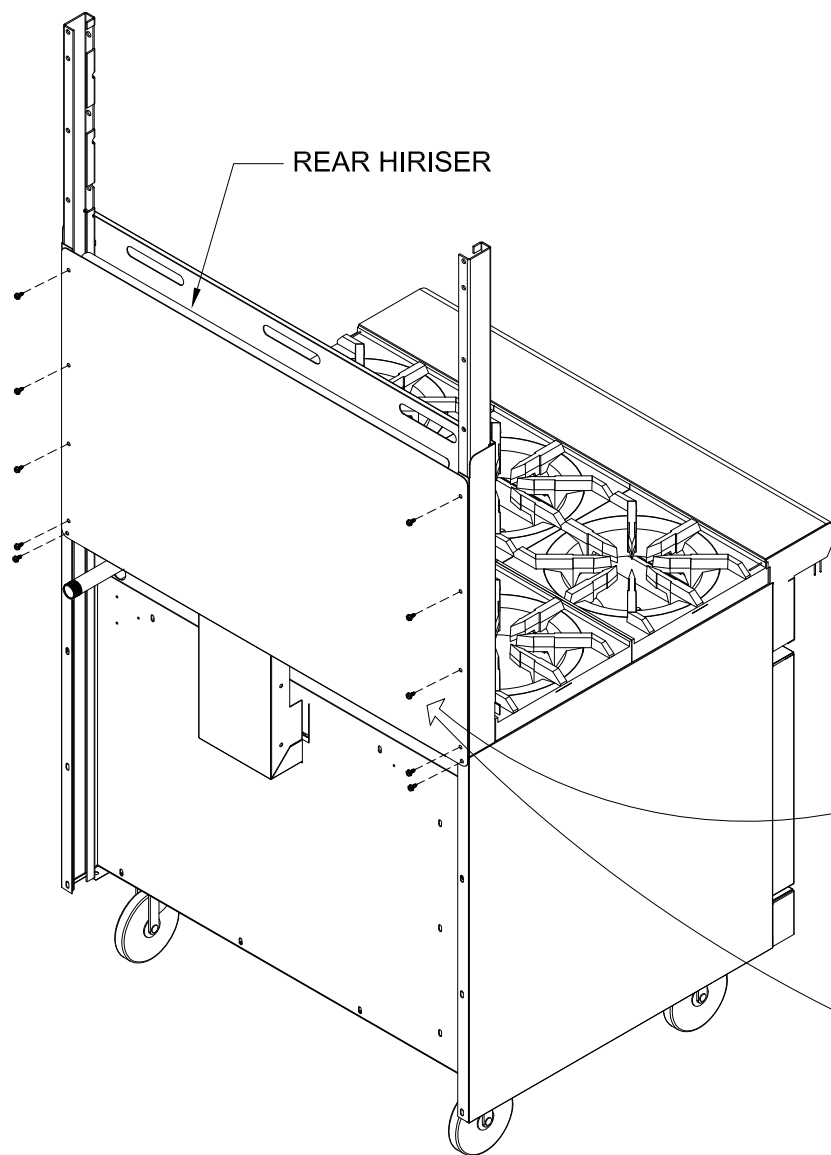

STEP 8.

PLACE REAR HIRISER FACING THE CHANNEL. THE TOP BEND SHOULD BE TOWARD FRONT OF THE OVEN. SECURE WITH 10 SCREWS AND TIGHTEN.

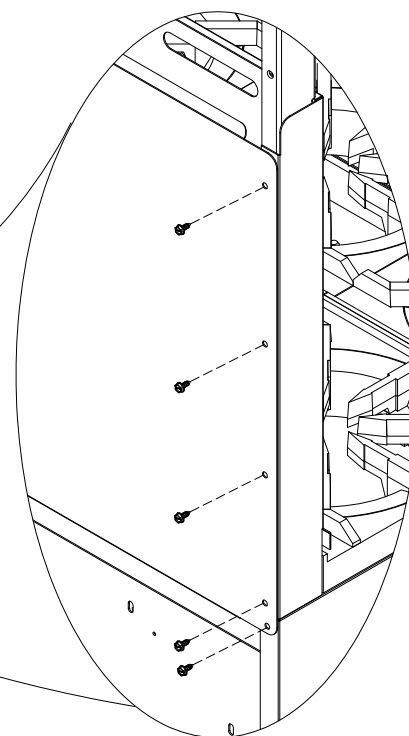

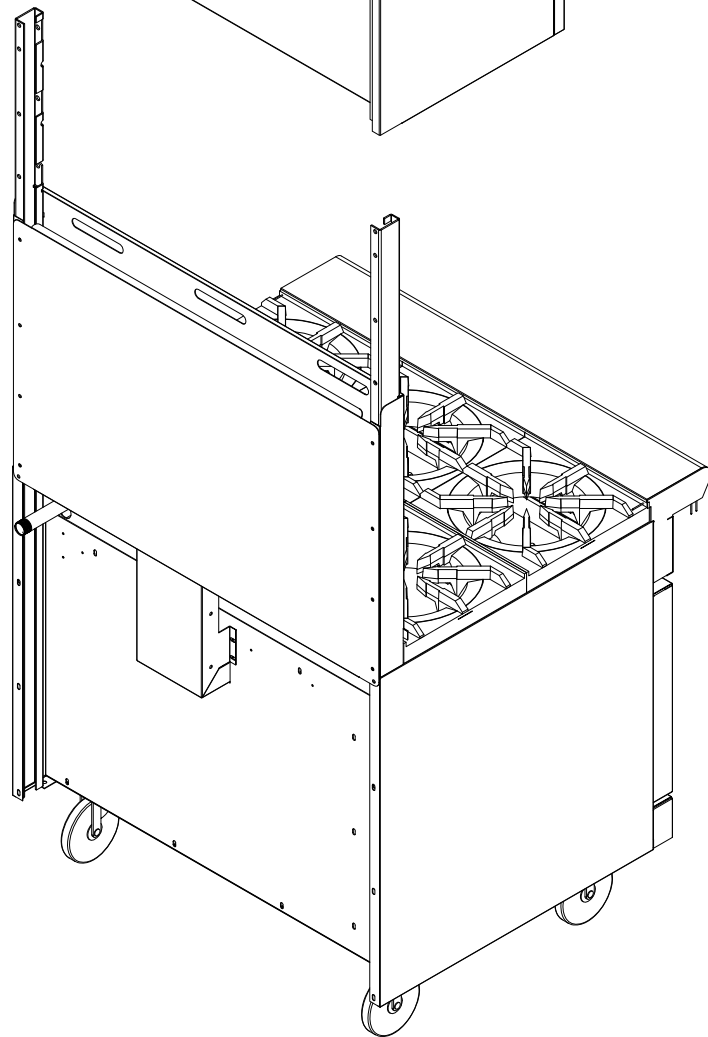
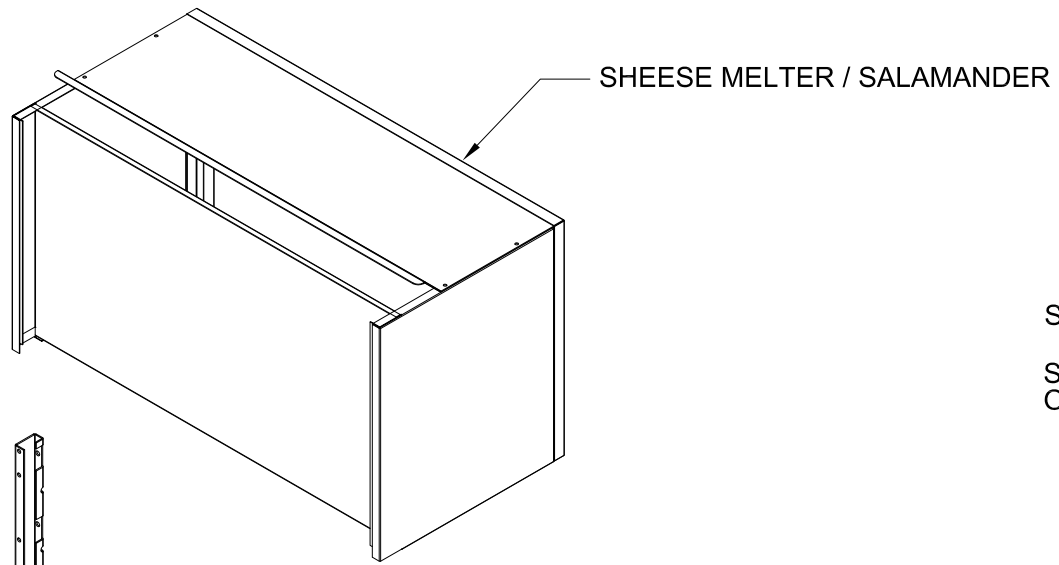

STEP 9.

SLIDE CHEESE MELTER OF SALAMANDER
ONTO BRACKETS AND ALIGN HOLES.