

Before you enjoy your ride, please read this user manual carefully.

## IMPORTANT SAFETY INSTRUCTIONS

### WARNING

When using this product, basic safety precautions should always be followed:

1. Please read and follow all safety instructions in this manual. When riding in public areas, obey all national and local traffic laws, stay alert, and maintain a safe distance from pedestrians and vehicles.
2. Read all the instructions before using the product. Do not modify or unlock the speed limit without authorization. Any damage caused by improper or unauthorized operation is the user's responsibility.
3. To reduce the risk of injury, close supervision is necessary when the product is used near children.
4. Do not put fingers or hands into the product.
5. Do not use this product if the flexible power cord or output cable is frayed, has broken insulation, or any other signs of damage.
6. This product is not designed for professional off-road or stunt riding. Do not ride up or down stairs, jump, perform wheelies, or attempt similar actions.
7. For your first ride, practice in a safe, traffic-free area. Only ride on public roads after becoming fully familiar with the product.
8. Before each ride, check for loose fasteners or damaged parts. If you hear abnormal sounds or notice damaged cables or insulation, stop riding immediately and contact our service team.
9. Do not ride at excessive speed. When riding on public roads, always obey local traffic regulations and keep a safe distance from motor vehicles.
10. For safety reasons, this product must not be used by persons under 14 years old. Do not ride if you are under the influence of alcohol or drugs, have medical conditions that limit physical activity, cannot maintain balance, exceed the maximum load limit, or are pregnant.
11. Use extra caution when riding in rain, snow, on wet, icy, or slippery surfaces, or in any other adverse conditions.
12. Do not charge the product if the charger or power outlet is wet. When charging in public places, comply with local safety regulations.
13. Only use manufacturer-approved parts and accessories to ensure proper performance and safety.
14. Do not modify the product without consulting our service team and ensuring compliance with local laws. The manufacturer is not responsible for any injury or damage caused by unauthorized modifications.
15. Follow all "Caution," "Danger," and "Warning" notices in this manual to reduce the risk of injury.
16. The battery is intended to be charged when the ambient temperature is between 0°C (32°F) and 40°C (104°F) Never charge the battery when ambient temperatures are outside this range.
17. This equipment is not intended to be used at ambient temperatures less than 0°C (32°F) or above ambient temperatures of 40°C (104°F)

### SAVE THESE INSTRUCTIONS

- **Danger:** Ignoring This Notice May Result In Serious Injury Or Death. Follow All Required Instructions.
- **Warning:** Ignoring This Warning May Cause Damage To The Vehicle Or Its Components. Follow All Required Instructions.
- **Caution:** Ignoring This Caution May Result In Minor Damage Or Reduced Performance. Follow The Recommended Instructions.

## 1. Product Introduction

- 1.1 Packing list
- 1.2 Components
- 1.3 Functions
- 1.4 Display functions

## 2. Quick Guide

- 2.1 Installation guide
- 2.2 How to fold
- 2.3 How to remove the battery
- 2.4 How to charge
- 2.5 Battery activation
- 2.6 Quick operation instructions
- 2.6 Instrument setting

## 3. User Maintenance Instructions

- 3.1 Notes for operation
- 3.2 Maintenance and self-inspection
- 3.3 Troubleshooting
- 3.4 Rear derailleur cage precautions

## 4. Service Guide

- 4.1 After-sales service and warranty coverage
- 4.2 Warranty card and repair record
- 4.3 Product parameters



APP Download



Assembly video

## 1.PRODUCT INTRODUCTION

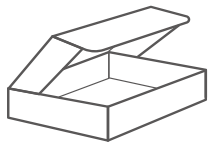

Manual



8-10 13-15 14-15

Wrench



Charger



M4 M5 M6

Screwdrivers



Screwdriver



Air Pump



Spare parts kit



Saddle



Handlebar  
Foldable riser / Stem



Front Mudguard



Kickstand

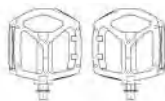

Pedal x 2

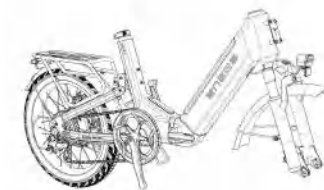

Frame body



Front tire

### 1.1 PACKING LIST

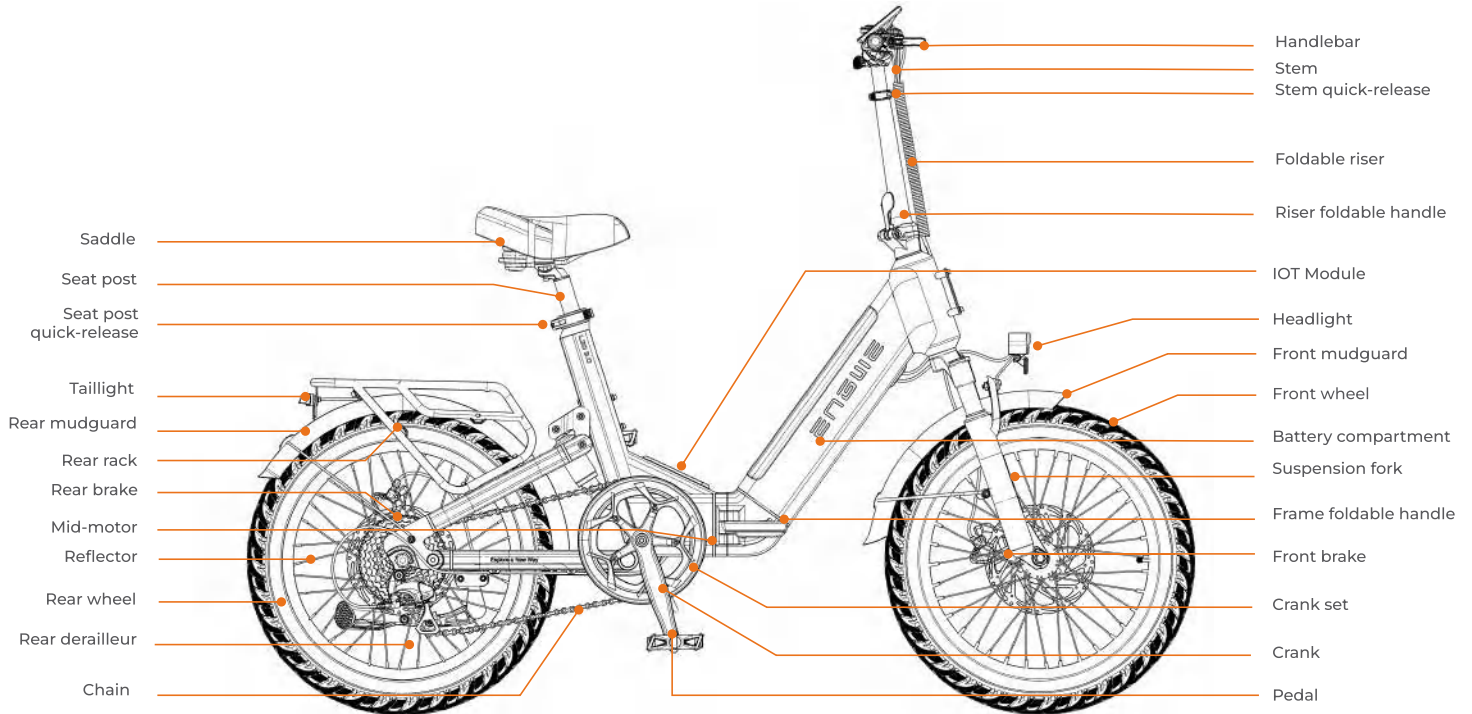

All images are for reference only. The actual product may vary.



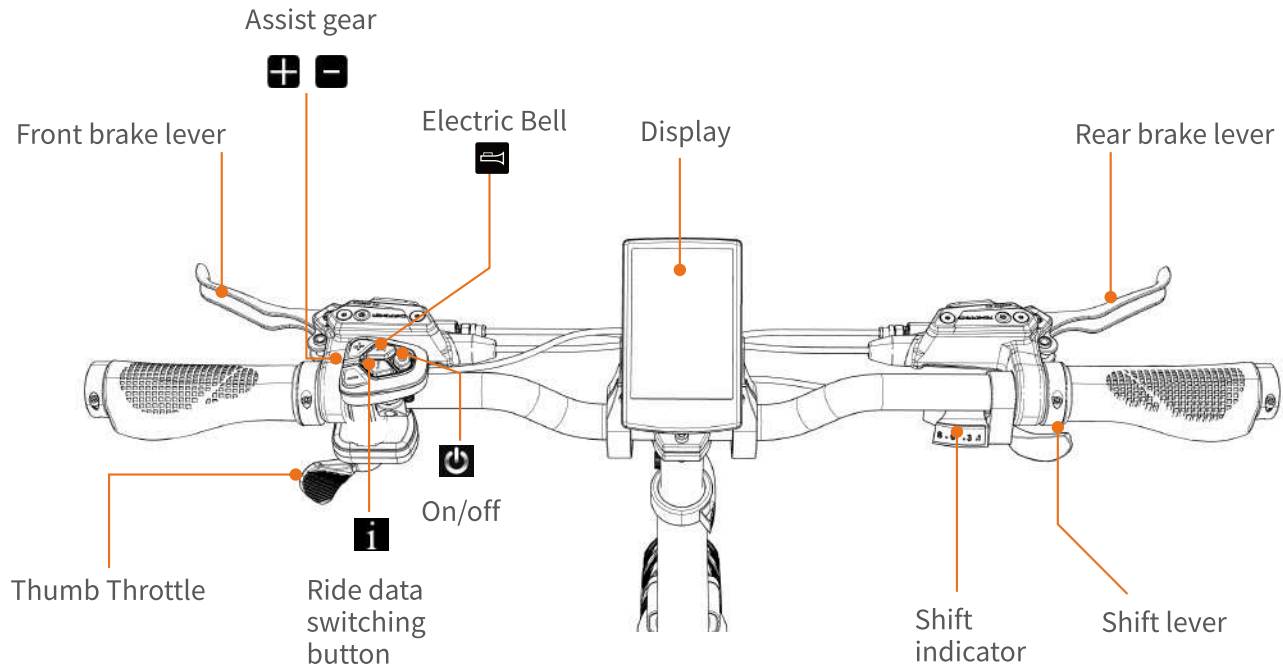



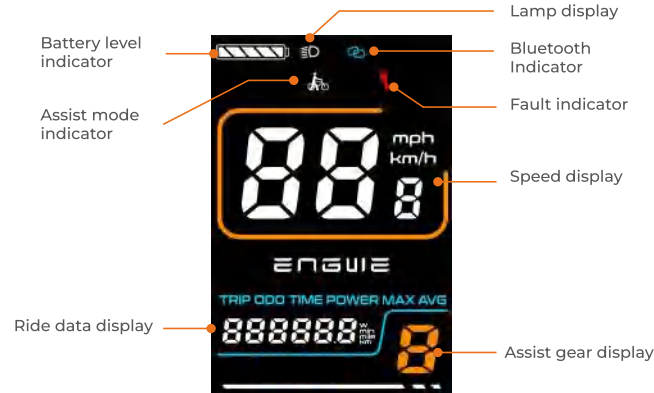





## 1.PRODUCT INTRODUCTION



### 1.3 FUNCTIONS



### Common functions

1. Power-on/off: press  for 2s to power on, and hold  for 2 s to power off.
2. Assist gear adjustment: press  /  to adjust the gear.
3. Assist: press and hold the  button to enter the assist mode. The speed is 3MPH, and the screen display the assist mode icon . Release the button , then the assist mode stops immediately, and the assist mode icon  disappears.
4. Electric horn: press  to alert.
5. Headlight switch: press  button about 2 s, the lights turn on, and instrument brightness will dim; Press the  button again, then the lights are turned off and instrument brightness is restored.
6. Riding data switching: after the instrument screen is turned on, the instrument screen will display the real-time speed and trip meter by default. Press the  button to switch the display information between the trip meter, odometer, maximum speed and average speed.
7. Fault code indication: when the electronic control system of the electric bike fails, the instrument will automatically display the fault code. For the definitions of fault codes, see 3.3 Fault codes.

## 2. QUICK GUIDE

- Warning: The bike shall be disassembled and assembled by two individuals. Before assembling, make sure that the power system is turned off and will not be turned on accidentally.



 Maximum load 150KG

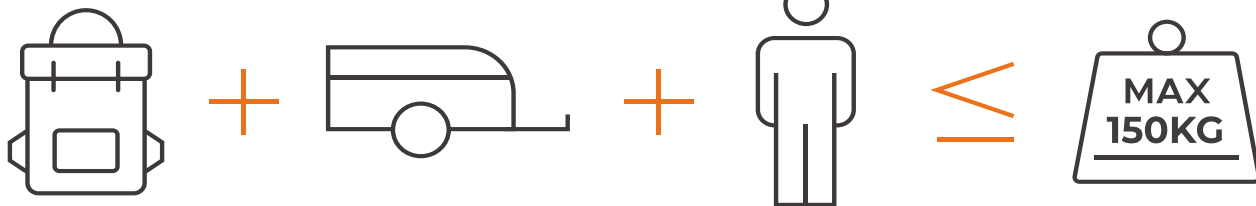



1



2

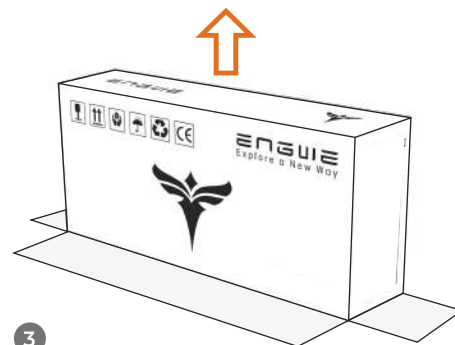

3



Hold it  
Prevent falling

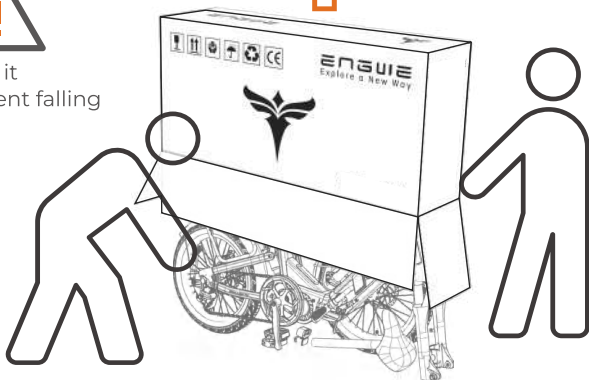

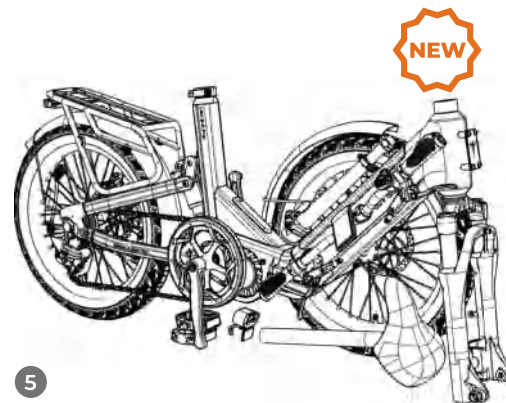

4



5

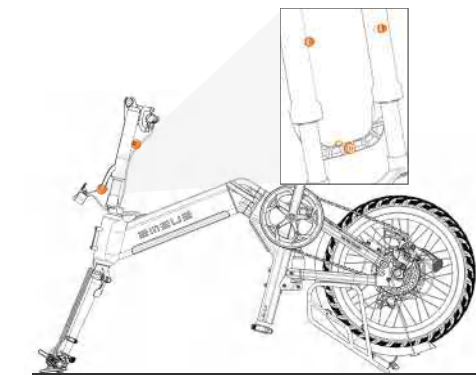



- 1  Protect the instrument screen. Do not press it

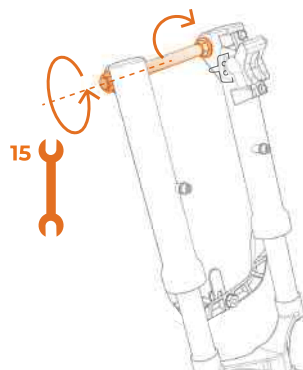

2

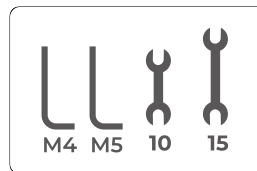

Warning: Clockwise direction is to tighten, counterclockwise direction is to loosen.

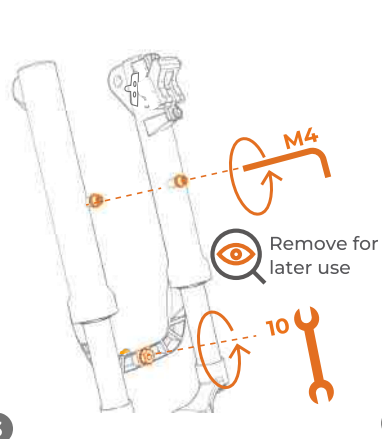

3

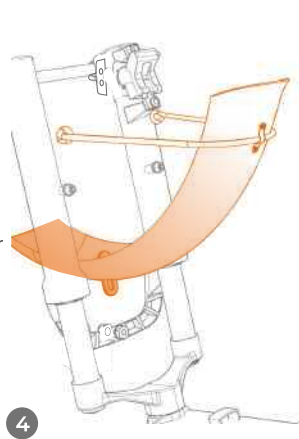

4

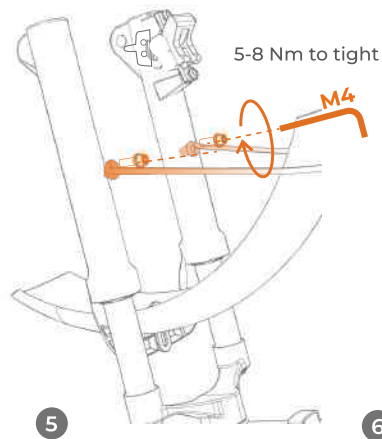

5

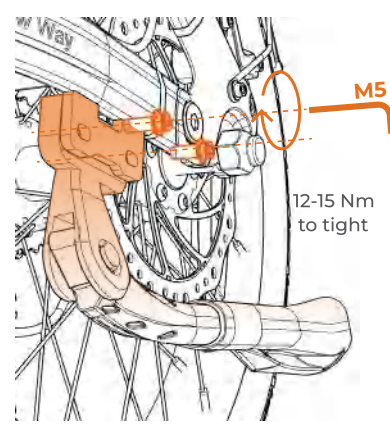

6

## 2. QUICK GUIDE

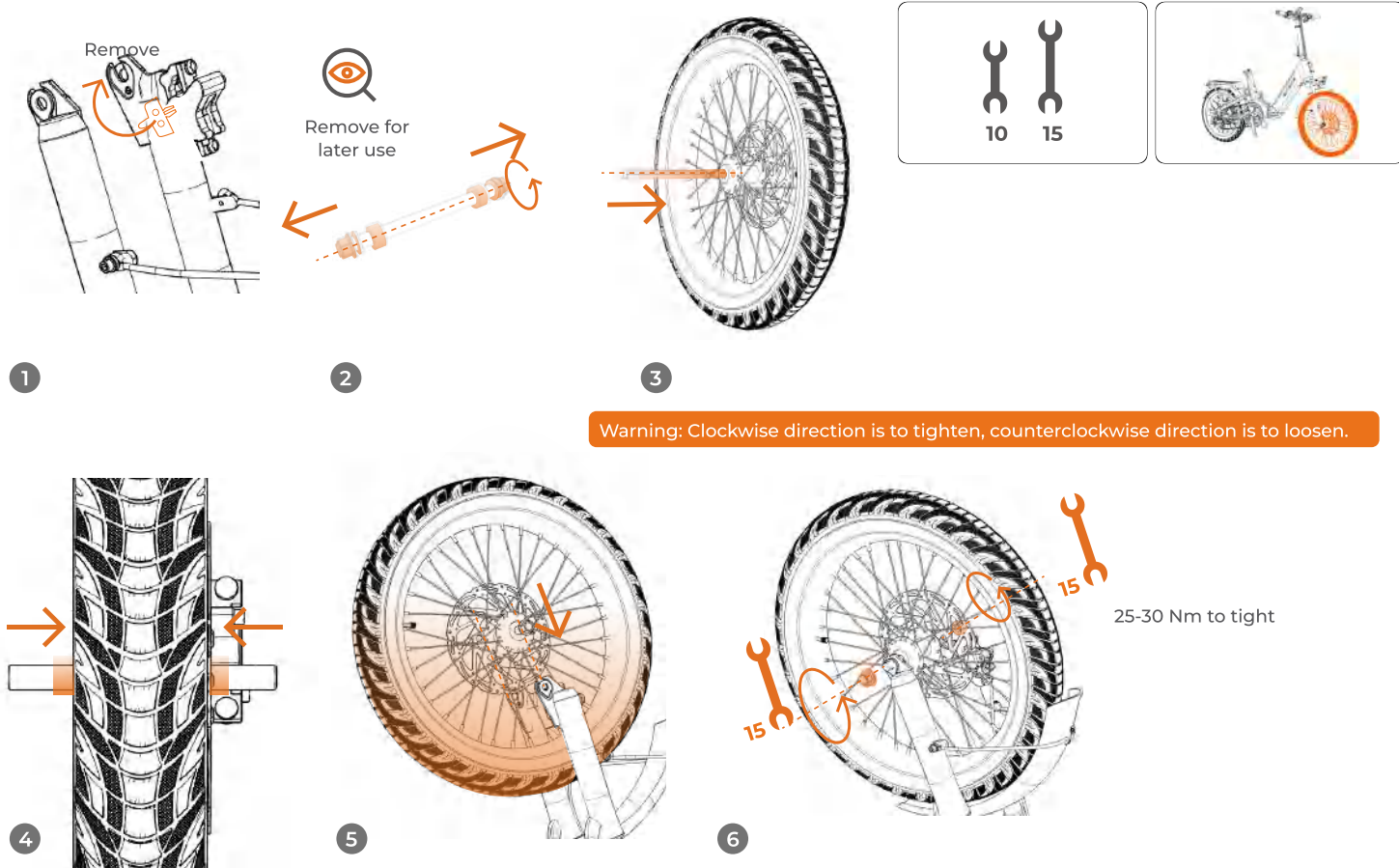

### 2.1.5 INSTALLATION GUIDE - WHEEL



The white safety line must remain covered

The highest seat height is the 0 scale line, and the lowest seat height is 10 scale line.

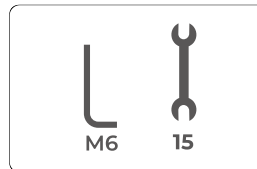

1. Sit On The Saddle, Keep Your Hips Level,
2. Turn The Pedals To Be Perpendicular To The Ground, And Step Your Heels On The Pedals.
3. If Your Knees Are Straight At This Time, You Have Obtained Your Saddle Height.

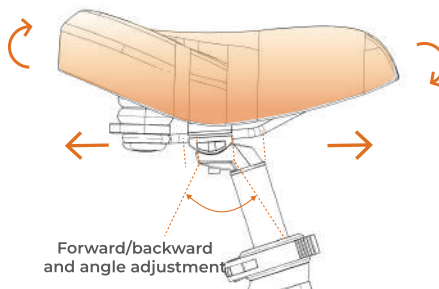
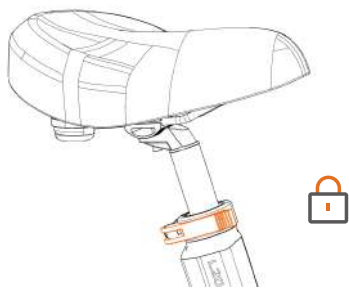

Forward/backward and angle adjustment

3

4

## 2. QUICK GUIDE

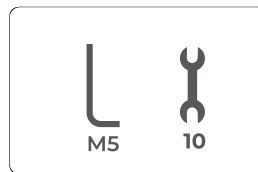
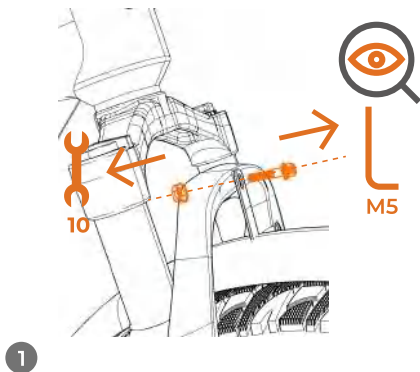

Warning: Clockwise direction is to tighten, counterclockwise direction is to loosen.

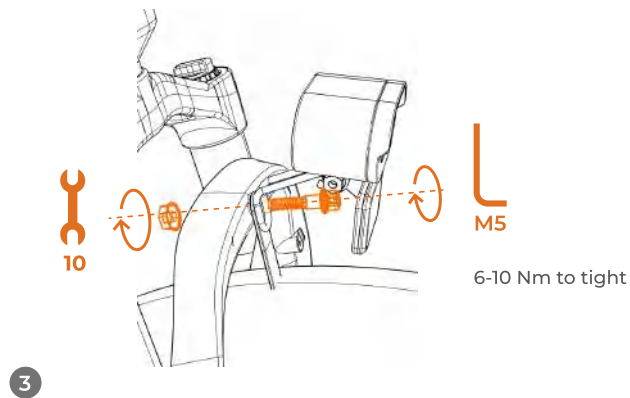
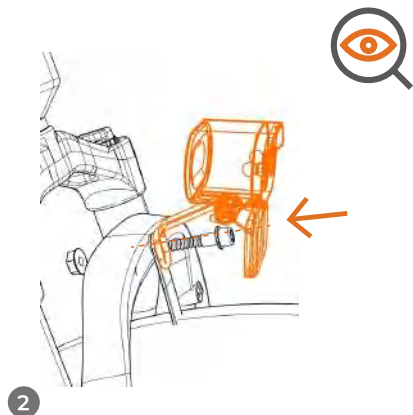

### 2.1.7 INSTALLATION GUIDE - HEADLIGHT



Distinguishing between left and right

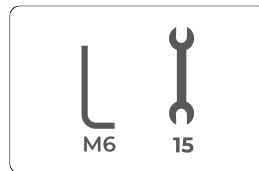
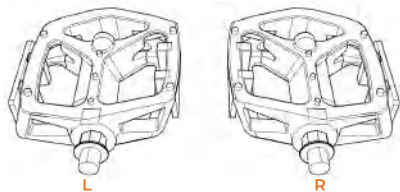

1

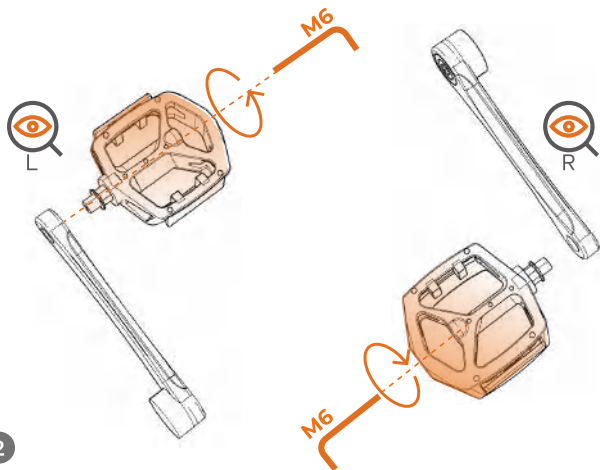

2

35-40 Nm to tight

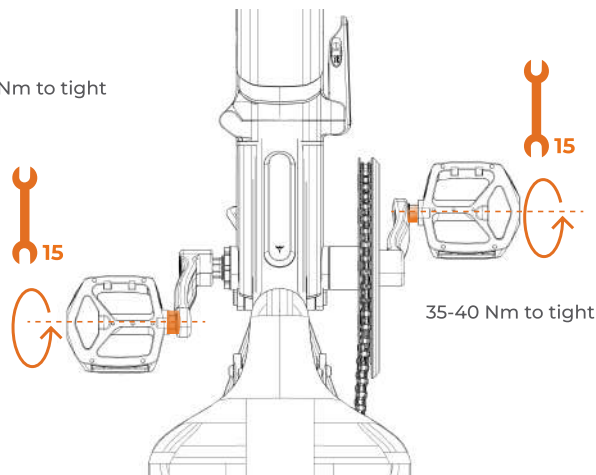

3

## 2. QUICK GUIDE

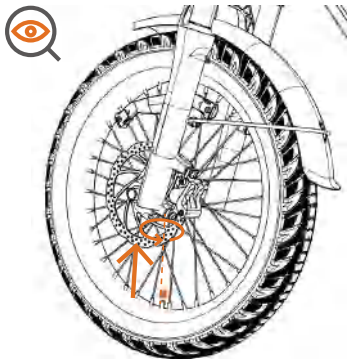

1 Remove the plug

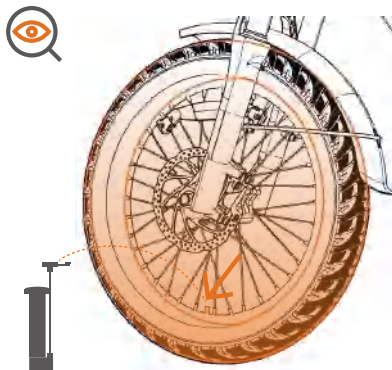

2

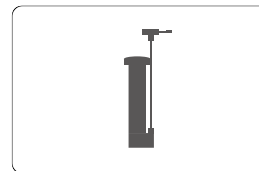

3 put it back



To protect the tires,  
we deflated the tires before transportation.  
Please fill the tires to the recommended  
pressure before riding.



3



Congratulations!  
Your bike has been assembled  
successfully!

## 2. QUICK GUIDE

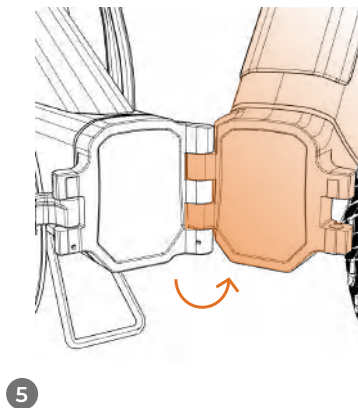
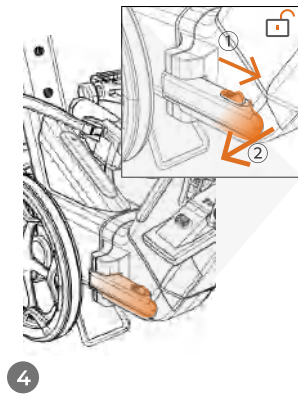
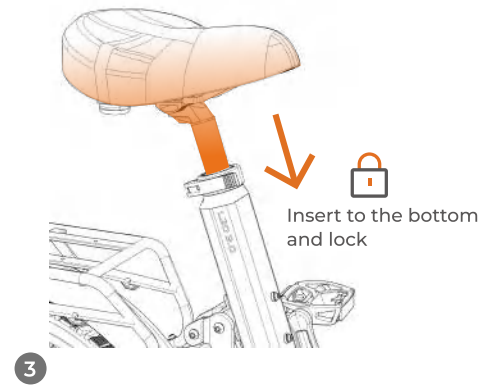
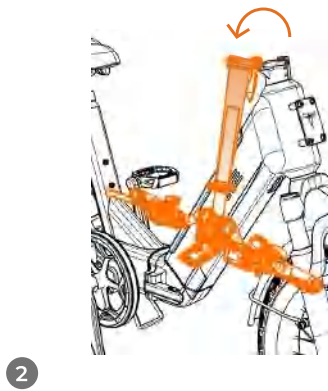
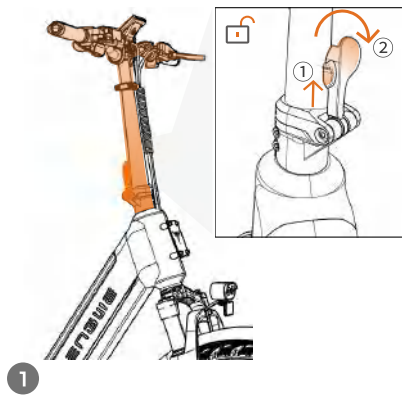

  
Pull out the  
dust plug

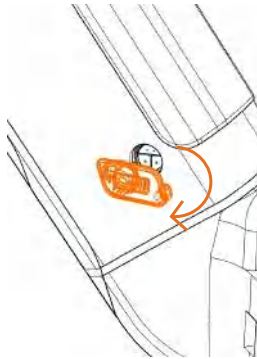

1



2

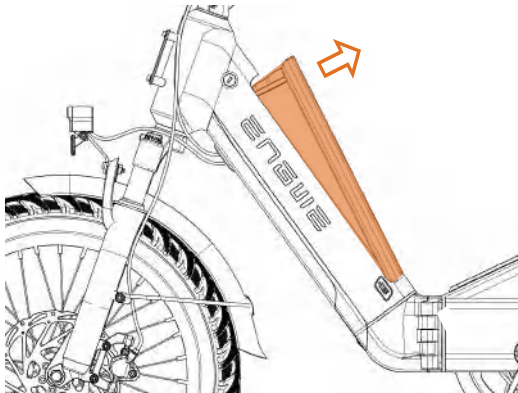
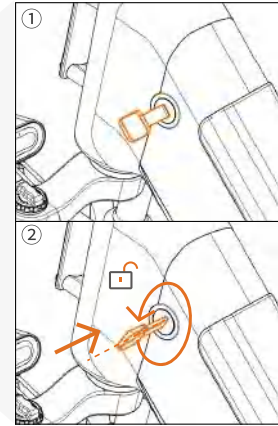

3



Please remove the key when riding,  
and make sure the battery is installed well.



When removing the battery, be careful not  
to let it fall to the ground and cause collision.



The battery contains composite materials  
other than metal. If you encounter severe  
impact during use, such as a car accident,  
please return it for inspection or destroy and  
replace it (not free of charge)

## 2. QUICK GUIDE

### Two Charging Methods

① Charge the battery on the frame directly

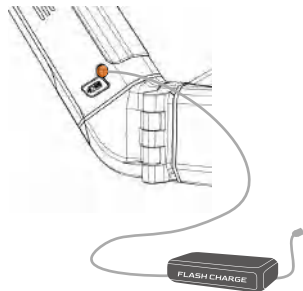

② Remove the battery for charging (see 2.3 for the removal method of the battery)

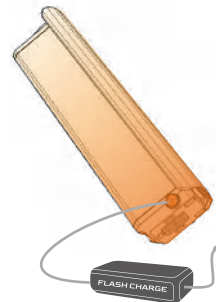

- Note: The battery remains a small amount of electricity when the product leaves the factory. Before the product is used for the first time, please charge it fully. Please make sure to use the manufacturer's original charger that comes with the bicycle to charge the bicycle battery. Non-original chargers may cause battery damage.

### Steps

- 1. Before charging:** Please ensure that the charging environment has normal air circulation and is dry; check that the charger plug and socket are dry and free of foreign objects; avoid charging in direct sunlight; avoid charging in an environment with a temperature below 5 degrees Celsius and above 30 degrees Celsius; ensure that there is no accumulation of flammable materials at the charging area
- 2. Start of charging:** Fully insert the charger connector into the battery's charging port, and then fully insert the charger's power plug into the power socket.
- 3. Status indication:** When the charging indicator lamp on the charger is red, it indicates that the charging is normal; When the indicator lamp is green, it indicates that the battery is fully charged. Flashing Green light means ready to charge and no output; Flashing Red light means fault.
- 4. Charging time:** about 2 hours
- 5. End of charging:** Unplug the power plug first, and then remove the charger connector from the battery. To charge by the method indicated in ①, just close the battery's dust plug. To charge by the method indicated in ②, you must insert the battery into the frame and secure it, and then close the battery's dust plug.

- Note: The charger contains a high-voltage device. Unauthorized repairs are strictly prohibited due to the risk of danger. The battery and the charger must be placed in a safe, well-ventilated, and dry area, beyond the reach of children, and away from any flammable, explosive, or hazardous items (such as saddles, sofas, etc.). Additionally, charging may not be conducted outdoors to prevent accidents like electrical short circuits and fires due to rain or similar elements.
- Warning: If you detect an unusual odor or if the battery or charger becomes excessively hot during charging, stop charging immediately and contact the after-sales team.

## 2.4 HOW TO CHARGE

### Before first use, please activate the battery:

1. Charge according to 2.4 how to charge.
2. After the green light flashes, the red light is always on. Please wait for about 10 seconds to complete the battery activation.

Since it is the first time to use, it is recommended that you charge for about 30 minutes to get a longer first ride.

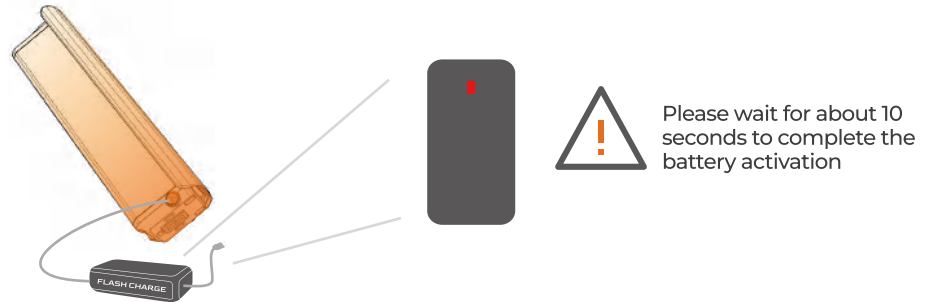

### Why do you need to activate the battery:

We use a more advanced BMS(Battery manage system) to better protect the battery cells and extend the battery life. Therefore, during transportation or when not in use for a period, the BMS(Battery manage system) will automatically enter the sleep mode of the battery.

The judgment conditions for sleep are as follows:

- Battery capacity<1%, enter sleep mode after 10 minutes
- Battery capacity<10%, enter sleep mode after 48 hours
- Battery capacity<40%, enter sleep mode after 14 days
- Battery capacity<80%, enter sleep mode after 30 days
- More than 80% does not automatically enter sleep mode

So if you find that you cannot turn it on after not using it for a long time, please connect the charger to activate the battery first.

## 2. QUICK GUIDE

Before using the product, please follow the installation guide for proper assembly of the corresponding components, verify that all fastening parts are secure, confirm the battery is fully charged, and take appropriate protective measures for riding.

### Step 1: Adjust the handlebar and saddle

Please adjust the handlebar and saddle to the appropriate heights for the rider, and make sure that the seat post quick-release hoop and the stem quick-release hoop are securely fastened.

- Note: For optimal comfort, adjust the handlebar to a height that suits your riding style. The saddle should be set at your pelvic height and must not exceed the maximum safety scale.

### Step 2: Power on and adjust the headlight

1. Turn on the battery's power supply
2. Press the power button for about 2 s; the screen will light up.
3. Press the  for about 2 s to turn the lights on, Adjust the headlight to illuminate the area 10 m ahead.

①



Turn the key and remove the battery



Turn on the switch, turn on the battery, and put it back

②

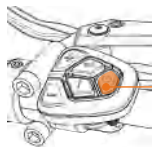

Press for 2 s to power on, and hold for 2 s to power off

③

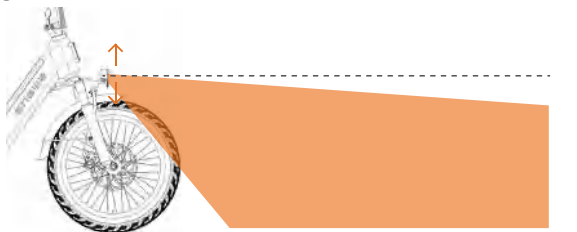

### Step 3: Gear shift

Adjust the ride mode according to road conditions and personal needs. The bike is designed with 5 assist gears. Click the power "+" and "-" buttons to shift between gears.

The 1st gear is suitable for riding on relatively flat roads. As the incline of the road increases, you can shift to a higher gear accordingly. Note: When the bike is in PAS mode and the battery is low, you can still ride it like a regular bike.

Throttle operation is not affected by the PAS level; throttle power remains the same regardless of the selected PAS level.

### Step 4: Ride on the road

Please put on a helmet before riding on the road.

### Step 5: Brake

The left brake is intended for the front wheel, while the right brake is intended for the rear wheel. To brake, first engage the right brake, followed by the left, to slow down the bike until it comes to a complete stop.

- Warning: Avoid abruptly applying the front wheel brake on its own, as this can easily destabilize the bike's center of gravity and lead to a fall.

If the default settings do not meet your needs, you can personalize the settings as follows:

1. Enter the personalized settings: in power-on state, press and hold the buttons **+** and **-** at the same time for more than 2 seconds (see diagram 1);
2. Select a setting: press the buttons **+** or **-** to choose different setting options.
3. Adjust the option: press the **i** button to enter a selected setting, then use the **+** or **-** button to adjust the choices, then press the **i** button again to confirm.
4. Setting descriptions:
  - a. Toggle Unit: switch the mileage unit. (see diagram 1)
  - b. Factory Restore: click **i** to enter reset interface, choose 'yes' and press **i** for 2 seconds to clear all your personal settings. (see diagram 2).
  - c. Pedal Assist Sensor Mode: Select between torque-based assist for a more natural, responsive riding feel (OFF) or cadence-based assist for smooth, consistent assistance (ON). (see diagram 3)
  - d. Brightness: adjust the screen brightness. (see diagram 4)
  - e. Password enable:
    - i. Choose "psd-y" choice to enable the password, and press the buttons **+** or **-** to choose number, kick **i** button to confirm. After 4 numbers confirm, please press **i** for 2 seconds. the correct password must be entered to access the main interface and adjust the assist gear. (see diagram 5)
    - ii. if need to reset your password. Please change password enable from 'psd-y' to 'psd-n', and set password as 4.d.i process again.
5. Exiting setting:
  - a. method 1: press the buttons **+** and **-** for 2 seconds.
  - b. method 2: With no action after 1 minute, display will exit setting interface automatically.



diagram 1

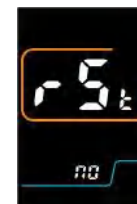

diagram 2

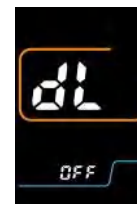

diagram 3



diagram 4

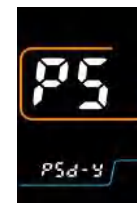
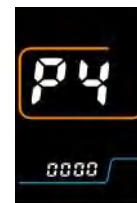

diagram 5



### 3.USER MAINTENANCE INSTRUCTIONS

#### Electrical and Safety Guidelines

1. Do not park or charge the eBike in building entrances, hallways, stairwells, or evacuation routes.
2. Do not charge inside residential buildings. Keep away from flammable materials and avoid charging for more than 12 hours.
3. Do not modify the battery, wiring, lighting, or install unauthorized electrical accessories.
4. Do not touch electrical components with wet hands or metal objects.
5. Do not open electrical parts to avoid liquid or debris entering.
6. Avoid spraying water directly on electrical connectors; do not use a pressure washer.
7. Avoid prolonged exposure to sun or rain to prevent component aging.

#### Riding Safety

1. Riders must be 14 years or older. Do not lend the bike to inexperienced users.
2. Ride in designated bike lanes and follow local speed regulations.
3. Carry passengers or cargo only as allowed by local laws.
4. Always wear a properly fastened helmet.
5. Slow down in rain or snow; avoid riding in severe weather.
6. Follow traffic laws; do not ride under the influence or with improper control.
7. Wear bright, comfortable clothing and suitable footwear.

#### Pre-Ride Checklist

1. Power on, display works, and battery level is sufficient.
2. Front/rear lights and turn signals function correctly; headlight angle is appropriate.
3. Horn works properly.
4. Handlebar position and screws are secure.
5. Brakes are responsive and activate the tail light.
6. Tire pressure and condition are normal, with no sharp objects.
7. Wheel nuts are tight; pedal reflectors are intact.

#### Riding Precautions

1. Accelerate gradually when starting to avoid sudden loss of control.
2. Increase braking distance and ride cautiously on wet or snowy roads to prevent slipping.
3. Shift to a lower gear before stopping to make the next start easier.

#### Pushing and Parking

1. Turn off the power before pushing the bike to avoid accidental throttle activation.
2. Use the walk-assist mode when pushing uphill or when carrying heavy loads.
3. Park the bike on a flat surface, deploy the kickstand, and turn off the power.
4. Clean and maintain the bike regularly to keep it in optimal condition.

#### Storage Instructions

1. Store the eBike in a cool, dry, and well-ventilated area, away from direct sunlight, moisture, and extreme temperatures.
2. Turn off the battery switch before storage.
3. For long-term storage, keep the battery between 50%–80% charge and recharge every 1–2 months.
4. Keep the bike and battery away from flammable or explosive materials.
5. Store the bike and battery out of reach of children.
6. Do not place heavy objects on the bike or battery.



**WARNING:** Repairs must not be performed by untrained personnel. If a malfunction occurs, please contact customer service or visit an authorized service center for assistance.

### Vehicle Maintenance & Self-Check

1. The eBike is fully adjusted before leaving the factory. If you have any doubts, contact the manufacturer or dealer.
2. Check tire pressure regularly and keep it within the recommended range.
3. Routinely inspect major components—handlebar, stem, saddle, axles, bottom bracket, freewheel, chain, and wheels—to ensure smooth operation. Tighten any loose nuts or bolts immediately.
4. Replace worn parts such as brake pads, chain, or tires at a local repair shop. Always use parts of the same model and specifications.

### Motor Maintenance

1. Keep the motor clean and free from foreign objects or corrosive liquids/gases. Do not strike or heat the motor housing.
2. The motor is rated IPX5. Do not spray it with a high-pressure water jet or submerge it in water. If water reaches the hub center, electrical components may short-circuit and become damaged.

### Battery Maintenance

1. Lithium battery lifespan depends heavily on usage habits. Avoid running the battery to very low levels. Charge regularly and do not leave the battery unused for long periods.
2. For initial use, a normal full charge is sufficient. Disconnect the charger once charging is complete.
3. If the bike will not be used for an extended time, charge the battery for about 2 hours every month. Do not store the battery in a fully discharged state, as deep discharge can cause irreversible damage.



**DANGER:** Do not disassemble old batteries yourself. Dispose of them only at government-designated facilities or at our authorized service centers.

**WARNING:** Keep the battery away from open flames and high-temperature heat sources. Do not throw the battery into fire. Do not expose it to direct sunlight during hot weather.

### 3. NOTES FOR MAINTENANCE

#### Troubleshooting

Symptom	Possible cause	Common solution
The bike fails to work	Low battery Poor connection of electrical parts Incorrect start sequence	Charge the battery Clean and re-tighten the connector Start the bike in the correct sequence (see 2.5)
Insufficient range	Insufficient tire pressure Excessive uphill travel, high wind speeds, frequent braking, and overloading The battery is faulty, damaged or aging Poor connection of charger	Check whether the tire leaks and inflate the tire adequately Utilize the pedal for assistance while riding or modify your route accordingly Contact the engwe after-sales team for assistance
The battery fails to be charged	The charger is damaged the battery is stored for a long time and not charged regularly	Reconnect the charger Replace the charger Contact the engwe after-sales team for assistance
The motor fails to work after power-on	The motor cable is loose or damaged The throttle grip is loose or damaged. The motor is damaged	Reconnect or replace the cable Tighten or replace the throttle grip Contact the engwe after-sales team for assistance
Unusual acceleration or excessively low speed	The throttle grip is loose or damaged, or the battery charge is too low	Tighten or replace the throttle grip and fully charge the battery

#### Fault code

The engwe electric bike comes with a fault detection system. If the electrical system fails, the instrument will display a fault code. Here are the most common fault codes to assist you with troubleshooting. If a fault code is displayed, please stop operation immediately and contact the after-sales team of engwe.

Fault code	Symptom		
		E30	Communication fault
E01/E02/E42	Control unit current fault	E31	controller fault
E03	Control unit Hall fault	E36	Torque sensor fault
E05	Control unit temperature fault	E37	Speed sensor fault
E06	Motor temperature protection	E38	Temperature sensor fault
E09	Volt fault	E43	Motor fail fault

### 3.3 TROUBLESHOOTING

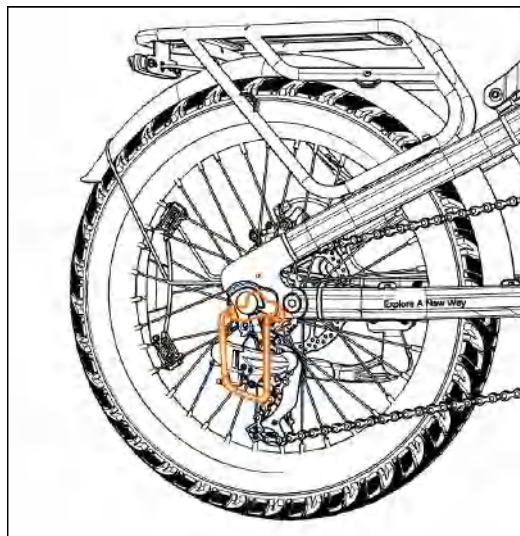

30-35 Nm to tight

**Warning:** Clockwise direction is to tighten, counterclockwise direction is to loosen.

If you need to ride in off-road environments such as mountains, this protection frame is used to protect the rear derailleur from being bumped in extreme riding environments. This protection cage is optional.

If you need to install it, please go to the official after-sales point and use professional tools to install it under the guidance of professionals.

Do not use the tools in the packaging box to install it or install it by yourself, which may cause a series of after-sales problems with the rear wheel and motor.



## 4. SERVICE GUIDE

### Warranty principles

1. The user shall use the product as described in this manual. For any performance failure caused by the product quality, the company will fulfill its warranty obligations according to the provisions of the consumer protection laws;
2. The company is responsible for repairing faults outside the warranty coverage and the main components after the warranty period has expired. However, appropriate charges will apply.
3. For the replacement of the battery beyond the warranty period, the company will provide the battery at the factory cost. However, the corresponding battery must be collected and sent back to the manufacturer to ensure safety and prevent environmental pollution.

### Warranty coverage and duration

Item	Accessory name	Warranty period	Notes for warranty
Basic parts	Frame	12 months	In cases of natural deformation, cracked welds, loose welds, fractures, and other quality issues resulting from substandard manufacturing, the manufacturer will provide replacements in accordance with the warranty terms. Unauthorized modifications, damage from collisions, etc., are not covered under the warranty.
	Fork, handlebar, foldable riser, seat post	12 months	
	Tire	1 month	Tires punctured by sharp objects, parts damaged due to collision, etc. are not covered under the warranty.
	Saddle, brake, brake disc, brake lever	3 months	
	Crank set, pedal, kickstand, mudguard, seat post quick-release hoop, foldable stem quick-release hoop, hub, thumb shifter, rear derailleur, flywheel, chain, bottom bracket, shock absorber	6 months	
Electrical Parts	Control unit, charger, main/auxiliary cables, instrument, throttle grip, torque sensor, battery cover, power-off brake lever	12 months	The manufacturer will make replacement as per the warranty terms for short circuits, burnout, performance failure caused by poor manufacturing, etc.; Water ingress, cable disconnection, man-made damage, etc. are not covered under the warranty.
	Headlight, taillight	6 months	
Motor	Motor core, Hall element, bearing, clutch	12 months	The manufacturer will make replacement as per the warranty terms for problems such as phase loss, burned Hall elements, demagnetization, and abnormal sound of the bearing; Faults such as cable disconnection and water ingress are not covered under the warranty.
Battery	Battery top cover, battery bottom cover, battery case, motor core	12 months	If the battery fails to charge and its capacity is less than 70%, the manufacturer will make replacement as per the warranty terms (the new battery's warranty period will be calculated according to the remaining warranty period, rather than being calculated from the beginning). Faults due to man-made damage are not covered under the warranty.

• Note: The limited warranty does not apply to any subsequent owner or other transferee of the electric bike.

### 4.1 AFTER-SALES SERVICE AND WARRANTY COVERAGE

**Notes for warranty**

1. The accessories will be covered in the warranty in strict accordance with the warranty period;
2. The warranty period starts from the date of purchase;
3. The charger, battery and motor disassembled without authorization will not be covered under the warranty;
4. Other parts of the bike are only covered under the three-month warranty in case of quality problems;
5. When other parts of the bike fail, the maintenance must be carried out at a professional maintenance site. It is not allowed to disassemble and assemble the bike without authorization. The control unit, battery and charger must have intact labels;
6. For repair of the bike, the warranty card, invoice, certificate of conformity and other relevant documents must be presented;
7. The battery shall be subject to a separate warranty, that is, in case of battery problems, the battery shall be returned to the manufacturer to determine whether it is under the warranty coverage according to the battery test, and then the warranty liability shall be carried out accordingly.

**Warranty card**

User	Organization			
	Name		Tel	
Address				
Purchase Date			Color	
Bike Model			Invoice Number	
Frame Number			Motor Number	

**Repair record**

Date	Repair Content	Remarks

## 4.SERVICE GUIDE

---

### Product Parameters

Product model	L20 3.0
Frame material	Aluminum alloy
Maximum load	150KG / 330lbs.
Maximum speed	20mph
Motor torque	90Nm
Battery capacity	48V 14.25Ah
Maximum range	96 KM/60 MI
Tire size	20 x 3" Front / Rear
Tire pressure	Not more than 45 PSI
Charger	54.6V 8A
Charging time	2h
Waterproof rating	IPX4
Bike weight	34.5 kg / 76.1 lbs.
Maximum load capacity of rear rack	25 kg / 55 lbs.

\*The maximum range is measured in 1st gear with full charge and a load of 75 kg on a flat surface at 25°C and a relative humidity of 70%. The actual results may vary due to the differences in gear, temperature, load, wind speed, road conditions and other factors.

---

### 4.3 PRODUCT PARAMETERS



## FCC STATEMENT

1. This device complies with Part 15 of the FCC Rules. Operation is subject to the following two conditions:

- (1) This device may not cause harmful interference, and
- (2) This device must accept any interference received, including interference that may cause undesired operation.

2. Changes or modifications not expressly approved by the party responsible for compliance could void the user's authority to operate the equipment.

NOTE: This equipment has been tested and found to comply with the limits for a Class B digital device, pursuant to Part 15 of the FCC Rules. These limits are designed to provide reasonable protection against harmful interference in a residential installation. This equipment generates, uses and can radiate radio frequency energy and, if not installed and used in accordance with the instructions, may cause harmful interference to radio communications. However, there is no guarantee that interference will not occur in a particular installation. If this equipment does cause harmful interference to radio or television reception, which can be determined by turning the equipment off and on, the user is encouraged to try to correct the interference by one or more of the following measures:

Reorient or relocate the receiving antenna.

Increase the separation between the equipment and receiver.

Connect the equipment into an outlet on a circuit different from that to which the receiver is connected.

Consult the dealer or an experienced radio/TV technician for help.

### FCC Radiation Exposure Statement

This equipment complies with FCC radiation exposure limits set forth for an uncontrolled environment. This equipment should be installed and operated with a minimum distance of 20 cm between the radiator and your body.

**Customer Service Hotline:** +1 844 200 7117 (U.S.)

**Working hours:** 9:00 a.m. – 6:00 p.m. (GMT+1), Monday to Friday

**Official Website:** <https://engwe-bikes.com/>

If you have any questions or suggestions regarding this user manual, please contact us at:

**Email:** [service@engwe-bikes.com](mailto:service@engwe-bikes.com)



APP Download



Assembly video