



*m*1000

1000W (4 ohm and 70V) DSP SUBWOOFER AMPLIFIER

USER MANUAL

V1.8b

IMPORTANT SAFETY INSTRUCTIONS

1. Read these instructions.
2. Keep these instructions.
3. Heed all warnings.
4. Follow all instructions.
5. Do not use this apparatus near water.
6. Clean only with a damp cloth.
7. Do not block any ventilation openings. Install in accordance with the manufacturer's instructions.
8. Do not install near any heat sources such as radiators, heat registers, stoves, or other apparatus (including amplifiers) that produce heat.
9. Do not defeat the safety purpose of the polarized or grounding-type plug. A polarized plug has two blades with one wider than the other. A grounding-type plug has two blades and a third grounding prong. The wide blade or the third prong are provided for your safety. If the provided plug does not fit into your outlet, consult an electrician for replacement of the obsolete outlet.
10. Protect the power cord from being walked on or pinched particularly at plugs, convenience receptacles, and the point where they exit from the apparatus.
11. Only use attachments/accessories specified by the manufacturer.
12. Use only with the cart, stand, tripod, bracket, or table specified by the manufacturer, or sold with the apparatus. When a cart is used, use caution when moving the cart/apparatus combination to avoid injury from tip-over.



13. Unplug this apparatus during lightning storms or when unused for long periods of time.
14. Refer all servicing to qualified service personnel. Servicing is required when the apparatus has been damaged in any way, such as power-supply cord or plug is damaged, liquid has been spilled or objects have fallen into the apparatus, the apparatus has been exposed to rain or moisture, does not operate normally, or has been dropped.
15. The apparatus shall not be exposed to dripping or splashing and that no objects filled with liquids, such as vases, shall be placed on the apparatus.
16. **WARNING:** To reduce the risk of fire or electric shock, do not expose this apparatus to rain or moisture.
17. Where the mains plug or an appliance coupler is used as the disconnect device, the disconnect device shall remain readily operable.
18. **WARNING:** The Class I apparatus shall be connected to a mains socket outlet with a protective earthing connection.

• Descriptions of Graphical Symbols

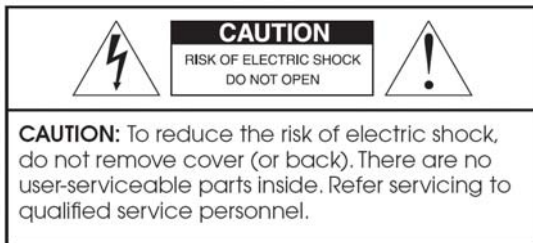

The "lightning bolt" with an "arrowhead" symbol within an equilateral triangle alerts you to the presence of uninsulated "dangerous voltage" within the product's enclosure, and to the fact that such voltage may constitute a risk of electric shock to one or more persons.



The exclamation point within an equilateral triangle alerts you to the presence of important operating and maintenance (servicing) instructions in the literature accompanying the product.

APPLICABLE FOR USA CANADA OR WHERE APPROVED FOR USAGE

CAUTION: TO PREVENT ELECTRIC SHOCK MATCH WIDE BLADE PLUG TO WIDE SLOT INSERT FULLY.

ATTENTION: POUR EVITER LES CHOCS ELECTRIQUES INTRODUIRE LA LAME LA PLUS LARGE DE LA FICHE DANS LA BORNE CORRESPONDANTE DE LA PRISE ET POUSSER JUSQU AU FOND.

INTRODUCTION

The James M1000 is a high performance, class D, subwoofer amplifier capable of delivering a minimum of 1000W of clean power at 4 ohms. It uses advance DSP technology to allow sophisticated optimization of the amplifier's parameters to match the subwoofer being used and the environment in which the subwoofer is installed. The M1000 features a large LCD display and 5 button controller to allow configuration of all DSP settings. On the front panel there are black-out indicators for power, standby, clipping and signal presence. Upon startup, the display will show the firmware revision number. The M1000 is a natural choice for every James subwoofer installation.

INSTALLING RACK MOUNT EARS

If you plan to install your M1000 into a standard 19-inch rack, you must install the supplied rack ears.

- (1) Remove the 6 screws from the sides near the front of the M1000 (3 on each side).
- (2) Using the same screws, attached the supplied rack ears to the M1000. If required, the 4 feet can also be removed at this time by unscrewing the feet mounting screws located in the center of each foot.
- (3) Due to the weight of the M1000, it is recommended that the rear flanges be secured to the rear rack rails. Hardware to do this is not supplied with the amplifier and is specific to the type and depth of rack you are using. You are responsible to source the proper hardware to secure the rear mounting points.

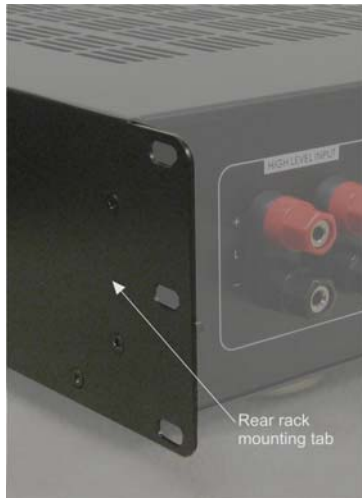

Rear Rack Mounting Tab



Installing Front Rack Ears

CAUTION!

The M1000 amplifier is convection cooled and does not use a fan to eliminate noise and allow it to be used in the listening environment. For this reason, ensure there is adequate ventilation above and below the amplifier when rack mounted. Avoid placing heat generating equipment below it in the rack. If the M1000 does not receive enough ventilation, it may overheat and switch to standby mode.

AC LINE VOLTAGE

The M1000 can be used on 110V-120V, 60Hz or 220v-240V, 50Hz AC lines. To change the operating line voltage:

- (1) Turn the power off using the rear power switch.
- (2) If required, remove the IEC line cord and replace with an IEC AC cable that matches the AC wall socket.
NOTE: This should be a 10A rated cable.

- (3) Remove the plastic cover screws and the plastic cover over the 115/230V selector located on the rear of the amp. Set the switch to the correct position for the line voltage in your country. Check the fuse and install the correct value if needed.

VOLTAGE SELECTOR

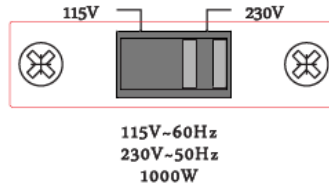

- (4) Replace the plastic cover and screws over the voltage selector switch.
- (5) The M1000 is fuse protected and if you change the AC voltage settings, you also need to change the fuse to the correct value. Use only GDA type fuses. Values are listed below

	115V OPERATION	GDA TYPE 15A 250V
	230V OPERATION	GDA TYPE 8A 250V
<p>REMOVE FUSE HOLDER HERE</p> <p>FUSE:115V,T15AL/250V 230V,T8AL/250V</p> <p>NOTE: A spare fuses is also located in this holder</p>		<p>10mm 20mm (±2.0) (±0.5)</p> <p>5.2mm (+0.1/-0.2)</p>

INSTALLATION - CONNECTIONS

- (1) Attach the audio input cable from your source to the proper input connector(s) on the M1000. Use the high level binding posts if feeding a speaker level signal from the output of an audio amplifier. Use the XLR line level inputs if you have a balanced audio signal coming from your receiver or processor. Use the RCA line level input jacks if using an unbalanced line level source. If feeding the signal from the LFE output from a home theater receiver or processor, you only need to use one cable and connect to either the left or right input since the LFE signal is mono.
- (2) Connect one end of the speaker wire to the speaker output binding posts observing the polarity and connect the other end to the subwoofer terminals.

NOTE: All 5-way binding posts have an insulating plug inserted into the end of the post. If you wish to insert a banana plug as your method of connection, you can insert the banana plug into the wire hole in the binding post, or you can remove the insulators by popping them out with a small screwdriver.



Removing the binding post insulators



Inserting banana plugs into wire holes

- (3) If you haven't done so, verify that the amplifier's AC mains selector on the rear of the M1000 is set to your AC line voltage and you have the correct fuse installed.
- (4) Verify that the rear power switch is in the off position. Plug the power cord into the rear IEC connector on the rear of the amplifier. Connect the other end of the AC cord to an AC power wall socket.
- (5) Once all the input, output and power cables are connected, turn the unit on and proceed with the DSP setup.

REMOTE CONTROL

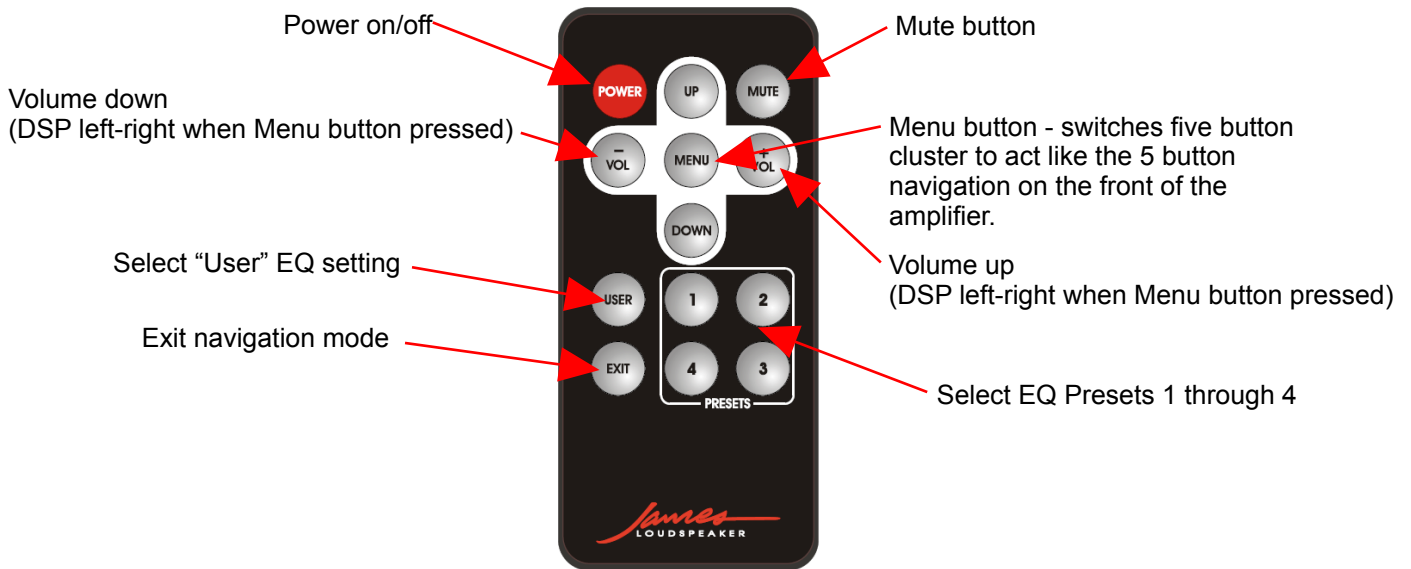

The remote control duplicates the functions of the 5 button controller on the front of the M1000, plus adds some additional functions such as power on/off, mute on/off, and 1 button selection of the 5 EQs. In a typical home theater installation however, the remote will most likely NOT be used as the M1000 will be configured to a specific subwoofer and room placement, and controlled by the main processor or receiver.

IR CODES

For a complete set of codes, please go to our website at www.Jamesloudspeaker.com and download from the M1000 page listed under Products > Electronics > Amplifiers > M1000 Sub-Amp.

FRONT PANEL

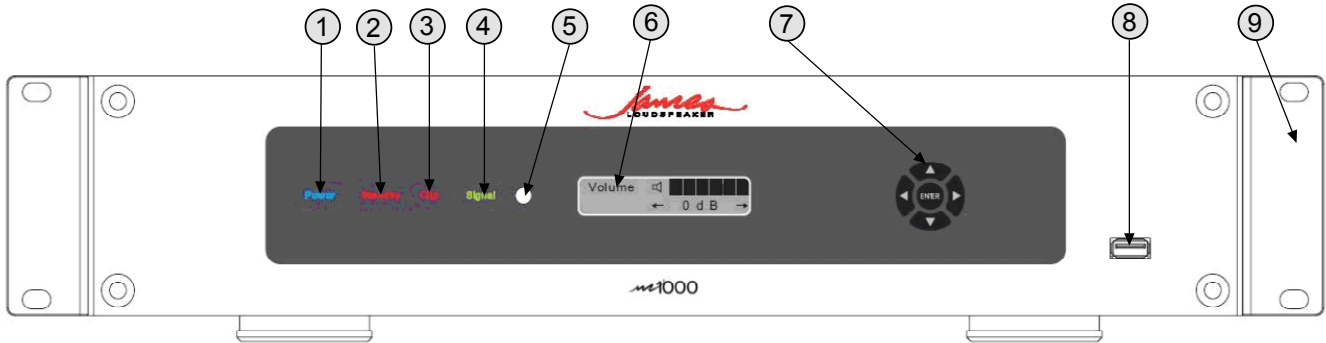

- 1 **Power Indicator** - The word “power” will appear in blue when the unit is powered on and is out of standby mode.
- 2 **Standby Indicator** - The word “Standby” will appear in red when the M1000 is in standby mode. The M1000 is put into Standby Mode by turning the amplifier off through either the remote, the auto off mode or the 12V trigger. Also, if the amplifier overheats, the standby indicator will come on as the amplifier will go into standby mode.
- 3 **Clipping Indicator** - The word “Clip” will flash in red when the power output exceeds the 1000W power rating of the amplifier. Although running the M1000 into clipping is not recommend for sonic and woofer reliability reasons, occasional clipping is generally acceptable on music and movie sources due to their very dynamic nature. However, if any distortion is heard the amplifier level should be reduced.
- 4 **Signal Indicator** - The word “Signal” will flash in green when a signal is present on the inputs.
- 5 **IR sensor/receiver** - IR signals from the remote control are received here. If a IR sensor is plugged into the rear IR input jack, this sensor will be turned off.
- 6 **16 character x 2 row Liquid Crystal Display** - Shows the amplifier’s status, menus and settings and works in conjunction with the 5 button navigation controls and the remote control.
- 7 **5 button programming navigation controls** - Used to scroll through the Display menus, change settings and program the DSP controller.
- 8 **USB Connector** - For uploading new firmware/software.
- 9 **Optional rack ears** - Two rack mount ears for 19-inch rack mounting are provided for rack mounting. The rear mounting holes should also be used for supporting the amplifier in a rack cabinet.

REAR PANEL

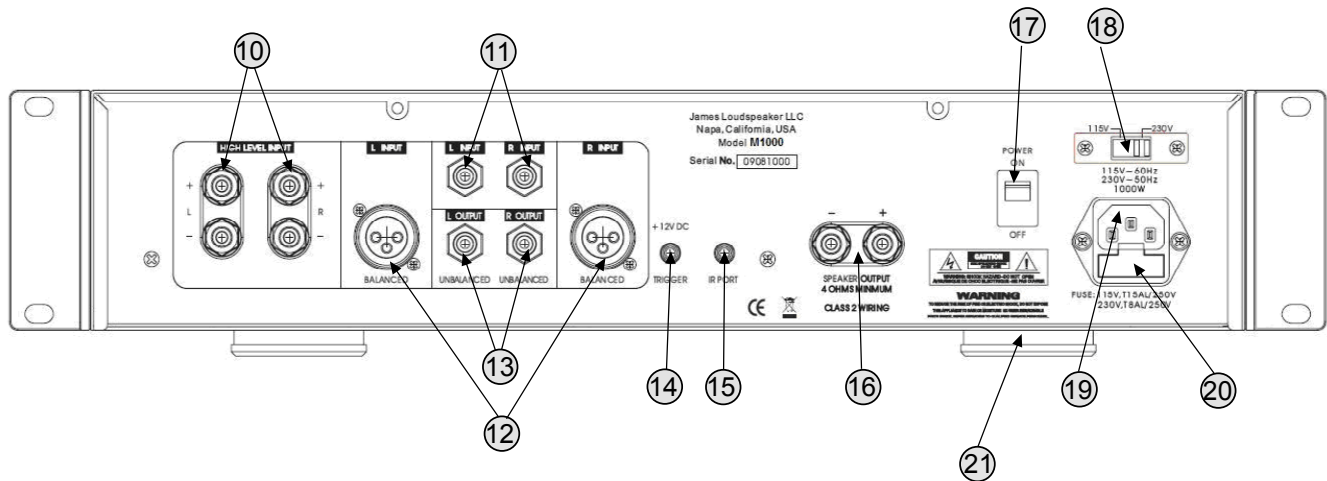

10 Left/right high level inputs - for connecting high level speaker outputs from another amplifier to drive the subwoofer amplifier. Useful for zones where only stereo left/right high level speaker signals are available and a subwoofer needs to be added.

11 Left/right RCA inputs - For feeding line-level stereo left/right signals. Also, either left or right RCA jack can be used for a mono LFE input.

12 Left/right XLR balanced inputs - For feeding BALANCED line-level stereo left/right signals. Also, either left or right XLR jack can be used for a mono LFE input.

13 Left/right RCA outputs - For looping the subwoofer input signal to additional amplifiers. The signal received by the RCA or XLR inputs is passed out through these jacks and is not effected by the amplifier and maintains left/right separation. XLR BALANCED inputs are converted to unbalanced RCA output.

14 12V trigger input (3.5mm) - For triggering the power on/off from other devices such as processors or receivers that have a 12V trigger output. 6V minimum required for triggering.

NOTE: Once in trigger mode, the amplifier cannot be turned on without a 12V trigger signal. To disable the 12V trigger, turn the unit off, then hold down the left and right navigation buttons while turning the amplifier on with the rear power switch. The trigger mode will be turned off and the amplifier will power on.

15 External IR input (3.5mm) - For attaching an external IR receiver. Plugging in an IR receiver here will disable the front panel IR receiver.

16 Speaker 5-way binding posts - Connect your loudspeaker here. Minimum impedance of the load is 4 ohms. Multiple woofers can be connected if the **combined load impedance is 4 ohms or greater**.

17 Power Switch - Turns the amplifier on or off. Amplifier must be on for the trigger or auto sense modes to operate.

18 115V/230V AC mains voltage selector - For switching the operation for 110V-120V, 60Hz or 220V-240V, 50Hz AC line voltages. **NOTE:** when the AC line voltage is changed, the fuse must also be changed to continue to provide protection to the amplifier.

19 IEC Power cable connector - Connect a IEC AC cable here rated for 15A service.

20 Fuse holder - The fuse holder is part of the IEC connector. Use a GDA type fuse as follows: 15A for 115V operation and 8A for 230V operation.

21 Removable feet - The amplifier feet can be removed as required for rack mount installation.

LCD DISPLAY SCREENS/FUNCTIONS

Normally, the LCD display will show the status for a number of DSP settings as well as the volume level and a flashing output level bar display. The “normal” display is show below.

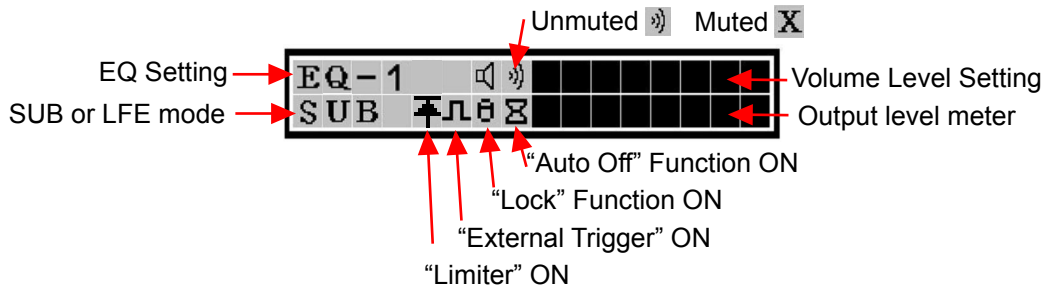

Navigation through the DSP menus and DSP settings are done via the 5 button controller on the front of the M1000 and the 5 button array on the remote control.

Once a limiter setting of anything but “0” is set, the red clip indicator on the front panel, which normally indicates full power clipping, will now light when the limiter maximum power is reached. Also, an up arrow icon will appear on the bottom row of the display to indicate the limiter is turned on.



M1000 Navigation Buttons

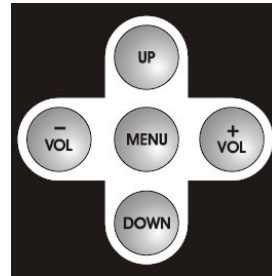

Remote Navigation Buttons

When in the Normal mode, pressing the left/right buttons will allow volume adjustment and the display will change to volume mode (see below).

Pressing the “enter” button will switch to the DSP setting mode and the first screen to appear will be the “Subsonic Freq” display. From that point, the “up” and “down” buttons will scroll through the different setting screens as listed below. The left and right buttons will allow you to set the options for any screen. If you accidentally get to a screen you wish to exit, do not press a button for 3 seconds and display will revert back to the “normal” mode. You can also select the default setting again.

On each DSP display screen, the current DSP default setting will be displayed. If you use the left/right buttons to select a new option for that setting, you must then press “menu” to select this option. When scrolling left/right through the options, the current default will have an asterisk next to it.

Once you have configured all the settings for your product, you can save them as 1 configuration by using the “Memory Store” screen. In this way, if the settings are invariably changed, you can always recall your saved settings in this way. **NOTE:** Avoid storing to the Memory 3 location as this is where James stores the configuration for your subwoofer if it was programmed at the factory.

If James has configured your M1000 for a specific subwoofer, it will be saved in Memory 3 location. This can be overwritten so avoid saving any settings to the memory 3 location unless advised by James personal.

You can always revert to the factory default settings by recalling “default” in the “Memory recall” function.

Following are further explanations of each DSP screen. Also, a flow chart follows this section with further details.

Normal Screen	
	<p>This is the normal operating screen for the DSP and some of the current settings are displayed along with a volume bar and an output level bar meter. (see details above).</p> <p>NOTE: Pressing the Menu button will take you to the first DSP setting, “Subsonic Frequency”. Pressing the left/right buttons will take you to the “Volume” Ssetting screen. The output display can be used to estimate the approximate power output during operation.</p>

Segment	Volts	8ohm Watts	4ohm Watts
Top of segment 8	63	500	1000
Top of segment 7	40	200	400
Top of segment 6	15.5	30	60
Top of segment 5	6.3	5	10
Top of segment 4	2.5	1.5	1.5
Top of segment 3	1.0	0.125	0.25
Top of segment 2	0.4	0.02	0.04
Top of segment 1	0.16	0.0035	0.007

Volume Control	
	<p>The “Volume” control is available from the “Normal” screen and is activated by pressing the left/right pushbuttons. This feature allows you to adjust the output volume of your subwoofer amplifier and ultimately, the output of your subwoofer. The volume should be set to achieve the best balance between the main speakers and the subwoofer. After 5 seconds, display will revert back to Normal. Use “left” and “right” push buttons to set.</p>

Subsonic Freq	
	<p>The “Subsonic Freq” setting allows you to limit the low frequency range of the sub and is generally used to protect subwoofers from over-excursion and/or damage from operating below the subwoofer’s tuning frequency. A “flat” setting is provided to remove the fliter, or a filter frequency can be set from 16Hz to 40Hz in 1 Hz steps. Use “left” and “right” push buttons to set and “menu” to save.</p>

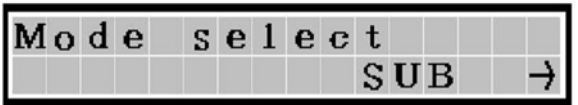
Mode Select	
	<p>The “Mode Select” allows switching the amplifier between LFE or SUB mode. In LFE mode, the crossover slope and frequency adjustments are disabled. The crossover frequency should then be set by an external processor/receiver. Use “left” and “right” push buttons to set and “menu” to save.</p>

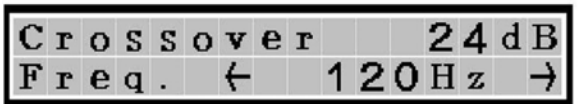
Crossover Freq	
	<p>ONLY AVAILABLE WHEN IN SUB MODE.</p> <p>The “Crossover Freq” setting allows the crossover frequency to be set from 40 to 160 Hz in 1 Hz increments. For reference, the crossover slope is displayed in the upper right hand corner. Use “left” and “right” push buttons to set and “menu” to save.</p>

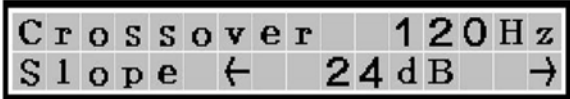

<p>Crossover Slope</p> 	<p>ONLY AVAILABLE WHEN IN SUB MODE.</p> <p>This “Crossover Slope” setting allows the crossover slope to be set from 6 dB/octave 36 dB/octave in 6 dB/octave increments. The higher the slope, the less mid-band information will get through to the subwoofer, but there will be greater phase change which might effect the sound of the system as a whole.</p> <p>For reference, the crossover frequency is displayed in the upper right hand corner.</p> <p>Use “left” and “right” push buttons to set and “menu” to save.</p>
---	---

<p>EQ Mode</p> 	<p>The “EQ mode” setting allows six selections</p> <ul style="list-style-type: none"> - “Flat” removes any EQ and provides flat frequency response. - “User” setting allows the user to adjust and program a personal EQ curve. - The 4 presets (EQ1 to EQ4) are factory presets and should only be used when instructed by the factory. <p>NOTE: James may rename any Preset EQ to a specific James Model of subwoofer.</p> <p>Use “left” and “right” push buttons to set and “menu” to save.</p>
---	---

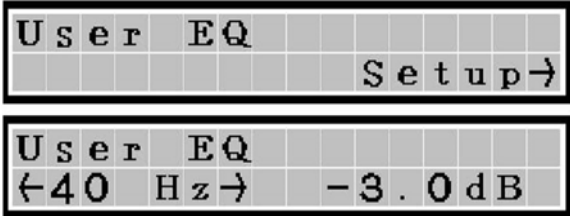
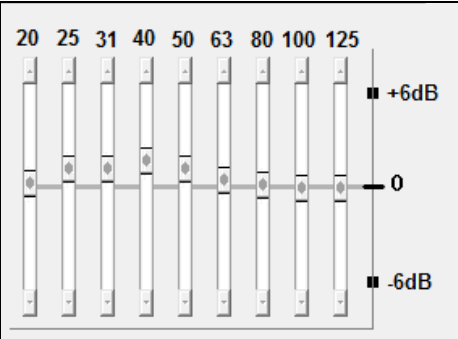
<p>User EQ Setup</p> 	<p>ONLY AVAILABLE WHEN IN USER MODE.</p> <p>In “User EQ” mode, the user can adjust and program nine 1/3 octave bands from 20 Hz to 125 Hz. (20, 25, 31, 40, 50, 63, 80, 100, 125 Hz) by using the left/right pushbuttons. At each frequency, there is a +6 to -6 dB level adjustment in 0.5 dB steps and can be adjusted by pressing the up/down pushbuttons. This feature duplicates a typical third-octave equalizer as show below.</p> 
--	--

<p>Phase Setting Select</p> 	<p>The “Phase” setting is used to adjust the phase/polarity of the subwoofer to provide the best summing to the main speakers. The physical placement and distance of the subwoofer in relation to the main speakers may result in unwanted cancelation of some of the bass and can be compensated for by adjusting the phase setting.</p> <p>The phase setting can be adjusted while listening for maximum or best bass performance or by using a real time analyzer and measuring the actual response of the system as a whole.</p> <p>The phase adjustment is in 45 degree steps from 0 to 315 degrees.</p> <p>Use “left” and “right” push buttons to set and “menu” to save.</p>
--	---



Limiter	
 <p style="text-align: center;">Limiter On</p>	<p>The limiter function allows setting the maximum power which will be supplied by the M1000. This is useful for preventing over-powering smaller subwoofers. Like most audio amplifiers, the M1000 is a voltage amplifier and delivers voltage to the load. But the actual power depends on the impedance of the load, so the limiter is set by -dB, which are independent of actual power but indicate level reductions. The load on the M1000 can be 1 or 2 subwoofers, as long as the total impedance remains 4 ohms or higher. The limiter is set in -dB, which is the dB from full power which at 4 ohms, is 1000 watts, but only 500 watts at 8 ohms. A -3dB reduction is half the power so 3dB changes are bolded in the table since they are an easy reference point.</p> <p>Once a limiter setting of anything but “0” is set, the limiter icon appears on the display (see illustration) and the red clip indicator on the front panel, which normally indicates full power clipping, will now light when the limiter maximum power is reached.</p>

Limiter setting (dB)	% of max	8ohm Watts	4ohm Watts
0	100%	500	1000
-1dB	79%	397.2	794.3
-2dB	63%	315.5	631.0
-3dB	50%	205.6	501.2
-4dB	40%	199.1	398.1
-5dB	32%	158.1	316.2
-6dB	25%	125.6	251.2
-7dB	20%	99.8	199.5
-8dB	16%	79.2	158.5
-9dB	13%	62.9	125.9
-10dB	10%	50.0	100.0
-11dB	8%	39.7	79.4
-12dB	6%	31.5	63.1

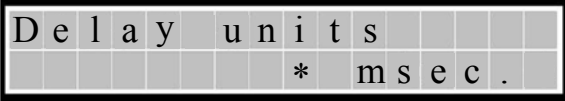
Delay msec	
	<p>The delay feature allows delaying the sub signal up to 30 msec or approximately 30 ft. This is useful for aligning arrival times of rear subwoofers with the front subwoofers. The “Delay msec” feature displays the actual delay setting which will be in the “units” as set in the previous menu item.</p>

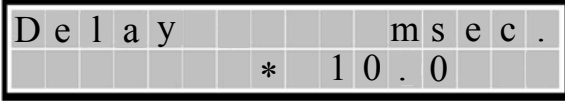
Delay Units	
	<p>The delay feature allows delaying the sub signal up to 30 msec or approximately 30 ft. This is useful for aligning arrival times of rear subwoofers with the front subwoofers. The “Delay Units” feature is set to msec, feet or meters, use whichever unit you are most comfortable working in.</p>

Display Setting	
	<p>The “Display” setting has 2 options to control the LCD display brightness, ON and 30 seconds. When set to “On”, the LCD display is always illuminated. When set to 30 seconds, the display back light will turn off after 30 seconds if no button is pressed.</p> <p>Use “left” and “right” push buttons to set and “menu” to save.</p>

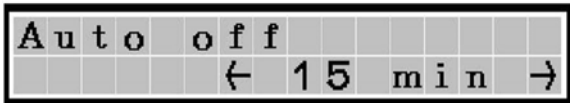
<p>Auto Off Setting</p> 	<p>The “Auto Off” setting allows the amplifier to turn on and off based on the presence of an audio signal. When set to “off”, the function is disabled and the amp stays on constantly. When set to ON, the amplifier is controlled by the presence, or absence, of audio signal on the input jacks. When an input signal is present, the amplifier will turn on immediately. Once the signal stops, the amplifier will turn off after the selected time duration. There are duration settings from 5 minutes to 30 minutes in 5 minutes increments. Typically this is used with a receiver which does not have a 12V trigger. Use “left” and “right” push buttons to set and “menu” to save.</p>
--	---

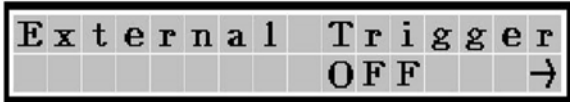
<p>External Trigger Select</p> 	<p>The “External Trigger” setting is used to allow an external 12V trigger source to turn the amplifier on and off with a 12V trigger from another device, such as a processor or receiver. NOTE: Once this feature is selected, the amp will stay in standby mode until 12V is applied to the 12V trigger jack on the rear of the amplifier. This means you cannot TURN OFF the feature unless the amp is on and the amplifier can only be on with a 12V trigger signal applied. However, it is possible to bypass the need for the trigger signal and turn the amp on by doing a special power-on sequence as follows:</p> <ol style="list-style-type: none"> (1) Turn the amp off, (2) Push and hold the left and right pushbuttons on the DSP navigation control, (3) While holding the buttons turn the amplifier on with the rear power switch. <p>The amp will power on with the external trigger turned off. Use “left” and “right” push buttons to set and “menu” to save.</p>
---	--

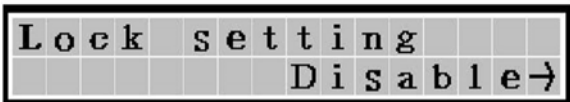
<p>Lock Setting</p> 	<p>The lock setting allows the user to lock the DSP settings in memory and prevent adjustment via the DSP pushbutton controls. To lock, set to “Enable”. To turn off the lock, set to “Disable”. Use “left” and “right” push buttons to set and “menu” to save.</p>
--	---

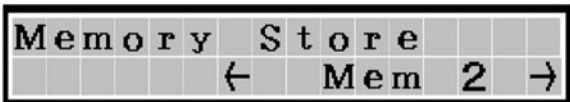
<p>Memory Store Function</p> 	<p>There are 3 independent memories which can be used to save all the DSP settings as a single configuration. Once you have finished programming all the features, select a memory location (1, 2 or 3) and press Menu to save. NOTE: memory 3 is used by James to store settings in some cases so avoid using this location unless you are certain there is no James setting saved there, Use “left” and “right” push buttons to set and “menu” to save.</p>
---	--

<p>Memory Recall Function</p> 	<p>There are 4 memory locations that store 4 independent DSP settings. Memories 1, 2 and 3 are programmed by the user using the “Memory Store” function. A 4th setting, “Default”, resets all the settings back to the factory default. NOTE: Memory 3 is sometimes used by James to store settings for a specific product.</p>
--	--

Default Settings	
MENU ITEM	DEFAULT SETTING
Subsonic filter (Freq)	20 Hz
Subsonic filter (Slope)	24dB/octave
EQ	Flat
Phase	0 Degrees
Limiter	0dB (off)
Delay Units	msec
Delay	0
Display	On
Auto Off	15 Mins
Mode	SUB
Ext Trigger	Off
Lock	Off
Volume	-30dB

DSP MENU TREE

START/NORMAL SCREEN

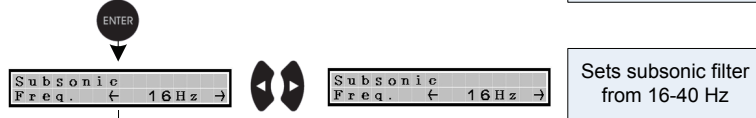
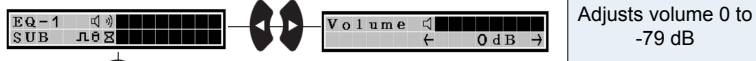

Navigation through the display menus is Accomplished by the 5 button control pads on the front panel of the M1000.



If no button is pressed for 3 seconds, the display reverts back to "normal".

If LFE mode

If SUB mode

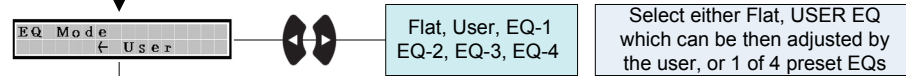
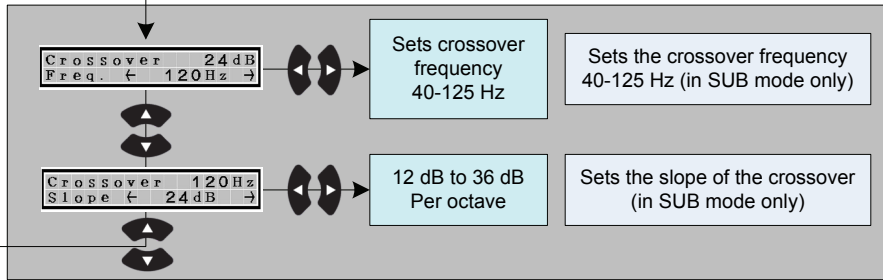

If EQ-1 to EQ-4 or default

If USER

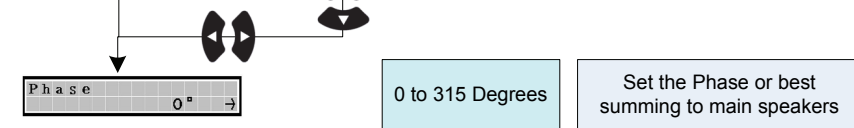
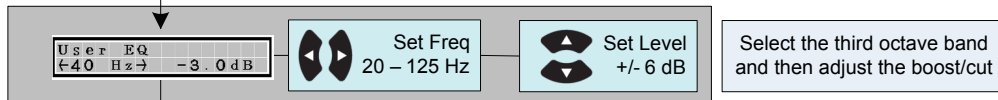

<div style="border: 1px solid black; padding: 2px; width: fit-content;"> Limiter * 0.0dB </div>		0dB to -12dB, 1 dB steps	
<div style="border: 1px solid black; padding: 2px; width: fit-content;"> Delay units * msec </div>		Feet, meters, msec	
<div style="border: 1px solid black; padding: 2px; width: fit-content;"> Delay msec * 10.0 </div>		0-30ft (or meters or msec) 0.1 msec steps	
<div style="border: 1px solid black; padding: 2px; width: fit-content;"> Display On → </div>		ON or 30 Sec	Set the display to be permanently on, or to turn off after 30 secs of inactivity
<div style="border: 1px solid black; padding: 2px; width: fit-content;"> Auto off ← 15 min → </div>		Disable to 30 min	Turns signal sense auto off, or on from 5 to 30 mins
<div style="border: 1px solid black; padding: 2px; width: fit-content;"> Mode select SUB → </div>		SUB or LFE	Sets mode to LFE (no crossover) or SUB (turns on crossover adjustment menus)
<div style="border: 1px solid black; padding: 2px; width: fit-content;"> External Trigger OFF → </div>		On or OFF	Sets 12V trigger mode on or off. To cancel trigger mode
<div style="border: 1px solid black; padding: 2px; width: fit-content;"> Lock setting Disable → </div>		On or OFF	Set lock mode on or off – on prevents adjusts
<div style="border: 1px solid black; padding: 2px; width: fit-content;"> Memory Store ← Mem 2 → </div>		Mem 1, Mem 2 Mem 3	Save all settings to 1 of 3 memory locations
<div style="border: 1px solid black; padding: 2px; width: fit-content;"> Memory Recall ← Mem 2 → </div>		Mem 1, Mem 2 Mem 3, Default	Recalls saved settings from 1 of 4 memory locations

To cancel "12V trigger mode" - power the unit off



push and hold the left and right buttons while turning the power on.



M1000: 1000W DSP SUBWOOFER 4/8 OHM and 70V AMPLIFIER SPECIFICATIONS

GENERAL FEATURES

- High Efficiency, Class D, 1000W RMS (4 ohms) output stage
- DSP signal control for precise adjustment and configuration of the audio signal
- 16x2 character LCD display
- 5 button user interface
- left/right XLR Balanced inputs, RCA unbalanced inputs, and high level binding post inputs for integration into all systems
- 1 set 5-way binding posts for speaker output connection.
- left/right RCA unbalanced "loop-through" outputs for connecting additional amplifiers and electronics
- 12V trigger input
- 115/230V switchable power supply
- Lock-out mode to prevent accidental changes to settings
- Ability to save 3 separate set-up configurations to memory

DSP FEATURES

Volume:	Adjustable, 0 to -79dB in 44 steps
Subsonic Filter:	Adjustable 24dB/Octave 16-40 Hz, 1 Hz increments
Crossover Frequency:	Adjustable 40-160Hz, 1 Hz increments
Crossover Slopes:	Adjustable 12dB-36dB/octave, 6 dB increments
User EQ:	9 independent third-octave frequencies (20 Hz -125 Hz) with +/-6dB range in 0.5 dB increments
4 factory Preset EQ settings:	Application dependent
Limiter:	Up to 12dB of power reduction in 1dB steps
Delay:	Up to 30 msec of delay (in selectable msec, feet or meter units)
Phase:	Adjustable 0-315 degrees, 45 degree increments
Mode:	Sub (crossover) or LFE
Display Mode:	display on, or off after 30 sec of inactivity
Memories:	3 configuration memories for settings.

SPECIFICATIONS

Nominal Power output (4 ohms):	1000WRMS <1% THD
Typical Power Output (4 ohms):	1080WRMS <1% THD
THD @1000W (4 ohms)	0.07%
THD @1W (4 ohms)	0.08%
Frequency Response	
Sub mode:	10-160 Hz (subsonic and crossover adjustable)
LFE mode:	10- 2 kHz (Subsonic adjustable)
S/N ratio:	100dB Sub/ 90dB LFE
Output Noise:	1.5mV Sub/ 2mV LFE
Input Sensitivity (for 1000W out)	
RCA In:	220 mV
XLR In:	220 mV
High Level In:	2.6V
Line out:	200mV (approx 0 dB gain)
Auto-on Sensitivity:	3.2 mV
Auto-off time:	Adjustable 5 - 30 mins, 5 mins steps
12V trigger:	6V DC @ 2ma minimum required to trigger
Power Requirements:	115V/15A max or 230V/7.5V max
Standby Power:	<0.5W
Dimensions (Height):	4" (101.5mm) with feet, 3.5" (89 mm) without feet
(Width):	19" (483 mm) with rack ears, 16.75" (425.5 mm) without rack ears
(Depth):	14.25" (368.5 mm)
Net Weight:	26.5 lbs (12 kg)
Shipping Weight:	34 lbs (15.5 kg)

APPENDIX A – PRESET EQ CURVES

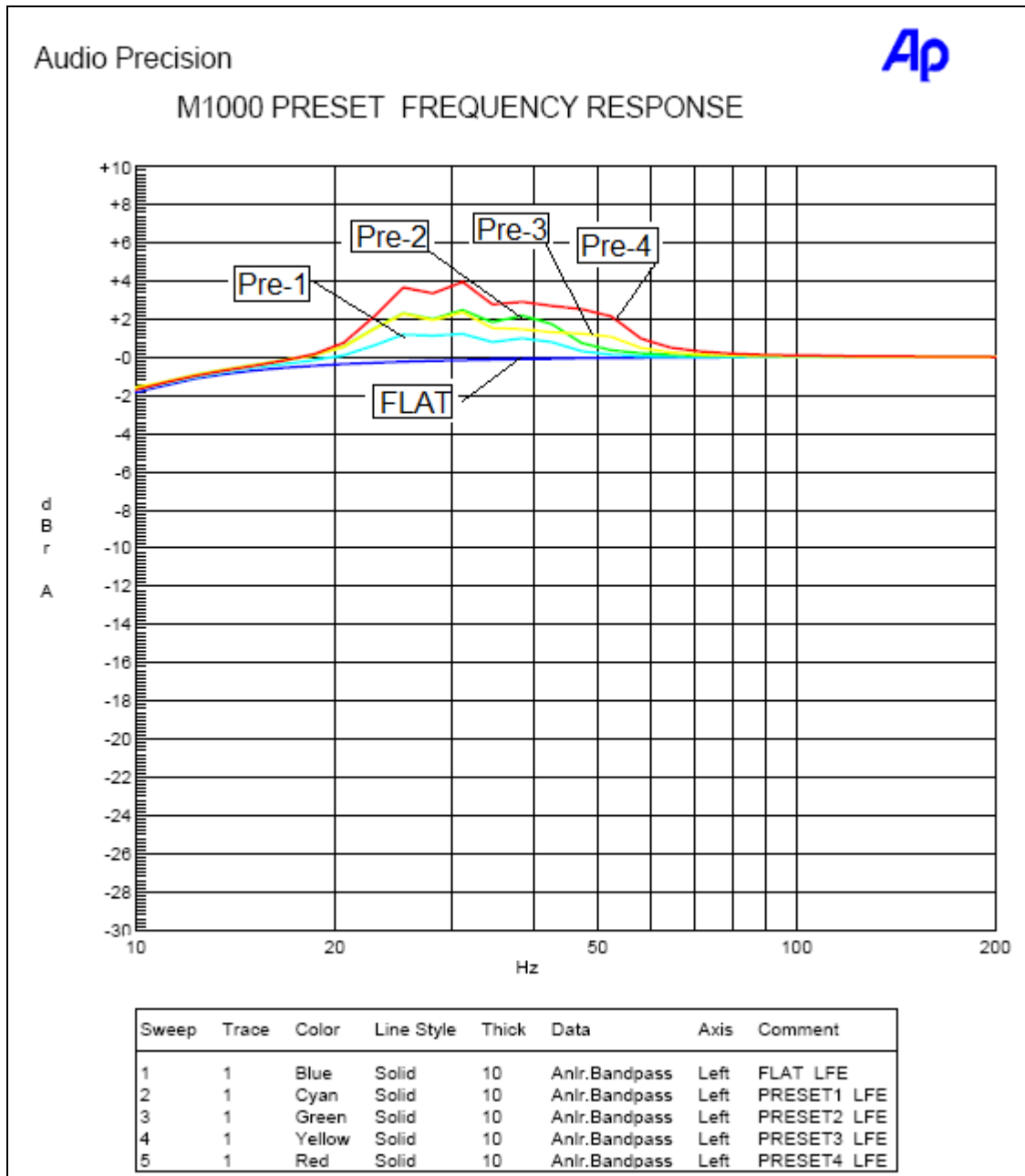

To reprogram any Preset EQ, use the following settings

	20 Hz	25 Hz	31 Hz	40 Hz	50 Hz	63 Hz	80 Hz	100 Hz	125 Hz
Preset 1	0 dB	1 dB	1 dB	1 dB	0 dB	0 dB	0 dB	0 dB	0 dB
Preset 2	0 dB	2 dB	2 dB	2 dB	0 dB	0 dB	0 dB	0 dB	0 dB
Preset 3	0 dB	2 dB	2 dB	1 dB	1 dB	0 dB	0 dB	0 dB	0 dB
Preset 4	0 dB	3 dB	3 dB	2 dB	2 dB	0 dB	0 dB	0 dB	0 dB



APPENDIX B – Thermal and Power Input Data

THERMAL AND POWER INPUT DATA

IDLE POWER, NO SIGNAL INPUT

Voltage	Watts	Amps	VA	BTU'S	Calories
108	21	0.277	29.92	71.61	18060
115	23	0.291	33.47	78.43	19780
120	24	0.297	35.64	81.84	20640
132	28	0.315	41.58	95.48	24080

WATT = 3.41 BTU
WATT = 860 Calories

Standby W	10.7 W
Standby W	0.5W
Idle W	24 W
Line V	120 V
Line Freq	60 Hz

Serials BEFORE 1206xxxx
Serials starting with 1206xxxx and AFTER

WATTS OUT			INPUT POWER				HEAT OUTPUT LEVELS	
SINE WAVE	LOAD	W	@120V AMPS	@240V AMPS	VA	BTU'S	CAL	
85 W	(1/8 power)	8 ohm	115	1.47	0.735	176 VA	102.3	25800
225 W	(1/3 power)	8 ohm	273	3.23	1.615	388 VA	163.7	41280
675 W	(full power)	8 ohm	847	9.05	4.525	1086 VA	586.5	147920
128 W	(1/8 power)	4 ohm	170	2.08	1.04	250 VA	143.2	36120
342 W	(1/3 power)	4 ohm	432	4.87	2.435	584 VA	306.9	77400
1024 W	(full power)	4 ohm	1406	14.92	7.46	1790 VA	1302.6	328520

Generally accepted power levels for thermal and power consumption calculations are 1/8W power input into the expected subwoofer impedance. 1/8 power approximates usage with little or no clipping of the amplifier and distortion free operation. 1/3 power equates to severe amp clipping and audible distortion.



APPENDIX C – TROUBLESHOOTING

1) THE AMPLIFIER APPEARS TO HAVE NO POWER (NO LEDs COME ON)

There are a few obvious things to check. Make sure the amp is plugged in to an active AC power receptacle and if it is a switched outlet, make sure the power is turned on. Make sure the rear power switch is turned on.

Once you have confirmed the AC power is turned on, make sure the voltage selector on the rear of the amp is set correctly. Having the selector at 230V while plugged into an 115V outlet will keep the amp from turning on.

Check the fuse located in the IEC power receptacle.

2) THE AMPLIFIER WILL NOT COME OUT OF STANDBY MODE

If the amp was configured to use the 12V trigger, it will only turn on when a 12V trigger signal is applied to the 12V trigger input. If you are not using a 12V trigger, then you can reset the 12V trigger to “off” by turning the amplifier off, and then turning the amplifier on while holding down the left and right front panel navigation buttons.

The amp could have overheated. Let the amp cool down.

The amp might have suffered an internal component failure. The amplifier will need to be serviced.

3) THE AMPLIFIER IS ON BUT THERE IS NO SOUND FROM THE SUBWOOFER

Check the front panel to see if the green “Signal” indicator is on or flashing. If so, this indicates a signal is going into the amp. So the problem will be between the speaker output from the amp and the subwoofer, most likely an open or shorted speaker wire, or a poor connection at either location, or a bad subwoofer.

Make sure the volume is turned up on the amplifier.

If the green signal indicator does not come on or flash, then there is no signal entering the amp and you should check the cables running into the amp inputs and the source feeding the signal to the amplifier.

If the amplifier is on, but the red standby indicator is on, check the issues listed in item 2.

4) THE AMPLIFIER PRODUCES A BUZZ/HUM IN THE LOUDSPEAKER

Any buzzing or hum that does NOT change level with the volume control is generally caused by a ground loop condition. This is especially common when the M1000 is located on a different AC line from the other equipment or when all the electronics are rack mounted so the chassis's are all grounded via the metal rack. Though using a ground lift adapter on the amplifier's AC plug may cure the buzz/hum issue, removing the ground may result in an unsafe condition if the amp was to experience a power supply failure. We suggest the use of a ground input isolator such as the Radio Shack “Ground Loop Isolator”, part number 270-054. An input isolation transformer can also be used.

If the buzz/hum changes with the volume level, it can still be caused by a ground loop and this should be checked. But also, the buzz/hum could be caused by a bad input cable, so a cable swap is recommended.

5) NO OUTPUT ON THE RCA LOOP THROUGH RCA JACKS

If you are feeding your signal into the XLR inputs, the initial production run of M1000's did not feed the XLR outputs to the RCA loop out jacks. So you will need to use the RCA inputs for these models. This applies to any serial number starting with 0910.

6) AMP DOES NOT APPEAR TO GET LOUD ENOUGH YET THE CLIP LIGHT IS ON

Check to see if the limiter has been set to a low power level.

LIMITED WARRANTY

James Loudspeaker (“James”) warrants to the original retail purchaser (“Purchaser”) only that the James Product (the “Product”) is to be free from defects in materials and workmanship for a period as listed below for each product category:

Product Type	Years
Indoor loudspeaker systems (excluding electronics)	10
Indoor Subwoofers (excluding electronic components)	10
Outdoor loudspeaker systems (excluding electronics)	5
Marine loudspeaker systems (excluding electronics)	2
All electronic components (amplifiers, DSP, remotes, etc.)	2

Though James does not require a Proof of Purchase to be supplied with the returned Product, it is the Purchaser’s responsibility to have available and, if requested by James, to provide a Proof of Purchase before warranty status is determined. If no Proof of Purchase is available when requested, James has the option of rejecting any and all warranty repair claims and/or requests for the Product.

If the Product model is no longer available and cannot be repaired effectively or replaced with an identical model, James, at its sole discretion may replace the unit with a current model of equal or greater performance. In some cases, modification to the mounting surface may be required where a new model is substituted. James assumes no responsibility or liability for such modification. James’s maximum liability is limited to the repair or replacement of the Product only.

Any Product being returned to James for warranty service must have an RMA# clearly marked on the outside of the shipping container. Please call James prior to shipping the product to obtain an RMA#.

Freight collect shipments will be refused. The Product must be shipped in the original shipping container or its equivalent; in any case the risk of loss or damage in transit is to be borne by the Purchaser. James recommends all shipments be properly insured. Product(s) replaced or repaired under this Warranty will be returned, within a reasonable time, freight collect. However, for any Product that is deemed to be under warranty and to have failed within 60 days from the date of purchase, James will pay nominal ground shipping charges both from and to the Purchaser for locations within the contiguous United States.

Limitations:

- This limited warranty does not include service or parts to repair damage caused by improper installation, accident, misuse, abuse, neglect, mishandling, commercial use, wear from ordinary use or environmental deterioration, inadequate packing or shipping procedures, voltage in excess of the rated maximum of the unit, cosmetic appearance of cabinetry not directly attributable to defects in materials or workmanship, or service, or repair or modification of the Product which has not been authorized by James.
- This limited warranty does not cover cosmetic damage, including paint damage, or consequential damage to other components or premises which may result for any reason from the failure of the product.
- This limited warranty is null and void for products not used in accordance with James Loudspeaker’s instructions.
- This limited warranty is null and void for products not purchased from, or installed by, an authorized James dealer as appointed by James.
- This limited warranty terminates if you sell or otherwise transfer this product to another party.
- Determination of warranty status will be at the sole discretion and determination of James.

This Warranty is in lieu of all other expressed Warranties. If this Product is defective in material or workmanship as warranted above, your sole remedy shall be repair or replacement as provided above. In no event will James be liable to the Purchaser for any incidental or consequential damages arising out of the use or inability to use the Product, even if James has been advised of the possibility of such damages, or for any claim by any other party. Some states do not allow the exclusion or limitation of consequential damages, so the above limitation may not apply. All implied warranties on the Product are limited to the duration of this expressed Warranty. Some states do not allow limitation on how long an implied Warranty lasts, so the above limitations may not apply. This Warranty gives the purchaser specific legal rights, and the purchaser also may have other rights which vary from state to state.

JAMES LOUDSPEAKER, LLC.
2185 Park Place
Minden, NV 89423
Phone: +1.775.461.7500 | Fax: +1.775 461.7599
www.JamesLoudspeaker.com

V1.8b