

Refrigerator

use & care

Introduction	2	Storage Features.....	24
Important Safety Information	3	Storing Food and Saving Energy	30
Features.....	6	Normal Operating Sounds.....	31
Installation	7	Filter Replacement	32
Door Removal.....	10	Care and Cleaning	34
Water Supply Connection	13	Troubleshooting	36
Controls and Settings.....	15	Limited Warranty	41
Ice Maker	20		

Welcome to our **family**

Thank you for bringing Frigidaire into your home! We see your purchase as the beginning of a long relationship together.

This manual is your resource for the use and care of your product. Please read it before using your appliance. Keep it handy for quick reference. If something doesn't seem right, the troubleshooting section will help you with common issues.

FAQs, helpful tips and videos, cleaning products, and kitchen and home accessories are available at Frigidaire.com.

We are here for you! Visit our website, chat with an agent, or call us if you need help. We may be able to help you avoid a service visit. If you do need service, we can get that started for you.

Let's make it official! Be sure to register your product.

Keep your product info here so it's easy to find.

Model Number _____

Serial Number _____

Purchase Date _____

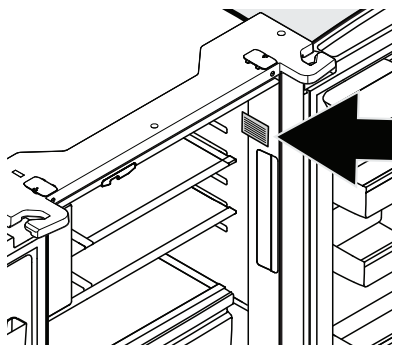

Serial Number Location



Installation Checklist

Doors

- Door seals completely to cabinet on all sides

Leveling

- Refrigerator is level side-to-side and slightly elevated in front to assist with door and drawer closing (front should be higher than back)
- Cabinet is setting solid on all corners

Electrical Power

- House power turned on
- Refrigerator plugged in

Ice Maker

- House water supply connected to refrigerator (**WARNING: Potable water supply only.**)
- No water leaks present at all connections - recheck in 24 hours
- Ice maker is turned ON
- Ice & water dispenser operates correctly

Final Checks

- Shipping material removed
- Fresh food and freezer temperatures set
- Registration card sent in



WARNING

Please read all instructions before using this refrigerator.

Safety Definitions



This is the safety alert symbol. It is used to alert of potential personal injury hazards. Obey all safety messages that follow this symbol to avoid possible injury or death.



DANGER

DANGER indicates an imminently hazardous situation which, if not avoided, will result in death or serious injury.



WARNING

WARNING indicates a potentially hazardous situation which, if not avoided, could result in death or serious injury.



CAUTION

CAUTION indicates a potentially hazardous situation which, if not avoided, may result in minor or moderate injury.



IMPORTANT

IMPORTANT indicates installation, operation or maintenance information which is important but not hazard-related.



DANGER



DANGER Risk of fire or explosion. Flammable refrigerant used. Do not use mechanical devices to defrost refrigerator. Do not puncture refrigerant tubing.

DANGER Risk of fire or explosion. Flammable refrigerant used. To be repaired only by trained service personnel. Use only manufacturer-authorized service parts. Any repair equipment used must be designed for flammable refrigerants. Follow all manufacturer repair instructions. Do not puncture refrigerant tubing.



CAUTION



CAUTION Risk of fire or explosion. Dispose of refrigerator properly in accordance with the applicable federal or local regulations. Flammable refrigerant used.

CAUTION Risk of fire or explosion due to puncture of refrigerant tubing. Follow handling instructions carefully. Flammable refrigerant used.



WARNING

CALIFORNIA RESIDENTS ONLY
Cancer and Reproductive Harm
www.P65Warnings.ca.gov

4

IMPORTANT SAFETY INFORMATION

Child Safety

Destroy or recycle the carton, plastic bags, and any exterior wrapping material immediately after the refrigerator is unpacked. Children should **NEVER** use these items to play. Cartons covered with rugs, bedspreads, plastic sheets or stretch wrap may become airtight chambers, and can quickly cause suffocation.

Safety Instructions

- DO NOT store or use gasoline, or other flammable liquids in the vicinity of this or any other appliance. Read product labels for warnings regarding flammability and other hazards.
- DO NOT operate the refrigerator in the presence of explosive fumes.
- Avoid contact with any moving parts of automatic ice maker.
- Remove all staples from the carton. Staples can cause severe cuts, and also destroy finishes if they come in contact with other appliances or furniture.



WARNING

Do not use electrical appliances inside the food storage compartments of the appliance unless they are of the type recommended by the manufacturer.

Proper Disposal of your Appliance

Risk of child entrapment

Child entrapment and suffocation are not problems of the past. Junked or abandoned refrigerators or freezers are still dangerous – even if they will sit for “just a few days”. When disposing of an old refrigerator or freezer, please follow the instructions below to help prevent accidents.

We strongly encourage responsible appliance recycling/disposal methods. Check with the utility company or visit energystar.gov/recycle for more information on recycling an old refrigerator.

Before disposing of an old appliance:

- Remove doors.
- Leave shelves in place so children may not easily climb inside.
- Have refrigerant removed by a qualified service technician.

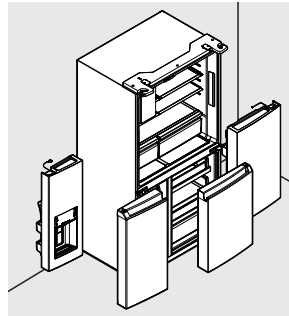

Electrical information

- The refrigerator must be plugged into its own dedicated 115 Volt, 60 Hz., 15 Amp, AC only electrical outlet. The power cord of the appliance is equipped with a three-prong grounding plug for protection against electrical shock hazards. It must be plugged directly into a properly grounded three prong receptacle. The receptacle must be installed in accordance with local codes and ordinances. Consult a qualified electrician. Do not use an extension cord or adapter plug.
- If the power cord is damaged, it should be replaced by an authorized service technician to prevent any risk.
- Never unplug the refrigerator by pulling on the power cord. Always grip the plug firmly, and pull straight out from the receptacle to prevent damaging the power cord.
- Unplug the refrigerator before cleaning and before replacing a light bulb to avoid electrical shock.
- Performance may be affected if the voltage varies by 10% or more. Operating the refrigerator with insufficient power can damage the compressor. Such damage is not covered under the warranty.
- Do not plug the unit into an electrical outlet controlled by a wall switch or pull cord to prevent the refrigerator from being turned off accidentally.

Grounding type wall receptacle

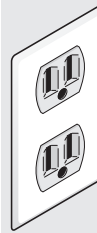

Do not, under any circumstances, cut, remove, or bypass the grounding prong.

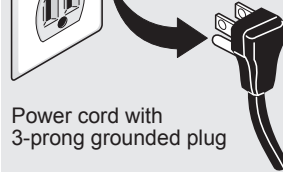

Power cord with 3-prong grounded plug



WARNING

When positioning the appliance, ensure the supply cord is not trapped or damaged.



WARNING

Do not locate multiple portable socket-outlets or portable power supplies at the rear of the appliance.

6

FEATURES

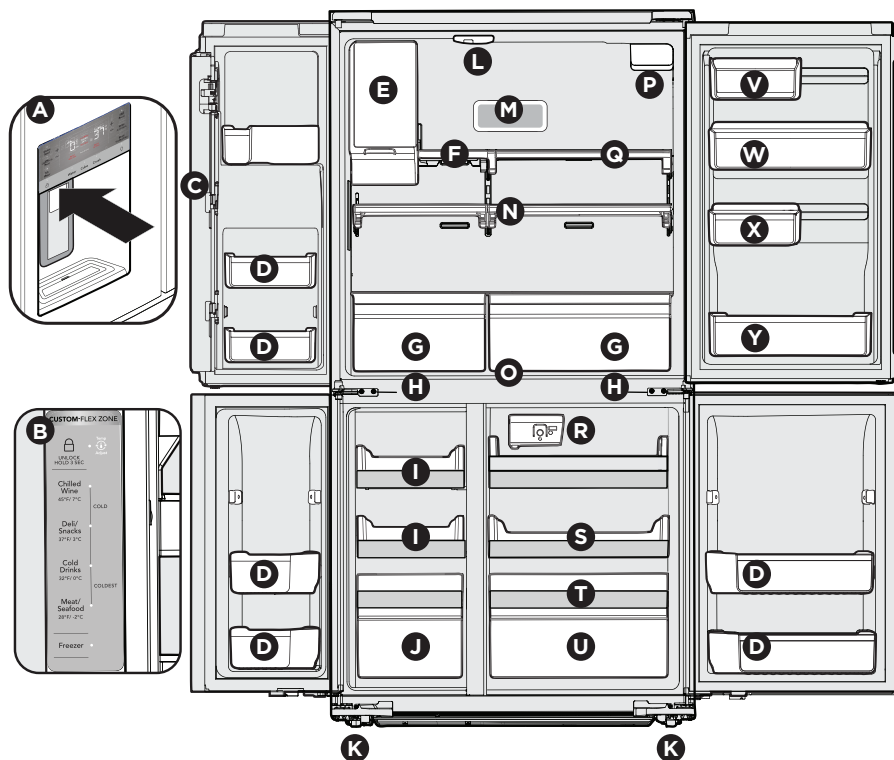

A	Ice and Water Dispenser**
B	Custom-Flex Zone Controls
C	Flipper Mullion
D	Door Bin
E	Fresh Food Ice Maker
F	Flip Shelf
G	Auto CrispSeal™ Drawers
H	Adjustable Hinges
I	Reversible Custom-Flex Zone Slide Shelf with Wine Rack Feature**

J	Custom-Flex™ Zone Drawer**
K	Anti-tip Leg
L	Flipper Mullion Guide
M	PureAir Ultra II® Air Filter
N	Full Width Shelf
O	SnackZone™ Storage Compartments (Recessed below Crispers)
P	PureSource Ultra® II Water Filter

Q	Slide-Under Shelf
R	Freezer Ice Maker*
S	Freezer Slide Shelf with Ice Container
T	Freezer Slide Shelf
U	Freezer Drawer
V	Dairy Compartment
W	Full Width Adjustable Door Bin
X	Fast Adapt Door Bin
Y	Fixed Door Bin

*Optional Accessory Shown

**Switches between Refrigerator and Freezer



IMPORTANT

Accessories are available for your appliance and may be purchased at Frigidaire.com or by calling 1-800-374-4432 (Frigidaire.ca or 1-800-265-8352 in Canada) or from an authorized seller.

Tools Necessary:

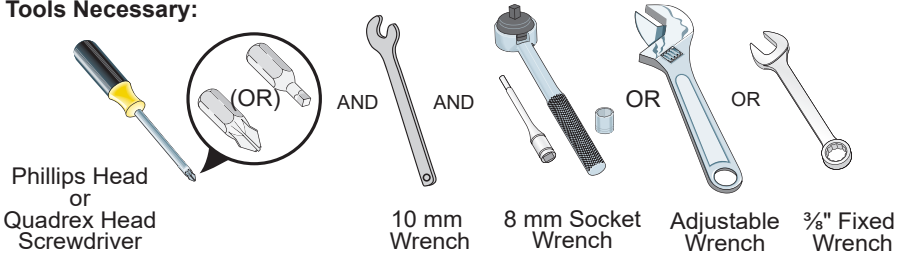

This Use & Care Manual provides general installation and operating instructions for this model. We recommend using a service or kitchen contracting professional to install the refrigerator. Use the refrigerator only as instructed in this Use & Care Manual. **Before starting the refrigerator, follow these important first steps.**

Location



WARNING

This appliance is intended to be used in household and similar applications such as:

- a kitchen/kitchenette
- a pantry room
- a basement
- an enclosed garage
- other interior residential-type environments

- Choose a place near a grounded, non-GFCI, electrical outlet. **Do Not** use an extension cord or an adapter plug.
- If possible, place the refrigerator out of direct sunlight and away from the range, dishwasher, or other heat sources.
- You must install the refrigerator on a floor level and strong enough to support a fully loaded refrigerator.
- Consider water supply availability for models equipped with an automatic ice maker.



CAUTION

Do Not install the refrigerator where the temperature will drop below 55°F (13°C) or rise above 110°F (43°C). The compressor will not be able to maintain proper temperatures inside the refrigerator.



WARNING

Installation

Allow the following clearances for ease of installation, proper air circulation, and plumbing and electrical connections:

Sides & Top	$\frac{3}{8}$ " (9.5 mm)
Back	1" (25.4 mm)



NOTE

If the refrigerator is placed with the door hinge side against a wall, allow additional space so the door can be opened wider.

8

INSTALLATION

Door opening

Position the refrigerator to allow easy access to a counter when removing food. For the best use of refrigerator drawers and freezer baskets, position the refrigerator where you can fully open both.

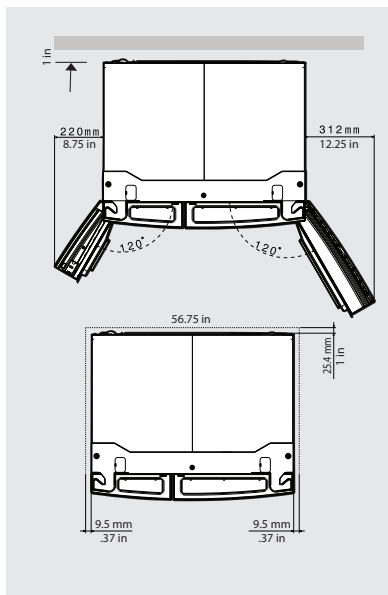

Cabinet Leveling & Refrigerator Door Alignment (if necessary)

Guidelines for final positioning of refrigerator:

- Firmly rest all 4 corners of the cabinet on the floor.
- Slightly elevate the front to ensure the doors close and seal properly.
- Align and level the doors with each other.

You can meet most of these conditions by raising or lowering the adjustable anti-tip legs.

To level the cabinet using the anti-tip legs:

1. Slightly open freezer compartment.
2. Lower anti-tip legs until they are both touching the floor. Use a pair of pliers to adjust.

To raise unit: turn leg clockwise.

To lower unit: turn leg counterclockwise.

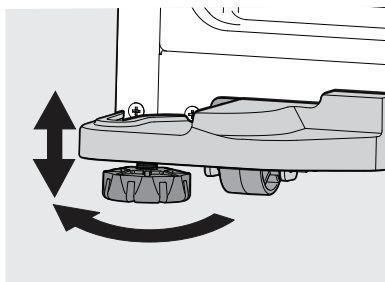

3. Ensure both doors are bind-free with their seals touching the cabinet on all 4 sides and the cabinet is stable.

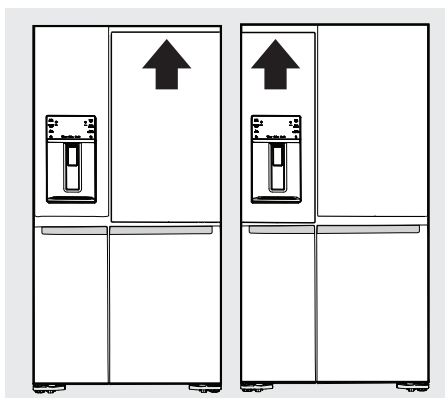

To make final door height adjustments:

1. Open the lower doors to make the middle hinge visible.
2. Insert the 10 mm wrench (included) into the shaft of the middle hinge.

To lower door: turn the adjustment screw clockwise.

To raise door: turn the adjustment screw counterclockwise.



NOTE

After adjusting the screw, you might need to swing the door to check for proper alignment.

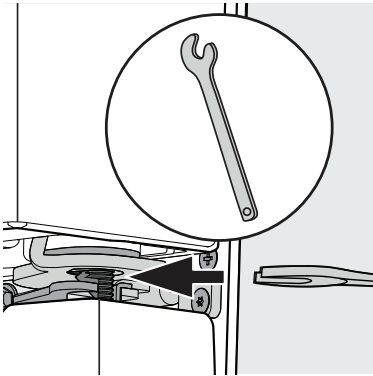

Bottom Doors Alignment

In a few cases the doors might not align vertically. To correct this condition a snap ring shim is supplied with the door alignment kit (in the literature pack). To assemble it, lift the lower door slightly to access the door hinge pin and insert the snap ring as illustrated.

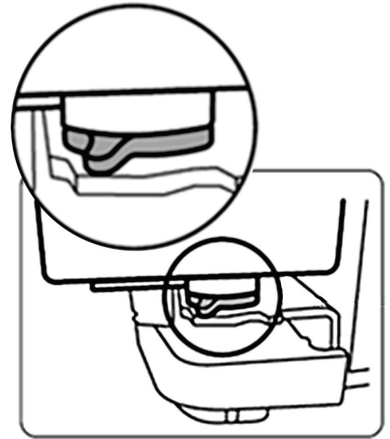
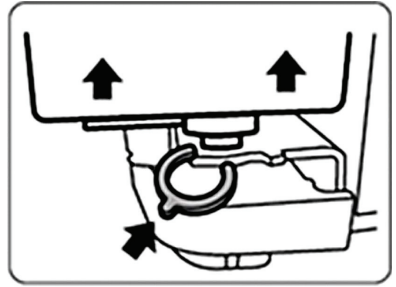
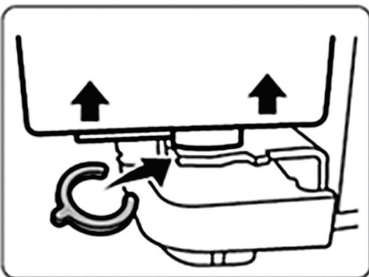
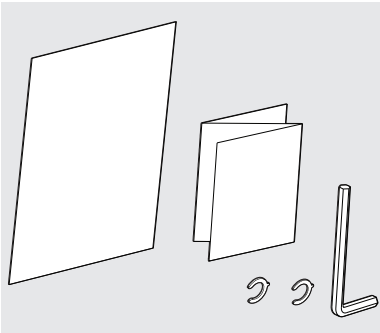

Flipper Mullion

Adjust the flipper mullion for proper connection with the mullion guide by ensuring the flipper mullion is folded and perpendicular to the fresh food door. If the mullion guide is not in the correct position, it could prevent the door from closing completely.

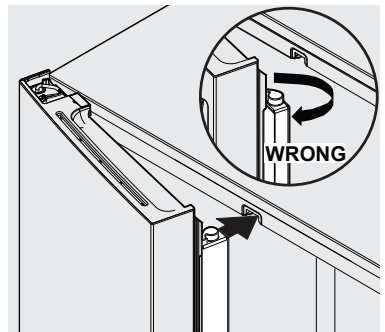

10 DOOR REMOVAL

Getting through narrow spaces

If the refrigerator will not fit through an entrance area, you can remove the doors. Check first by measuring the entrance.

To prepare for removing the doors:

1. Make sure you unplug the electrical power cord from the wall outlet.
2. Remove any food from the door shelves and close the doors.

To remove the refrigerator doors:

1. Open the doors to 90°.
2. Remove all 4 Phillips™ screws from top hinge cover and lift up.

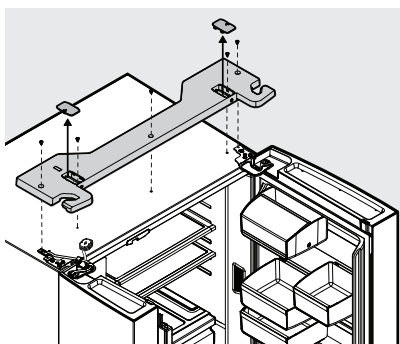

3. Trace lightly around the door's top hinges with a pencil. This makes reinstallation easier.
4. Disconnect electrical harnesses running from door to hinge cover on both doors.

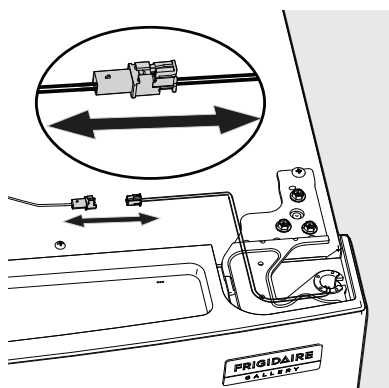

5. Unscrew the plastic clamps that hold the cables and tubes and then gently pull up on the water line to remove them from door.

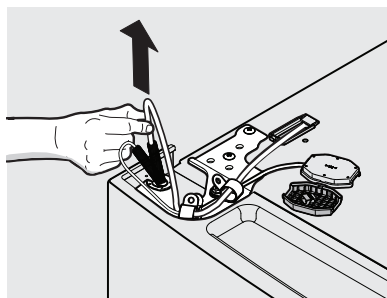

NOTE

Use care while pulling the water tube from the door to be sure the tube does not kink. To prevent damage to the water line, be sure to install the water line in a protective spring after reinstalling the doors.

NOTE

You will pull approximately 4 ft of water tube from the refrigerator door.

CAUTION

Be sure to set the doors aside in a secure position where they cannot fall and cause personal injury, or damage to the doors.

1. Remove three 8 mm bolts from both top hinges. Lift the doors up off the lower hinges and carefully set aside.

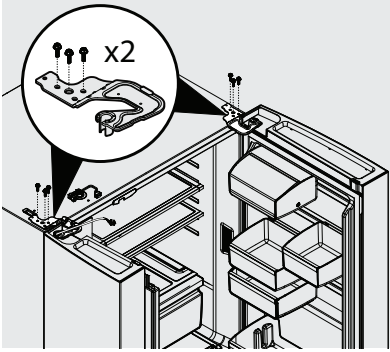

2. To reinstall the doors, reverse the procedure.



IMPORTANT

Make sure the water line tubing goes through the hole at the top of the dispenser pocket. A metal wrap on the tubing prevents damage from the hinge rubbing against it. Fix this back around the tube in the proper location upon reinstallation (just as long as the tube is protected from the hinge).



NOTE

When reinserting the water tube and replacing the top hinge cover, use care to be sure the tube does not kink.

Once both doors are in place, ensure they are aligned with each other and level (Reference **INSTALLATION** for more details), and replace the top hinge cover.

To remove bottom doors

1. Fully open the bottom doors in order to remove the bottom hinge cover.
2. Remove the screw and the bottom hinge cover.

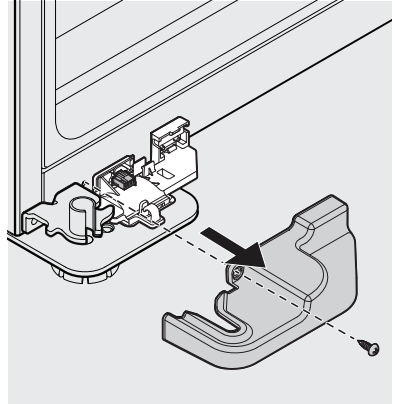

3. Disconnect the switch connector and detach the wires from the guide.

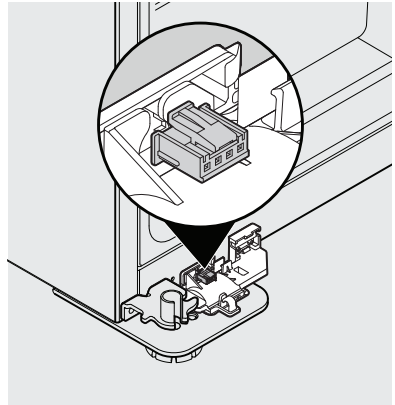

12 DOOR REMOVAL

4. Make sure you removed the top doors.
5. With the bottom doors closed, remove the center hinge unscrewing the 3 screws fixing them to the cabinet.
7. Repeat this procedure for both bottom doors.



NOTE

To gain access to center hinge, unscrew the 3 hinge screws and remove the hinge.

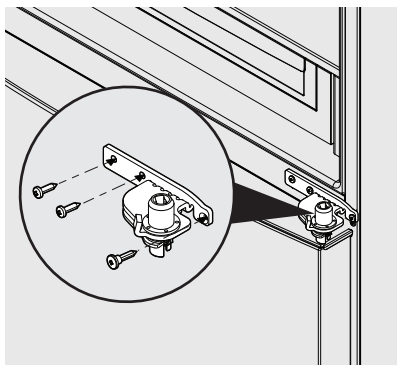

Center Hinge Removal

6. Carefully remove the door by opening it and pushing it upward.
8. To reinstall the doors, reverse the procedure.

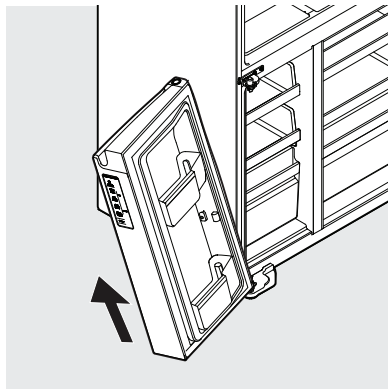



WARNING

To avoid electric shock, which can cause death or severe personal injury, disconnect the refrigerator from electrical power before connecting a water supply line to the refrigerator.



CAUTION

To Avoid Property Damage:

- We recommend using Copper or Stainless Steel braided tubing for the water supply line. We do not recommend using water supply tubing made of 1/4" plastic. Plastic tubing greatly increases the potential for water leaks, and the manufacturer will not be responsible for any damage if you use plastic tubing for the supply line.
- DO NOT install water supply tubing in areas where temperatures fall below freezing.
- Chemicals from a malfunctioning water softener can damage the ice maker. If a water softening system is present, maintain the softener and ensure it is working properly.



IMPORTANT

Ensure the water supply line connections comply with all local plumbing codes.

To install the water supply line, you will need the following:

- Basic Tools: adjustable wrench, flat-blade screwdriver, and Phillips™ screwdriver
- Access to a household cold water line with water pressure between 30 and 100 psi.
- A water supply line made of 1/4" (6.4 mm) OD, copper or braided stainless steel tubing. To determine the length of tubing needed, measure the distance from the inlet water tube at the back of the refrigerator to the cold water pipe. Then add approximately 7 ft (2.1 m.), so you

can move the refrigerator for cleaning.

- A shutoff valve to connect the water supply line to the household water system. DO NOT use a self-piercing type shutoff valve.
- Do not reuse compression fitting or use thread seal tape.
- A compression nut and ferrule (sleeve) for connecting a copper water supply line to the ice maker inlet valve.



NOTE

Check with local building authority for recommendations on water lines and associated materials prior to installing refrigerator. Depending on local/state building codes, we recommend **Smart Choice®** water line kit 5304437642 with a 6 ft. (1.8 meters) braided Stainless Steel Water Line for homes with existing valves. Please refer to Frigidaire.com for more information.



NOTE

Expect the first ice harvest within first 24 hours of unit operation. To prevent any issues concerning ice production, please ensure that all water lines are primed. See **Priming the water supply system** in the **ICE MAKER** section.



IMPORTANT

The refrigerator's water supply system includes several tubing lines, a water filter, and a water valve. To ensure the water dispenser works properly, you must completely fill this system with water when you first connect the refrigerator to the household water supply line.



NOTE

The water dispenser has a built-in device that shuts off the water flow after 2 minutes of continuous use. To reset this shutoff device, simply release the dispenser paddle.

14

WATER SUPPLY CONNECTION

Connection to Household Water Supply with 1/4" compression fitting

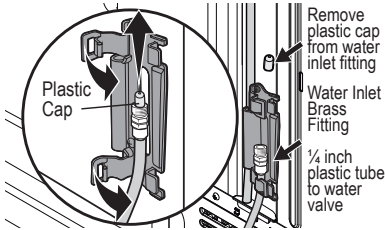
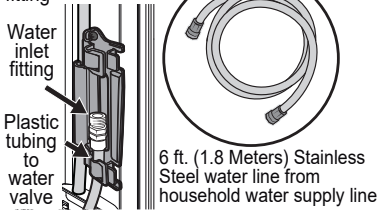

To Connect the Water Tube to Household Water Supply

1. Disconnect the refrigerator from the electrical power source.
2. Place the end of the water supply line into a sink or bucket. Turn ON the water supply and flush the supply line until the water is clear. Turn OFF the water supply at the shutoff valve.

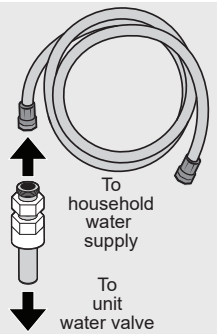

3. Open the locking clips and grab the water line coming from the refrigerator. Remove the plastic cap from the water inlet fitting and discard the cap.

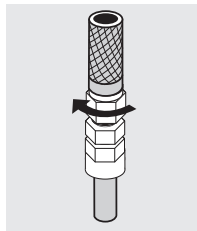

4. If you use (recommended) stainless steel braided tubing - the nut and ferrule are already assembled on the tubing. Slide the compression nut onto the water inlet fitting and finger tighten.
5. Using two 1/2" wrenches (one to hold the household water line nut and the other to hold the water inlet fitting nut), tighten a half turn with wrench. DO NOT overtighten.

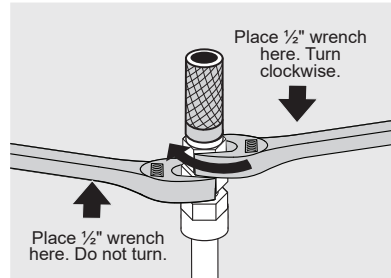

6. Replace the connected tubes into the clips and lock the clips back in place to keep the tubing in the right position.
7. Turn ON the water supply at the shutoff valve and tighten any connections that leak.
8. Reconnect the refrigerator to an electrical power source.
9. Turn on the ice maker.
10. Purge air from the ice and water dispenser system by operating the water dispenser for 3-4 minutes. This requires dispensing several glasses of water.

Sleep Mode Display

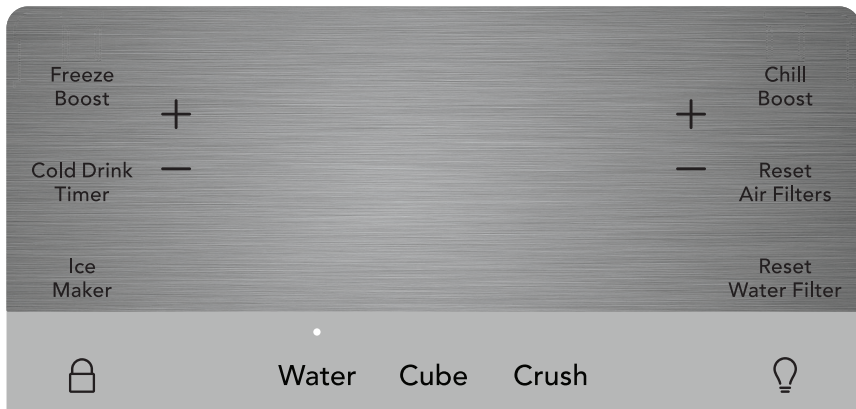

Sleep Mode

As a default, the display goes to sleep after a short time. If you press any icon, the display awakens. After a short time, it goes back to sleep. When in sleep mode, wake up the display to confirm the ice maker is On/Off. You can turn sleep mode off to have the display on full time (awake mode). When sleep mode is Off, the display is always illuminated. To turn sleep mode On/Off, simultaneously press and hold **Crush** and  for 5 seconds. An audible tone confirms the selection is set.

NOTE

When the refrigerator temperature is adjusting and the adjusting temperature icon is on, the sleep mode is disabled until the unit reaches the desired temperature.

Awake Mode Display

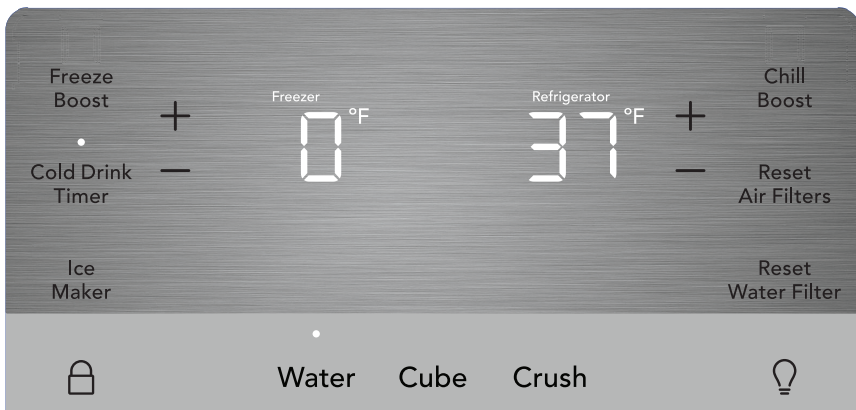

Awake Mode

To change from sleep mode (on) to awake mode (off), simultaneously press and hold **Crush** and  for 5 seconds. The display shows the current temperature/ice maker status. An audible tone confirms the selection is set.

Appliance Control Display Settings

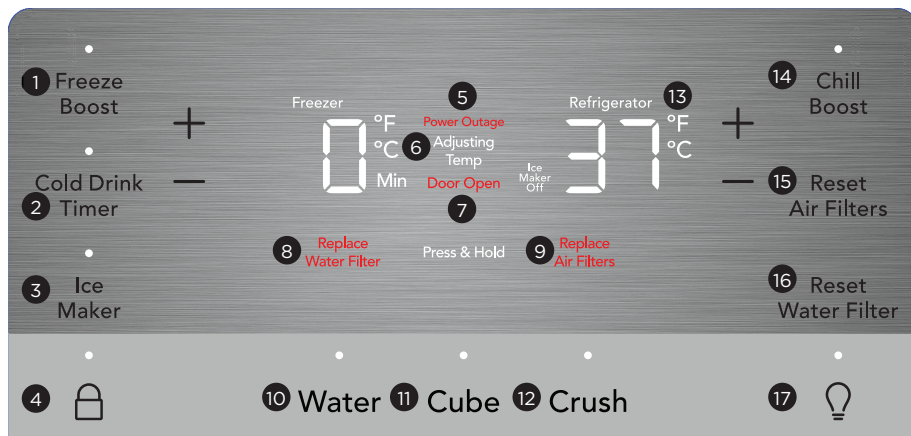

1 Freeze Boost (on/off)
Prior to grocery shopping, activate **Freeze Boost** to lower the temperature and freeze food faster. **Freeze Boost** remains active for up to 12 hours before automatically deactivating or manually exiting by pressing **Freeze Boost** to turn the function off. This will reset the freezer to the previous temperature setting.

2 Cold Drink Timer
Quickly chills a drink inside the freezer compartment. To enable, touch the Cold Drink Timer key. A time value will appear on the freezer temp display (in minutes) and can be changed using the +/- buttons. A tone will sound when the time has been input. Range is from 20-45 minutes in 5 minute intervals. Drinks will freeze if temperature setting is too low or timer setting is too long.

WARNING

When using the cold drink timer, be sure to remove drinks from the freezer compartment when the alarm sounds. Carbonated drinks may explode if left in freezer for too long.

3 Ice Maker On/Off
Press and hold for 3 seconds to turn ice maker on/off. When indicator is lit, ice maker is on. When ice maker is OFF, ice maker OFF indicator is lit. When ice maker is in the OFF state, it will stop making ice. When sleep mode is enabled, wake the display to confirm ice maker is on/off (see **Sleep Mode**). While off, ice dispensing can continue as long as there is ice in the bucket. When ice maker is off and ice is dispensing, indicator above ice maker button and ice maker OFF will both blink.

4 The lock button can be used to lock the display preventing it from being used in certain situations. Press and hold for 3 seconds to enable/disable. While in the locked state, no changes can be made to settings on the display. Dispensing ice and water will be disabled. The indicator will flash and an audible warning tone is played.

5 Power Outage
In the event of a power failure, the power outage alert will be illuminated once power has been restored and a tone will sound. Press any button to silence the tone.

- 6 Adjusting Temp** illuminates when you press either **+** or **-** to change temperature setting on the appliance display and will remain illuminated until the refrigerator and freezer reach the desired temperatures inside.

Freezer temp

Control temperatures range from -6°F / -21°C to 6°F / -15°C.

Refrigerator temp

Control temperatures range from 34°F / 1°C to 44°F / 7°C. This unit is designed to operate at 37°F Refrigerator/0°F Freezer. Temperatures should stabilize within 24 hours of installation.



NOTE

When in Sleep mode, the display will not illuminate. Touch any key to wake the display.

- 7 Door Open** illuminates whenever you open the doors. If you leave a door open for 5 minutes or more, an alarm sounds and the display illuminates until you shut the doors. Press any button to mute the alarm temporarily. Check to make sure no food is blocking the doorway.
- 8 Replace Water Filter** illuminates every 6 months or when you need to replace the filter. Replace the filter and then press and hold **Reset Water Filter** for 3 seconds to deactivate the warning on the display. See **FILTER REPLACEMENT** for more information.
- 9 Replace Air Filters** illuminates every 6 months or when you need to replace the filter. Replace the filter and then press and hold **Reset Air Filters** for 3 seconds to deactivate the warning on the display. See **FILTER REPLACEMENT** for more information.

- 10** Press **Water** to select water. An indicator light illuminates above the active feature. Press the paddle to dispense water.

- 11** Press **Cube** to select cubed ice. An indicator light illuminates above the active feature. Press the paddle to dispense cubed ice.



- 12** Press **Crush** to select crushed ice. An indicator light illuminates above the active feature. Press the paddle to dispense crushed ice.

- 13 °F/°C**
To toggle between Fahrenheit (°F) and Celsius (°C), simultaneously press and hold **+** and **-** for 5 seconds on the refrigerator side of the appliance display control.

- 14 Chill Boost**
Prior to grocery shopping, activate **Chill Boost** to lower the temperature and cool food faster. **Chill Boost** remains active for up to 6 hours before automatically deactivating or manually exiting by pressing **Chill Boost** to turn the function off. This resets the freezer to the previous temperature setting.

- 15 Reset Air Filters**
After replacing the filter, press and hold for 3 seconds to reset.

- 16 Reset Water Filter**
After replacing the filter, press and hold for 3 seconds to reset.

- 17**  Toggles dispenser light On and Off. Press and hold  for 5 seconds to turn on the ambient lighting, located under the fresh food doors. Press and hold again for 2 seconds to turn this feature off.

18

CONTROLS AND SETTINGS

Setting Temperatures

NOTE

The recommended settings for a product installed in a kitchen is 37°F for the fresh food compartment and 0°F for the freezer.

IMPORTANT

If food is freezing in the fresh food compartment, increase the temperature setting by 1 or 2 degrees. Wait 24 hours for temperature to stabilize.

IMPORTANT

Food placed within 1 inch in front of the air ports may cause food to freeze. Ensure air ports are not blocked.

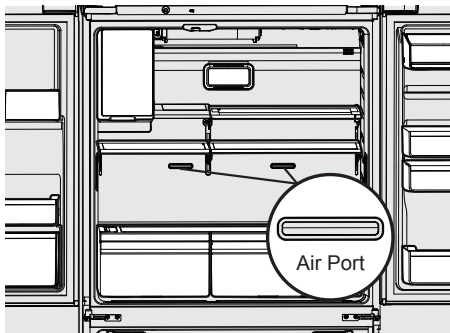

NOTE

The unit should stabilize temperatures within 24 hours of installation.

Alarms

Power Outage

In the event of a power failure, the power outage alert illuminates once power has been restored and a tone sounds. Press any button to silence the tone.

Door Open

If you have left a door open for 5 minutes or more, an alarm sounds and the door open indicator illuminates on the display. You can turn off the alarm by closing the door or pressing any key. The appliance control display returns to normal operations after you close the door.

High Temperature

In the event of a high temperature condition, an alarm sounds. The appliance control display reads **HI** on whichever compartment the alert is detected in and an alarm sounds over 10 seconds until you acknowledge the alert. You can turn off the alarm by closing the door or pressing any key.

Flapper (Dispenser Models Only)

If the flapper (or ice chute door) is held open by a jammed ice cube when you select **Cube** or **Crush**, an alarm sounds and the current selection blinks on the dispenser control. The alarm resets when you remove the ice cube.

**NOTE**

You must manually turn off the optional freezer ice maker to comply with sabbath mode.

Sabbath Mode

The Sabbath Mode is a feature that disables portions of the refrigerator and its controls in accordance with observance of the weekly Sabbath and religious holidays within the Orthodox Jewish community.

Turn Sabbath Mode ON and OFF by simultaneously pressing and holding both **—** (freezer side) and **+** (refrigerator side) for 5 seconds. Other than the High Temp alarm, no audible sounds occur until you exit the Sabbath Mode. The appliance control display shows **Sb** while in Sabbath mode.

In the Sabbath Mode, the High Temp alarm is active for health reasons. For example, if you leave the door ajar it activates the High Temp alarm. The refrigerator functions normally once you close the door, without any violation of the Sabbath/holidays. The High Temp alarm sounds when the cabinet temperature is outside the safe zone for 20 minutes. The alarm silences itself after 10 minutes while **High Temp** stays lit until you exit the Sabbath Mode.



For further assistance, guidelines for proper usage and a complete list of models with the Sabbath feature, please visit the web at star-k.org.

**NOTE**

While in Sabbath Mode, neither the lights, the dispenser, nor the display will work until you deactivate Sabbath Mode.

The refrigerator stays in Sabbath Mode after power failure recovery. You must deactivate it with the buttons on the appliance control display.

**NOTE**

Although you have initiated the Sabbath Mode, the ice maker completes the cycle it has already started. The ice cube compartment remains cold and you can make new ice cubes with standard trays.

20 ICE MAKER

Using the Ice Maker After Installation

Before making ice for the first time, be sure to prime the water supply system. Air in new plumbing lines can result in 2 or 3 empty ice maker cycles. Furthermore, if you do not flush the system, the first ice cubes may be discolored or have an odd flavor.

Priming the Water Supply System



CAUTION

We recommend a water supply pressure between 30 psi and 100 psi. The system may malfunction with excessive pressure.

1. Begin filling the system by pressing and holding a drinking glass against the dispenser.
2. Keep the glass in this position until water comes out of the dispenser. It may take about 1 1/2 minutes.
3. Continue dispensing water for 3-4 minutes (or after you have dispensed 1 1/2 gallons) to flush the system and plumbing connection of any impurities, stopping to empty the glass as necessary.

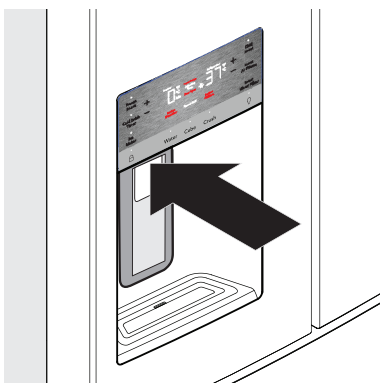

Dispenser



NOTE

The water dispenser has a built-in device that shuts off the water flow after 2 minutes of continuous use. To reset this shutoff device, simply release the dispenser paddle.



NOTE

After the initial 26 ounces (750 ml), the water remains room temperature until the tank refills and has enough time to chill the next 26 ounces (750 ml) of water. It may take up to 8 hours to chill.

Ice Maker Operation and Care

After you have properly installed the refrigerator and it has cooled for several hours, the ice maker produces ice within 24 hours. The ice maker fills the ice bin from the rear. Dispense some ice to force the ice forward in the bin. This allows the bin to fill completely.

Ice Maker and Storage Bin Capacity

The ice maker should produce 3.2 to 3.7 lbs of ice per 24 hours, depending on the usage conditions. The fresh food ice bin holds about 4 lbs of ice.

Turning the Fresh Food Ice Maker On and Off



IMPORTANT

The ice maker is turned on at the factory so it can work as soon as you install the refrigerator. If you cannot connect a water supply, set the ice maker's On/Off feature to **Off**; otherwise, the ice maker's fill valve may make a loud chattering noise when it attempts to operate without water.

Ice production is controlled by the ice maker's On/Off feature on the appliance control display. Pressing the On/Off feature turns the ice maker on and off.

**NOTE**

The ice maker also has a built-in plastic signal arm that automatically stops ice production when the ice bin is full. Do not use this signal arm to manually stop the ice maker.

**IMPORTANT**

Turning off the ice maker simply disables ice making. You can still dispense existing ice and water.

**NOTE**

We recommend you turn the ice maker off if you will not use the refrigerator for an extended period of time.

**IMPORTANT**

Occasionally, you may notice unusually small ice cubes in the bucket or in dispensed ice. This could occur in normal operation of the ice maker. If this happens frequently, it may indicate low water pressure or the water filter needs to be replaced. As the water filter nears the end of its useful life and becomes clogged with particles, less water is delivered to the ice maker during each cycle. Remember, if it's been 6 months or longer or you have dispensed more than 200 gallons (757 liters) since last changing the water filter, replace it with a new one. You may have to change the filter more frequently if you have poor quality household water.

**CAUTION**

Properly maintain the water supply to the refrigerator if it is softened. Chemicals from a water softener can damage the ice maker.

Ice maker/dispenser tips

If refrigerator is not connected to a water supply or the water supply is turned off, turn off the ice maker as described in the previous section.

The following sounds are normal when the ice maker is operating:

- Motor running
 - Ice dropping into ice bin
 - Water valve opening or closing
 - Running water
- If you need a large quantity of ice at one time, it is best to get cubes directly from the ice bin.
 - Ice cubes stored too long may develop an odd flavor. Empty the ice bin as explained below.
 - When dispensing cubed ice, it is normal to have a small quantity of little pieces along with the whole cubes.
 - To avoid splashing, dispense ice into the container before adding liquids.
 - It is normal for ice to fill to the top of the ice bin.

Cleaning the Ice Bin

Regularly clean the ice maker and ice bin, especially prior to vacation or moving.

1. Turn off the ice maker.
2. Remove the ice bin by lifting it upward and pulling it straight out.
3. Empty and carefully clean the ice bin with mild detergent. Do not use harsh or abrasive cleaners. Do not place it in the dishwasher. Rinse with clear water.
4. Allow the ice bin to dry completely before replacing it into the compartment.
5. Replace the ice bin. Turn the ice maker on.

22 ICE MAKER

Remove and empty the ice bin if:

- An extended power failure (1 hour or longer) causes ice cubes in the ice bin to melt and refreeze together after power is restored, jamming the dispenser mechanism.
- You use the ice dispenser. Ice cubes will freeze together in the bin, jamming the dispenser mechanism.

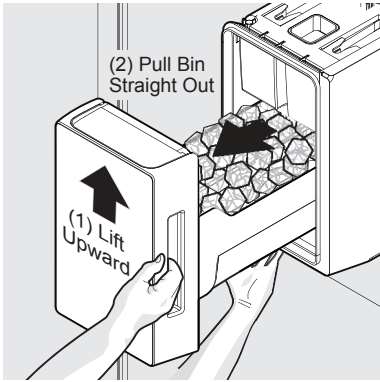

Removing Ice Bin

Remove the ice bin by (1) lifting upward and (2) pulling straight out. Then shake to loosen the cubes or clean as explained above.



CAUTION

NEVER use an ice pick or similar sharp instrument to break up the ice. This could damage the ice bin and dispenser mechanism.

To loosen stuck ice, use warm water. Before replacing the ice bin, make sure it is completely dry.



IMPORTANT

When removing or replacing the ice bin, avoid rotating the auger in the ice bin. If you accidentally rotate the auger, realign the auger by turning it in 45° turns (see below) until the ice bin fits into place with the drive mechanism. If you do not properly align the auger when replacing the ice bin, the refrigerator will not dispense ice. The fresh food door also may not close properly causing warm air to leak into the fresh food compartment.

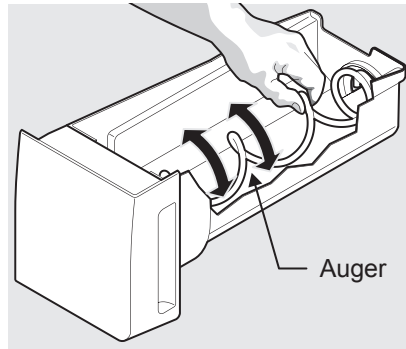

Adjusting Ice Bin Auger

Freezer Ice Maker (optional accessory)

Ordering Optional Freezer Ice Maker

Order the optional freezer ice maker at Frigidaire.com, by calling 1-800-374-4432 or through the dealer from which you purchased the refrigerator.

Ice Maker Operation and Care

After you have properly installed the refrigerator, the ice maker can produce ice within 24 hours. When using the ice maker for the first time, and in order for it to work properly, you need to clear air from the water tubing and the filter. Furthermore, if you do not flush the system, the first ice cubes may be discolored or have an odd flavor. Once the ice maker begins making ice, allow the bin to fill completely, and then discard the first FULL bin of ice.

Ice Maker and Storage Bin Capacity

This ice maker should produce between 2 and 2.5 lbs of ice per 24 hours depending on usage conditions. The ice bin will hold about 6 lbs of ice.

NOTE

The ice maker will only produce the advertised production rate if the product is set at 0°F.

Turning the Ice Maker On and Off

Press or slide the power button to turn the ice maker on/off. The button and LED illuminate when active. (A - power button, B - test button)

varies by model

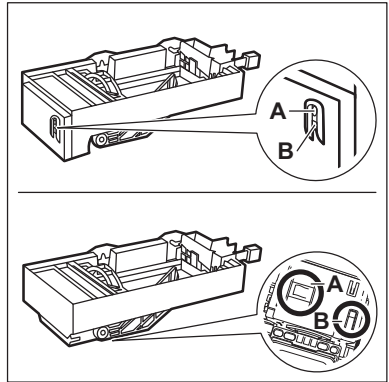

NOTE

The freezer ice maker fills in the center of the ice bin. Occasionally move the ice to the borders to allow the bin to fill completely.

Ice Maker Tips

- The following sounds are normal when the ice maker is operating:
 - Motor running
 - Ice dropping into ice bin
 - Water valve opening or closing
 - Running water
- Ice cubes stored too long may develop an odd flavor. Empty the ice bin. (See **To remove freezer ice container:** in **STORAGE FEATURES**).

CAUTION

Properly maintain the water supply to the refrigerator if it is softened. Chemicals from a water softener can damage the ice maker.

24 STORAGE FEATURES



CAUTION

To avoid personal injury or property damage, handle tempered glass shelves carefully. Shelves may break suddenly if nicked, scratched, or exposed to sudden temperature change. Allow the glass shelves to stabilize to room temperature before cleaning. Do not wash in the dishwasher.

You can easily adjust shelf positions in the fresh food compartments as needed. The shelves have mounting brackets that attach to slotted supports at the rear of each compartment.

Change the Position of a Shelf

1. Remove all food from the shelf.
2. Lift the front edge up and pull the shelf out.
3. Replace by inserting the mounting bracket hooks into the desired support slots.
4. Lower the shelf and lock it into position.

To adjust the flip shelf:

1. Remove food from the shelf.
2. Lift the right side edge of the shelf upward and push to the left toward the ice maker.

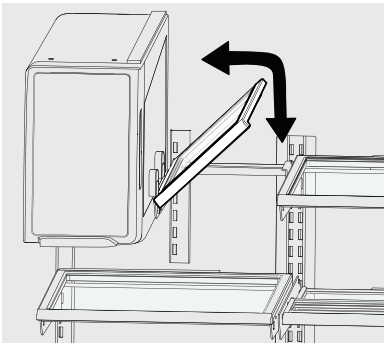

Flip Shelf

To adjust the slide-under shelf:

Push the front half shelf backward toward the rear of the cabinet until the rear half shelf drops down. Then gently continue pushing the front half shelf back and under the rear half shelf.

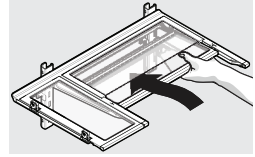

Slide-Under Shelf

Drawers

The refrigerator includes a variety of storage drawers.

Auto CrispSeal Drawer

Crispers are designed for storing fruits, vegetables, and other fresh produce. Crispers have an auto humidity control at the rear of each crisper under the humidity control cover.

To remove the auto humidity control membrane for cleaning:

1. Reach to back of the humidity control cover.
2. Place fingers between the humidity control and the back wall, pulling up on the cover.
3. Pull the cover toward the front of the cabinet and remove.
4. Remove the humidity membrane from the housing by lifting it up and sliding it over.
5. Clean the humidity membrane with hot soapy water. Thoroughly dry it before replacing.
6. Replace the membrane in the housing and unit by reversing the steps above.

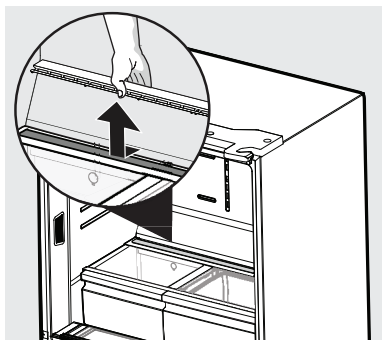

Removing Auto Humidity Control Membrane



NOTE

We do not recommend replacing the auto-humidity membrane unless it becomes damaged or ruined. If the membrane becomes soiled, you can wash it with soap and water. Ensure the membrane is dry before replacing it in the unit.

SnackZone - Recessed Snack Drawers

These drawers are ideal for storing deli meats and cheeses.

To open: slide back the cover to allow access to the drawers.

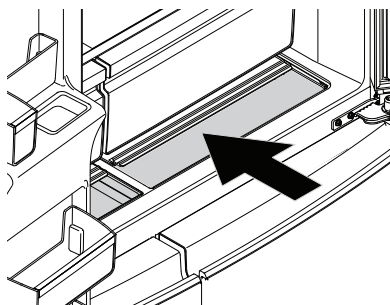

Opening SnackZone Recessed Snack Drawers

To remove the Auto CrispSeal drawer for cleaning:

1. Pull the drawer out until it stops.
2. Lift the front slightly and remove the drawer.

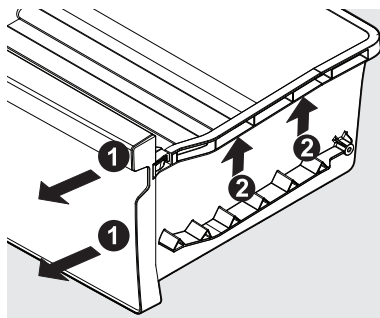

Removing Auto CrispSeal Drawer

26 STORAGE FEATURES

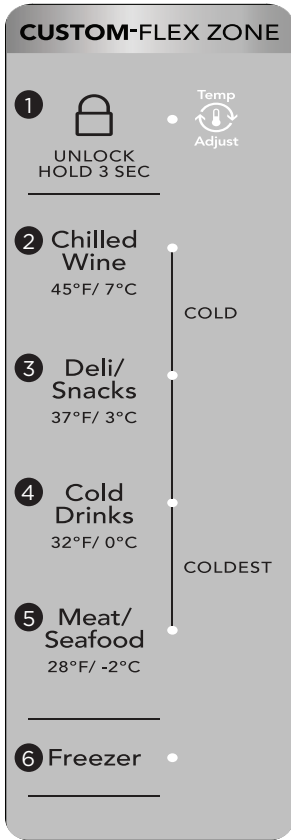

Custom-Flex Zone

You can adjust the Custom-Flex Temp Zone from -6° F to 45° F, giving you versatility and control of your appliance.



CAUTION

Do not store glass bottles in the Custom-Flex Zone when the temperature setting is in **Freezer**, **Meat/Seafood**, or **Cold Drink** modes. The glass may break and shatter, causing physical harm and injury.



IMPORTANT

Do not use the Custom-Flex Zone to store fresh produce as these items may freeze and cause damage to the fruits and leafy vegetables stored in the drawer.



NOTE

Temp Adjust stays lit until reaching the new set temp.

Using Your Custom-Flex Zone Controls

- 1 The Custom-Flex Zone automatically defaults to a locked state to prevent any unwanted use. To change the Custom-Flex Zone's settings, you must first unlock it. To unlock, press and hold **UNLOCK** for 3 seconds. It automatically locks after 10 seconds without any interaction.

Refrigerator:

- 2 Choosing **Chilled Wine** sets the zone temperature to 45°F (7°C). A tone sounds to confirm choice.
- 3 Choosing **Deli/Snacks** sets the zone temperature to 37°F (3°C). A tone sounds to confirm choice.
- 4 Choosing **Cold Drinks** sets the zone temperature to 32°F (0°C). A tone sounds to confirm choice.
- 5 Choosing **Meat/Seafood** sets the drawer temperature to 28°F (-2°C). A tone sounds to confirm choice. Use this setting for short-term storage. Place any meat to be kept longer than 2 days in the freezer.

Freezer:

- 6 To change the Custom-Flex Zone temperature when in the freezer temp setting, use the appliance control display on the front door. Changing the temp on the display changes both the Custom-Flex Zone **AND** the freezer temp settings.

Custom-Flex Zone

To remove Custom Flex-Zone shelves and drawers:

1. Open doors completely to gain access to shelves/drawers.
2. Pull the shelf/drawer to the stopper. Lift the shelf/drawer up and pull it to remove it from the cabinet.
3. Reverse the steps to reinstall the shelf/drawer.

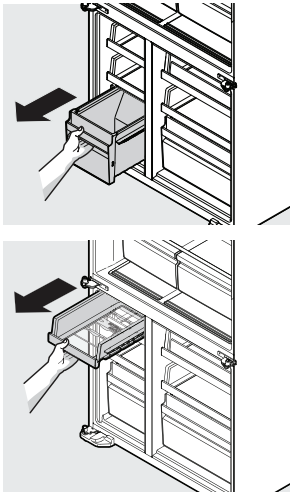

You can mount the middle drawers in the freezer and Flex-Zone in up to 3 height positions and can also invert them 90° allowing bottles to be stored in the Flex-Zone.

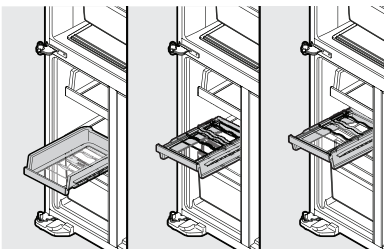

Shelves in 3 Height Positions and Inverted

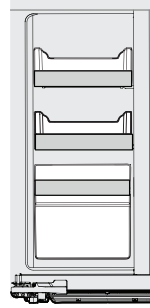

Possible Shelf Configuration Example

To remove the Wine Rack Mat:

1. Unhook the rack from the shelf.
2. Pivot as shown in the image and remove the silicone mat.

→ IMPORTANT

The Wine Rack Mat helps to keep the bottles from sliding off when opening the Custom-Flex Zone drawers.

→ IMPORTANT

You can remove and clean the Wine Rack Mat with tap water.

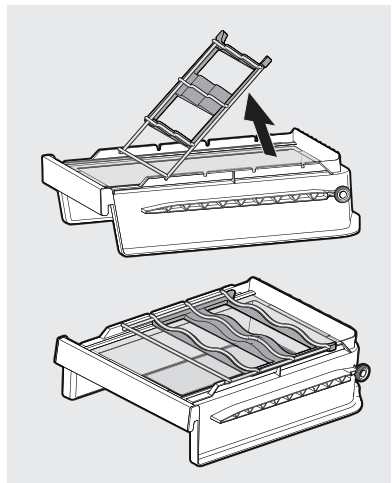

28 STORAGE FEATURES

Doors

Storage bins

The doors use a system of modular storage bins. You can remove all of these bins for easy cleaning. Adjust the bins as needed.

Use the door bins to store jars, bottles, cans, and large drink containers. You can also quickly select frequently used items.

Adjustable door bins

Move the adjustable door bins to suit individual needs.

To adjust the collapsible door bin:

1. Make sure the bin is securely seated on rail in the door.
2. Grab one side of the bin and place the other hand on the adjustable side.
3. Pull on the side of the bin until the bin is adjusted to the desired width.

To move the door bin side to side:

1. Tilt the bin up so the back of the bin is off the door but the hook is still engaged.
2. Slide the bin along the rail to the desired position.
3. Lower the bin back into place.

To move the door bin up or down:

1. Lift the bin up disengaging the hook.
2. Move the bin to the desired rail location.
3. Push the bin hook into the rail engaging the hook.

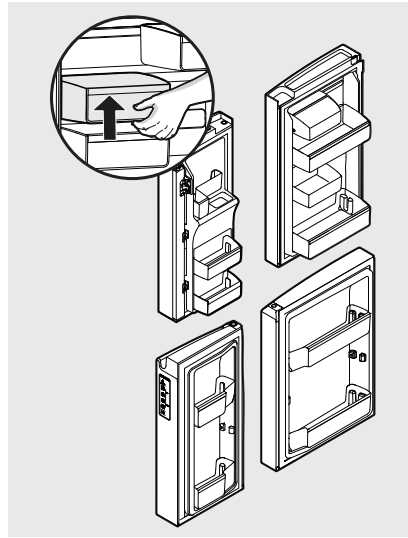

Adjustable Door Bins

To remove freezer ice container:

1. Open the doors completely to gain access to the drawers.
2. Pull the freezer drawer to its most forward position.
3. Lift up the front side of the ice container and pull it out of the drawer.
4. Allow the ice container to dry completely before replacing it in the freezer. Reverse the steps to reinstall the ice container.

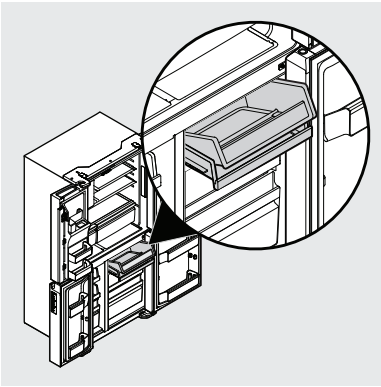

IMPORTANT

If you do not correctly assemble the ice container with the slider shelf, it will not close properly and may damage the freezer ice maker. Check to make sure door closes properly after removing the ice container. If you leave a door ajar, frosting or condensation may collect in the freezer.



IMPORTANT

Make sure all the wheels on the back of the shelves are aligned on their respective tracks for proper function. If the shelf is not aligned properly, the door will not operate properly.

Ideas for storing foods

Fresh food storage

- Keep the fresh food compartment between 34°F and 44°F with an optimum temperature of 37°F.
- Avoid overcrowding the refrigerator shelves, which reduces air circulation and causes uneven cooling.
- Avoid placing food in front of air ports. (See **CONTROLS AND SETTINGS**.)

Fruits and vegetables

- Store fruits and vegetables in crispers, where trapped moisture helps preserve food quality for longer time periods.
- Do not wash items until you are ready to use them. Remove excess water before placing them inside the unit.
- Wrap any items with strong odors or high moisture content.

Meat

- Wrap raw meat and poultry separately and securely to prevent leaks and contamination of other foods or surfaces.
- Use the Custom-Flex Temp Zone to store meat/poultry for short-term storage. Freeze any meat to be kept longer than 2 days.

Frozen food storage

- Keep the freezer compartment at 0°F or lower.
- A freezer operates most efficiently when it is at least $\frac{3}{4}$ full.

Packaging foods for freezing

- To minimize food dehydration and quality deterioration, use aluminum foil, freezer wrap, freezer bags, or airtight containers. Force as much air out of the packages as possible and seal them tightly. Trapped air can cause food to dry out, change color, and develop an off flavor (freezer burn).
- Wrap fresh meats and poultry with suitable freezer wrap prior to freezing.
- Do not refreeze meat that has completely thawed.

Loading the freezer

- Prior to grocery shopping, activate **Freeze Boost** so newly purchased

food designated for the freezer will be preserved as quickly as possible.

- Activating **Freeze Boost** also will help the freezer more efficiently maintain the selected temperature after placing new purchases with pre-existing frozen foods.
- Avoid adding too much warm food to the freezer at one time. This overloads the freezer, slows the rate of freezing, and can raise the temperature of frozen foods.
- Leave a space between packages, so cold air can circulate freely, allowing food to freeze as quickly as possible.

Ideas for saving energy

Installation

- Locate the refrigerator in the coolest part of the room, out of direct sunlight, and away from heating ducts or registers.
- Do not place the refrigerator next to heat-producing appliances such as a range, oven, or dishwasher. If this is not possible, a section of cabinetry or an added layer of insulation between the 2 appliances will help the refrigerator operate more efficiently.
- Level the refrigerator so the doors close tightly.

Temperature settings

- Refer to **CONTROLS AND SETTINGS** for procedures on temperature settings.

Food storage

- Avoid overcrowding the refrigerator or blocking cold air vents. Doing so causes the refrigerator to run longer and use more energy.
- Cover foods and wipe containers dry before placing them in the refrigerator. This cuts down on moisture build-up inside the unit.
- Organize the refrigerator to reduce door openings. Remove as many items as needed at one time and close the door as soon as possible.
- Do not place a hot container directly on a cold shelf. Remember, such an extreme temperature change may damage the glass.

Understanding the Sounds Coming from the Refrigerator

High-efficiency refrigerators may introduce unfamiliar sounds. These sounds normally indicate you are correctly operating the refrigerator. Some surfaces on floors, walls, and kitchen cabinets may make these sounds more noticeable.

The following is a list of major components in the refrigerator and the sounds they can cause:

- A Evaporators** Refrigerant through the evaporators may create a boiling or gurgling sound.
- B Evaporator fans** Sounds of air being forced through the refrigerator by the evaporator fans may be heard.
- C Defrost heaters** During defrost cycles, water dripping onto the defrost heaters may cause a hissing or sizzling sound. After defrosting, a popping sound may occur.
- D Automatic ice maker** When ice has been produced, sounds of ice cubes falling into the ice bin may be heard. Ice maker fan, water valve activation, and refrigerant gas fluid may create sounds from its operation.
- E Electronic control & automatic defrost control** These parts can produce a snapping or clicking sound when turning the cooling system on and off.
- F Condenser fan** Sounds of air being forced through the condenser may be heard.
- G Compressor** Modern, high-efficiency compressors run much faster than previous models. The compressor may have a noticeable hum or pulsating sound during operation.
- H Water valves** Make a buzzing sound each time they open to fill the ice maker.
- I Drain pan** (not removable) Sounds of water dripping into the drain pan during the defrost cycle may be heard.
- J Condenser** May create minimal sounds from forced air.

- K Motorized damper** May produce a light humming during operation.
- L Ice dispenser** When dispensing ice, a snapping, clicking, or popping sound may be heard.

NOTE

Energy efficient foam in the refrigerator is not a sound insulator.

NOTE

During automatic defrost cycle, a red glow in the back wall vents of the freezer compartment is normal.

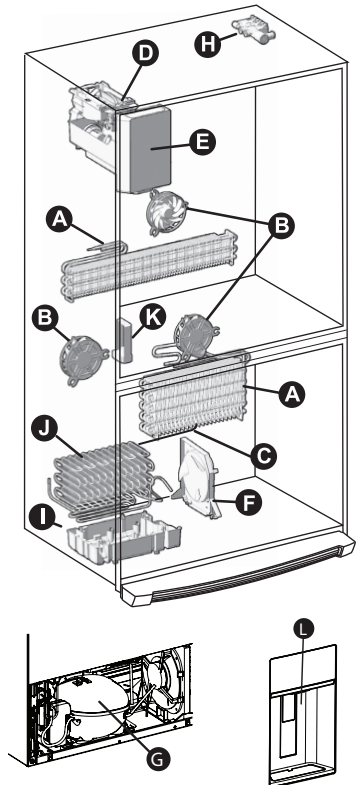

32 FILTER REPLACEMENT

PureSource Ultra II Water Filter

If you have not used the refrigerator for a period of time (during moving for example), change the filter before reinstalling the refrigerator. Order replacement filters online at Frigidaire.com, by calling 1 (800) 374-4432 or through the dealer from which the refrigerator was purchased. We recommend replacing filters at least once every 6 months.

Here is the product number to request when ordering:

**PureSource Ultra II™ Water Filter
EPTWFOU1**



NOTE

When ordering replacement filters, please reorder the same filter type that is currently in the refrigerator.

*Find the [Performance Data Sheet](#) located in the **Guides and Manuals** section for your specific water filter on Frigidaire.com.

More about the Advanced Water Filter



Certified by IAPMO R&T against NSF/ANSI Standards 42, 53, 401, CSA B483.1 and NSF/ANSI/CAN 372 in PureSource Ultra II systems for reduction of the claims on the Performance Data Sheet*.

Do not use with water that is microbiologically unsafe or of unknown quality without adequate disinfection before or after the system. Systems certified for cyst reduction may be used on disinfected waters that may contain filterable cysts.

Test & certification results:

- Rated Capacity - 125 gallons/473 L for **PureSource Ultra II** ice and water filter
- Rated service flow - .65 gallons per minute
- Operating Temp: Min. 33°F, Max. 100°F
- Maximum Rated Pressure - 100 lbs/in²
- Recommended Minimum Operating Pressure: 30 lbs/in²

Removing and replacing your water filter

To Remove: Pull the cover forward and the cover will drop down and allow access to the filter.

To Reinstall: Push the cover up toward the liner, and then push toward the rear of the cabinet. The filter cover will snap back into place.

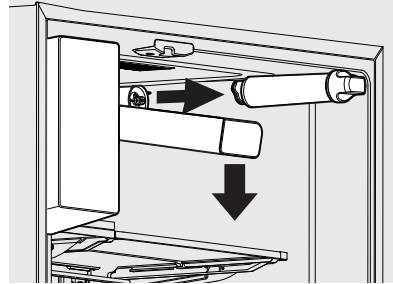

The refrigerator is equipped with a water filtering system. This system filters all dispensed drinking water, as well as the water used to produce ice. The water filter is located at the top right side of the fresh food compartment.

Change the water filter every 6 months to ensure the highest possible water quality.

Replace Water Filter on the appliance control display indicates when to replace the filter after a standard amount of water (125 gallons/473 L for **PureSource Ultra II**) has flowed through the system.

It is not necessary to turn the water supply off to change the filter. Be ready to wipe up any small amounts of water released during the filter replacement. (Instructional video of procedure can be found on Frigidaire.com.)

1. Pull forward and then push down on front edge of filter cover. Cover will tilt down and expose water filter.
2. Remove the old filter by rotating it counterclockwise (to the left) 90 degrees to release it.
3. Slide the old filter cartridge straight out of the housing and discard it.
4. Unpackage the new filter cartridge and remove any protective caps from filter before installing. Slide it into the filter housing as far as it will go with the grip end vertical.
5. Push lightly inward on the filter while rotating it clockwise (to the right). The filter will then pull itself inward as it is rotated. Rotate the filter 90 degrees until it stops and the grip end is horizontal. A very light click may be heard as the filter locks into place.
6. Press a drinking glass against the water dispenser while checking for any leaks at the filter housing. Any spurts and sputters that occur as the system purges air out of the dispenser system are normal.
7. Continue dispensing water for 3-4 minutes. It may be necessary to empty and refill the container several times.
8. To reset filter alert, press and hold the **Reset Water Filter** on the display for 3 seconds. Tone will sound once it has been reset.
9. Replace filter cover by pushing up and snapping into place.

PureAir Ultra II Air Filter

To ensure optimal filtering of refrigerator odors, change the air filter every 6 months (**Replace Air Filter** on the appliance control display indicates replacing the filter after 6 months).

Ordering your replacement air filter

To order replacement filters, please visit our online store at Frigidaire.com, by calling toll-free at 1 (800) 372-4432, or by visiting the dealer where you purchased your unit. We recommend replacing filters at least once every 6 months.

Here is the product number to request when ordering:

PureAir Ultra II™ Air Filter PAULTRA2

Replacing your air filter

The air filter is located in the top center of the fresh food compartment.

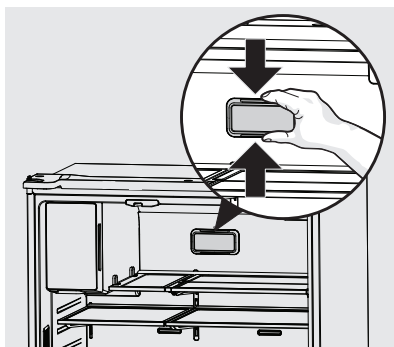

1. Remove the air filter cover by squeezing the top and bottom of the cover together and removing it from liner.
2. Remove the old filter and discard it.
3. Unpack the new filter and snap it into the filter cover. You should install the open face (carbon media) of the filter facing outward in the cover.
4. Replace the air filter cover by squeezing the sides and snapping it back into place.
5. Press and hold **Reset Air Filters** on the appliance control display for 3 seconds. When the indicator turns off, you have reset the status.

34 CARE AND CLEANING

Care and Cleaning Tips

Keeping the refrigerator clean maintains its appearance and prevents odor build-up. Wipe up any spills immediately and clean the freezer and fresh food compartments at least twice a year.

NOTE

Do not use abrasive cleaners such as window sprays, scouring cleansers, flammable fluids, cleaning waxes, concentrated detergents, bleaches, or cleansers containing petroleum products on plastic parts, interior doors, gaskets, or cabinet liners. Do not use scouring pads or other abrasive cleaning materials.

- Never use metallic scouring pads, brushes, abrasive cleaners, or strong alkaline solutions on any surface.
- Never use CHLORIDE or cleaners with bleach to clean stainless steel.
- Do not wash any removable parts in a dishwasher.

NOTE

When setting temperature controls to turn off cooling, power to lights and other electrical components will continue until the power cord is unplugged from the wall outlet.

- Always unplug the electrical power cord from the wall outlet before cleaning.
- Remove adhesive labels by hand. Do not use razor blades or other sharp instruments which can scratch the appliance surface.
- Do not remove the serial plate. Removal of the serial plate voids the warranty.
- Before moving refrigerator, raise the anti-tip brackets so the rollers will work correctly. This will prevent the floor from being damaged.

Refer to the guide on the next page for details on caring and cleaning specific areas of refrigerator.

CAUTION

- Pull the refrigerator straight out to move it. Shifting it from side to side may damage flooring. Be careful not to move the refrigerator beyond the plumbing connections.
- Damp objects stick to cold metal surfaces. Do not touch refrigerated surfaces with wet or damp hands.

IMPORTANT

When storing or moving refrigerator in freezing temperatures, be sure to completely drain the water supply system. Failure to do so could result in water leaks when the refrigerator is put back into service. Contact a service representative to perform this operation.

Vacation and moving tips

Occasion Tips

- Short Vacations**
 - Leave refrigerator operating during vacations of 3 weeks or less.
 - Use all perishable items from refrigerator compartment.
 - Turn automatic ice maker off and empty ice bucket, even if only away a few days.
- Long Vacations**
 - Remove all food and ice if leaving for one month or more.
 - Turn the cooling system off (see **CONTROLS AND SETTINGS** for the location of **On/Off**) and disconnect the power cord.
 - Turn the water supply valve to closed.
 - Clean the interior thoroughly.
 - Leave both doors open to prevent odors and mold build-up. Block the doors open if necessary.
- Moving**
 - Unplug the unit.
 - Remove all food and ice.
 - If using a handcart, load from the side.
 - Adjust rollers all the way up to protect them during sliding or moving.
 - Pad cabinet to avoid scratching the surface.

Care & Cleaning Tips		
Part	What To Use	Tips and Precautions
Interior & Door Liners	<ul style="list-style-type: none"> • Soap and water • Baking soda and water 	Use two tablespoons of baking soda in one quart of warm water. Be sure to wring excess water out of sponge or cloth before cleaning around controls, light bulb or any electrical part.
Door Gaskets	<ul style="list-style-type: none"> • Soap and water 	Wipe gaskets with a clean soft cloth.
Drawers & Bins	<ul style="list-style-type: none"> • Soap and water 	Use a soft cloth to clean drawer runners and tracks.
Glass Shelves	<ul style="list-style-type: none"> • Soap and water • Glass cleaner • Mild liquid sprays 	Allow glass to warm to room temperature before immersing in warm water.
Exterior & Handles	<ul style="list-style-type: none"> • Soap and water • Non Abrasive Glass Cleaner 	Do not use commercial household cleaners containing ammonia, bleach or alcohol to clean handles. Use a soft cloth to clean smooth handles or exterior. DO NOT use a dry cloth to clean smooth doors.
Exterior & Handles (Stainless Steel Models Only)	<ul style="list-style-type: none"> • Soap and water • Stainless Steel Cleaners 	<p>Never use CHLORIDE or cleaners with bleach to clean stainless steel.</p> <p>Clean stainless steel front and handles with non-abrasive soapy water and a dishcloth. Rinse with clean water and a soft cloth. Use a non-abrasive stainless steel cleaner. These cleaners can be purchased at most home improvement or major department stores. Always follow manufacturer's instructions. Do not use household cleaners containing ammonia or bleach.</p> <p>NOTE: Always clean, wipe and dry with the grain to prevent scratching. Wash the rest of the cabinet with warm water and mild liquid detergent. Rinse well, and wipe dry with a clean soft cloth. Stainless steel cleaning supplies can be purchased from Frigidaire.com</p>

36 TROUBLESHOOTING

Let us help you troubleshoot your concern! This section will help you with common issues. If you need us, visit our website, chat with an agent, or call us. We may be able to help you avoid a service visit. If you do need service, we can get that started for you!

1-800-374-4432 (United States)

1-800-265-8352 (Canada)

Frigidaire.com

Frigidaire.ca

Concern	Potential Cause	Common Solution
Automatic Ice Maker		
Ice maker is not making any ice.	<ul style="list-style-type: none"> Ice maker is turned off. Refrigerator is not connected to water line or water valve is not open. The water supply line is kinked. The water filter is not seated properly. The water filter may be clogged with foreign material. 	<ul style="list-style-type: none"> Refer to Ice Maker and Controls and Settings. Fresh Food Ice Maker: Press and hold the ice maker button on the appliance control for 3 seconds to turn the ice maker on. The LED indicator illuminates to indicate the ice maker is on. Freezer Ice Maker: Press or slide the power button to turn the ice maker on. The button and LED illuminate when active. Connect the unit to the household water supply and ensure the water valve is open. Ensure that the supply line does not kink when the refrigerator is pushed into place against the wall. Remove and re-install the water filter. Be sure to seat it fully into the locked position. If water dispenses slowly or not at all, or if the filter is six months old or older, it should be replaced.
Ice maker is not making enough ice.	<ul style="list-style-type: none"> Ice maker is producing less ice than expected. The water filter may be clogged with foreign material. The water supply line is kinked. Water pressure is extremely low. Cut-off and cut-on pressures are too low (well systems only). Reverse osmosis system is in regenerative phase. 	<ul style="list-style-type: none"> The fresh food ice maker will produce approximately 3.2 to 3.7 pounds of ice every 24 hours depending on usage conditions. The freezer ice maker will produce 2 to 2.5 pounds of ice every 24 hours depending on usage conditions. If water dispenses slower than normal, or if the filter is six months old or older, it should be replaced. Ensure that the supply line does not kink when the refrigerator is pushed into place against the wall. Have someone turn up the cut-off and cut-on pressure on the water pump system (well systems only). It is normal for a reverse osmosis system to be below 20 psi during the regenerative phase.

Concern	Potential Cause	Common Solution
Automatic Ice Maker (continued)		
Ice cubes are freezing together.	<ul style="list-style-type: none"> • Ice cubes are not being used frequently enough or interruption of power for prolonged time. • Ice cubes are hollow (shells of ice with water inside). The hollow cubes break open in the bin and leak their water onto existing ice, which causes it to freeze together. 	<ul style="list-style-type: none"> • Remove ice container and discard ice. The ice maker will produce fresh supply. Ice should be used at least twice weekly to keep the cubes separated. • This generally occurs when the ice maker does not get enough water. This is usually the result of a clogged water filter or restricted water supply. Replace the water filter and if the condition still occurs, check to see if the water valve is not turned on all the way or if there is a kinked water supply line.
Dispenser (Ice & Water)		
Dispenser will not dispense ice.	<ul style="list-style-type: none"> • There is no ice in the bin to be dispensed. • The refrigerator doors are not completely closed. • Dispenser paddle has been pressed too long and the dispenser motor has overheated. 	<ul style="list-style-type: none"> • See the Ice maker is not making any ice. • Be sure the refrigerator doors are completely closed. • The motor overload protector will reset in about three minutes and then ice can be dispensed.
Ice dispenser is jammed.	<ul style="list-style-type: none"> • Ice has melted and frozen around auger due to infrequent use, temperature fluctuations, and/or power outages. • Ice cubes are jammed between ice maker and back of ice container. 	<ul style="list-style-type: none"> • Remove ice container, thaw, and empty the contents. Clean container, wipe dry, and replace in proper position. When new ice is made, dispenser should operate. • Remove ice cubes that are jamming the dispenser.
Dispenser will not dispense water.	<ul style="list-style-type: none"> • Water filter not seated properly. • Water filter is clogged. • Household water line valve is not open. 	<ul style="list-style-type: none"> • Remove and reinstall the water filter. For PureSource Ultra II, be sure to rotate it to the right until it stops and the grip end is vertical. • Replace filter cartridge. Be sure to rotate it to the right until it stops and the grip end is vertical. • Open household water line valve. See CONCERN column under Automatic Ice Maker.

38 TROUBLESHOOTING

Concern	Potential Cause	Common Solution
Dispenser (Ice & Water) (continued)		
Water not cold enough.	<ul style="list-style-type: none"> As warmer tap water goes through the filter and enters the water supply system, the chilled water is pushed through to the dispenser. Once the chilled water is used up, it will take several hours to bring the freshly replaced water to a cooler temperature. 	<ul style="list-style-type: none"> Add ice to cup or container before dispensing water. <p>Note: Only first 26 ounces are chilled.</p>
Water has an odd taste and/or odor.	<ul style="list-style-type: none"> Water has not been dispensed for an extended period of time. Unit not properly connected to cold water line. Filter needs to be replaced. 	<ul style="list-style-type: none"> Draw and discard 10-12 glasses of water to freshen the supply. Connect unit to cold water line that supplies water to the kitchen faucet. Replace water filter per instructions in this manual.
Opening/Closing Of Doors/Drawers		
Door(s) will not close.	<ul style="list-style-type: none"> Door was closed too hard, causing other door to open slightly. Refrigerator is not level. It rocks on the floor when moved slightly. Refrigerator is touching a wall or cabinet. Food/packaging is obstructing the door from closing. Flipper mullion on left fresh food door is not in the correct position. 	<ul style="list-style-type: none"> Close both doors gently. Adjust leveling legs. Ensure floor is level and solid, and can adequately support the refrigerator. Contact a carpenter to correct a sagging or sloping floor. Ensure floor is level and solid, and can adequately support the refrigerator. Contact a carpenter to correct a sagging or sloping floor. Make sure there is no food/packaging blocking the doorway. Ensure the flipper mullion is in the correct position to allow the door to close. See Flipper Mullion in INSTALLATION.
Drawers are difficult to move.	<ul style="list-style-type: none"> Food is touching shelf on top of drawer. Track that drawers slide on is dirty. 	<ul style="list-style-type: none"> Remove top layer of items in drawer. Ensure drawer is properly installed on track. Clean drawer, rollers, and track. See CARE AND CLEANING.

Concern	Potential Cause	Common Solution
Running of Refrigerator		
Compressor does not run.	<ul style="list-style-type: none"> • Refrigerator is in defrost cycle. • Plug at electrical outlet is disconnected. • House fuse blown or tripped circuit breaker. • Power outage. 	<ul style="list-style-type: none"> • This is normal for a fully automatic defrost refrigerator. The defrost cycle occurs periodically, lasting about 30 minutes. • Ensure plug is tightly pushed into outlet. • Check/replace fuse with a 15 amp time-delay fuse. Reset circuit breaker. • Check house lights. Call local electric company.
Refrigerator seems to run too much or too long.	<ul style="list-style-type: none"> • The variable speed compressor is designed to run 100% of the time except during the defrost cycle. At times it will run faster, such as after a defrost cycle. 	<ul style="list-style-type: none"> • It is normal for the compressor to run continuously except during defrost mode.
Digital Temperature Setting Display		
Digital temperature displays an error.	<ul style="list-style-type: none"> • Electronic control system has detected a performance problem. 	<ul style="list-style-type: none"> • Contact Electrolux Customer Care for assistance with any errors or codes flashing in the display by calling 1-800-374-4432.
Water/Moisture/Frost Inside Refrigerator		
Moisture collects on inside of refrigerator walls.	<ul style="list-style-type: none"> • Weather is hot and humid. • Flipper mullion 	<ul style="list-style-type: none"> • The rate of frost buildup and internal sweating increases. • Adjust flipper mullion. (See Flipper Mullion in INSTALLATION.)
Water collects on bottom side of drawer cover.	<ul style="list-style-type: none"> • Vegetables contain and give off moisture. 	<ul style="list-style-type: none"> • It is not unusual to have moisture on the bottom side of the cover. • Both crispers contain an automatic humidity control, which should adjust automatically to the varying levels of moisture inside the drawer without creating additional condensation or drying out the air inside the crisper drawer, works with various types of produce. If excess moisture is noticed, check to verify humidity membrane is not damaged and replace as necessary.
Water collects in bottom of drawer.	<ul style="list-style-type: none"> • Washed vegetables and fruit drain while in the drawer. 	<ul style="list-style-type: none"> • Dry items before putting them in the drawer. Water collecting in bottom of drawer is normal.

Concern	Potential Cause	Common Solution
Water/Moisture/Frost Outside Refrigerator		
Moisture collects on outside of refrigerator or between doors.	<ul style="list-style-type: none"> • Weather is humid. 	<ul style="list-style-type: none"> • This is normal in humid weather. When humidity is lower, the moisture should disappear.
Food/Drinks in Fresh Food Compartment/Custom-Flex Drawer		
Food is freezing.	<ul style="list-style-type: none"> • Temperature setting is too low. • Temperature sensor is covered by food (right side of fresh food area). • Food is covering the air ports. 	<ul style="list-style-type: none"> • Move the setting to a higher degree. • Allow space for air flow to the sensor. • Allow space between the air ports and the food.

Your appliance is covered by a one year limited warranty. For one year from your date of delivery, Electrolux will pay all costs for repairing or replacing any parts of this appliance that prove to be defective in materials or workmanship when such appliance is installed, used and maintained in accordance with the provided instructions.

Exclusions

This warranty does not cover the following:

1. Products with original serial numbers that have been removed, altered or cannot be readily determined.
2. Product that has been transferred from its original owner to another party or removed outside the USA or Canada.
3. Rust on the interior or exterior of the unit.
4. Products purchased "as-is" are not covered by this warranty.
5. Food loss due to any Appliance or freezer failures.
6. Products used in a commercial setting.
7. Service calls which do not involve malfunction or defects in materials or workmanship, or for appliances not in ordinary household use or used other than in accordance with the provided instructions.
8. Service calls to correct the installation of your appliance or to instruct you how to use your appliance.
9. Expenses for making the appliance accessible for servicing, such as removal of trim, cupboards, shelves, etc., which are not a part of the appliance when it is shipped from the factory.
10. Service calls to repair or replace appliance light bulbs, air filters, water filters, other consumables, or knobs, handles, or other cosmetic parts.
11. Surcharges including, but not limited to, any after hour, weekend, or holiday service calls, tolls, ferry trip charges, or mileage expense for service calls to remote areas, including the state of Alaska.
12. Damages to the finish of appliance or home incurred during installation, including but not limited to floors, cabinets, walls, etc.
13. Damages caused by: services performed by unauthorized service companies; use of parts other than genuine Electrolux parts or parts obtained from persons other than authorized service companies; or external causes such as abuse, misuse, inadequate power supply, accidents, fires, or acts of God.

DISCLAIMER OF IMPLIED WARRANTIES; LIMITATION OF REMEDIES

CUSTOMER'S SOLE AND EXCLUSIVE REMEDY UNDER THIS LIMITED WARRANTY SHALL BE PRODUCT REPAIR OR REPLACEMENT AS PROVIDED HEREIN. CLAIMS BASED ON IMPLIED WARRANTIES, INCLUDING WARRANTIES OF MERCHANTABILITY OR FITNESS FOR A PARTICULAR PURPOSE, ARE LIMITED TO ONE YEAR OR THE SHORTEST PERIOD ALLOWED BY LAW, BUT NOT LESS THAN ONE YEAR. ELECTROLUX SHALL NOT BE LIABLE FOR CONSEQUENTIAL OR INCIDENTAL DAMAGES SUCH AS PROPERTY DAMAGE AND INCIDENTAL EXPENSES RESULTING FROM ANY BREACH OF THIS WRITTEN LIMITED WARRANTY OR ANY IMPLIED WARRANTY. SOME STATES AND PROVINCES DO NOT ALLOW THE EXCLUSION OR LIMITATION OF INCIDENTAL OR CONSEQUENTIAL DAMAGES, OR LIMITATIONS ON THE DURATION OF IMPLIED WARRANTIES, SO THESE LIMITATIONS OR EXCLUSIONS MAY NOT APPLY TO YOU. THIS WRITTEN WARRANTY GIVES YOU SPECIFIC LEGAL RIGHTS. YOU MAY ALSO HAVE OTHER RIGHTS THAT VARY FROM STATE TO STATE.

If You Need Service

Keep your receipt, delivery slip, or some other appropriate payment record to establish the warranty period should service be required. If service is performed, it is in your best interest to obtain and keep all receipts. Service under this warranty must be obtained by contacting Electrolux at the addresses or phone numbers below.

This warranty only applies in the USA and Canada. In the USA, your appliance is warranted by Electrolux Major Appliances North America, a division of Electrolux Home Products, Inc. In Canada, your appliance is warranted by Electrolux Canada Corp. Electrolux authorizes no person to change or add to any obligations under this warranty. Obligations for service and parts under this warranty must be performed by Electrolux or an authorized service company. Product features or specifications as described or illustrated are subject to change without notice.

USA

1-800-374-4432

Frigidaire

10200 David Taylor Drive
Charlotte, NC 28262



Electrolux

Canada

1.800.265.8352

Electrolux Canada Corp.

5855 Terry Fox Way

Mississauga, Ontario, Canada

L5V 3E4

FRIGIDAIRE®

welcome **home**

Our home is your home. Visit us if you need help with any of these things:



owner support



accessories



service



registration

(See your registration card for more information.)

Frigidaire.com
1-800-374-4432

Frigidaire.ca
1-800-265-8352