



40CC POCKET BIKE

ITEM# 99701 (BLUE), 99703 (BLACK.), 99706 (FLAME RED)



OWNER'S MANUAL AND SAFETY INSTRUCTIONS

SAVE THIS MANUAL. KEEP THIS MANUAL FOR SAFETY WARNINGS, PRECAUTIONS, ASSEMBLY, OPERATION, INSPECTION, MAINTENANCE AND CLEANING PROCEDURES. WRITE THE PRODUCT'S SERIAL NUMBER ON THE BACK OF THE MANUAL, OR THE MONTH AND YEAR OF PURCHASE IF PRODUCT HAS NO SERIAL NUMBER

FOR QUESTIONS, PLEASE CALL CUSTOMER SERVICE: 909.628.0880

SAFETY WARNINGS

WARNING

This owner's manual contains important information. Each rider of the mini bike must read this owner's manual thoroughly before riding the mini bike for the first time and must always follow all of the instructions outlined in this manual. This

manual must remain with the vehicle if the vehicle is transferred to a new owner. Do not discard this owner's manual as it must be reviewed by each rider prior to his or her operation of the vehicle. If a minor is operating the vehicle, it is the responsibility of the minor's guardian to ensure that the minor understands the information contained in this manual. This manual contains the latest product information available before printing. Due to product improvements or production changes, there could be discrepancies between the information contained in this owner's manual and actual product specifications. XtremePowerUS reserves the right to make changes to its products at any time without notice and without obligation to make the same or similar changes to any vehicle previously built or sold.

It is the responsibility of any rider of this vehicle to be familiar with and fully comply with all laws, rules, and regulations governing the operation of this vehicle. Laws vary by jurisdiction. XtremePowerUS has no responsibility or liability for the costs to comply with all applicable laws and regulations or for mini bike damage or human injury resulting from an owner or operator's failure to follow all relevant laws and regulations. These laws include, but are not limited to:

»»**Vehicle Operation Laws:** It is illegal to operate this off-road vehicle on public streets, roads, and highways. It is illegal to operate this vehicle under the influence of drugs or alcohol, even on private property. Other vehicle operation laws might apply in your area.

»»**Vehicle Title & Registration Laws:** You may need to title and/or register your new mini bike with one or more state or municipal government agencies. You are solely responsible for titling and/or registering your mini bike and for all related costs. Keep your mini bike's Certificate of Origin; it may be required to title and/or register your vehicle.

»»**Vehicle Modification Laws:** Do not modify your mini bike or attach aftermarket accessories. Modifications to the carburetor and exhaust systems are a violation of the law and are subject to prosecution by the Environmental Protection Agency.

»»**Vehicle Maintenance Laws:** Always follow all relevant vehicle maintenance laws, which include, but are not limited to, laws regulating the handling and disposal of flammable and dangerous materials such as gasoline and oil.











 **WARNING:** Never allow children under the age of 16 to ride the mini bike. The mini bike is designed for riders who are 16 or older. Riders younger than age 16 should not operate the mini bike.

 **WARNING:** Never allow unsupervised or unqualified minors to ride the bike. If the operator of the mini bike is a minor, the rider's guardian is responsible 1) for ensuring that the rider meets the physical and developmental levels necessary to safely ride the bike and 2) for supervising the minor while he or she is riding the mini bike.

 **WARNING:** Always wear protective safety gear while riding the mini bike. Protective safety gear includes, but is not limited to, a Department of Transportation approved full-face motorcycle helmet with a chin strap, goggles, boots, gloves, long riding pants with hip and knee pads, and a long sleeved riding jersey with elbow, chest, and shoulder pads.

 **WARNING:** Always secure hair while riding the mini bike. Loose hair has the potential to get caught in the mini bike. Always keep hair tightly secured while operating the bike.

SAFETY WARNINGS

-  **WARNING:** Never operate the bike under the influence of alcohol or drugs. The use of alcohol and/or drugs will impair the rider's ability to safely operate the mini bike.
-  **WARNING:** Never operate the mini bike with a passenger. The mini bike is designed for one rider at a time.
-  **WARNING:** Never ride the mini bike on hard surfaces. The mini bike's tires are designed for operation in dirt, gravel, or similar materials and are not stable on any hard surfaces including, but not limited to, concrete or asphalt.
-  **WARNING:** Never ride the mini bike alone. Because unexpected situations can occur, always ride in proximity of your base and of other people who can provide assistance in case of a problem.
-  **WARNING:** Never ride the mini bike if it is not in proper riding condition. Always inspect your mini bike before you ride to ensure that it is in proper riding condition. If you have any indication that your mini bike is not running correctly, stop riding immediately. Do not ride your mini bike back to your base.
-  **WARNING:** Ride within your skill level at comfortable speeds. Be cautious of potential hazards and difficult terrain. Exercise extra caution in muddy or wet riding conditions. Always keep both hands and feet on the handlebars and foot pegs. Do not brake or accelerate while turning. Do not attempt tricks or stunts or go off jumps.
-  **WARNING:** Never operate the mini bike in an enclosed space with poor ventilation. The mini bike's exhaust gas contains poisonous carbon monoxide which can collect rapidly in an enclosed area and result in illness or death.
-  **WARNING:** Never modify the mini bike or attach after-market accessories. Modifications and after-market accessories reduce the rider's ability to control and ride the mini bike safely. XtremePowerUS is not liable for any damage or injury caused by any after-market accessory.
-  **WARNING:** Always perform the necessary maintenance on the vehicle. Failure to perform necessary maintenance on the vehicle could result in harm or fatal injury to the operator or others.
-  **WARNING:** Always exercise caution while servicing the mini bike. Performing most maintenance procedures on the mini bike involves handling potentially dangerous and flammable materials such as oil and gasoline. Recognize the risk that injury could potentially occur while you are servicing your mini bike and always use good judgment. Wear the necessary protective gear. Keep flames and cigarettes away from the mini bike.
-  **WARNING:** Never perform maintenance on the vehicle while it is running. To reduce the risk of potential harm or burns from hot or moving parts, always ensure that the engine stop switch and the fuel valve lever are both in the "off" position before performing maintenance on your mini bike. Never touch any of the mini bike's parts while the mini bike is running.

PROP 65 WARNING: Operating, servicing and maintaining a passenger vehicle or off-highway motor vehicle can expose you to chemicals including engine exhaust, carbon monoxide, phthalates, and lead, which are known to the State of California to cause cancer and birth defects or other reproductive harm. To minimize exposure, avoid breathing exhaust, do not idle the engine except as necessary, service your vehicle in a well-ventilated area and wear gloves or wash your hands frequently when servicing your vehicle.

SAVE THESE WARNINGS.

BIKE DIAGRAM

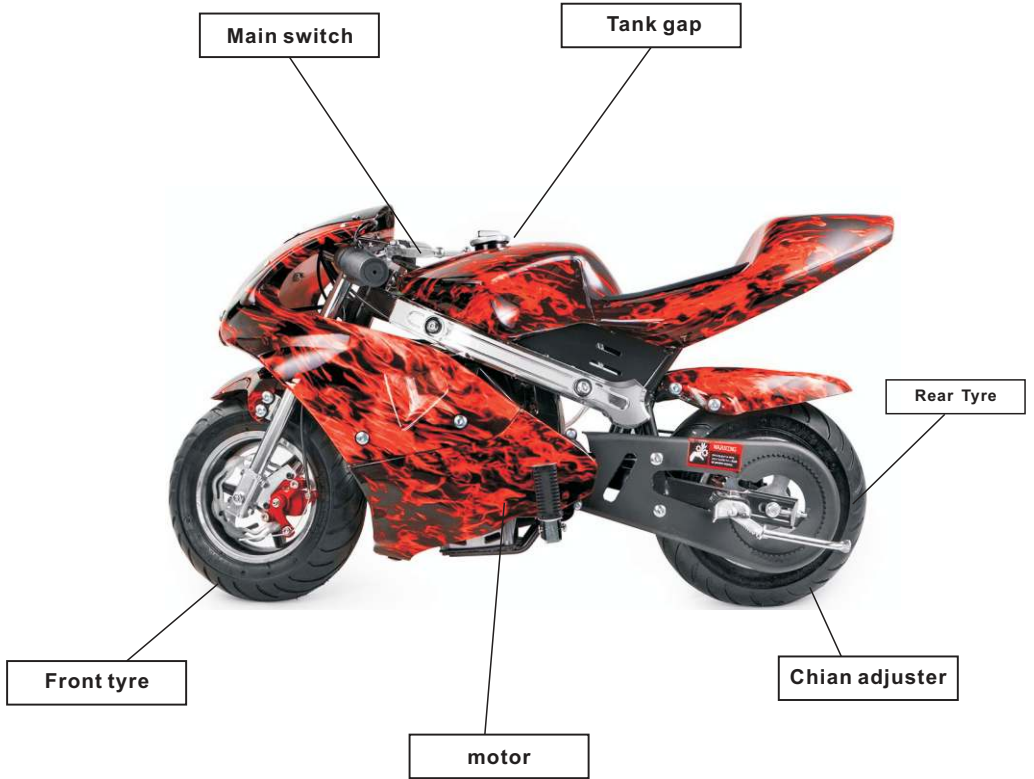

ASSEMBLY

PACKAGE CONTENTS

Your motorcycle comes with the following items in the box. Please locate all of the following:

1. Motorcycle
2. Tool Kit
3. Product Handbook

GETTING STARTED

Please read and understand these instructions and the OPERATING PROCEDURES section, prior to starting or riding your Motorcycle.

Fueling

This is a 4-stroke engine.

Only run the engine using gasoline >#90.

PLEASE READ OPERATING PROCEDURES BEFORE FUELING.

1. Make sure that the engine is off!
2. Slowly open the GAS CAP. so that possible over-pressure disappears.
3. Clean the tank cap area to make sure that it is free from excess dirt and debris. Make sure that no dirt falls into the gas tank.
4. After fueling, replace the GAS CAP and tighten.

Starting - Pull Start

Move at least 10 feet away from where you filled up the gas.

1. Set the CHOKE LEVER to the CHOKED (UP) position.
2. Pull the RECOIL STARTER briskly, making sure to hold the handle in your grasp.
★Note: Do not allow it to snap back, let it back slowly. You may want to give it a little throttle by gently squeezing the GAS LEVER.
3. It may be necessary to repeat step 6 several times until the motor starts.

When starting the motorcycle for the first time, it may be necessary to pull the starter handle multiple times until it starts.

★This is because the gas needs to be drawn into the carburetor.

After engine is started, let it warm up for 2-3minutes before riding.

Riding

1. Make sure that all of the exposed bolts and screws are tightened.
2. Raise the kickstand to its upright position.
3. Make sure the engine is running.
4. Put one foot on the deck of the motorcycle. While pushing off with the other foot, gently rotate the THROTTLE toward the rider on the right side of the handlebars. The motorcycle will begin to move on its own power. Control the speed by rotating the hand throttle either towards the rider or away.

Braking

1. To brake, release the hand throttle and depress the hand brake levers (on the left/right side of the handlebars).

Stopping/Shutting down

2. Gradually decrease the engine speed to idle and turn off the kill switch on handlebar tube. This will turn the engine OFF.

★NOTE: If the lever is pulled aggressively, the locking spring may become stretched and then the steering will not lock into position, It is also advisable to ensure the handlebar locks firmly, prior to riding.

WARNING:

- Always shut the engine off before refueling.
- Slowly open the fuel tank, so that possible over-pressure disappears.
- Before fueling, clean the tank cap area carefully, to insure that no dirt falls into the tank. Make sure that the fuel is well mixed by shaking the container.
- Tighten the fuel cap carefully, after fueling.
- Always move the unit at least 10 feet from the fueling area before starting.

Starting

Pull Start Method:

- a. Set the CHOKE LEVER to the CLOSED (UP) position.
- b. Pull the pull starter handle briskly, making sure to keep the handle in your grasp, and not allowing it to snap back.
- c. Once the engine is running, move the CHOKE LEVER to the RUN(DOWN) position.

Note!

At this stage, if the engine does not start, repeat the starting procedure.

- After starting the engine, allow the engine 2-3 minutes to warm up prior to riding.

Stopping

- Gradually decrease the engine speed to an idle speed and turn off main switch.

CARBURETOR ADJUSTMENT

◆ WARNING!

Never start the engine without the complete clutch cover assembled! Otherwise the clutch can come loose and cause injuries.

When the engine is tested at the factory, the Carburetor is basically adjusted. Further adjustment may be required from time to time, depending on climate and altitude.

WARNING!

When the engine is idling, under no circumstance should your motorcycle be moving. If the motorcycle continues to move after idle speed adjustment, contact service center.

BRAKING SYSTEM

The motorcycle uses both a front wheel disc/caliper braking system activated by a hand brake lever on each side of the handlebar. Squeezing the hand brake lever with your left hand activates the rear brake. Make sure to release the HAND THROTTLE GRIP when engaging the brakes.

Practice braking on a smooth, dry surface to get used to the feel of the braking system. Braking distance is affected by wet conditions and loose and uneven riding surfaces.

ADJUSTING THE BREAKS

The Brakes on the motorcycle should come fully adjusted from the factory. However, it may be necessary to adjust the brake from time to time.

1. With one hand, depress the brake caliper using your thumb and forefinger
2. With the other hand, adjust the tension screw on the brake line.
 - a. Turn the tension screw clockwise to loosen the brake.
 - b. Turn the tension screw counterclockwise to tighten brake.

Squeaky Brakes

The brakes may squeak before they are broken in. This is normal and will not affect the function or performance of the brakes. With continued use the squeak should go away.

ADJUSTING THE CHAINS

The chains will come adjusted from the factory. However, it may be necessary to adjust the sprockets from time to time. The chain must be well aligned with the sprockets otherwise they may start to rub and chafe. Which will result in shortened chain life.

How tight should the chain be?

- If the chain is skipping or jumping on the pulley teeth, it is too loose and may be harmful.
- If the chain is making a humming sound when the wheel is turning, it is too tight and may cause the chain to snap.
- The correct tension is achieved by adjusting the chain from its loose position to when it becomes lightly tense.



To tighten the chains:

1. Slightly loosen the two Axle bolts then slowly adjust the two chain adjusting screws on each side of the rear tire until the chain reaches the proper tension.
2. Occasionally rotate the rear tire to make sure chain is aligned.
3. Finally lock and tighten the rear axle bolts prior to riding.

MAINTENANCE

MAINTENANCE SCHEDULE

Proper care of your motorcycle will insure optimal performance and a longer life span. The following are a few maintenance suggestions that will keep your motorcycle running in top condition:

Daily Maintenance

Perform each time you ride your motorcycle

- **Clean the exterior of the unit with a soft, damp rag.**
- **Check that all nuts and bolts are securely tightened.**

Weekly/Monthly Maintenance

- Check the pull starter, especially the cord and return spring.
- Remove the spark plug and check the electrode gap. Adjust it to 0.6mm, or change the spark plug.
- Clean the cooling fins on the cylinder head and check that the air intake at the starter is not clogged.
- Clean the air filter.

Gas pocket STARTING PROCEDURE

To start the motor needs three things:

- Gas
- A spark
- Cylinder compression

1. Put gas in the tank. Using an approved gas container, add at least a gallon of gas to the gas tank.
2. move the choke lever to the "on" position, (make sure fuel line is free of air)
3. pull the recoils, the choke should be up to start a cold engine.

When starting your motor for the first time, open the throttle a couple of times to get the gas flowing into the carburetor and the jets inside. Don't over pump the gas it may flood the engine (need to wait 10mins to restart if engine is flooded) After the engine "pops" the first time, then give it a little throttle and allow it to idle till it warms up.

After engine warms up, turn off choke, slowly ride off and check to make sure tires are at the proper inflation and all systems operate.

PARTS EXPLODED VIEW

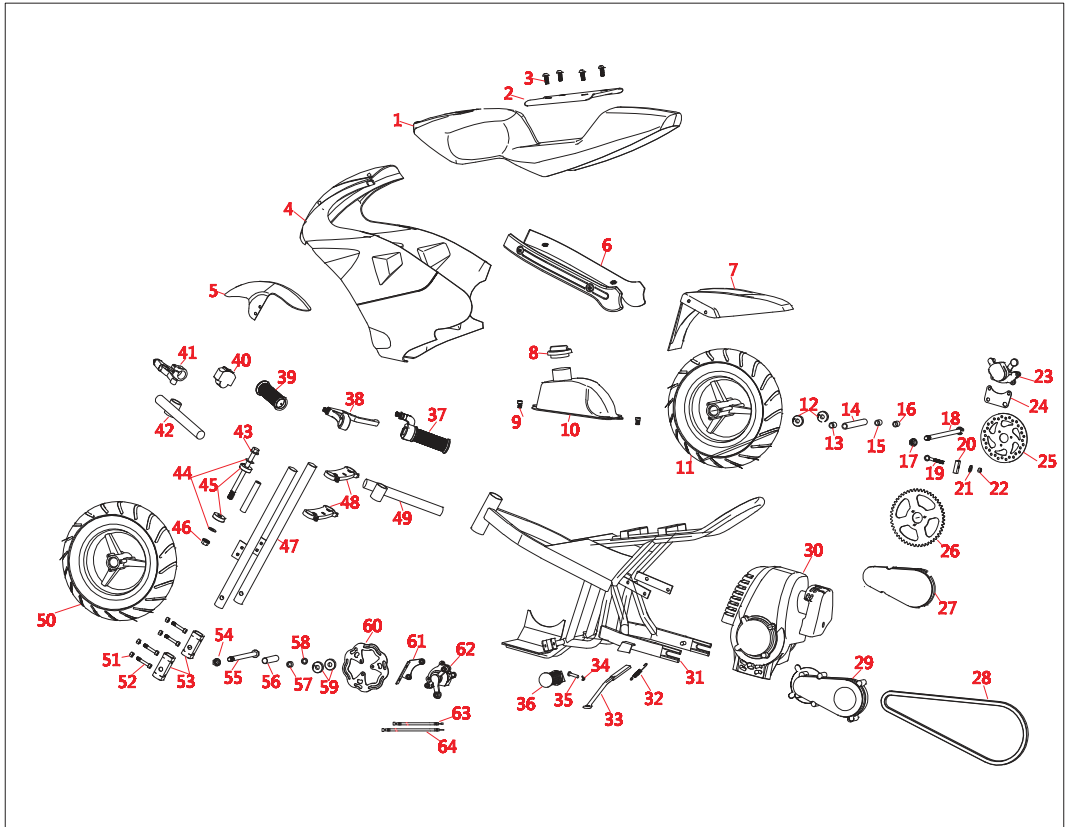

PARTS LIST

Item	Description	Item	Description
1	Fuel tank holder	33	Kickstand
2	Seat	34	Cotter pin
3	The screw of seat	35	Safety pin
4	Front wind shield	36	Pedal
5	Front Fender	37	Accelerator handle
6	Frame trim strip	38	The brake right
7	Back Fender	39	The grip left
8	Fuel tank cap	40	Throttle switch
9	The screw of fuel tank	41	The brake left
10	Fuel tank	42	Then hand lever left
11	Back tire	43	Screw pole
12	Bearing 6000	44	Gasket
13	Spacer bush	45	Bearing 6200
14	Spacer bush	46	Screw nut
15	Spacer bush	47	Straight Pole
16	Spacer bush	48	Connecting Plate
17	Screw nut	49	Then hand lever right
18	Screw pole	50	Front tire
19	Jack	51	Screw nut
20	Trim strip	52	Screw
21	Flat Gasket	53	Aluminum head
22	Screw nut	54	Screw nut
23	Brake	55	Screw pole
24	Brake fixing flat	56	Spacer bush
25	Brake pad	57	Spacer bush
26	Flywheel	58	Spacer bush
27	Chain cover	59	Bearing 6000
28	Chain	60	Brake pad
29	Reduction gearbox	61	The front brake fixing plate
30	Engine	62	Brake
31	Bike rack	63	Brake line
32	The spring of kickstand	64	Throttle line

DISCLAIMER

PLEASE READ THE FOLLOWING CAREFULLY

THE MANUFACTURER AND/OR DISTRIBUTOR HAS PROVIDED THE PARTS LIST AND ASSEMBLY DIAGRAM IN THIS MANUAL AS A REFERENCE TOOL ONLY. NEITHER THE MANUFACTURER OR DISTRIBUTOR MAKES ANY REPRESENTATION OR WARRANTY OF ANY KIND TO THE BUYER THAT HE OR SHE IS QUALIFIED TO MAKE ANY REPAIRS TO THE PRODUCT, OR THAT HE OR SHE IS QUALIFIED TO REPLACE ANY PARTS OF THE PRODUCT. IN FACT, THE MANUFACTURER AND/OR DISTRIBUTOR EXPRESSLY STATES THAT ALL REPAIRS AND PARTS REPLACEMENTS SHOULD BE UNDERTAKEN BY CERTIFIED AND LICENSED TECHNICIANS, AND NOT BY THE BUYER. THE BUYER ASSUMES ALL RISK AND LIABILITY ARISING OUT OF HIS OR HER REPAIRS TO THE ORIGINAL PRODUCT OR REPLACEMENT PARTS THERETO, OR ARISING OUT OF HIS OR HER INSTALLATION OF REPLACEMENT PARTS THERETO.

Record Product's Serial Number Here: _____

Note: If product has no serial number, record month and year of purchase instead.

Note: Some parts are listed and shown for illustration purposes only and are not available individually as replacement parts.

The material in this manual is for informational purposes only. The product(s) it describes are subject to change without prior notice, due to the manufacturer's continuous development program. XtremePowerUS makes no representations or warranties with respect to this manual or with respect to the products described herein. XtremePowerUS shall not be liable for any damages, losses, costs or expenses, direct, indirect or incidental, consequential or special, arising out of, or related to the use of this material or the products described herein.

Questions, issues or missing parts?

Before returning to your retailer, our customer service team is here to help.



Call Us: 909.628.0880

Email Us: customer@xtremepowerusa.com

Hours of Operation: 9am - 3pm PST Monday - Friday

MADE IN CHINA