



Indigo Ice Machines

Installation, Operation and Maintenance Manual

This manual is updated as new information and models are released. Visit our website for the latest manual.



Safety Notices

Safety Notices

Read these precautions to prevent personal injury:

- Read this manual thoroughly before operating, installing or performing maintenance on the equipment. Failure to follow instructions in this manual can cause property damage, injury or death.
- Routine adjustments and maintenance procedures outlined in this manual are not covered by the warranty.
- Proper installation, care and maintenance are essential for maximum performance and trouble-free operation of your equipment.
Visit our website www.manitowocice.com for manual updates, translations, or contact information for service agents in your area.
- This equipment contains high voltage electricity and refrigerant charge. Installation and repairs are to be performed by properly trained technicians aware of the dangers of dealing with high voltage electricity and refrigerant under pressure. The technician must also be certified in proper refrigerant handling and servicing procedures. All lockout and tag out procedures must be followed when working on this equipment.
- This equipment is intended for indoor use only. Do not install or operate this equipment in outdoor areas.

DEFINITIONS

DANGER

Indicates a hazardous situation that, if not avoided, will result in death or serious injury. This applies to the most extreme situations.

Warning

Indicates a hazardous situation that, if not avoided, could result in death or serious injury.

Caution

Indicates a hazardous situation that, if not avoided, could result in minor or moderate injury.

Notice

Indicates information considered important, but not hazard-related (e.g. messages relating to property damage).

NOTE: Indicates useful, extra information about the procedure you are performing

Warning

Follow these precautions to prevent personal injury during installation of this equipment:

- Installation must comply with all applicable equipment fire and health codes with the authority having jurisdiction.
- To avoid instability the installation area must be capable of supporting the combined weight of the equipment and product. Additionally the equipment must be level side to side and front to back.
- Ice machines require a deflector when installed on an ice storage bin. Prior to using a non-OEM ice storage system with this ice machine, contact the bin manufacturer to assure their ice deflector is compatible.
- Remove all removable panels before lifting and installing and use appropriate safety equipment during installation and servicing. Two or more people are required to lift or move this appliance to prevent tipping and/or injury.
- Do not damage the refrigeration circuit when installing, maintaining or servicing the unit.
- Connect to a potable water supply only.
- This equipment contains refrigerant charge. Installation of the line sets must be performed by a properly trained and EPA certified refrigeration technician aware of the dangers of dealing with refrigerant charged equipment.
- Legs or casters must be installed and the legs/casters must be screwed in completely. When casters are installed the mass of this unit will allow it to move uncontrolled on an inclined surface. These units must be tethered/secured to comply with all applicable codes. Swivel casters must be mounted on the front and rigid casters must be mounted on the rear. Lock the front casters after installation is complete.
- Some 50 Hz models may contain up to 150 grams of R290 (propane) refrigerant. R290 (propane) is flammable in concentrations of air between approximately 2.1% and 9.5% by volume (LEL lower explosion limit and UEL upper explosion limit). An ignition source at a temperature higher than 470°C is needed for a combustion to occur. Refer to nameplate to identify the type of refrigerant in your equipment. Only trained and qualified personnel aware of the dangers are allowed to work on the equipment.

⚠ Warning

Follow these electrical requirements during installation of this equipment.

- All field wiring must conform to all applicable codes of the authority having jurisdiction. It is the responsibility of the end user to provide the disconnect means to satisfy local codes. Refer to rating plate for proper voltage.
- This appliance must be grounded.
- This equipment must be positioned so that the plug is accessible unless other means for disconnection from the power supply (e.g., circuit breaker or disconnect switch) is provided.
- Check all wiring connections, including factory terminals, before operation. Connections can become loose during shipment and installation.

⚠ Warning

Follow these precautions to prevent personal injury while operating or maintaining this equipment:

- Read this manual thoroughly before operating, installing or performing maintenance on the equipment. Failure to follow instructions in this manual can cause property damage, injury or death.
- Crush/Pinch Hazard. Keep hands clear of moving components. Components can move without warning unless power is disconnected and all potential energy is removed.
- Moisture collecting on the floor will create a slippery surface. Clean up any water on the floor immediately to prevent a slip hazard.
- Objects placed or dropped in the bin can affect human health and safety. Locate and remove any objects immediately.
- Never use sharp objects or tools to remove ice or frost. Do not use mechanical devices or other means to accelerate the defrosting process.
- When using cleaning fluids or chemicals, rubber gloves and eye protection (and/or face shield) must be worn.

⚠ DANGER

Do not operate equipment that has been misused, abused, neglected, damaged, or altered/modified from that of original manufactured specifications. This appliance is not intended for use by persons (including children) with reduced physical, sensory or mental capabilities, or lack of experience and knowledge, unless they have been given supervision concerning use of the appliance by a person responsible for their safety. Do not allow children to play with, clean or maintain this appliance without proper supervision.

⚠ DANGER

Follow these precautions to prevent personal injury during use and maintenance of this equipment:

- It is the responsibility of the equipment owner to perform a Personal Protective Equipment Hazard Assessment to ensure adequate protection during maintenance procedures.
- Do Not Store Or Use Gasoline Or Other Flammable Vapors Or Liquids In The Vicinity Of This Or Any Other Appliance. Never use flammable oil soaked cloths or combustible cleaning solutions for cleaning.
- All covers and access panels must be in place and properly secured when operating this equipment.
- Risk of fire/shock. All minimum clearances must be maintained. Do not obstruct vents or openings.
- Failure to disconnect power at the main power supply disconnect could result in serious injury or death. The power switch DOES NOT disconnect all incoming power.
- All utility connections and fixtures must be maintained in accordance with the authority having jurisdiction.
- Turn off and lockout all utilities (gas, electric, water) according to approved practices during maintenance or servicing.
- Units with two power cords must be plugged into individual branch circuits. During movement, cleaning or repair it is necessary to unplug both power cords.
- Never use a high-pressure water jet for cleaning on the interior or exterior of this unit. Do not use power cleaning equipment, steel wool, scrapers or wire brushes on stainless steel or painted surfaces.
- Two or more people are required to move this equipment to prevent tipping.
- Locking the front casters after moving is the owner's and operator's responsibility. When casters are installed, the mass of this unit will allow it to move uncontrolled on an inclined surface. These units must be tethered/secured to comply with all applicable codes.
- The on-site supervisor is responsible for ensuring that operators are made aware of the inherent dangers of operating this equipment.
- Do not operate any appliance with a damaged cord or plug. All repairs must be performed by a qualified service company.

Table of Contents

Safety Notices

Safety Notices	3
----------------------	---

Section 1

General Information

Ice Deflector	7
Bin Level Accessory Kit	7
Bin Installation	7
Control Panel Bezel.....	7
Top Air Discharge Kit.....	7
LuminIce® II.....	7
How To Read A Model Number.....	8

Section 2

Installation

Installation	9
Location Requirements.....	9
Installation Requirements	9
Ice Machine Heat of Rejection	9
Bin Installation	11
Air Baffle	11
Electrical Requirements.....	12
Maximum Breaker Size & Minimum Circuit Amperage Chart	13
ICVD Interconnecting Wiring	15
ICVD Transformer Wiring.....	15
Remote Condenser Wiring.....	15
Water Supply and Drain Line Sizing/Connections.....	16
Cooling Tower Applications (Water-Cooled Models)	16
Drain Connections	17
Remote Condenser and Remote Condensing Unit Refrigeration System Installation	18
Calculating Remote Condenser & Remote Condensing Unit Installation Distances.....	19
Position Bin Thermostat Probe	24
Starting the Ice Machine.....	25
Set the Language, Time and Date.....	25
Remove Ice Thickness Probe Shipping Brackets	26
Starting the Ice Machine.....	26
Minimum/Maximum Slab weight	26
Ice Thickness Check	26



**Section 3
Operation**

Control Panel Features 27
 Buttons..... 27
 Display Panel 27
Overview of Menu Navigation 28
Display Panel Navigation 29
Alerts and Messages..... 29
Main Menu 30
 Machine Info Menu..... 30
 Password Entry 30
 Set-Up Menu 31
 Energy Saver Menu 34
Service Menu 36
Ice Making Sequence of Operation 37
 Operational Checks 38
 Minimum/Maximum Slab weight 38
Ice Thickness Check 38

**Section 4
Maintenance**

Cleaning and Sanitizing..... 39
Cleaning/Sanitizing Procedure..... 40
 Cleaning Procedure 40
 Sanitizing Procedure 41
Parts Removal for Cleaning/Sanitizing 42
 Single Evaporator Ice Machines 42
 Multiple Evaporator Ice Machines 43
Preventative Maintenance Cleaning Procedure..... 44
Cleaning the Condenser Filter 44
Cleaning the Condenser..... 44

**Section 5
Troubleshooting**

Before Calling for Service Checklist 45
Safety Limit Feature..... 46



Section 1

General Information

Ice Deflector

An ice deflector is required when the ice machine is installed on a bin. An ice deflector is not required when the ice machine is installed on a dispenser.

Bin Level Accessory Kit

The bin level accessory connects to the circuit board and allows bin level adjustment of Indigo ice machines on B model bins. Installation instructions are included with the accessory. A bin level sensor is required to set a lower level of ice in the bin.

Bin Installation

- All ice machines installed on a bin require an ice deflector.
- Manitowoc bins have a deflector installed and require no modifications when used with a forward-facing evaporator.
- Ice machines with multiple evaporators require a deflector kit.
- Align sides and back of ice machine with sides and back of bin when placing ice machine on bin.

Control Panel Bezel

The ice machine ships with two bezels:

- The standard bezel allows the display screen to be viewed and the menu, arrows and check mark buttons can be accessed.
- The key guard bezel allows the display screen to be viewed and covers all buttons to prevent unauthorized settings from being entered. The ice machine door must be opened to access the control panel.

To change the bezel, open the ice machine door, remove the two screws securing the bezel and slide the bezel to the right while lifting forward.

An optional cover that completely hides the display is a sales kit, and is available through your local distributor or service company.

Top Air Discharge Kit

The top air discharge kit can be used on select ice machine models. This kit directs warm exhaust air upward rather than out the side panels.

LuminIce® II

The LuminIce® growth inhibitor recirculates the air in the ice machine foodzone over a UV bulb. This process will inhibit the growth of common micro-organisms on all exposed foodzone surfaces.

- LuminIce® bulbs require replacement on a yearly basis.
- The control board can be set to automatically display a reminder after 12 months.
- A remote light is available for reminder indication.

NOTE: LuminIce® and LuminIce® II bulbs are not interchangeable; verify your model before ordering a replacement bulb.

Cleanup Procedure for Accidental Bulb Breakage

The cleanup procedure is identical to the procedure used to clean up compact fluorescent (CFL) or fluorescent tube lights. These lights contain a small amount of mercury sealed within a glass tube. Breaking these types of lights will release mercury and mercury vapor. The broken bulb can continue to release mercury vapor until it is cleaned up and removed.

The latest EPA procedures can be viewed on their website at www.epa.gov/cfl/cflcleanup.html.

How To Read A Model Number

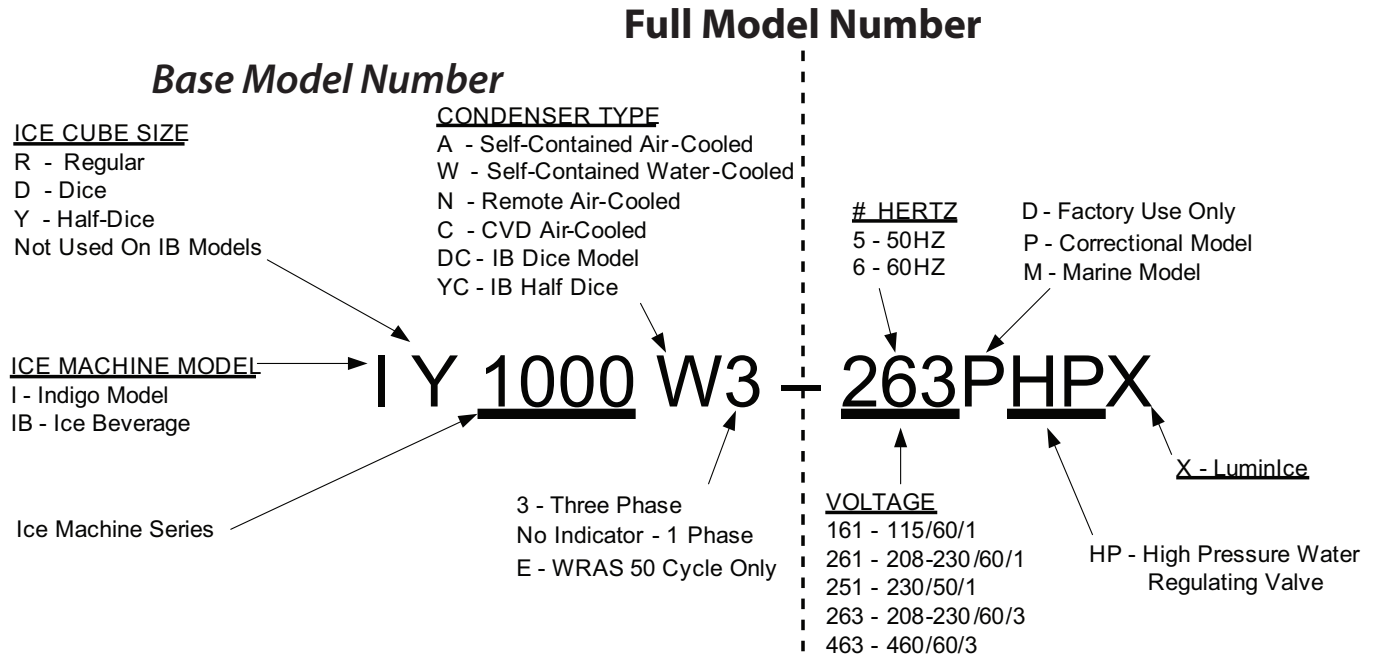

NOTE: These products are hermetically sealed and contain fluorinated greenhouse gas R404A.



Section 2 Installation

Installation

Location Requirements

The location selected for the ice machine head section must meet the following criteria. If any of these criteria are not met, select another location.

- The location must be indoors and must be free of airborne and other contaminants.
- The location must not be near heat-generating equipment or in direct sunlight.
- The location must allow enough clearance for water, drain, and electrical connections in the **rear of the ice machine**.
- The location must not obstruct airflow through or around the ice machine.

Installation Requirements

- The ice machine and bin must be level.
- Vent the ice machine and bin drains separately.
- Bin drain termination must have an air gap.
- The ice machine and bin must be sanitized after installation.
- The drain line must contain a union or other suitable means of disconnection at the ice machine.

QuietQube Models Only

- The ice machine top panel can be trimmed with an aviator snips to allow the line set, water line and electrical connections to exit the top. Only cut out what is needed, the back panel must support the top panel.
- The water inlet and electrical connection must contain a service loop to allow future access.

Minimum/Maximum Temperatures

Model	Minimum Air Temperature	Maximum Air Temperature
All Ice Machine Head Sections	2°C 35°F	43°C 110°F

All Remote Condensers	-29°C -20°F	49°C 120°F
-----------------------	----------------	---------------

QuietQube Condensing Units		
ICVD0695 - ICVD0696 ICVD1195 - ICVD1196 ICVD2095 - ICVD2196	-29°C -20°F	49°C 120°F
ICVD0895 - ICVD0896 ICVD0996 ICVD1095 - ICVD1096 ICVD1495 - ICVD1496 ICVD1895 - ICVD1896	-29°C -20°F	54°C 130°F

Ice Machine Heat of Rejection

Ice Machine Series	Heat of Rejection	
	Air Conditioning	Peak
I0300	4600	5450
I0320	3800	6000
I0450	5400	6300
I0500	6100	6900
I0520	5400	6300
I0600	9000	13900
I0850	13000	16000
I0906	13000	16000
I1000	16250	18600
I1200	20700	24500
I1400	23500	27000
I1800	31000	36000
I3300	45000	51000

Use this information when:

- Sizing air conditioning equipment where self-contained air-cooled ice machines are installed.
- Determining the load on a cooling tower – Use the peak figure for sizing the load.



Clearance Requirements

I0300	Self-Contained Air-Cooled	Self-Contained Water-Cooled
Top/Sides	40 cm (16")	20 cm (8")
Back	13 cm (5")	13 cm (5")

I0450/I0500/ I0600/ I0850/I0900/I1000/ I1100	Self-Contained Air-Cooled	Water-Cooled or Remote Condenser
Top/Sides	20 cm (8")	20 cm (8")
Back	13 cm (5")	13 cm (5")

I0320/I0520	Self-Contained Air-Cooled	Self-Contained Water-Cooled
Top/Sides	31 cm (12")	20 cm (8")
Back	13 cm (5")	13 cm (5")

I0500 230/50/1 Tropical Rating	Self-Contained Air-Cooled	N/A
Top	61 cm (24")	
Sides/Back	31 cm (12")	

I1200	Self-Contained Air-Cooled	Water-Cooled or Remote Condenser
Top	20 cm (8")	20 cm (8")
Sides	31 cm (12")	20 cm (8")
Back	13 cm (5")	13 cm (5")

I1400/I1800	Self-Contained Air-Cooled	Water-Cooled or Remote Condenser
Top/Sides	61 cm (24")	20 cm (8")
Back	31 cm (12")	13 cm (5")

I3300	Self-Contained Water-Cooled	N/A
Top/Sides	20 cm (8")	
Back	61 cm (24")	

NOTE: Top air discharge kits require the same clearance requirements as the comparable self-contained air-cooled model.

QuietQube Model Clearance Requirements

Model	Top	Back	Sides
I0600C - I0686C I0870C - I0876C I0976C I1070C - I1076C I1176C I1470C - I1476C I1870C - I1876C I2170C - I2176C	13 cm (5")	13 cm (5")	13 cm (5")
IB0690C - IB0890C - IB0896 IB1090C - IB1096	5 cm** (2")	13 cm (5")	20 cm** (8")

** 61 cm (24") is recommended on top/sides for servicing

Condensing Unit Clearance Requirements

Model	Top/Sides	Back	Front
ICVD0695 - ICVD0696 ICVD0895 - ICVD0896 ICVD0996 ICVD1095 - ICVD1096 ICVD1195 - ICVD1196 ICVD1495 - ICVD1496 ICVD1895 - ICVD1896 ICVD2095 - ICVD2096	0 cm* (0")	122 cm (48")	122 cm (48")

* 61 cm (24") is recommended on top/sides for servicing

⚠ Caution

The ice machine must be protected if it will be subjected to temperatures below 0°C (32°F). Failure caused by exposure to freezing temperatures is not covered by the warranty.



Bin Installation

NOTE: When using casters, the units must be tethered or secured to comply with all applicable codes. Swivel casters must be mounted on the front and rigid casters must be mounted on the rear. Lock the front casters after installation is complete.

1. Remove threaded plug from drain fitting.
2. Screw the leveling legs onto the bottom of the bin.
3. Screw the foot of each leg in as far as possible.
4. Move the bin into its final position.
5. Level the bin to assure that the bin door closes and seals properly. Use a level on top of the bin. Turn the base of each foot as necessary to level the bin.
6. Inspect bin gasket prior to ice machine installation. (Manitowoc bins come with a closed cell foam gasket installed along the top surface of the bin.)
7. Remove all panels from ice machine before lifting and installing on bin. Remove both front panels, top cover, left and right side panels.

Air Baffle

Self-Contained Air-cooled Only

The air-cooled baffle prevents condenser air from recirculating. To install:

1. Loosen the back panel screws next to the condenser.
2. Align the keyhole slots in the air baffle with the screw holes and slide the baffle down to lock in place.

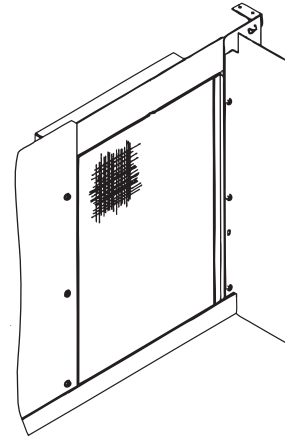

Electrical Requirements

All electrical work, including wire routing and grounding, must conform to local, state and national electrical codes. The following precautions must be observed:

- The ice machine must be grounded.
- A separate fuse/circuit breaker (dedicated circuit) must be provided for each ice machine head section, condenser or condensing unit.
- A qualified electrician must determine proper wire size dependent upon location, materials used and length of run (minimum circuit ampacity can be used to help select the wire size).

Warning

All wiring must conform to local, state and national codes.

Voltage

The maximum allowable voltage variation is +10% / -5% of the rated voltage at ice machine start-up (when the electrical load is highest).

Warning

The ice machine must be grounded in accordance with national and local electrical codes.

Fuse/Circuit Breaker

A separate electrical disconnect, which disconnects all poles and has 3 mm (3/16") contact separation, must be provided for fixed wiring. Circuit breakers must be H.A.C.R. rated in USA.

Minimum Circuit Ampacity

The minimum circuit ampacity is used to help select the wire size of the electrical supply. (Minimum circuit ampacity is not the ice machine's running amp load.)

The wire size (or gauge) also depends on location, materials used, length of run, etc., so it must be determined by a qualified electrician.

Ground Fault Circuit Interrupter

We do not recommend the use of a GFCI/GFI circuit protection with our equipment. If a GFCI/GFI is required by code, use a GFCI/GFI breaker rather than an outlet, which is more prone to intermittent nuisance trips than panel circuit breakers.

Important

3-Phase Scroll Compressors Only - Verify the direction of rotation is correct on the 3-phase scroll compressor. The ice machine will have high suction pressure, low discharge pressure and will be noticeably loud. Reverse any two incoming power leads to reverse rotation.

Maximum Breaker Size & Minimum Circuit Amperage Chart

NOTE: Due to continuous product improvements, this information is for reference only. Please refer to the ice machine data plate to verify electrical data. Data plate information overrides information listed on this page.

Ice Machine	Voltage/Phase/ Cycle	Air-Cooled		Water-Cooled		Remote	
		Maximum Fuse/Circuit Breaker	Minimum Circuit Amps	Maximum Fuse/Circuit Breaker	Minimum Circuit Amps	Maximum Fuse/Circuit Breaker	Minimum Circuit Amps
10300	115/1/60	15	10.8	15	10.0	N/A	N/A
	230/1/50	15	6.1	15	5.6	N/A	N/A
	230/1/60	15	6.1	15	5.7	N/A	N/A
10320	115/1/60	15	11.5	15	10.7	N/A	N/A
	208-230/1/60	15	6.0	15	5.6	N/A	N/A
	230/1/50	15	6.0	15	5.6	N/A	N/A
10450	115/1/60	20	13.2	20	12.5	N/A	N/A
	208-230/1/60	15	6.6	15	6.2	N/A	N/A
	230/1/50	15	7.1	15	6.8	N/A	N/A
10500	115/1/60	20	14.2	20	13.5	25	20.0
	208-230/1/60	15	6.1	15	5.7	N/A	N/A
	230/1/50	15	7.1	15	6.8	15	6.7
10520	115/1/60	20	14.4	20	13.5	N/A	N/A
	208-230/1/60	15	6.1	15	5.7	N/A	N/A
	230/1/50	15	7.1	15	6.8	N/A	N/A
10600	208-230/1/60	15	10.2	15	9.7	15	10.7
	230/1/50	15	6.7	15	6.1	15	7.1
10606	208-230/1/60	15	11.1	15	10.7	15	11.7
	230/1/50	15	6.7	15	6.1	15	7.1
10850	208-230/1/60	20	11.9	20	10.9	20	11.9
	208-230/3/60	15	9.2	15	8.2	15	9.2
	230/1/50	20	10.8	20	9.4	15	10.4
10906	208-230/1/60	20	12.2	20	11.2	20	12.2
	208-230/3/60	15	9.7	15	8.7	15	9.7
	230/1/50	20	12.2	20	11.2	15	12.2
11000	208-230/1/60	20	13.5	15	9.7	15	10.7
	208-230/3/60	15	9.5	15	8.5	15	9.5
	230/1/50	20	13.7	20	12.3	20	12.3
	380-460/3/50-60	N/A	N/A	15	4.5	N/A	N/A
11100	208-230/1/60	20	13.5	15	9.7	15	10.7
	208-230/3/60	15	9.5	15	8.5	15	9.5
	230/1/50	20	13.7	20	12.3	20	12.3
	380-460/3/50-60	N/A	N/A	15	4.5	N/A	N/A
11106	208-230/1/60	20	13.0	15	11.9	15	12.9
	208-230/3/60	15	9.8	15	8.7	15	9.7
	230/1/50	15	9.0	15	8.7	15	9.7
11200	208-230/1/60	25	25.0	25	25.0	N/A	N/A
	208-230/3/60	20	16.0	20	16.0	N/A	N/A
	230/1/50	20	13.7	20	12.3	N/A	N/A
11400	208-230/1/60	30	18.3	30	16.9	30	17.9
	208-230/3/60	20	13.2	20	11.8	20	12.8
	230/1/50	30	15.9	30	15.9	30	16.9
	380-460/3/50-60	N/A	N/A	15	6.4	N/A	N/A
11406	208-230/1/60	30	15.9	30	14.3	30	14.9
	208-230/3/60	20	12.3	20	11.3	20	12.3
	230/1/50	30	15.8	30	14.2	30	16.9
	380-460/3/50-60	N/A	N/A	15	6.4	N/A	N/A
11800	208-230/1/60	40	23.8	40	22.4	40	23.4
	208-230/3/60	25	15.4	25	14.0	25	15.0
	230/1/50	30	18.3	30	16.9	40	17.9
	380-460/3/50-60	N/A	N/A	15	6.5	N/A	N/A
11806	208-230/1/60	40	23.8	40	22.4	40	23.4
	208-230/3/60	25	15.4	25	14.0	25	15.0
	230/1/50	30	18.3	30	16.9	30	17.9
	380-460/3/50-60	N/A	N/A	15	6.5	N/A	N/A

QuietQube Head Sections

Ice Machine	Voltage/Phase/Cycle	Maximum Fuse/Circuit Breaker	Minimum Circuit Amps	Total Amps
Ice Beverage Models	115/1/60	15 amp	N/A	1.1
	230/1/60	15 amp	N/A	1.5
All Non IB QuietQube Models	115/1/60	15 amp	1.1	N/A
	208-230/1/60	15 amp	1.1	N/A
	230/1/50	15 amp	1.5	N/A

ICVD Condensing Units

Condensing Unit	Voltage/Phase/Cycle	Maximum Fuse/Circuit Breaker	Minimum Circuit Amps	Minimum Wire Size Required by Manitowoc
ICVD0695	208-230/1/60	15 amp	11.0	#12 Solid Copper Conductor
	208-230/3/60	15 amp	7.5	#12 Solid Copper Conductor
	230/1/50	15 amp	11.0	#12 Solid Copper Conductor
ICVD0696	208-230/1/60	15 amp	11.6	#12 Solid Copper Conductor
	208-230/3/60	15 amp	10.2	#12 Solid Copper Conductor
	230/1/50	15 amp	10.2	#12 Solid Copper Conductor
ICVD0895	208-230/1/60	20 amp	11.8	#10 Solid Copper Conductor
	208-230/3/60	15 amp	9.1	#12 Solid Copper Conductor
	230/1/50	20 amp	11.8	#10 Solid Copper Conductor
ICVD0896	208-230/1/60	20 amp	11.8	#10 Solid Copper Conductor
	208-230/3/60	15 amp	9.1	#12 Solid Copper Conductor
	230/1/50	20 amp	11.8	#10 Solid Copper Conductor
ICVD0996	208-230/1/60	20 amp	12.5	#10 Solid Copper Conductor
	208-230/3/60	15 amp	9.5	#12 Solid Copper Conductor
	230/1/50	20 amp	12.5	#10 Solid Copper Conductor
ICVD1095	208-230/1/60	20 amp	15.0	#10 Solid Copper Conductor
	208-230/3/60	15 amp	15.0	#12 Solid Copper Conductor
	230/1/50	20 amp	15.0	#10 Solid Copper Conductor
ICVD1195	208-230/1/60	25 amp	14.2	#8 Solid Copper Conductor
	208-230/3/60	15 amp	9.5	#10 Solid Copper Conductor
	230/1/50	35 amp	14.7	#8 Solid Copper Conductor
ICVD1195 Bristol Compressor	208-230/1/60	25 amp	14.5	#8 Solid Copper Conductor
	208-230/3/60	15 amp	9.3	#10 Solid Copper Conductor
	230/1/50	35 amp	14.3	#8 Solid Copper Conductor
ICVD1495	208-230/1/60	20 amp	20.0	#10 Solid Copper Conductor
	208-230/3/60	15 amp	15.0	#12 Solid Copper Conductor
	230/1/50	20amp	20.0	#8 Solid Copper Conductor
ICVD1496	208-230/1/60	20 amp	11.7	#10 Solid Copper Conductor
	208-230/3/60	15 amp	8.9	#12 Solid Copper Conductor
	230/1/50	20 amp	11.7*	#8 Solid Copper Conductor
ICVD1895	208-230/1/60	40 amp	25.0	#8 Solid Copper Conductor
	208-230/3/60	25 amp	20.0	#10 Solid Copper Conductor
	230/1/50	40 amp	25.0	#8 Solid Copper Conductor
ICVD2095 / ICVD2096	208-230/1/60	50 amp	40.0	#6 Solid Copper Conductor
	208-230/3/60	30 amp	30.0	#10 Solid Copper Conductor

ICVD2095 & ICVD2096 Only - Verify the direction of the rotation is correct on the 3-phase scroll compressor. The ice machine will have high suction pressure, low discharge pressure and will be noticeably loud. Reverse two incoming power leads to reverse rotation.

ICVD Interconnecting Wiring

Indigo QuietQube ice machines require interconnecting low voltage wiring (included with Manitowoc line sets) to energize the contactor coil and verify the LPCO & HPCO are closed. This circuit also initiates a time delay whenever the LPCO or HPCO open. Failure to properly wire the ICVD condensing unit or ice machine head section will result in a non-operational machine. Refer to the Indigo Technicians Handbook for normal operation and diagnostics for the HPCO & LPCO controls.

Connections on an RDI condensing unit are identical to the ICVD connections.

Wire Specifications:

- 18 AWG - 5 Conductor, Single Strand
- Plenum Rated
- UL rated to 300 Volts

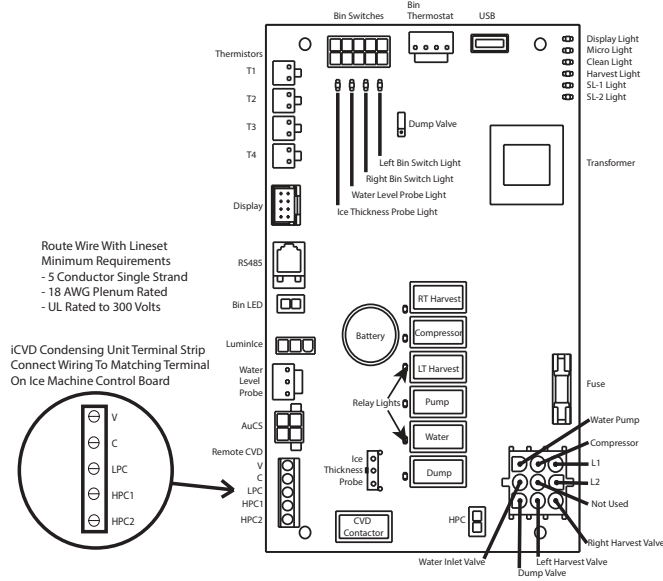

ICVD Transformer Wiring

ICVD condensing units leave the factory with the L2 voltage leads for the transformer disconnected. Failure to connect the transformer leads will result in a non-operable condensing unit. Failure to correctly wire the transformer will result in premature transformer failure.

1. Measure voltage with a voltmeter
2. Wire transformer to match voltage range
3. Cap unused lead to prevent shorting to ground.

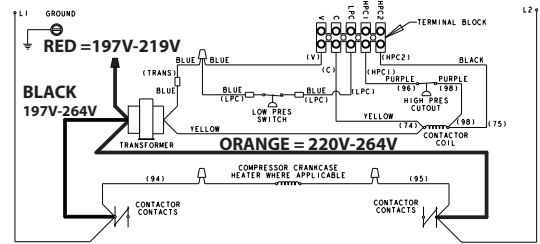

Remote Condenser Wiring

Interconnecting line voltage wiring is used to energize and de-energize the condenser fan motor.

The remote condenser voltage matches the ice machine head section voltage.

Interconnecting Wire Connections	
Ice Machine Head Section	Remote Condenser
F1	L1
F2	L2



Water Supply and Drain Line Sizing/Connections

⚠ Caution

Do not apply heat to water inlet valve or water drain fittings. Heating will damage the nonmetallic connector. Do not over tighten fittings. Two turns after hand tight is the maximum.

- Local water conditions may require treatment of the water to inhibit scale formation, filter sediment, and remove chlorine odor and taste.
- Connect ice making water inlet to potable water only.
- Do not connect to hot water supply.
- Install a water shut-off valve.
- Insulate water and drain lines to prevent condensation.

Location	Water Temperature	Water Pressure	Ice Machine Fitting	Tubing Size up to Ice Machine Fitting
Ice Making Water Inlet	4,4°C (40°F) Min. 32°C (90°F) Max.	140 kPa (20 psi) Min. 550 kPa (80 psi) Max.	3/8" Female Pipe Thread	10 mm (3/8") minimum inside diameter
Ice Making Water Drain	—	—	1/2" Female Pipe Thread	13 mm (1/2") minimum inside diameter
Condenser Water Inlet	4,4°C (40°F) Min. 32°C (90°F) Max.	140 kPa (20 psi) Min. 1030 kPa (150 psi) Max.	I0300 - I1000 = 3/8" Female Pipe Thread I1106 - I1800 = 1/2" Female Pipe Thread	
Condenser Water Drain	—	—	1/2" Female Pipe Thread	13 mm (1/2") minimum inside diameter
Bin Drain	—	—	3/4" Female Pipe Thread	19 mm (3/4") minimum inside diameter
Large Capacity Bin Drain			1" Female Pipe Thread	25 mm (1") minimum inside diameter

Min. = Minimum, Max. = Maximum

Air Gap

A greater than 1-inch air gap is built into the ice machine for back-flow prevention. This air gap exceeds NSF 12 requirements for back-flow prevention.

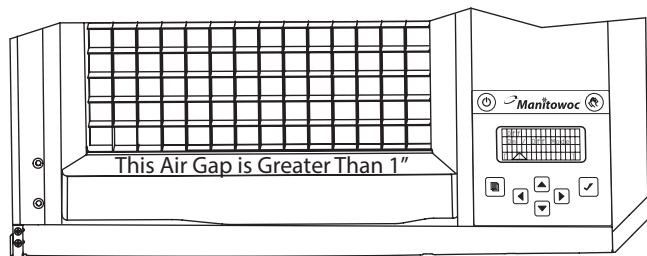

Cooling Tower Applications (Water-Cooled Models)

A water cooling tower installation does not require modification of the ice machine.

- Water pressure at the condenser cannot exceed 1034 kPa (150 psig). A special order unit is available that allows water pressure up to 2413 kPa (350 psig).
- Water entering the condenser must not exceed 32°C (90°F).
- Water flow through the condenser must not exceed 19 liters (5 gallons) per minute.
- Allow for a pressure drop of 50 kPa (7 psi) between the condenser water inlet and the outlet of the ice machine.
- Water exiting the condenser must not exceed 43°C (110°F).



Drain Connections

Follow these guidelines when installing drain lines to prevent drain water from flowing back into the ice machine and storage bin:

- Drain lines must have a of run 2.5 cm per meter (1.5 inch drop per 5 feet) and must not create traps.
- The floor drain must be large enough to accommodate drainage from all drains.
- Run separate bin and ice machine drain lines. Insulate them to prevent condensation.
- Vent the ice machine drain to the atmosphere.
- Drain termination must have an air gap that meets local code.

Auxiliary Base Drain Installation

Two types of auxiliary drain are located in the ice machine base to remove moisture in high humidity areas: With or without a drain socket.

ICE MACHINES WITH AN AUXILIARY DRAIN SOCKET

1. Remove membrane in socket with a dowel or screwdriver and proceed to step 3.

ICE MACHINES WITHOUT AN AUXILIARY DRAIN SOCKET

1. View the back of the ice machine base on the compressor side, and locate the dimple.
2. Drill a 16 mm (5/8") hole using the dimple as a guide.

NOTE: Do not use a drill larger than 16 mm (5/8") or irreparable damage will occur.

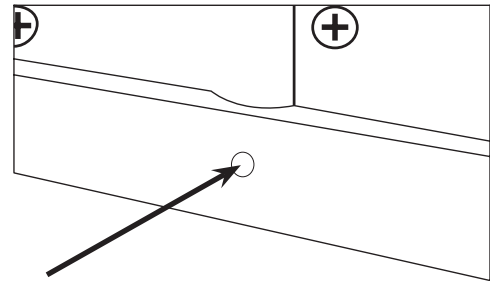

3. Route tubing to an open site drain:
 - Use 1/2 inch CPVC tubing.
 - Provide support for tubing.
 - Apply a bead of silicone around the exterior of the ice machine tubing and insert into ice machine base. The silicone will secure the tubing and provide a watertight seal.

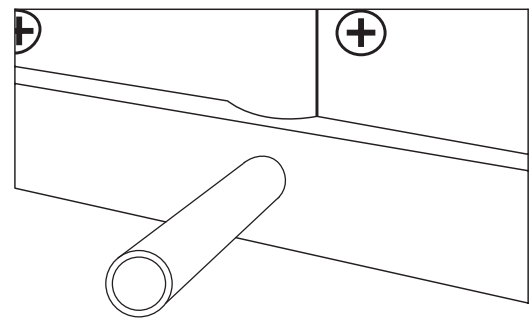

Remote Condenser and Remote Condensing Unit Refrigeration System Installation

Each ice machine head section ships from the factory with a refrigerant charge appropriate for the entire system operation. The serial tag on the ice machine indicates the refrigerant charge.

QuietQube Models

QuietQube® Ice Machine	Remote Single Circuit Condenser	Line Set*	Additional Refrigerant Charge for 15 to 30 Meter Line Sets (50' - 100')
I0680C IB690C	ICVD0695	RC-26 RC-36 RC-56	680 g - 1.5 lbs
IB0686C IB0696C	ICVD0696		680 g - 1.5 lbs
I0870C IB0890C	ICVD0895		1814 g - 4 lbs 907 g - 2 lbs
IB0890C I0976C	ICVD0996		907 g - 2 lbs
I1070C	ICVD1095		907 g - 2 lbs
IB1090C	ICVD1195		907 g - 2 lbs
I1176C	ICVD1195		907 g - 2 lbs
I1470C	ICVD1495		907 g - 2 lbs
I1476C	ICVD1495		907 g - 2 lbs
I1870C	ICVD1895		RC-55
I2170C	ICVD2095	RC-28	1814 g - 4 lbs
I2176C	ICVD2096	RC-38 RC-58	1814 g - 4 lbs
I3070C	ICVD3095	RC-29/39/59	1361 g - 3 lbs

*Line Set	Suction Line	Liquid Line	Minimum Insulation Thickness
RC 26/36/56	16 mm 5/8 inch	10 mm 3/8 inch	13 mm (1/2") Suction Line 7 mm (1/4") Liquid Line
RC 25/35/55	19 mm 3/4 inch	13 mm 1/2 inch	13 mm (1/2") Suction Line 7 mm (1/4") Liquid Line
RC 28/38/58	19 mm 3/4 inch	16 mm 5/8 inch	13 mm (1/2") Suction Line 7 mm (1/4") Liquid Line
RC 29/39/59	Two Lines 19 mm 3/4 inch	One Line 16 mm 5/8 inch	19 mm (3/4") Suction Line 7 mm (1/4") Liquid Line

⚠ Warning

Installation of a QuietQube® Condensing Unit may require the use of special equipment for placement. Trained and qualified personnel are required for proper rigging and lifting. Holes are provided on the corners of the condensing unit to allow the use of lifting shackles.

Important

Manitowoc remote systems are only approved and warranted as a complete new package. Warranty on the refrigeration system will be void if a new ice machine head section is connected to pre-existing (used) tubing or condensing units or vice versa.

Remote Condenser Models

Remote Condenser Ice Machine	Remote Condenser	Additional Amount of Refrigerant to Be Added to Nameplate Charge for 15 to 30 Meter Line Sets (50'-100')
I0590N	JC0495	680 g - 1.5 lbs
I0690N	JC0895	680 g - 1.5 lbs
I0890N	JC0895	907 g - 2 lbs
I0996N	JC0995	907 g - 2 lbs
I1090N I1196N	JC0995	907 g - 2 lbs
I1490N	JC1395	907 g - 2 lbs
I1890N	JC1395	907 g - 2 lbs

Line Set	Discharge Line	Liquid Line	Model
RT 20/35/50	12.7 mm 1/2 inch	7.9 mm 5/16 inch	I0590/I0690 I0890/I0996/ I1090/I1196
RL 20/35/50	12.7 mm 1/2 inch	9.5 mm 3/8 inch	I1490/I1890

⚠ Warning

Potential Personal Injury Situation

The ice machine head section contains the refrigerant charge. Installation and brazing of the line sets must be performed by a properly trained and EPA certified refrigeration technician aware of the dangers of dealing with refrigerant charged equipment.



CALCULATING REMOTE CONDENSER & REMOTE CONDENSING UNIT INSTALLATION DISTANCES

Line Set Length

The maximum tubing length is 30 meters (100 feet).

Line Set Rise/Drop

The maximum rise is 10.7 meters (35 feet).

The maximum drop is 4.5 meters (15 feet).

⚠ Caution

If a line set has a rise followed by a drop, another rise cannot be made. Likewise, if a line set has a drop followed by a rise, another drop cannot be made.

1. Insert the **measured rise** into the formula below. Multiply by 1.7 to get the **calculated rise**.
2. Insert the **measured drop** into the formula below. Multiply by 6.6 to get the **calculated drop**.
3. Insert the **measured horizontal distance** into the formula below. No calculation is necessary.
4. Add together the **calculated rise, calculated drop, and horizontal distance** to get the **total calculated distance**. If this total exceeds 45 meters (150 feet), move the condenser/condensing unit to a new location and perform the calculations again.

Calculated Line Set Distance

The maximum calculated distance is 45 meters (150 feet).

Line set rises, drops, horizontal runs (or combinations of these) in excess of the stated maximums will exceed compressor start-up and design limits. This will cause poor oil return to the compressor. Make the following calculations to make sure the line set layout is within specifications.

Maximum Line Set Distance Formula

- Step 1. Measured Rise (R) 10.7 meters (35 feet) Maximum _____ x 1.7 = _____ Calculated Rise
- Step 2. Measured Drop (D) 4.5 meters (15 feet) Maximum _____ x 6.6 = _____ Calculated Drop
- Step 3. Measured Horizontal Distance (H) 30 meters (100 feet) Maximum _____ Horizontal Distance
- Step 4. Total Calculated Distance 45 meters (150 feet) Maximum _____ Total Calculated Distance

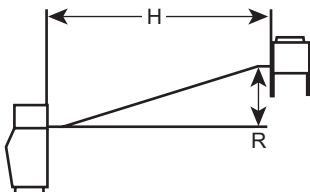

SV1196

Combination of a Rise and a Horizontal Run

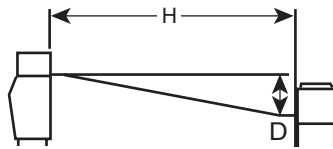

SV1195

Combination of a Drop and a Horizontal Run

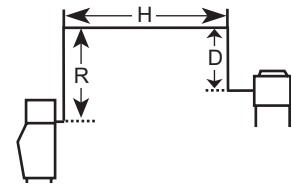

SV1194

Combination of a Rise, a Drop and a Horizontal Run



⚠ Caution

The refrigeration system warranty will not apply if the Manitowoc Ice Machine and Manitowoc ICVD Condensing Unit are not installed according to specifications. This warranty also will not apply if the refrigeration system is modified with a condenser, heat reclaim device, or other parts or assemblies not manufactured by Manitowoc.

Step 1 Secure the Condenser.

Through-holes are provided to secure the condenser to a curb, rack or wooden timber.

⚠ Warning

The ice machine head section contains refrigerant charge. The ice machine head section contains refrigeration valves that must remain closed until proper installation of the line sets is completed.

⚠ Warning

Electrical power to the ice machine head section, condensing unit or condenser must be disconnected before proceeding.

Step 2 Route the Refrigeration Tubing.

Route the refrigeration tubing between the ice machine head section and the condenser or ICVD® condensing unit.

- Maximum lineset exposed on rooftop is 25% of total line set length.
- A qualified person must perform all roof penetrations.

QuietQube Models Only

- A suction line oil trap is required when rise is more than 6 meters (20 feet).
- Only one trap is allowed in the lineset.
- Shorten the lineset as required, do not coil lineset.

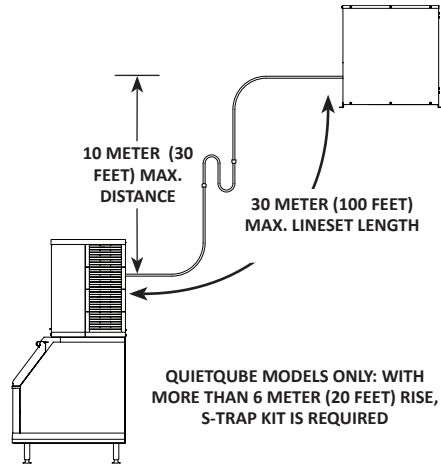

Manitowoc S-Trap Kit

Model	S-Trap Kit Number	Tubing Size
I0680C I0686C I0690C I0686C I0696C I0870C I0876C I0890C I0976C I1070C I1076C I1090C I1096C I1176C	K00172	16 mm (5/8 inch)
I1470C I1476C I1870C I1876C I2170C I2176C	K00166	19 mm (3/4 inch)



Step 3 Connect the Line Set.

Remote Condensers Only

In most cases, by routing the line set properly, shortening will not be necessary. When shortening or lengthening is required, do so before connecting the line set to the ice machine or the remote condenser. This prevents the loss of refrigerant in the ice machine or condenser.

The quick connect fittings on the line sets are equipped with access valves. Use these valves to recover any vapor charge from the line set. When lengthening or shortening lines, follow good refrigeration practices, purge with nitrogen and insulate all tubing. Do not change the tube sizes. Evacuate the lines and place about 145 grams (5 oz) of vapor refrigerant charge in each line.

1. Remove the dust caps from the line set, condenser and ice machine.
2. Apply refrigeration oil to the threads on the quick-disconnect couplers before connecting them to the condenser.
3. Carefully thread the female fitting to the condenser or ice machine by hand, then tighten the couplings with a wrench until they bottom out.
4. Turn an additional quarter turn to ensure proper brass-to-brass seating. Torque to the following specifications:

Liquid Line	Discharge Line
13.5-16.2 N•m	47.5-61.0 N•m

5. Check all fittings and valve caps for leaks and reinstall and tighten caps.
6. The receiver service valve is closed during shipment and must be opened before starting the ice machine.
 - A. Remove the receiver service valve cap.
 - B. Backseat (open) the valve.
 - C. Reinstall the cap and panels.
7. Interconnecting line voltage wiring is used to energize and de-energize the condenser fan motor. The remote condenser voltage matches the ice machine head section voltage.

Interconnecting Wire Connections	
Ice Machine Head Section	Remote Condenser
F1	L1
F2	L2

Installation is finished for remote condenser models. Proceed to page 25 for start-up procedure.

QuietQube Models Only

- Maximum amount of time the refrigeration system can be exposed to the atmosphere is 15 minutes.
- Purge line set with dry nitrogen while brazing.
- Shutoff valves for the line set on the ice machine must remain closed and be protected from heat during brazing.
- The condensing unit ships with a 50/50 mixture of nitrogen/helium.

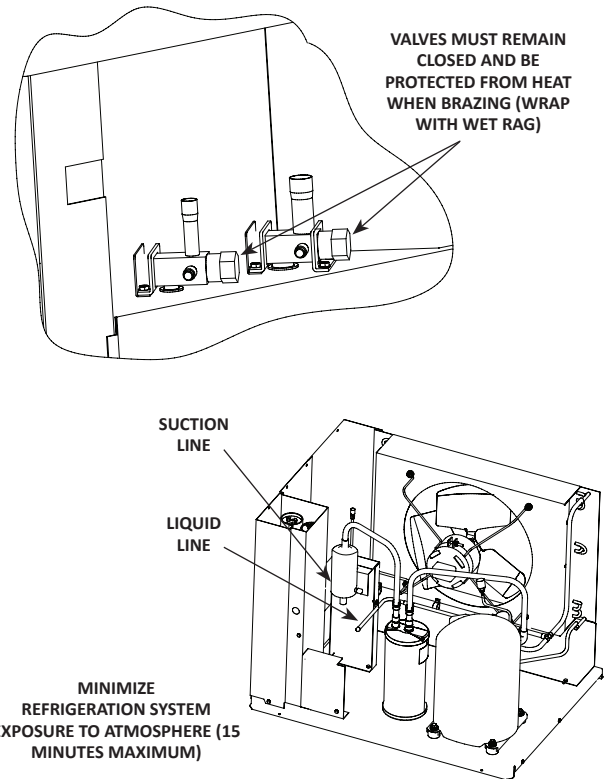

Step 4 Pressure Test and Evacuate Line Set and ICVD Condensing Unit.

- Shutoff valves for the line set must remain closed until pressure testing and evacuation are complete.
- Valve core removal tools that allow for removal and installation of the valve cores without removing hoses for the manifold gauge set are recommended to decrease the evacuation time.
- Pressure test at 1000 kPa (150 psi) for a minimum of 15 minutes.
- Minimum evacuation level is 500 microns.

Pressure test the line sets and ICVD Condensing Unit with 1000 kPa (150 psi) of dry nitrogen. Add nitrogen at the shutoff valves for the line set located at the back of the ice machine head section or from the access valves located in the ICVD Condensing Unit. Complete the pressure test, verify no leaks are present and remove the nitrogen from the system before connecting the vacuum pump.

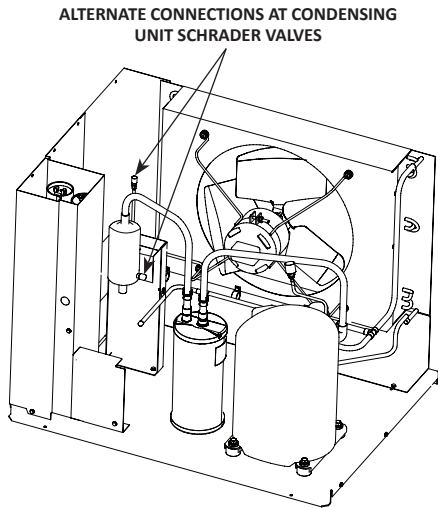

A retention valve is present in the compressor discharge line. The retention valve requires evacuation connections at four points.

Ice Machine Head Section

1. Low side shut off valve on the back of the ice machine
2. High side shut off valve on the back of the ice machine

ICVD Condensing Unit

3. Compressor Discharge Access Valve
4. Suction Filter Access Valve

Connection of a manifold gauge set (or a hose with core depressors on both ends) between the suction-filter access port and the compressor access valve (located between the compressor and discharge line retention valve) is required.

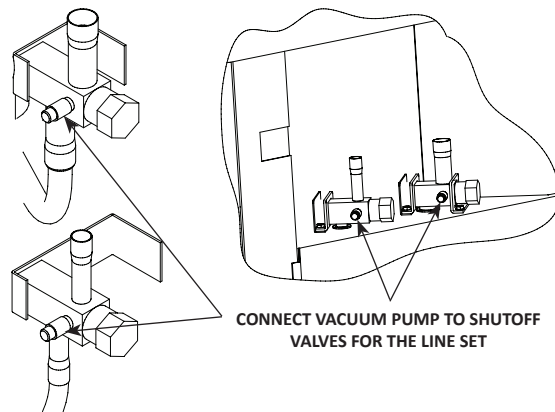
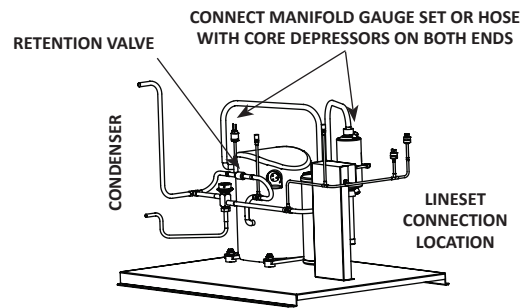

Step 5 Open Valves for the Line Set.

You will not hear refrigerant flow when the valves are opened. Refrigerant will not flow until the ice machine is started and the solenoid valve opens.

- All valve caps must be reinstalled, tightened and leak-checked to assure no refrigerant leakage exists.
- Counterclockwise opens all valves:

Refer to chart and open the shutoff valves for the suction and liquid lines the correct number of 360° turns.

Valve Tubing Size	Number of Turns to Open
3/8"	6
1/2" 5/8" 3/4"	10
7/8"	14

USE ALLEN WRENCH TO OPEN (TURN COUNTERCLOCKWISE) SHUTOFF VALVES FOR THE LIQUID AND SUCTION LINES

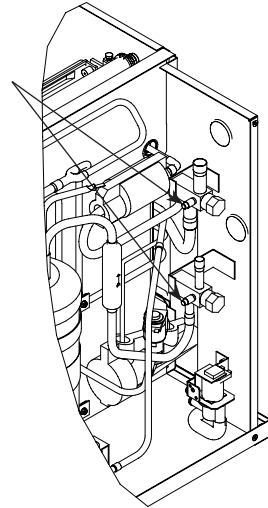

I1470C/I1870C/I2170C

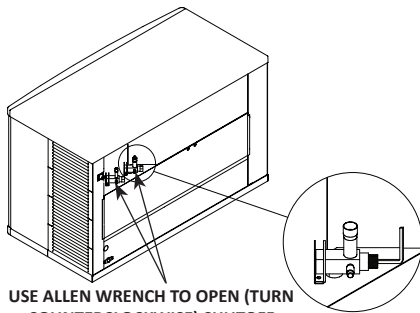

USE ALLEN WRENCH TO OPEN (TURN COUNTERCLOCKWISE) SHUTOFF VALVES FOR THE LIQUID AND SUCTION LINES

QuietQube Models

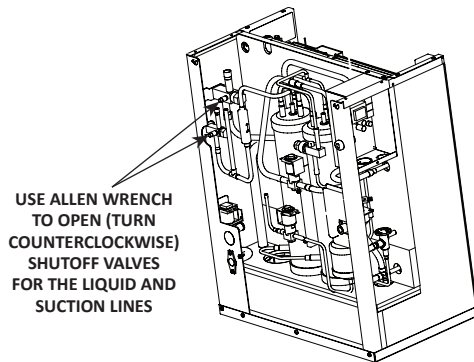

USE ALLEN WRENCH TO OPEN (TURN COUNTERCLOCKWISE) SHUTOFF VALVES FOR THE LIQUID AND SUCTION LINES

Ice Beverage Models

⚠ Caution

After opening suction and discharge valves, refrigerant pressure will not be detected until the ice machine starts a freeze cycle and the solenoid valves energize.



Step 6 Connect Wiring to Condensing Unit or Remote Condenser and Ice Machine Head Section.

ICVD REMOTE CONDENSING UNIT

Attach wiring to terminal strip in control box of condensing unit and control board in ice machine head section. Match wire labels to connections see “ICVD Interconnecting Wiring” on page 15 and “ICVD Transformer Wiring” on page 15.

REMOTE CONDENSER

The remote condenser voltage matches the ice machine head section voltage see “Remote Condenser Wiring” on page 15.

Step 7 Leak-Check the Refrigeration System.

- A. Connect power to the ice machine head section - Do not connect power to the ICVD condensing unit.
- B. Press the power switch and energize the ice machine for 60 seconds to equalize pressures.
- C. Disconnect power to the ice machine head section.
- D. Leak-check lineset connections, S trap and all factory joints in head section and condensing unit.
- E. Connect power to the ICVD condensing unit and allow system to pump down.

Step 8 Insulation Requirements

- To prevent condensation, the entire suction line, including the shutoff valve, must be insulated.
- All insulation must be airtight and sealed at both ends.

The following insulation requirements prevent condensation at 32°C (90° F) ambient temperature and 90% relative humidity. If higher humidity is expected, increase insulation thickness:

Suction Line	Liquid Line	Min. Insulation Thickness
19 mm 3/4 inch	13 mm 1/2 inch	Suction Line - 13 mm (1/2 inch) Liquid Line - 7 mm (1/4 inch)
16 mm 5/8 inch	10 mm 3/8 inch	
19 mm 3/4 inch	16 mm 5/8 inch	Suction Line - 19 mm (3/4 inch) Liquid Line - 7 mm (1/4 inch)

Step 9 Insulation for the Suction Shutoff Valve

The pre-formed insulation for the suction shutoff valve is located in the plastic bag taped to the water curtain.

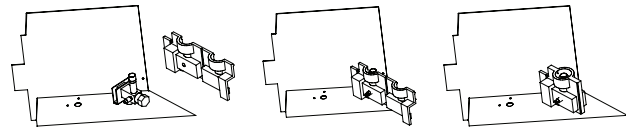

Position Bin Thermostat Probe

Ice Beverage Models Only

The thermostat probe must be moved from the shipping position to the ice-making position.

- The bin thermostat probe must be rotated down to enable ice contact and proper operation.
- Verify probe wire does not interfere with the water curtain.
- The control is preset and does not require programming.
 1. Loosen thumbscrew securing probe.
 2. Rotate the probe from horizontal to vertical position.
 3. Tighten thumbscrew to secure probe.



Starting the Ice Machine

All Manitowoc ice machines are factory-operated and adjusted before shipment. Normally, new installations do not require any adjustment.

Starting the ice machine and completing the Operational Checks are the responsibilities of the owner/operator.

Adjustments and maintenance procedures outlined in this manual are not covered by the warranty.

Set the date and time for your area and verify the control board settings are correct for your location and application.

Warning

Do not operate equipment that has been misused, abused, neglected, damaged, or altered/modified from that of original manufactured specifications.

This appliance is not intended for use by persons (including children) with reduced physical, sensory or mental capabilities, or lack of experience and knowledge, unless they have been given supervision concerning use of the appliance by a person responsible for their safety. Do not allow children to play with, clean or maintain this appliance without proper supervision.

Important

Refrigeration compressors must be operated for a minimum break-in period of 72 hours before full ice production will be reached.

Set the Language, Time and Date

When the ice machine is installed, the correct time and date needs to be set for its location.

1. Ensure that the ice machine's power is on.
2. Press the Menu button.
3. Press the Down arrow until Set-Up is highlighted [bracketed].
4. Press the Checkmark. The Set-Up menu will be displayed and Language will be highlighted [bracketed]. The default language is English.
5. Press the Checkmark. You can choose to view the display in a language other than English by highlighting your choice and pressing the Checkmark. Selecting one language will deselect the others.
6. When the check reflects your preference, use the Down arrow to navigate to Exit and press the Checkmark. The display will return to the Set-Up menu.

7. Use the Down arrow to highlight Time & Date.
8. Press the Checkmark. The date will appear on the first line of the display (Mo/Day/Yr) and the time will appear on the second line (24 Hour). The month will be underlined.

0	7	2	4	1	0														
1	4	:	0	8															
E	x	i	t																>

9. Using the Up or Down arrow, adjust the month, if necessary.
10. When the correct month appears, use the Right arrow to move the underline to the day.
11. Using the Up or Down arrow, adjust the day, if necessary.
12. When the correct day appears, use the Right arrow to move the underline to the year.
13. Using the Up or Down arrow, adjust the year, if necessary.
14. When the correct year appears, press the Checkmark. The underline will move down to the hour.
15. Using the Up or Down arrow, adjust the hour, if necessary.
16. When the correct hour appears, use the Right arrow to move the underline to minutes.
17. Using the Up or Down arrow, adjust the minutes, if necessary.
18. When the correct minutes appear, press the Checkmark twice.

For more details and instructions for changing ice machine settings, see "Set-Up Menu" in Section 3 Operation.

Remove Ice Thickness Probe Shipping Brackets

Remove and discard shipping brackets before starting the ice machine.

Starting the Ice Machine

Step 1 Refer to cleaning **and** sanitizing procedure and sanitize the ice machine and bin before placing in operation.

Step 2 Press the power button to start ice-making.

NOTE: The water curtain/ice damper(s) must be in place on the evaporator before the ice machine will start.

Refer to the sequence of operation in Section 3 for further operational details.

Step 3 Observe a freeze and harvest cycle, then perform an ice thickness check.

MINIMUM/MAXIMUM SLAB WEIGHT

Adjust ice thickness to meet chart specifications.

Model	Minimum Ice Weight Per Cycle lbs Grams	Maximum Ice Weight Per Cycle lbs Grams
i300	2.40 lbs 1089 grams	2.80 lbs 1270 grams
i320 - i450 - i520	3.40 lbs 1542 grams	3.90 lbs 1769 grams
i500 - i680 - i686 i690 - i696	4.60 lbs 2087 grams	5.20 lbs 2359 grams
i600 - i606	4.12 lbs 1869 grams	4.75 lbs 2155 grams
i850 - i870 - i890 - i976	5.75 lbs 2608 grams	6.50 lbs 2948 grams
i906 -i1000 - i1006 - i1070	6.2 lbs 2812 grams	7.2 lbs 3266 grams
i1200	7.50 lbs 3402 grams	8.20 lbs 3719 grams
i1090	7.50 lbs 3402 grams	8.50 lbs 3856 grams
i1400 - i1406	10.25 lbs 4649 grams	11.50 lbs 5216 grams
i1470	12.0 lbs 5443 grams	14.0 lbs 6350 grams
i1800	13.20 lbs 5987 grams	14.80 lbs 6713 grams
i1870 - i2170 - i2176	15.5 lbs 7031 grams	16.75 lbs 7598 grams

Ice Thickness Check

After a harvest cycle, inspect the ice cubes in the ice storage bin. The ice thickness probe is factory-set to maintain the ice bridge thickness at 3 mm (1/8").

NOTE: Make sure the water curtain is in place when performing this check. It prevents water from splashing out of the water trough.

1. Inspect the bridge connecting the cubes. It should be about 3 mm (1/8") thick.
2. If adjustment is necessary, turn the ice thickness probe adjustment screw clockwise to increase bridge thickness, counterclockwise to decrease bridge thickness. Set at 7 mm (9/32") gap between ice thickness probe and evaporator as starting point, then adjust to achieve a 3 mm (1/8") bridge thickness.

NOTE: Turning the adjustment one-third of a turn will change the ice thickness about 1.5 mm (1/16").

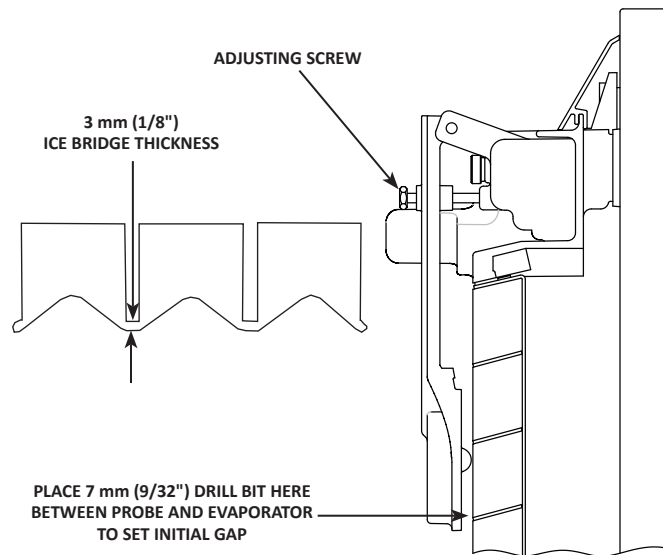

Ice Thickness Check

Make sure the ice thickness probe wire doesn't restrict movement of the probe.



Section 3 Operation

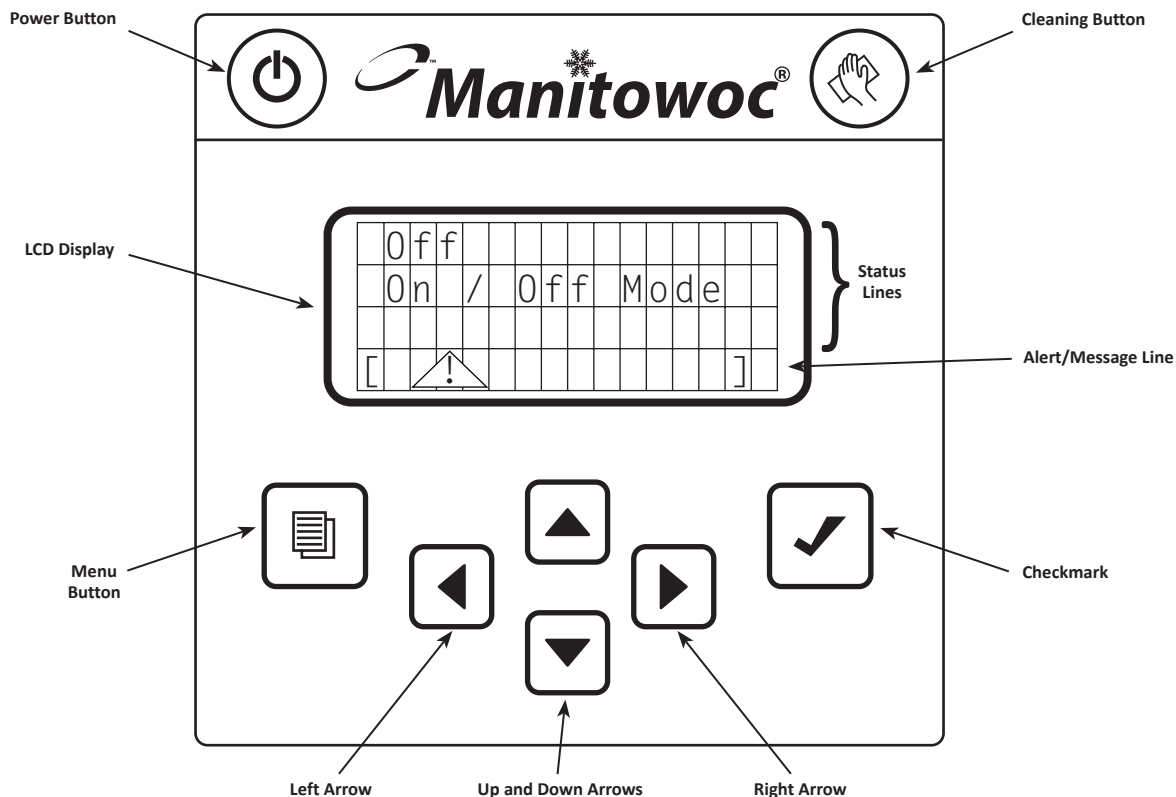

Control Panel Features

The Indigo™ control panel offers a series of pressure-sensitive buttons and a four-line, interactive display panel.

BUTTONS

Power Button: Powers the ice machine when in the On/Off Mode. The ice machine can also be programmed to automatically power on and off in two Energy Saver modes.

Cleaning Button: Initiates a cleaning cycle. Refer to Section 4 for details.

Menu Button: Moves the display from the Home Screen, where ice machine status, alerts and messages are viewed, to the Main Menu, where machine information and its event log can be accessed, machine and Energy Saver settings can be adjusted, and service issues can be addressed.

Left and Right Arrows: The Left arrow moves the display to the previous screen, allowing the user to “back out” of programming. Both the Left and Right arrows will move the cursor (underline) within a line of settings. NOTE: The Right arrow can also be used on many screens interchangeably with the Checkmark to make a selection.

Up and Down Arrows: Move the highlight [brackets] up one line or down one line.

Checkmark: Makes a selection and/or moves to the next screen (or line).

DISPLAY PANEL

The LCD display panel is 16 characters wide and four lines deep. During ice machine operation and cleaning cycles, the Home screen’s top three lines provide valuable status information and the fourth line shows alerts and messages. In programming, four lines of the current menu are displayed and highlights, arrows, cursor and selections inform the user of available actions.

Overview of Menu Navigation

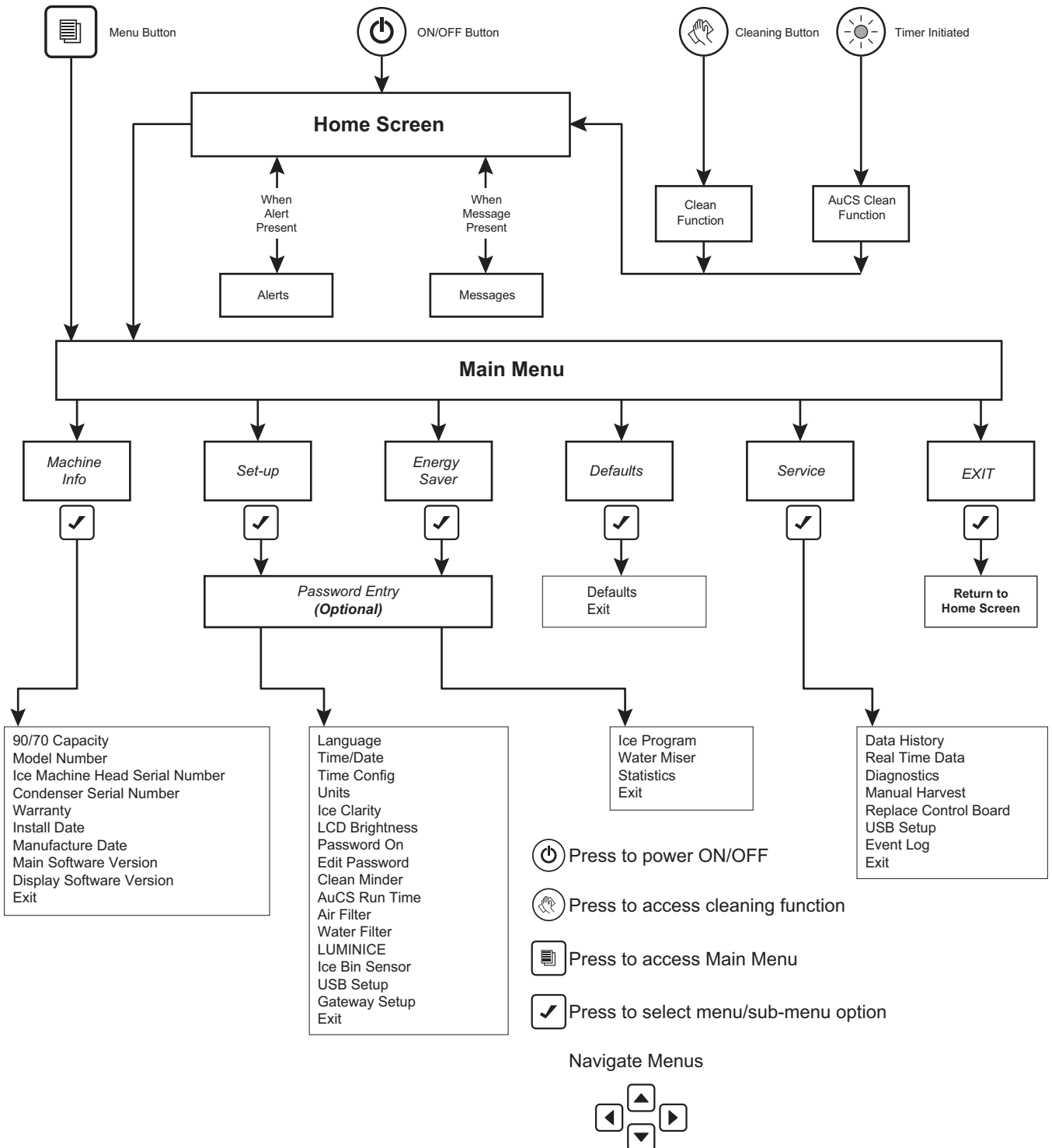

Display Panel Navigation

[T	i	m	e	&	D	a	t	e	>]	▼
	T	i	m	e	C	o	n	f	i	g	>	
	U	n	i	t	s					>		▼

Highlights: Brackets indicate if a line on the screen is “highlighted” or actionable. Move the brackets from line to line using the Down or Up arrow. Move the brackets down from the fourth line to view more of the menu displayed.

Arrows: Two kinds of arrows give cues to additional information. “>” symbols show that another screen is available by pressing the Checkmark while a line is highlighted. “▲” and “▼” symbols indicate the limits of the screen viewed. NOTE: Another cue to the length of a menu screen is that Exit is the last item.

0	7	2	4	1	0							
1	4	:	0	8								
E	x	i	t							>		

Cursor: A cursor (underline) is used within lines where actual settings can be adjusted. In these screens, use the Up and Down arrows to make changes to the value underlined. Move the cursor from digit to digit using the Right and Left arrows. Use the Checkmark to move the cursor down one line. Exit and re-enter the screen to start again at the top.

[M	o	/	D	a	y	/	Y	r	(✓)]	▼
	D	a	y	/	M	o	/	Y	r	()			
	1	2		H	o	u	r			()			
	2	4		H	o	u	r			(✓)		▼

Selections: When parentheses () appear, they indicate a selection is available by pressing the Checkmark while the line is highlighted. If the choice is exclusive, selecting it with the Checkmark will uncheck another selection. That is, in the above Time Config example, selecting Day/Mo/Yr will deselect Mo/Day/Yr.

Alerts and Messages

When messages and alerts exist, they will be highlighted and can be selected with the Checkmark. Alerts are shown on the left side - Alerts are conditions that may cause the ice machine to stop in the near future. Alerts displayed will have priority over messages.

Messages are shown on the right side and appear as an envelope - They are reminders such as clean your air condenser filter, change your water filter, etc.

	O	f	f									
	O	n	/	O	f	f	M	o	d	e		
[▲	!]

For example, if alerts are appearing in the fourth line of the display:

1. Press Checkmark. A list of alerts will appear in the display.
2. Choose the alert you wish to address by moving the highlight brackets with the Down arrow.
3. Press Checkmark again. A screen appears with a line that can be selected for clearing the alert, a line for accessing a list of possible causes and a line for accessing service information.
4. Return to the Home screen by pressing the Left arrow until it appears.

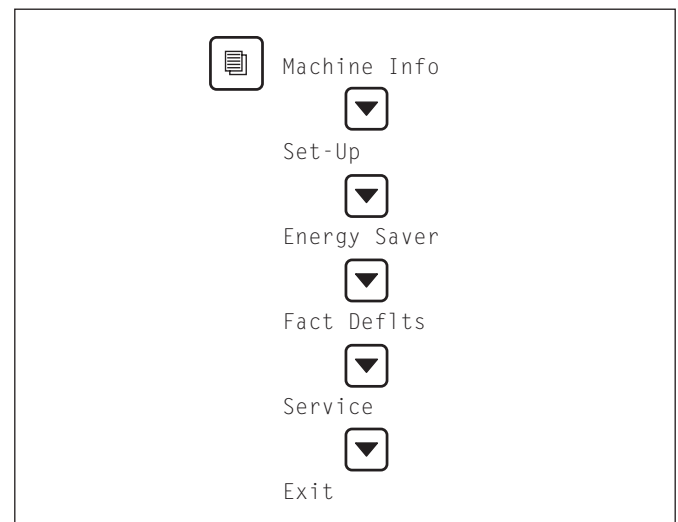

Main Menu



Main Menu

From the Home screen, press the Menu button to enter the Main menu, where you can choose to see machine information, make setup changes, set the Energy Saver mode, or enter the Service Menu.

MACHINE INFO MENU

From the Main menu, ensure that Machine Info is highlighted and press the Checkmark to view a list including capacity, model number, Ice Machine Head serial number, condenser serial number, warranty, installation date, date of manufacture and software versions. Use the Down arrow to highlight an item and use the Checkmark to view the information. Press the Left arrow to return to previous screens.

PASSWORD ENTRY

A password is not required, although a password can be turned on to prevent unauthorized control setting modification. You can use the Factory Default Password of "1234" or enter a four digit custom pin number of your choosing.

To turn on the password feature use the following procedure.

1. Press the Menu button.
2. From the Main menu, use the Down arrow to highlight Set-Up and press the Right arrow.
3. Use the Down arrow to highlight Password ON and press the Right arrow.
4. Press the Right arrow again with Enter Passwrd highlighted and an icon will flash.
5. Use the Up and Down arrows to enter the factory password (1, 2, 3, 4). Enter the number 1 in the flashing icon (first digit of the factory password).
6. Press the Right arrow to move to the next cell and use the Up and Down arrows to add the number 2. Repeat this process to add 3 and 4.
7. When the last number is entered press the Checkmark button to save your entry.

E	n	t	e	r	P	a	s	s	w	r	d	▲
[]
E	x	i	t									>

To enter a four digit password of your choosing use the following procedure.

1. Press the Menu button.
2. From the Main menu, use the Down arrow to highlight Set-Up and press the Right arrow.
3. Use the Down arrow to select Edit Password and press the Right arrow.
4. Using the Up and Down arrows, enter the first digit of the factory password in the flashing icon.
5. Press the right arrow to move to the next cell and use the Up and Down arrows to add the number 2. Repeat this process to add 3 and 4.
6. When the last number is entered press the Checkmark button.
7. Follow steps 4 and 5 and enter your 4 digit password.
8. When the last number is entered press the Checkmark button to save your entry.

Reset Password to Factory Defaults

The password can be reset to the factory defaults when required. The default factory password is 1234. To reset the ice machine to factory defaults, use the following procedure.

1. Press the Menu button.
2. From the Main menu, use the Down arrow to highlight Fact Deflts.
3. Press the Checkmark two times to reset the ice machine. The display will return to the Set-Up menu and the defaults listed below will be in effect. Refer to Set-Up Menu to adjust settings.

Setting	Default
Language	English
Time & Date	Central Time Zone
Time Config	Month/Day/Year/24 Hour
Units	Fahrenheit/Lbs/Gallons
Ice Clarity	Off
LCD Bright	Level 2
Password On/Off	Off
Clean Minder	Off
AuCS RunTime	Off
Air Filter	Off
Water Filter	Off
LuminIce™ Replace Bulb Reminder	Off



SET-UP MENU

From the Main menu, use the Down arrow to navigate to Set-Up and press the Checkmark. Select and customize machine settings on this menu. Press the Left arrow to return to previous screens.

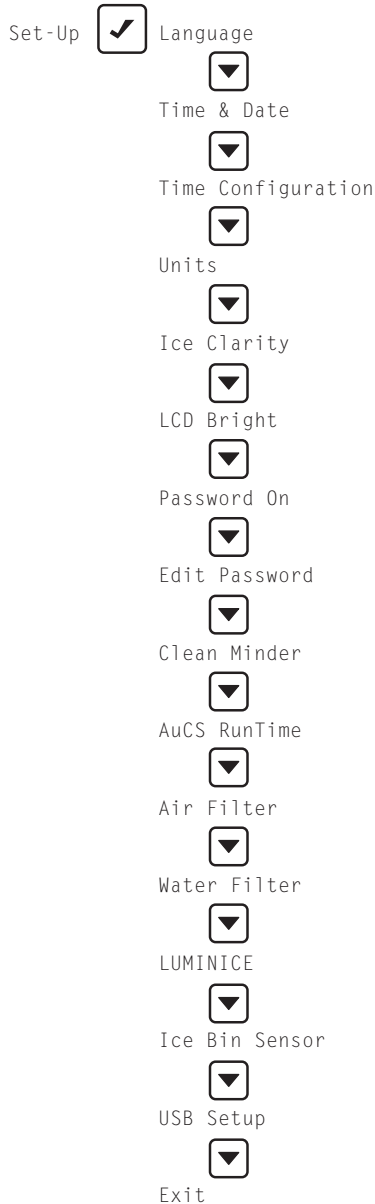

Set-Up Menu

Language

1. From the Set-Up menu, use the Down arrow to highlight Language.
2. Press the Checkmark. You can choose to view the display in a language other than English by highlighting your choice and pressing the Checkmark. Selecting one language will deselect the others.
3. When the check reflects your preference, use the Down arrow to navigate to Exit and press the Checkmark. The display will return to the Set-Up menu.

Time & Date

Refer to Operational Checks, page 25 for step-by-step instructions for setting the time and date.

[Mo	/	Day	/	Yr	(✓)]	▼
	Day	/	Mo	/	Yr	()		
	12		Hour			()		
	24		Hour			(✓)		▼

Time Configuration

1. From the Set-Up menu, use the Down arrow to highlight Time Config.
2. Press the Checkmark. On this screen, you can choose whether the date will be displayed as Mo/Day/Yr or Day/Mo/Yr by highlighting your choice and pressing the Checkmark. Selecting one will deselect the other.
3. You can also choose whether the time will be displayed as 12 Hour or 24 Hour by highlighting your choice and pressing the Checkmark. Selecting one will deselect the other.
4. When the two checks reflect your preference, use the Down arrow to navigate to Exit and press the Checkmark. The display will return to the Set-Up menu.



Units

1. From the Set-Up menu, use the Down arrow to highlight Units.
2. Press the Checkmark. On this screen, you can choose whether the ice machine will display measurements in Celsius or Fahrenheit, kilograms or pounds, and gallons or liters by highlighting your choice of each pair and pressing the Checkmark. Selecting one of each pair will deselect the other. Make sure to navigate with the Down arrow to make all three choices.
3. When the three checks reflect your preferences, use the Down arrow to navigate to Exit and press the Checkmark. The display will return to the Set-Up menu.

Ice Clarity

In areas with poor potable water quality, the ice machine makes cloudy ice. Setting Ice Clarity to ON will add additional water during the freeze cycle to dilute the water that contains a high content of dissolved solids in the water trough. This feature decreases production and increases water usage. A water filter is recommended to produce the highest quality ice while maintaining the least expensive mode of operation.

1. From the Set-Up menu, use the Down arrow to highlight Ice Clarity.
2. Press the Checkmark. On this screen, you can choose to turn the ice clarity feature ON or OFF by highlighting your choice and pressing the Checkmark. Selecting one will deselect the other.
3. When the check reflects your preference, use the Down arrow to navigate to Exit and press the Checkmark. The display will return to the Set-Up menu.

LCD Brightness

Here, the brightness of the LCD display can be adjusted.

1. From the Set-Up menu, use the Down arrow to highlight LCD Bright.
2. Press the Checkmark. You will see one to four checkmark symbols indicating the brightness levels of the display. Level 1 is 1 checkmark, level 2 is 2 checkmarks, etc.
3. Use the Up and Down arrows to select your preference.
4. When the number of checkmark symbols reflects your preference, press the Checkmark button. The display will return to the Set-Up menu.

Password On

A password can be added to prevent unauthorized changes to ice machine settings.

1. From the Set-Up menu, use the Down arrow to highlight Password On.
2. Enter the password and press the Checkmark.
3. Press the Left arrow to return to previous screens and to the Set-Up menu.

Edit Password

The password can be changed on this screen.

1. From the Set-Up menu, use the Down arrow to highlight Edit Passwrd.
2. Press the Checkmark and confirm current password.
3. Enter new password and press the Checkmark.
4. Press the Left arrow to return to previous screens and to the Set-Up menu.

Clean Minder

Clean Minder is a feature that displays a cleaning reminder at a set time interval.

1. From the Set-Up menu, use the Down arrow to highlight Clean Minder.
2. Press the Checkmark. On this screen, you can choose to turn the reminder ON or OFF by highlighting your choice and pressing the Checkmark. Selecting one will deselect the other.
3. You can also choose the time interval from this screen by highlighting Set Interval and pressing the Checkmark.
4. Press the Left arrow to return to previous screens and to the Set-Up menu.

AuCS Runtime

Automatic Cleaning System (AuCS) is an optional accessory and will perform a cleaning cycle at a set time interval.

1. From the Set-Up menu, use the Down arrow to highlight AuCS RunTime.
2. Press the Checkmark. On this screen, you can choose to turn the feature ON or OFF by highlighting your choice and pressing the Checkmark. Selecting one will deselect the other.
3. You can also choose the time interval from this screen by highlighting Set Interval and pressing the Checkmark.
4. Press the Left arrow to return to previous screens and to the Set-Up menu.

Air Filter

The ice machine has a feature that displays a clean air filter reminder at a set time interval.

1. From the Set-Up menu, use the Down arrow to highlight Air Filter.
2. Press the Checkmark. On this screen, you can choose to turn the reminder to AUTO or OFF by highlighting your choice and pressing the Checkmark. Selecting one will deselect the other.
3. You can also choose the time interval from this screen by highlighting Set Interval and pressing the Checkmark.
4. Press the Left arrow to return to previous screens and to the Set-Up menu.

Water Filter

The ice machine has a feature that displays a replace water filter reminder at a set time interval.

1. From the Set-Up menu, use the Down arrow to highlight Water Filter.
2. Press the Checkmark. You can record the filter type on this screen by highlighting Filter Type and pressing the Checkmark.
3. After making your selection, press the Left arrow to return to the previous screen.
4. On this screen, you can also choose to turn the reminder to AUTO or OFF by highlighting your choice and pressing the Checkmark. Selecting one will deselect the other.
5. You can further choose the time interval from this screen by highlighting Set Interval and pressing the Checkmark.
6. Press the Left arrow to return to previous screens and to the Set-Up menu.

LuminIce® II Reminder

The LuminIce® growth inhibitor recirculates the air in the ice machine foodzone over a UV bulb. This process will inhibit the growth of common micro-organisms on all exposed foodzone surfaces.

The LuminIce® II has a feature that displays a reminder to change its bulb every 12 months.

1. From the Set-Up menu, use the Down arrow to highlight LUMINICE.
2. Press the Checkmark. On this screen, you can choose to turn the reminder to AUTO or OFF by highlighting your choice and pressing the Checkmark. Selecting one will deselect the other.
3. When the check reflects your preference, use the Down arrow to navigate to Exit and press the Checkmark. The display will return to the Set-Up menu.

USB Setup

Refer to “Upgrading Firmware with a Flash Drive” and “Exporting Data to a Flash Drive” for more information on this setting.

ENERGY SAVER MENU

From the Main menu, use the Down arrow to navigate to Energy Saver and press the Checkmark. Set up an energy saving ice program, enable the Water Miser and view usage statistics from this menu. Press the Left arrow to return to previous screens.

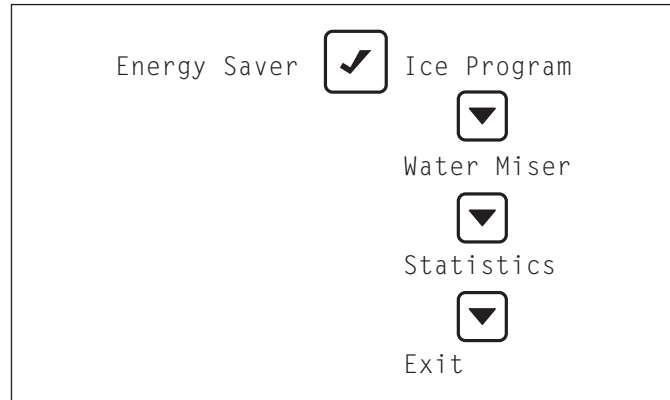

Energy Saver Menu

Ice Program

To save energy and water, the ice machine can be programmed to only power up during time periods that the ice will be used or when the bin level is being depleted by heavy use.

Important

Setting an ice program will take the ice machine out of the On/Off Mode and the Power button will be disabled.

1. In the Energy Saver menu, ensure that Ice Program is highlighted.
2. Press the Checkmark. On this screen, you can choose to turn on the time program or the bin level program by highlighting your choice and pressing the Checkmark. Selecting one will deselect the other. If one of them is selected and you wish to turn both off, highlight the choice and press Checkmark again.
3. If neither of the programs is selected, highlighting Next and pressing the Checkmark will simply return to the top of this screen. If one of the programs is selected, highlight Next and press the Checkmark to choose the times or bin levels. NOTE: For details on how to use the cursor for the time program, refer to “Display Panel Navigation” in this section.
4. Select Exit to return to previous screens and again to the Energy Saver menu.



Ice Bin Level Sensor

Ice bin sensor is an optional accessory that allows the ice level in the bin to be set to one of three different levels. The bin level can be set seasonally to match usage, which results in lower energy costs and fresher ice.

1. In the Energy Saver menu, ensure that Ice Program is highlighted and press checkmark.
2. Select Bin Level and press checkmark.
3. Select Settings and press checkmark.
4. On this screen you can choose to set the ice level to low, medium or high by highlighting your choice and pressing the Checkmark. Selecting one will deselect the other.

NOTE: On ice beverage models you must choose low for the control to function. The ice beverage sensor has one thermistor, while the bin level sensor has three.

5. Select - Exit, Save changes, Yes and then Done.

When the check reflects your preference, use the Down to navigate to Exit and press the Checkmark. The display will return to the Set-up menu.

Water Miser

Water Miser is a feature that reduces water usage by eliminating flush cycles. Enabling this feature is only recommended for systems with de-ionized or reverse osmosis filtering.

1. From the Energy Saver menu, use the Down arrow to highlight Water Miser.
2. Press the Checkmark. On this screen, you can choose to turn the Water Miser ON or OFF by highlighting your choice and pressing the Checkmark. Selecting one will deselect the other.
3. Press the Left arrow to return to previous screens and to the Energy Saver menu.

Statistics

1. From the Energy Saver menu, use the Down arrow to highlight Statistics.
2. Press the Checkmark. Choose to view ice production, potable water usage or energy usage statistics by highlighting your choice and pressing the Checkmark.
3. Press the Left arrow to return to previous screens and to the Energy Saver menu.

Factory Defaults

The entire setup can be reset to the factory defaults.

1. From the Set-Up menu, use the Down arrow to highlight Fact Default.
2. Press the Checkmark two times to reset the ice machine. The display will return to the Set-Up menu.

Service Menu

From the Main menu, use the Down arrow to navigate to Service and press the Checkmark. This menu is intended for the use of trained service personnel.

Data History

Press the Checkmark with Data History highlighted to view a list of eight-digit dates (Current, Current + 1 ... Current + 5), along with Lifetime (be sure to use the Down arrow to reveal all the available information).

For each of the dates, use the Checkmark to view:

- Minimum Freeze Cycle
- Maximum Freeze Cycle
- Minimum Harvest Cycle
- Maximum Harvest Cycle
- Maximum Temperature DeltaT3 to T4
- Delta T3 & T4
- Delta
- T3
- T4
- Run Time
- Ice Production
- Cycle Count
- Potable Water Usage
- Clean Cycle
- Exit

For Lifetime, use the Checkmark to view:

- Install Date (Install)
- Control Board Replacement date
- Control Board Date Of Manufacture (DOM)
- Run Time
- Cycle Count
- Potable Water Usage
- Clean Cycles
- Exit

Real Time Data

Press the Checkmark with RealTime Data highlighted to get readings on Time & Temp, Inputs and Outputs.

Diagnostics

Press the Checkmark with Diagnostics highlighted to enter screens where you can run diagnostics on the control board, sensors and switches.

Manual Harvest

Press the Checkmark with Man Harvest highlighted to enter a screen where you can initiate a manual harvest.

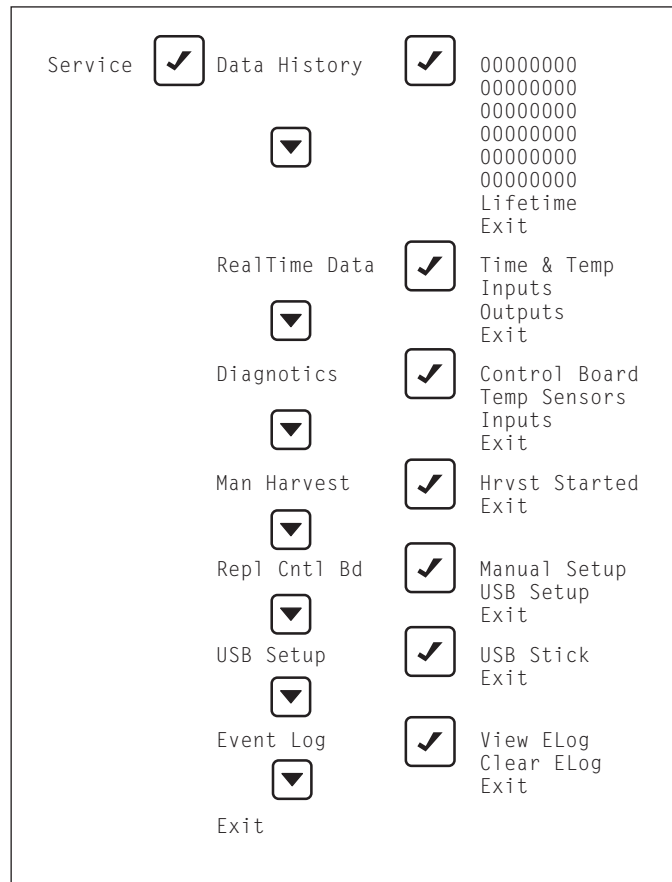

Service Menu



Ice Making Sequence of Operation

Ice machines and storage bins produce and store ice for human consumption and product cooling.

NOTE: The power button must be depressed and the water curtain/ice dampers must be in place on the evaporator before the ice machine will start.

Water Purge Cycle

The ice machine purges any remaining water from the water trough down the drain.

Freeze Cycle

Water flows across the evaporator and the refrigeration system chills the evaporator. Ice builds on the evaporator and the freeze cycle continues until the ice thickness probe senses a sheet of ice has formed. The ice thickness probe signals the control board to start a harvest.

Harvest Cycle

Any remaining water is purged down the drain as refrigerant gas warms the evaporator. When the evaporator warms, the sheet of cubes slides off the evaporator and into the storage bin. If all cubes fall clear of the water curtain (or ice damper) the ice machine starts another freeze cycle.

Off Cycle

If the water curtain or ice damper are held open by ice cubes the ice machine shuts off. When the water curtain or ice damper closes, the ice machine starts a new cycle at the water purge.

Control Board Timers

The control board has the following non-adjustable timers:

- The ice machine control board will set its own install date after 100 freeze and harvest cycles.
- The ice machine is locked into the freeze cycle for 6 minutes before a harvest cycle can be initiated.
- The maximum freeze time is 60 minutes, at which time the control board automatically initiates a harvest sequence.
- The maximum harvest time is 3.5 minutes. The control board automatically initiates a freeze sequence when these times are exceeded.

Safety Limits

Safety limits are stored and indicated by the control board after three cycles. The number of cycles required to stop the ice machine varies for each safety limit.

- Safety Limit 1 - If the freeze time reaches 60 minutes, the control board automatically initiates a harvest cycle. If 6 consecutive 60-minute freeze cycles occur, the ice machine stops.
- Safety Limit 2 - If the harvest time reaches 3.5 minutes, the control board automatically returns the ice machine to the freeze cycle. If 500 consecutive 3.5 minute harvest cycles occur, the ice machine stops.

A safety limit is indicated by a flashing control board light labeled SL1 or SL2. Refer to Section 5 if you receive a safety limit indication.

Safe Operation Mode

Allows the ice machine to operate up to 72 hours if the ice thickness probe and/or water level probe sensors fail.

- When the control board starts the safe mode, an alert is flashed on the LCD display to notify the end-user they have a production problem.
- The control board automatically initiates and monitors the safe mode. The control will automatically exit the safe mode if a normal signal is received from the input.
- After 72 hours, the control board will enter a standby mode and turn off.

OPERATIONAL CHECKS

General

Manitowoc ice machines are factory-operated and adjusted before shipment. Normally, new installations do not require any adjustment.

To ensure proper operation, always follow the Operational Checks:

- when starting the ice machine for the first time
- after a prolonged out of service period
- after cleaning and sanitizing

NOTE: Routine adjustments and maintenance procedures are not covered by the warranty.

MINIMUM/MAXIMUM SLAB WEIGHT

Adjust ice thickness to meet chart specifications.

Model	Minimum Ice Weight Per Cycle lbs Grams	Maximum Ice Weight Per Cycle lbs Grams
i300	2.40 lbs 1089 grams	2.80 lbs 1270 grams
i320 - i450 - i520	3.40 lbs 1542 grams	3.90 lbs 1769 grams
i500 - i680 - i686 i690 - i696	4.60 lbs 2087 grams	5.20 lbs 2359 grams
i600 - i606	4.12 lbs 1869 grams	4.75 lbs 2155 grams
i850 - i870 - i890 - i976	5.75 lbs 2608 grams	6.50 lbs 2948 grams
i906 - i1000 - i1006 - i1070	6.2 lbs 2812 grams	7.2 lbs 3266 grams
i1200	7.50 lbs 3402 grams	8.20 lbs 3719 grams
i1090	7.50 lbs 3402 grams	8.50 lbs 3856 grams
i1400 - i1406	10.25 lbs 4649 grams	11.50 lbs 5216 grams
i1470	12.0 lbs 5443 grams	14.0 lbs 6350 grams
i1800	13.20 lbs 5987 grams	14.80 lbs 6713 grams
i1870 - i2170 - i2176	15.5 lbs 7031 grams	16.75 lbs 7598 grams

Ice Thickness Check

After a harvest cycle, inspect the ice cubes in the ice storage bin. The ice thickness probe is factory-set to maintain the ice bridge thickness at 1/8" (3 mm).

NOTE: Make sure the water curtain is in place when performing this check. It prevents water from splashing out of the water trough.

1. Inspect the bridge connecting the cubes. It should be about 1/8" (3 mm) thick.
2. If adjustment is necessary, turn the ice thickness probe adjustment screw clockwise to increase bridge thickness, counterclockwise to decrease bridge thickness. Set at 9/32" (7 mm) gap between ice thickness probe and evaporator as starting point, then adjust to achieve a 1/8" (3 mm) bridge thickness.

NOTE: Turning the adjustment one-third of a turn will change the ice thickness about 1.5 mm (1/16").

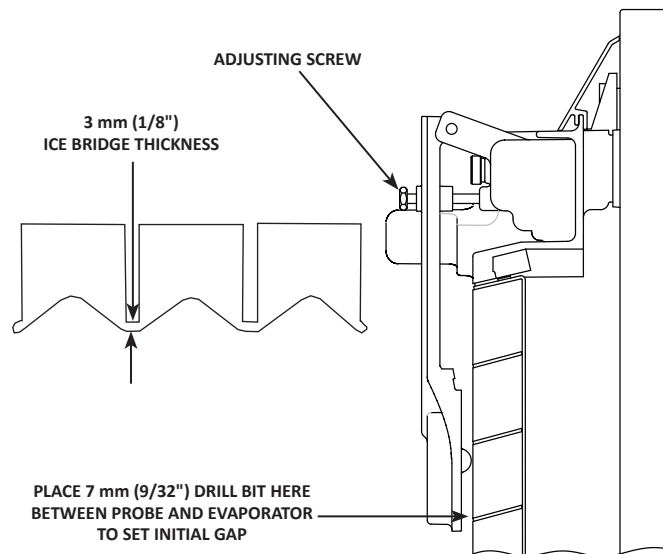

Ice Thickness Check

Make sure the ice thickness probe wire doesn't restrict movement of the probe.



Section 4

Maintenance

Cleaning and Sanitizing

General

You are responsible for maintaining the ice machine in accordance with the instructions in this manual. Maintenance procedures are not covered by the warranty.

Clean and sanitize the ice machine every six months for efficient operation. If the ice machine requires more frequent cleaning and sanitizing, consult a qualified service company to test the water quality and recommend appropriate water treatment. An extremely dirty ice machine must be taken apart for cleaning and sanitizing.

Manitowoc Ice Machine Cleaner and Sanitizer are the only products approved for use in Manitowoc ice machines.

Caution

Use only Manitowoc approved Ice Machine Cleaner and Sanitizer for this application (Manitowoc Cleaner part number 94-0546-3 and Manitowoc Sanitizer part number 94-0565-3). It is a violation of Federal law to use these solutions in a manner inconsistent with their labeling. Read and understand all labels printed on bottles before use.

Caution

Do not mix Cleaner and Sanitizer solutions together. It is a violation of Federal law to use these solutions in a manner inconsistent with their labeling.

Warning

Wear rubber gloves and safety goggles (and/or face shield) when handling Ice Machine Cleaner or Sanitizer.

Cleaning/Sanitizing Procedure

This procedure must be performed a minimum of once every six months.

- The ice machine and bin must be disassembled cleaned and sanitized.
- All ice produced during the cleaning and sanitizing procedures must be discarded.
- Removes mineral deposits from areas or surfaces that are in direct contact with water.

Preventative Maintenance Cleaning Procedure

- This procedure cleans all components in the water flow path, and is used to clean the ice machine between the bi-yearly cleaning/sanitizing procedure.

Exterior Cleaning

Clean the area around the ice machine as often as necessary to maintain cleanliness and efficient operation.

Wipe surfaces with a damp cloth rinsed in water to remove dust and dirt from the outside of the ice machine. If a greasy residue persists, use a damp cloth rinsed in a mild dish soap and water solution. Wipe dry with a clean, soft cloth.

The exterior panels have a clear coating that is stain resistant and easy to clean. Products containing abrasives will damage the coating and scratch the panels.

- Never use steel wool or abrasive pads for cleaning.
- Never use chlorinated, citrus based or abrasive cleaners on exterior panels and plastic trim pieces.

Cleaning/Sanitizing Procedure

⚠ Caution

Use only Manitowoc approved Ice Machine Cleaner and Sanitizer for this application (Manitowoc Cleaner part number 94-0546-3 and Manitowoc Sanitizer part number 94-0565-3). It is a violation of Federal law to use these solutions in a manner inconsistent with their labeling. Read and understand all labels printed on bottles before use.

CLEANING PROCEDURE

⚠ Caution

Do not mix Cleaner and Sanitizer solutions together. It is a violation of Federal law to use these solutions in a manner inconsistent with their labeling.

⚠ Warning

Wear rubber gloves and safety goggles (and/or face shield) when handling Ice Machine Cleaner or Sanitizer.

Ice machine cleaner is used to remove lime scale and mineral deposits. Ice machine sanitizer disinfects and removes algae and slime.

NOTE: Although not required and dependent on your installation, removing the ice machine top cover may allow easier access.

Step 1 Open the front door to access the evaporator compartment. Ice must not be on the evaporator during the clean/sanitize cycle. Follow one of the methods below:

- Press the power switch at the end of a harvest cycle after ice falls from the evaporator(s).
- Press the power switch and allow the ice to melt.

⚠ Caution

Never use anything to force ice from the evaporator. Damage may result.

Step 2 Remove all ice from the bin/dispenser.

Step 3 Press the Cleaning button. Water will flow through the water dump valve and down the drain. Wait until the water trough refills and the display indicates Add Chemical (approximately 1 minute), then add the proper amount of ice machine cleaner.

Model	Amount of Cleaner
I0300/I0320/I0520	90 ml (3 oz)
I0450/I0500/I0600/I0606 I0686C/IB0690C/I0850/IB0980C IB0896C/I0870C/I0876C I0906/I0976C/I1076C I1000/IB1090C/IB1096C I1100/I1106/I1070C/I1176C I1200	150 ml (5 oz)
IB0690C/IB0890C/IB1090C	150 ml (5 oz)
I1400/I1406/I1470C/I1476C I1800/I1806/I1870C/I1876C I2170C/I2176C	265 ml (9 oz)
I3300/I3070C	475 ml (16 oz)

Step 4 Wait until the clean cycle is complete (approximately *24 minutes). Then disconnect power to the ice machine (and dispenser when used).

⚠ Warning

Disconnect the electric power to the ice machine at the electric service switch box.

Step 5 Remove parts for cleaning.

Please refer to the proper parts removal for your ice machine. Continue with step 6 when the parts have been removed.

Single Evaporator Ice Machines - page 42

Multiple Evaporator Ice Machines - page 43



Step 6 Mix a solution of cleaner and lukewarm water. Depending upon the amount of mineral buildup, a larger quantity of solution may be required. Use the ratio in the table below to mix enough solution to thoroughly clean all parts.

Solution Type	Water	Mixed With
Cleaner	4 L (1 gal)	475 ml (16 oz) cleaner

Step 7 Use half of the cleaner/water mixture to clean all components. The cleaner solution will foam when it contacts lime scale and mineral deposits; once the foaming stops, use a soft-bristle nylon brush, sponge or cloth (NOT a wire brush) to carefully clean the parts. Soak parts for 5 minutes (15 - 20 minutes for heavily scaled parts). Rinse all components with clean water.

Step 8 While components are soaking, use half of the cleaner/water solution to clean all foodzone surfaces of the ice machine and bin (or dispenser). Use a nylon brush or cloth to thoroughly clean the following ice machine areas:

- Side walls
- Base (area above water trough)
- Evaporator plastic parts - including top, bottom and sides
- Bin or dispenser

Rinse all areas thoroughly with clean water.

SANITIZING PROCEDURE

Step 9 Mix a solution of sanitizer and lukewarm water.

Solution Type	Water	Mixed With
Sanitizer	12 L (3 gal)	60 ml (2 oz) sanitizer

Step 10 Use half of the sanitizer/water solution to sanitize all removed components. Use a spray bottle to liberally apply the solution to all surfaces of the removed parts or soak the removed parts in the sanitizer/water solution. Do not rinse parts after sanitizing.

Step 11 Use half of the sanitizer/water solution to sanitize all foodzone surfaces of the ice machine and bin (or dispenser). Use a spray bottle to liberally apply the solution. When sanitizing, pay particular attention to the following areas:

- Side walls
- Base (area above water trough)
- Evaporator plastic parts - including top, bottom and sides
- Bin or dispenser

Do not rinse the sanitized areas.

Step 12 Replace all removed components.

Step 13 Wait 20 minutes.

Step 14 Reapply power to the ice machine and perform the following key strokes.

- Press Cleaning button
- Press Checkmark
- Press Checkmark to select Auto Ice - on

Step 15 Wait until the water trough refills and the display indicates to add solution (approximately 1 minute). Add the proper amount of Manitowoc Ice Machine Sanitizer to the water trough by pouring between the water curtain and evaporator.

Model	Amount of Sanitizer
I0300/I0320/I0520	90 ml (3 oz)
I0450/I0500/I0600/I0606 I0686C/IB0690C/I0850/IB0980C IB0896C/I0870C/I0876C I0906/I0976C I1076C/I1000/IB1090C I1100/I1106/I1070C/I1176C I1200	90 ml (3 oz)
IB1090C/IB1096C	104 ml (3.5 oz)
I1400/I1406C/I1800/I1806C	180 ml (6 oz)
I1470C/I1476C/I1870C/I1876C I2170C/I2176C	355 ml (12 oz)
I3300/I3070C	740 ml (25 oz)

Step 16 Close and secure the front door. The ice machine will automatically start ice making after the sanitize cycle is complete (approximately 24 minutes).



Parts Removal for Cleaning/Sanitizing

SINGLE EVAPORATOR ICE MACHINES

A. Remove the water curtain

- Gently flex the curtain in the center and remove it from the right side.
- Slide the left pin out.

B. Remove the ice thickness probe

- Compress the hinge pin on the top of the ice thickness probe.
- Pivot the ice thickness probe to disengage one pin then the other. The ice thickness probe can be cleaned at this point without complete removal. If complete removal is desired, disconnect the ice thickness control wiring from the control board.

C. Remove the water trough

- Depress tabs on right and left side of the water trough.
- Allow front of water trough to drop as you pull forward to disengage the rear pins.

D. Remove the water level probe

- Pull the water level probe straight down to disengage.
- Lower the water level probe until the wiring connector is visible.
- Disconnect the wire lead from the water level probe.
- Remove the water level probe from the ice machine.

E. Remove the water distribution tube

NOTE: Thumbscrews for the distribution tube are retained to prevent loss. Loosen thumbscrews, but do not pull thumbscrews out of distribution tube.

- Loosen the two outer screws (do not remove screws completely because they are retained to prevent loss) and pull forward on the distribution tube to release from slip joint.
- Disassemble distribution tube by loosening the two (2) middle thumbscrews and dividing the distribution tube into two pieces.

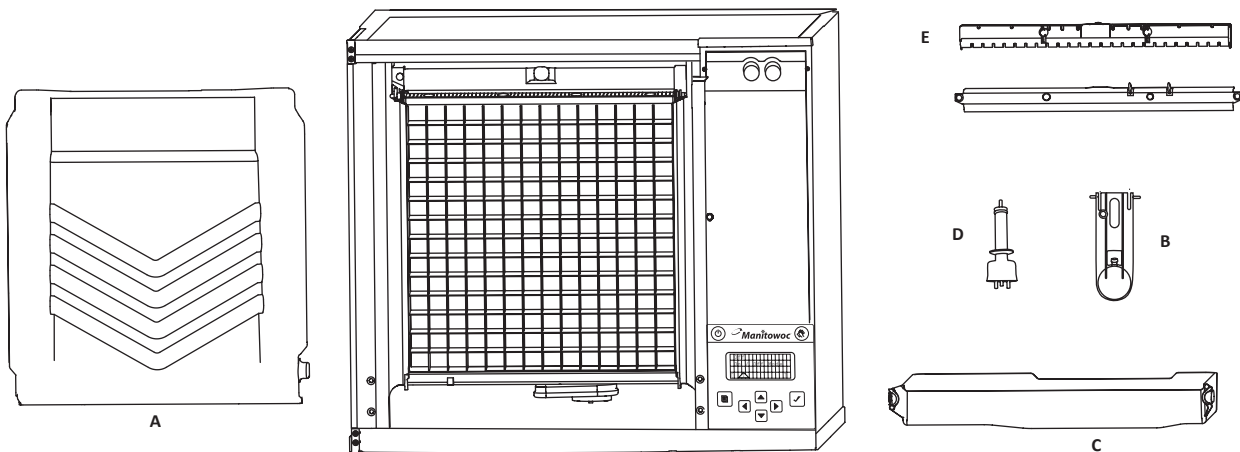

MULTIPLE EVAPORATOR ICE MACHINES

A. Remove front evaporator shield

- Remove four quarter-turn connectors.
- Remove splash shield.

B. Remove left and right evaporator top covers

- Remove two thumbscrews from the front of each evaporator top cover.
- Lift front of cover, pull forward to remove.

C. Remove splash shields

NOTE: Each evaporator has a splash shield that must be removed - total of four splash shields.

- Grasp the top center of splash shields.
- Lift up and then out.

D. Remove ice thickness probe

- Compress the hinge pin on the top of the ice thickness probe.
- Pivot the ice thickness probe to disengage one pin then the other. The ice thickness probe can be cleaned at this point without complete removal. If complete removal is desired, disconnect the ice thickness control wiring from the control board.

E. Remove the water pump assembly

- Disconnect the vinyl distribution tube from both water pumps.
- Disconnect the water pump and water level probe electrical connections.

- After the wires are disconnected, remove the two thumbscrews and lift the water pump assembly out of the ice machine.
- Remove the thumbscrews securing the water pumps (2 each pump) and remove water pumps. Do not immerse the water pump motor in cleaner or sanitizer solutions.
- Remove the water level probe from the assembly housing.

F. Remove the water trough

- Pull forward on the water trough to remove.

G. Remove distribution tubes

NOTE: Each evaporator has a distribution that must be removed - total of four distribution tubes.

- Thumbscrews for the distribution tube are retained to prevent loss. Loosen thumbscrews, but do not pull thumbscrews out of distribution tube.
- Loosen the two outer screws and pull forward on the distribution tube to release from slip joint.
- Disassemble distribution tube by loosening the two (2) middle thumbscrews and dividing the distribution tube into two pieces.

H. Remove ice dampers

NOTE: Each evaporator has an ice damper that must be removed - total of four ice dampers.

- Grasp ice damper and apply pressure toward the back mounting bracket.
- Apply pressure to the front mounting bracket with thumb.
- Pull ice damper downward when the front ice damper pin disengages.

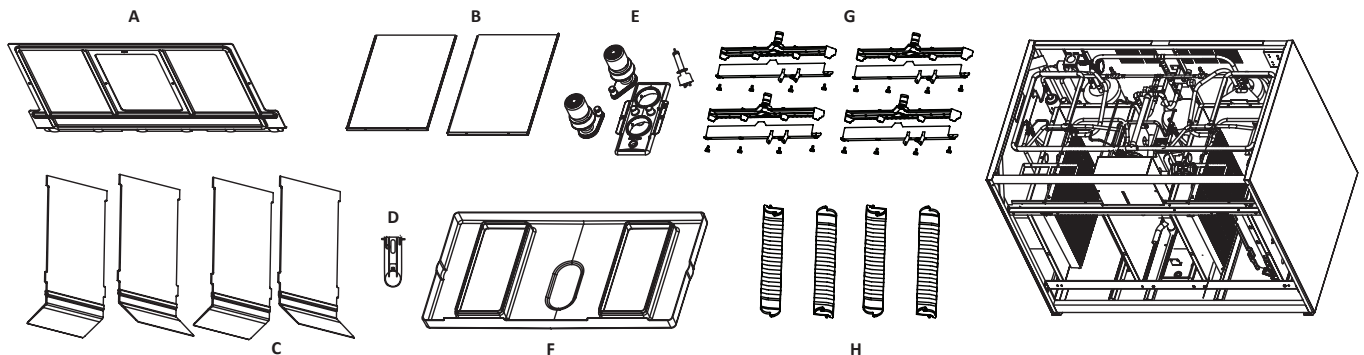

Preventative Maintenance Cleaning Procedure

This procedure cleans all components in the water flow path, and is used to clean the ice machine between the bi-yearly cleaning/sanitizing procedure.

Ice machine cleaner is used to remove lime scale and mineral deposits. Ice machine sanitizer disinfects and removes algae and slime.

NOTE: Although not required and dependent on your installation, removing the ice machine top cover may allow easier access.

Step 1 Ice must not be on the evaporator during the clean/sanitize cycle. Follow one of the methods below:

- Press the power switch at the end of a harvest cycle after ice falls from the evaporator(s).
- Press the power switch and allow the ice to melt.

⚠ Caution

Never use anything to force ice from the evaporator. Damage may result.

Step 2 Open the front door to access the evaporator.

Step 3 Press the Cleaning button. Water will flow through the water dump valve and down the drain. Wait until the water trough refills and the display indicates Add Chemical (approximately 1 minute), then add the proper amount of ice machine cleaner.

Model	Amount of Cleaner
I0300/I0320/I0520	90 ml (3 oz)
I0450/I0500/I0600/I0606 I0686C/I0690C/I0850/I0980C I0896C/I0870C/I0876C I0906/I0976C/I1076C I1000/I090C/I096C I1100/I1106/I1070C/I1176C I1200	150 ml (5 oz)
IB0690C/IB0890C/IB1090C	150 ml (5 oz)
I1400/I1406/I1470C/I1476C I1800/I1806/I1870C/I1876C I2170C/I2176C	265 ml (9 oz)
I3300/I3070C	475 ml (16 oz)

Step 4 Close and secure the front door. The ice machine will automatically start ice-making after the clean cycle is complete (approximately 24 minutes).

Cleaning the Condenser Filter

The washable filter on self-contained ice machines is designed to catch dust, dirt, lint and grease. Clean the filter with a mild soap and water.

Cleaning the Condenser

General

⚠ Warning

Disconnect electric power to the ice machine head section and the remote condensing unit at the electric service switches before cleaning the condenser.

A dirty condenser restricts airflow, resulting in excessively high operating temperatures. This reduces ice production and shortens component life.

- Clean the condenser at least every six months.

⚠ Warning

The condenser fins are sharp. Use care when cleaning them.

- Shine a flashlight through the condenser to check for dirt between the fins.
- Blow compressed air or rinse with water from the inside out (opposite direction of airflow).
- If dirt still remains, call a service agent to clean the condenser.



Section 5 Troubleshooting

Before Calling for Service Checklist

If a problem arises during operation of your ice machine, follow the checklist below before calling service. Routine adjustments and maintenance procedures are not covered by the warranty.

Problem	Possible Cause	To Correct
Ice machine does not operate.	No electrical power to the ice machine and/or condensing unit.	Replace the fuse/reset the breaker/turn on the main switch.
	High pressure cutout tripping.	Clean condenser coil. (See page 44)
	Energy Saver or other field entered programming is stopping ice machine.	Reset to factory defaults. (See page 35)
	Water curtain off or stuck open.	Water curtain must be installed and swinging freely.
	Ice machine is not turned on.	Press power button, display must indicate "Making Ice".
	IB Models Only - Dispenser level thermostat is open.	Adjust thermostat to maintain correct dispenser level.
Ice machine stops, and can be restarted by pressing the power switch.	Safety limit feature stopping the ice machine.	Refer to "Safety Limit Feature" on the next page.
Ice machine does not release ice or is slow to harvest.	Ice machine is dirty.	Clean and sanitize the ice machine. (See page 40)
	Ice machine is not level.	Level the ice machine.
	Low air temperature around ice machine head section.	Air temperature must be at least 2°C.
	Fan cycle control does not de-energize condenser fan motor.	Call for service.
	Water regulating valve incorrectly adjusted or will not close.	Check for water at condenser drain outlet in harvest cycle. Contact a qualified service company to adjust/replace valve if water is present.
Ice machine does not cycle into harvest mode.	The six-minute freeze time lock-in has not expired yet.	Wait for the freeze lock-in to expire.
	Ice thickness probe is dirty.	Clean and sanitize the ice machine. (See page 40)
	Ice thickness probe is disconnected.	Connect the probe to the control board.
	Ice thickness probe is out of adjustment.	Adjust the ice thickness probe. (See page 26)
	Uneven ice fill (thin at the top of evaporator).	Verify sufficient water level in sump trough. Contact a qualified service company to check refrigeration system.
Ice quality is poor (soft or not clear).	Poor incoming water quality.	Contact a qualified service company to test the quality of the incoming water and make appropriate filter recommendations.
	Water filtration is poor.	Replace the filter.
	Ice machine is dirty.	Clean and sanitize the ice machine. (See page 40)
	Water dump valve is not working.	Disassemble and clean the water dump valve.
	Water softener is working improperly (if applicable).	Repair the water softener.

Problem	Possible Cause	To Correct
Ice machine produces shallow or incomplete cubes, or the ice fill pattern on the evaporator is incomplete.	Ice thickness probe is out of adjustment.	Adjust the ice thickness probe. (See page 26)
	Water trough level is too low.	Check the water level probe position.
	Water inlet valve filter screen is dirty.	Remove the water inlet valve and clean the filter screen.
	Water filtration is poor.	Replace the filter.
	Hot incoming water.	Connect the ice machine to a cold water supply. (See page 16)
	Water inlet valve is not working.	Replace the water inlet valve.
	Incorrect incoming water pressure.	Water pressure must be 140 kPa - 550 kPa.
Low ice capacity.	Ice machine is not level.	Level the ice machine.
	Water inlet valve filter screen is dirty.	Remove the water inlet valve and clean the filter screen.
	Incoming water supply is shut off.	Open the water service valve.
	Water inlet valve stuck open or leaking.	Press the power button and turn off the ice machine, if water continues to enter water trough, replace the water inlet valve.
	The condenser is dirty.	Clean the condenser.
	High air temperature entering condenser.	Refer to air temperature chart for your model on page 9.
	The harvest assist air compressor is not functioning.	Call for service.

Safety Limit Feature

In addition to the standard safety controls, such as the high pressure cutout, your Manitowoc ice machine features built-in safety limits which will stop the ice machine if conditions arise which could cause a major component failure.

Before calling for service, re-start the ice machine using the following procedure:

1. Press the power button. The display reads "Off". Press the power button again, and the display reads "Making Ice".
 - A. If the safety limit feature has stopped the ice machine, it will restart after a short delay. Proceed to step 2.
 - B. If the ice machine does not restart, see "Ice machine does not operate" on the previous page.
2. Allow the ice machine to run to determine if the condition repeats.
 - A. If the ice machine stops again, the condition has repeated. Call for service.
 - B. If the ice machine continues to run, the condition has corrected itself. Allow the ice machine to continue running.





MANITOWOC ICE
2110 SOUTH 26TH STREET, MANITOWOC, WI 54220

800-545-5720
WWW.MANITOWOCICE.COM

