

SENCOR®

SAC ST0180C



SPOT AIR CONDITIONER

Translation of the original manual



SENCOR®

SAC ST0180C

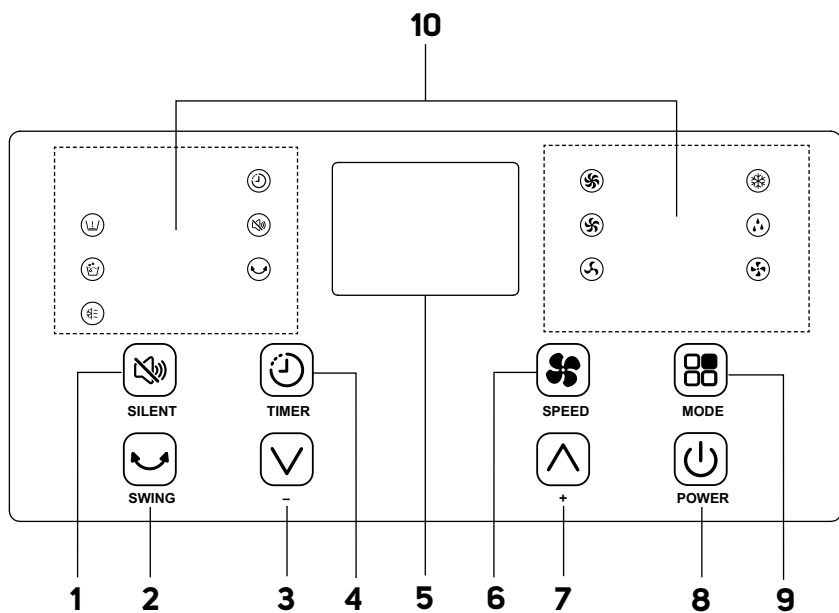
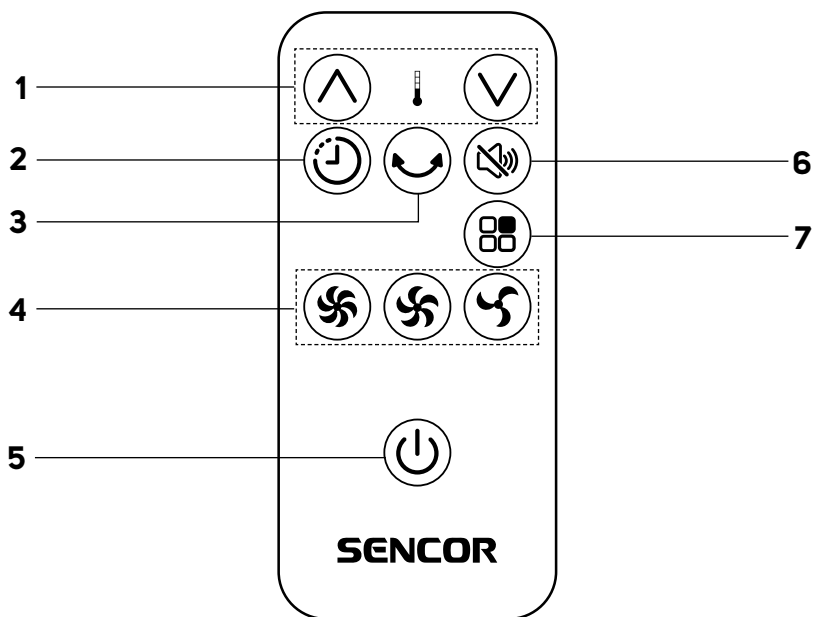

C**D**

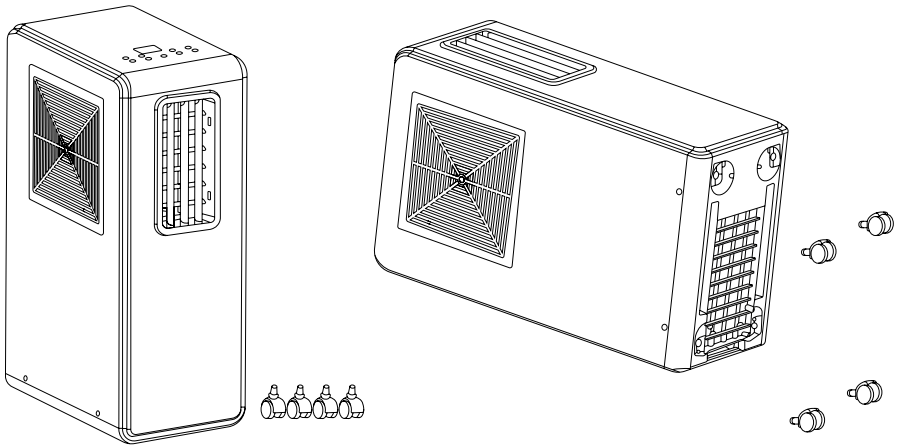
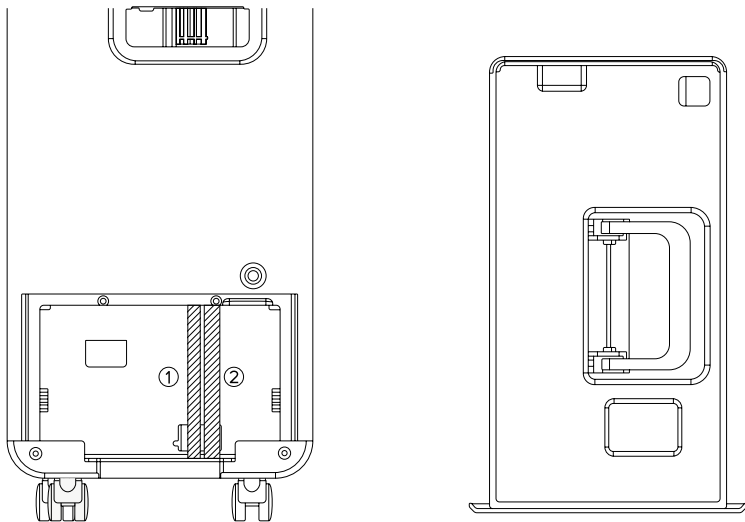
E**F**

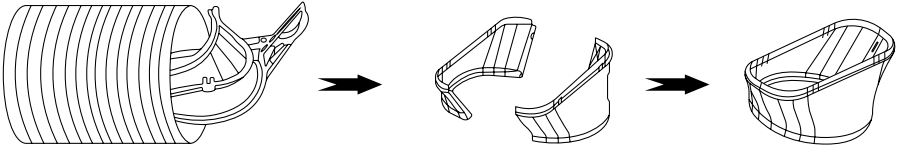
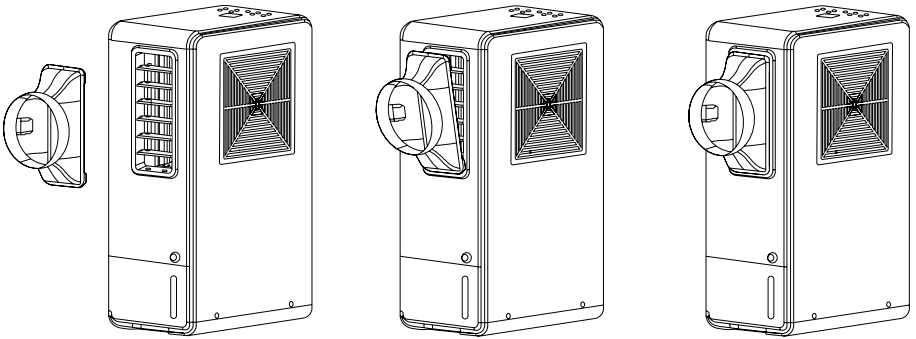
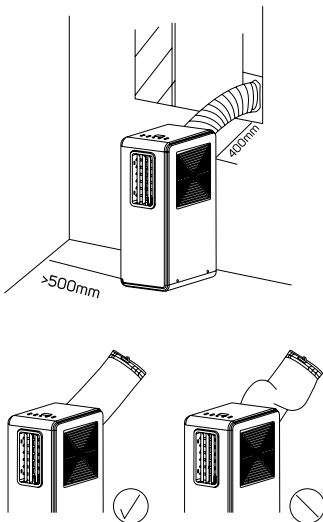
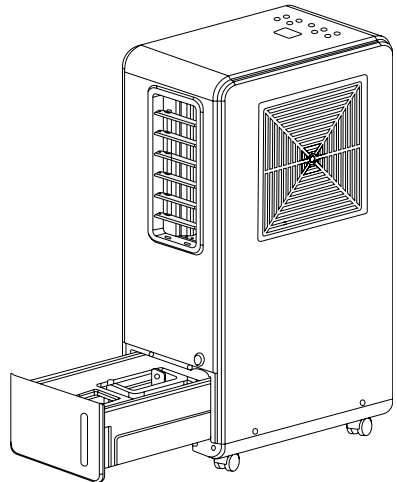
G1**G2****G3****H**

I

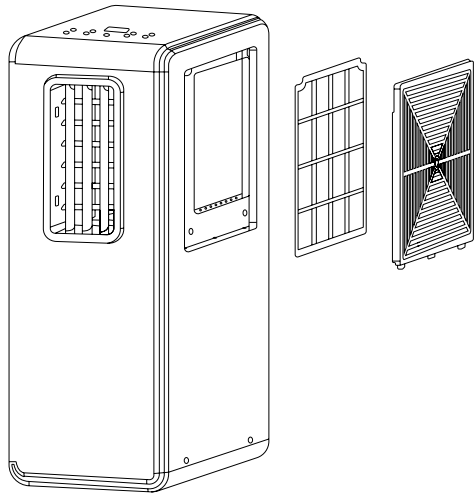
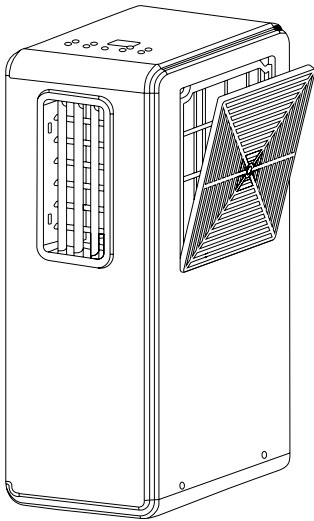

IMPORTANT SAFETY INSTRUCTIONS

READ CAREFULLY AND STORE FOR FUTURE USE.

- This appliance may be only used by children aged 8 years and older and by persons with physical, sensory or mental impairments or lack of experience and knowledge, if they are supervised or have been instructed on the safe use of the appliance and understand the potential hazards.
- Cleaning and maintenance must not be performed by unsupervised children. Children must not play with the appliance.
- If the power cord is damaged, it must be replaced by an authorised service centre or by another similarly qualified person, this will prevent the creation of a dangerous situation. It is forbidden to use the appliance if it has a damaged power cord.
- The appliance must be installed in accordance with national installation codes.
- The appliance must be stored in a manner that prevents its mechanical damage.
- The appliance must be stored in a well ventilated location, where the dimensions of the room must correspond to the dimensions specified for its operation.
- The appliance must be stored in a room where an open flame is not continuously in use (e.g. running gas

appliance) or where there are sources of ignition (e.g. running electrical heating element).

- Before connecting the appliance to a power socket, check that the rated voltage on its rating label matches the electrical voltage in the power socket.
- Connect the appliance only to a properly earthed socket.
- The power socket must be freely accessible so that it is possible to quickly disconnect the power cord from the power source if necessary.
- The appliance is designed for use in household, offices and similar types of areas. Do not use it in rooms where it could be exposed to dripping or spraying water, where it could be exposed to direct sunlight, in areas where chemical or explosive substances are stored, in industrial surroundings or outdoors. Do not use it in the vicinity of a bath, shower, swimming pool, etc.
- Keep the appliance away from open flames or heat sources.
- Do not place the appliance on unstable surfaces such as carpets with very long and thick fibres.
- The appliance may only be used on a dry, stable, smooth and horizontal surface.
- The appliance is equipped with travel wheels so pay extra attention when handling it so that it does not fall down stairs or travel down from sloped areas. If necessary secure the wheels using the stoppers.
- Only use original parts to assemble the appliance. Before starting to assemble the appliance, make sure that it is turned off and disconnected from the power socket.
- Prior to connecting the appliance to a power socket, make sure that the appliance is correctly assembled according to the instructions in this user's manual.
- Do not touch the appliance with wet or damp hands. This applies especially when it is connected to a power socket.
- Do not submerge the appliance in water or in any other liquid.
- Do not cover or insert anything into the air inlet or air outlet openings. This could damage the appliance.
- During operation, there must be sufficient space for air circulation with at least 30 cm of free space on all sides.
- Do not expose yourself to a cold air current for a long time. This could have a negative effect on your health.
- To turn the appliance on or off, always use the appropriate buttons on the control panel. Do not turn off the appliance by disconnecting the power cord from the power socket.
- Always turn off the appliance and disconnect it from the power socket when leaving it without supervision, when not using it and before moving, disassembling or cleaning it.
- Do not attempt to remove the outer case of the appliance.
- Unplug the appliance from the power socket by pulling the plug, not the power cord. Otherwise, damage to the power cable or socket could occur.
- Do not use the appliance if damaged in any way, or with a damaged mains cable or plug.
- Store the appliance in a vertical position. It may only be transported in the vertical position. If you have already used the appliance, check that all the condensate has been drained. After transporting it, wait at least 1 hour before using the appliance.
- Do not use the appliance if it is not working correctly, if it has been damaged or has been submerged in water. To avoid a hazardous situation arising, do not repair the device yourself or modify it in any way. All repairs should be carried out by an authorised service centre. Tampering with the appliance may result in the loss of your legal rights regarding faulty performance or warranty for quality.
- This appliance is intended for use by experts or trained personnel in stores, light industry and in agriculture, or for commercial use by ordinary people.

Special safety instructions regarding batteries

- The remote control uses a type of battery to power it: 1x CR2032.
- The batteries are not a toy. Ensure that children do not play with the batteries. Keep new and old batteries out of the reach of children. Batteries pose a serious health risk in the event of ingestion (chemical burns with serious consequences or suffocation) within a very short time. If the battery is suspected to be ingested, seek medical help immediately.
- Use only the battery types recommended by the manufacturer.
- Do not combine new and old batteries, various brands or types of batteries (alkaline or rechargeable).
- The batteries must be correctly inserted according to the polarity. Improperly inserted batteries can damage the product, causing the battery to short-circuit or leak.
- Before inserting, check that the batteries are not damaged, deformed or inflated. Using damaged batteries in any way poses a risk of fire, explosion or serious injury.
- After inserting or replacing the batteries, check that the battery compartment cover is not damaged, that it is properly closed to prevent the batteries from falling out. If the battery compartment cover is damaged, cracked or missing, do not use the product and have it repaired.
- Do not use the product with discharged batteries. Replace discharged batteries with new ones. This will prevent possible damage to the product or leakage of the batteries.
- Wash your hands before and after replacing the batteries. You will prevent the transfer of dirt.
- If you do not use the product for an extended period of time, remove the batteries to prevent them from leaking and damaging the product.
- Store the batteries and the product with the batteries in a dry, cool and well ventilated place. The recommended storage temperature is 5 to 45 °C. Do not store batteries or the product with batteries in wet or dusty environments, in extreme temperatures, or in environments where toxic, chemical, or explosive substances are stored or used.
- Do not expose the battery or product with the batteries to direct sunlight.
- Do not throw batteries into a fire or use open flames near them, e.g. candles. The battery may explode when exposed to high temperatures.
- Do not submerge the batteries in water or in any other liquid. Do not place any containers filled with water, e.g. a vase on the batteries.
- Do not expose batteries to mechanical damage, disassemble or deform them. There is a risk of electrolyte leakage, explosion and serious injury due to chemical burns.

- Do not short-circuit the battery. Do not leave the batteries loose, e.g. in a drawer, with metal items (paper clips, coins, keys, etc.). There is a risk of short-circuiting.
- Do not attempt to recharge batteries that are not intended to be rechargeable. There is a risk of explosion and serious injury due to chemical burns.
- Batteries contain environmentally damaging compounds and therefore do not belong in standard municipal waste. Take used batteries for proper disposal at a designated battery collection point.
- In the event of a battery leak, do not touch the leaked electrolyte with your bare hands. Use protective aids (protective gloves, goggles or a respirator). We recommend opening windows or doors to ensure adequate ventilation of the space. When skin is affected, rinse the affected area with clean cold water; rinse the affected eyes with plenty of clean water and seek medical help; when swallowed, immediately contact emergency medical help, rinse mouth, but do not induce vomiting.



Read this user's manual carefully prior to installing or operating your new appliance. Make sure to keep it for future reference.



Read the technical documentation.



Read the user's manual.



Fire hazard

The appliance contains a flammable refrigerant. It is necessary to adhere to safety instructions.

SERVICE MANUAL

- The service manual is intended only for a qualified person who is authorized to handle flammable refrigerants.

1.1 Checking the area

Before starting work on a system containing flammable refrigerants, safety checks are necessary to ensure that the risk of ignition is minimized. When repairing the cooling system, the following precautions must be taken before carrying out work on it.

1.2 Working procedure

The work must be carried out in a controlled manner so as to minimize the risk of flammable gases or vapours being present when the work is carried out.

1.3 Overall working space

All maintenance personnel and other on-site workers must be instructed about the nature of the work being done. Work in confined spaces must be avoided. The area around the workplace must be divided into sections. It must be ensured that the conditions inside the space are safe by carrying out a check of flammable materials.

1.4 Checking the presence of refrigerant

The space must be inspected by an appropriate refrigerant detector before and during operation to ensure technicians are aware of potentially flammable atmospheres. It must be ensured that the leakage detection equipment used is suitable for use on flammable refrigerants, i.e. non-sparking, adequately sealed or intrinsically safe.

1.5 Presence of fire extinguisher

If any hot work is to be carried out on the refrigeration equipment or associated parts, suitable fire extinguishing equipment must be at hand. The fire extinguisher must be powder or CO₂ in the vicinity of the filling area.

1.6 No ignition sources

No person carrying out work on a refrigeration system involving the stripping of any pipework containing or having contained flammable refrigerant shall use any sources of ignition in such a way as to result in a risk of fire or explosion. All possible ignition sources, including cigarette smoking, should be kept sufficiently away from the installation, repair, removal and disposal sites during which the flammable refrigerant may eventually be discharged into the surrounding area. Before work is carried out, the area around the equipment must be inspected to ensure that there are no burning or ignition hazards. "No smoking" signs must be displayed.

1.7 Ventilated Space

It must be ensured that the space is open or adequately ventilated before the system is disrupted or hot work is carried out. The ventilation intensity must last for the duration of the work. Ventilation should safely disperse any discharged refrigerant and preferentially take it out into the atmosphere.

1.8 Checks of refrigerating equipment

Where electrical components are changed, the components shall be suitable for this purpose and comply with the correct specification. Always follow the manufacturer's instructions for maintenance and service. If doubts arise, the technical department of the manufacturer must be consulted for assistance.

For installations containing flammable refrigerants, the following checks must be carried out:

- the size of the refill is consistent with the size of the room in which the refrigerant-containing parts are installed;
- ventilation units and outlets work at full capacity and are not clogged;
- if an indirect refrigerant circuit is used, the second circuit must be checked for the presence of refrigerant;
- the marking of the device must always be visible and legible; markings and marks that are not legible must be repaired;
- cooling pipes or components are installed in places where they are unlikely to be exposed to any substances that may corrode the components containing the refrigerant, unless these components are constructed of materials that are internally resistant to corrosion or are suitably protected against corrosion.

1.9 Electrical Instrument Inspection

Repairs and maintenance of electrical components must include safety checks and inspection of components.

If a fault occurs that could compromise safety, then no electrical power must be connected to the circuit until the fault is satisfactorily resolved.

If the malfunction cannot be corrected immediately but work must be continued, an appropriate temporary solution must be used. This must be communicated to the owner of the device so that all parties are aware of it.

Initial security checks must ensure:

- that the capacitors are discharged: this must be done in a safe manner to avoid the possibility of sparks;
- that no electrical components and lines are exposed during filling, refreshing and cleaning of the system;
- that the grounding is not broken.

2. Servicing of sealed components

During repairs of sealed components, all electrical power must be disconnected from the equipment being worked on before the sealed lids are removed, etc. If it is absolutely necessary to have electrical power at the equipment during service, then a permanently operating leak detection device must be placed at the most critical point to warn of a potentially hazardous situation.

Particular care must be taken to ensure that work on electrical components has not altered the enclosure to such an extent as to affect the level of protection. This must include damage to cables, excessive number of connections and terminals not made according to the original specification, damage to seals, improper implementation of seals, etc.

It must be ensured that the appliance is mounted securely.

It must be ensured that the gaskets or sealing materials are not deteriorated so that they no longer serve the purpose of preventing the ingress of flammable environments. Replacement parts must be in accordance with the manufacturer's specifications.



Note:

The use of a silicone seal may inhibit the effectiveness of some types of leak detection devices. Internally safe components do not need to be disconnected before they can be worked on.

3. Service of intrinsically safe components

No permanent inductive or capacitive load shall be applied to the circuit without ensuring that the permissible voltage and current permitted for the equipment in use are not exceeded.

Internally safe components are the only types that can be worked on in a flammable environment, even if they are alive. The test apparatus must be correctly dimensioned.

Parts are replaced only by parts specified by the manufacturer. Other parts may result in ignition of the refrigerant during leakage into the environment.

4. Cabling

It shall be checked that the wiring is not exposed to wear, corrosion, excessive pressure, vibration, sharp edges or any other adverse effects of the environment. The check must also take into account the effects of ageing or permanent vibrations from sources such as compressors or fans.

5. Use of flammable coolant

Under no circumstances should potential sources of ignition be used to search for or detect refrigerant leaks.

The halogen burner (or any other detector using an open flame) shall not be used.

6. Leak detection methods

The following leak detection methods are considered acceptable for systems containing flammable refrigerants.

Electronic leak detectors must be used to detect flammable refrigerants, but their sensitivity may not be adequate or may require recalibration. (The detection device must be calibrated in a refrigerant-free compartment.) It must be ensured that the detector acquires a potential source of ignition and that it is suitable for the refrigerant used. The leak detection device must be set to a percentage of refrigerant LFL and must be calibrated to the refrigerant used and the appropriate percentage of gas confirmed (maximum 25%).

Leak detection fluids are suitable for use with most refrigerants, but the use of chlorine-containing detergents must be excluded as chlorine may react with the refrigerant and corrode copper piping.

If leakage is suspected, all open fires must be removed/extinguished.

If a refrigerant leakage is found, which requires brazing, all refrigerant must be removed from the system or separated (by closing the valves) in the part of the system away from the leakage. The system must then be purified with oxygen-free nitrogen (OFN), both before and after the brazing process.

7. Removal and draining

Conventional procedures must be used when the cooling circuit is disrupted for repairs – or for any other reason. However, it is important to stick to the best method because of the flammability. The following procedure must be followed:

- remove refrigerant;

- clean the circuit with inert gas;
- drain;
- clean again with inert gas;
- open the circuit by cutting or brazing.

The circuit filling must be removed to the correct sampling cylinders. The system must be "flooded" with OFN (oxygen-free nitrogen) to make the unit safe. The procedure may need to be repeated several times. Compressed air or oxygen must not be used for this task.

Flooding can be achieved by disrupting the vacuum in the system with using OFN and continuing filling until the operating pressure is reached, then venting into the air and finally reducing to a vacuum. This process must be repeated as long as the refrigerant is in the system. When the last refill of OFN is used, the system must be vented to atmospheric pressure to allow the work to be carried out. This operation is absolutely necessary if brazing is to be carried out on the pipeline.

It must be ensured that the outlets for the pump are not close to any source of ignition and that ventilation is provided.

8. Filling procedure

In addition to conventional filling procedures, the following requirements must be observed.

- It must be ensured that there is no contamination by various refrigerants when using the filling device. Hoses or pipes must be as short as possible to minimize the amount of refrigerant contained in them.
- The cylinders must be held vertically.
- Ensure that the cooling system is earthed before filling the system with refrigerant.
- When filling is complete, the system must be labelled (if it is not already).
- Extreme care must be taken not to overfill the cooling system.

Before refilling the system, it must be pressure tested with OFN. The system must be tested for leakage after filling but before commissioning. A verification test must be carried out before leaving the assembly site.

9. Decommissioning

Before performing this procedure, it is essential that the technician is fully acquainted with the equipment and all its details. Sufficient practice is recommended to remove all refrigerant safely. Oil and refrigerant samples must be taken if analysis is required before the regenerated refrigerant can be reused. It is essential that electricity is available before starting this activity.

- Familiarization with the equipment and its operation.
- Electrical disconnection of the system.
- Before starting the procedure, ensure that:
 - a mechanical device for handling the refrigerant cylinders is available, if required;
 - all personal protective equipment was available and used correctly;
 - the decommissioning procedure was constantly supervised by a competent person;
 - the sampling device and the cylinders comply with the relevant standards.
- Drain the cooling system if possible.
- If it is not possible to achieve a vacuum, a collection pipe is made so that the refrigerant can be taken from the different parts of the system.
- Ensure that the cylinder is placed on the scales before the sampling takes place.
- The sampling device is switched on and the work is carried out according to the manufacturer's instructions.
- The cylinders will not overfill. (No more than 80% of the liquid content of the cartridge.)
- The maximum working pressure of the cylinder shall not be exceeded, even temporarily.
- When the cylinders are properly filled and the procedure is completed, ensure that the cylinders and equipment are immediately removed from the installation site and all isolation valves on the equipment are closed.
- The removed refrigerant must not be filled into another refrigeration system until it has been cleaned and inspected.

10. Label precautions

- The device must be provided with a label stating that it has been decommissioned and is free of refrigerant. The label must be dated and signed. Ensure that the equipment bears labels indicating that the equipment contains a flammable refrigerant.

11. Removing

- When the refrigerant is removed from the system, either for service or for decommissioning, correct practice is recommended that all refrigerants are removed safely.
- When transferring the refrigerant to the cylinders, it must be ensured that only appropriate cylinders are used to remove the refrigerant.
- It must be ensured that the correct number of cylinders is available to accommodate the total system load. All cylinders to be used must be designed for the refrigerant to be removed and marked with a label for this refrigerant (i.e. special cylinders for refrigerant removal). The cylinders must be complete with safety valve and associated shut-off valves in good operating condition. Empty sampling cylinders are drained and cooled down if possible prior to collection.
- Sampling devices must be in good working order with a set of instructions related to the devices that are at hand and must be suitable for removing flammable refrigerants. In addition, a set of calibrated scales in good operating condition must be available. The hose must be complete with detachable couplings without leakage and in good condition. Before using the sampling device, it shall be checked that it is in satisfactory operating condition, has been properly maintained and that all associated electrical components are sealed to prevent ignition in the event of refrigerant discharge. If in any doubt, the manufacturer shall be consulted.
- The collected refrigerant must be returned to the refrigerant supplier in the correct collection cylinder and with the appropriate agreed waste transfer letter. Refrigerants are not mixed in the sampling units, and especially not in the cylinders.
- If compressors or compressor oils are to be removed, ensure that they have been drained to an acceptable level to ensure that no flammable refrigerant remains in the lubricant. The draining procedure must be carried out before the compressor is returned to the supplier. Only electric heating of the compressor body must be used to speed up this process. When oil is drained from the system, it must be safely removed.

SPECIFIC INFORMATION FOR APPLIANCES USING REFRIGERANT GAS R290

- Carefully study all the warnings.
- For defrosting and cleaning, do not use any other tools than those recommended by the manufacturer.
- The appliance must be stored in a room where there are no sources of ignition (e.g. open flame, gas appliance in operation, electrical heating equipment in operation) in continuous operation.
- Do not puncture or burn the cooling circuit.
- It is necessary to take into consideration that refrigerants may be odourless.
- The appliance must be installed, operated and stored in a room with a floor area greater than 3 m².
- This appliance contains 56 g of refrigerant gas R290.
- R290 is a refrigerant gas that meets European environmental protection directives. Do not drill into or damage any part of the cooling circuit.
- Sufficient ventilation must be provided in the room where this appliance is installed operated or stored. Otherwise, there is a risk of an explosion or fire in the event that leaked refrigerant ignites, e.g. when a gas cooker is turned on, etc.
- The appliance must be stored in such a manner that its mechanical damage is prevented.
- Persons working with or repairing cooling circuits must have appropriate authorisation issued by an authorised institution that certifies this person's competence to work with refrigerants in accordance with the specific assessment of the association for this sector.
- Maintenance tasks must be performed solely on the basis of the recommendations of this appliance's manufacturer. Maintenance and repair tasks that required the contribution of other qualified expert personnel may only be performed under the supervision of specialised experts in the flammable refrigerants sector.
- Check the rating label for the type of refrigerant gas used in your appliance.
- Do not cover the vents.
- Adhere to national codes relating to gas.

EXPLANATION OF SYMBOLS PLACED ON THE PRODUCT OR IN THE ACCOMPANYING DOCUMENTATION



The product meets all the basic requirements of the applicable EU directives.



This symbol on products or accompanying documents means that used electric or electronic products must not be added to ordinary municipal waste.



This symbol on the accumulator or battery means that the used battery must not be added to normal municipal waste.

EN Spot Air Conditioner

User Manual

- Thank you for purchasing our SENCOR product; we hope it will serve to your satisfaction.
- Prior to using this appliance, please read the user manual thoroughly, even in cases when you are already familiar with the use of similar types of appliances. Use the appliance only as described in this user manual. Keep the manual for future reference. If you pass the appliance on to another person, ensure that this user manual is included.
- Carefully unpack the appliance and make sure not to discard any part of the packaging material until you have removed all its components. It is recommended that you keep the original packaging, packing material, receipt and confirmation of the extent of the seller's liability or warranty certificate at least for the duration of the legal right to file a defect claim or the quality warranty. When transporting the appliance, we recommend repackaging it in the original box provided by the manufacturer.









DESCRIPTION OF THE APPLIANCE

A1 Control panel	A6 Power cable
A2 Cold air outflow	A7 Water tank
A3 Castors	A8 Water level indicator
A4 Side warm air inlet protective grille	A9 Side cold air inlet protective grille
A5 Warm air outflow	









DESCRIPTION OF ACCESSORIES



B1 Flexible air exhaust hose	B3 Adapter for window connection
B2 Adapter for connection to the air outlet	B4 Remote control

DESCRIPTION OF THE CONTROL PANEL







C1  button	C6  button
C2  button	C7  button
C3  button	C8  button
C4  button	C9  button
C5 Display	C10 Operation indicators

Operation indicators

	Empty water tank indicator light
	Full water tank indicator light
	Automatic defrost indicator light
	Timer on indicator light
	Sleep mode indicator light
	Indicator light for oscillation function on
	High fan speed indicator light
	Medium fan speed indicator light
	Low fan speed indicator light

	Cooling mode indicator light
	Humidification mode indicator light
	Fan mode indicator light

REMOTE CONTROL

- | | |
|---|--|
| D1  button | D5  button for switching on/off |
| D2  button to set the timer | D6  button to switch the sleep mode on/off |
| D3  button to switch oscillation on/off | D7  button to select the operating mode |
| D4 Buttons to set the fan speed | |

Purpose of Use

- The Sencor SAC ST0180C spot air conditioner is designed to cool the air in the place where the spot air conditioner is located. The spot air conditioner can be used both without the need to connect a flexible air exhaust hose and with a connected flexible hose (which is included in the delivery).
- Spot air conditioner is not designed to cool the entire room.

INSTALLATION

Installation Location for the Spot Air Conditioner

- Remove the spot air conditioner from the packaging and make sure that you have removed all parts and accessories.
- Locate the spot air conditioner on an even, dry and stable surface and within reach of a grounded power socket. Do not place it on an unstable or inclined surface from which the spot air conditioner could slide, fall, become damaged or lead to injury.
- The spot air conditioner must be located in such a way that it is not exposed to direct sunlight.
- Check that there are no heat sources (e.g. heating, mobile heaters, stoves, etc.) in the vicinity of the place where the spot air conditioner will be located.
- The spot air conditioner is equipped with castors that facilitate handling. Do not use the castors if you need to move the air conditioner on a carpet or similar surface. Avoid running over objects.
- For optimum efficiency, maintain a minimum distance of 50 cm from walls or other obstacles.
- Place the spot air conditioner at a sufficient distance from curtains, drapes or blinds.
- Make sure that the drain hose does not touch any objects.



Note:

Do not use the spot air conditioner to cool a room with computer servers, etc. Installation, adjustment, maintenance and repair must only be carried out by a qualified person.

Installation of Castors

- The spot air conditioner can be used both without and with the castors. If you need to install the castors, do the following:
 1. Carefully tilt the spot air conditioner.
 2. Insert the castors into the holes at the bottom of the spot air conditioner – see Figure E.
- If you need to remove the castors, remove them from the bottom of the spot air conditioner.

Pump Hose

- Before assembling the water tank, insert the water hose into the designated hole in the water tank cover (see arrow in Figure F). Make sure that the water tank does not clamp or push the hose, then release it and gently insert the water tank into the body of the spot air conditioner.

Water tank

- **In the cooling mode, the water tank must be filled with clean, cold water. On the contrary, in the dehumidification mode, it is necessary for the water tank to be empty.**

- **Filling the water tank:** while the spot air conditioner is off, pull out the water tank and pour clean cold water into it up to the maximum level. Insert the tank back into the spot air conditioner body.

- If the  indicator light comes on during the operation of the spot air conditioner and the operation of the spot air conditioner is interrupted after a while, it will be necessary to replenish the water. We recommend waiting approximately 3 minutes before ejecting the reservoir and replenishing the water, otherwise residual water could drip on the floor. After inserting the tank into the body of the spot air conditioner, its operation will be restored.

- **Emptying the tank:** fully pull the tank out of the spot air conditioner body. Pour out the remaining water from the tank and put it back into the spot air conditioning body.

- If the  indicator light comes on during operation and the operation of the spot air conditioner is interrupted after a while, it will be necessary to pour out the water. Pull out the tank completely and dispose of the water in the waste. Then, reinsert it. After inserting the tank into the body of the spot air conditioner, its operation will be restored.

Installation of the Flexible Hose for the Spot Air Conditioner (optional)

- If you decide to use a spot air conditioner with a flexible hose, proceed as follows for installation:

1. Remove the window adapter from the flexible hose and assemble the parts **a** and **b** together – see Figure **G1**. This will assemble the adapter for connection to the window.
2. Install the adapter (**B2**) for the air outlet opening by first inserting the lower part of the adapter, and then press the upper part until you hear a click – see figure **G2**.
3. Stretch the flexible hose to the required length.
4. Attach the adapter for connection to the outlet to one end of the flexible hose.
5. Attach the free end of the flexible hose to the adapter (**B2**) and screw it in counter-clockwise.
6. Attach the adapter to the window as shown in Figure **G3** so that you can use the spot air conditioner.



COMMISSIONING

- Make sure it is assembled correctly.
- Make sure that the spot air conditioner is located in a suitable place at sufficient distance from the socket.
- Insert the power plug into a properly grounded power socket.
- The spot air conditioner will switch to the stand-by mode.

CONTROLS OF THE SPOT AIR CONDITIONER

A. CONTROL PANEL

Switching the Spot Air Conditioner On/Off

- Press the  button briefly and the spot air conditioner will switch on and start by default.
- Press the  button again to switch the spot air conditioner off and into standby mode. To switch off completely, disconnect the plug from the power socket.



Warning:

Do not turn on the spot air conditioner immediately after it is turned off. Wait a few minutes before switching on again. Otherwise, the compressor could be damaged.









Note:





Never switch off the spot air conditioner by unplugging the power cord from the mains socket. Turn off the spot air conditioner with the  button, wait several minutes and then disconnect the power cord.

OPERATING MODES





1. Cooling Mode

- Refill the water tank. Follow the instructions in the WATER TANK section.
- Press the  button repeatedly until the  indicator lights up on the display.
- Use the  buttons to set the desired temperature. You can set the temperature in the range from 16 to 30 °C.
- Press the  button to adjust the fan speed. Press the  button repeatedly to switch the speed in the following order: high speed – medium speed – low speed. Each time the button is pressed, the respective indicator will also be lit on the control panel.
- Press the  button to switch on the oscillation of the air outlet lamellae.

2. Dehumidifier Mode

- Press the  button repeatedly until the  indicator lights up on the control panel.
- The humidity in the room is reduced in this mode. Condensed moisture accumulates in the reservoir. As soon as the tank is full, the  indicator light will turn on. Empty the tank according to the instructions in the section WATER TANK.
- Use the  buttons to set the target humidity. You can set the humidity in the range from 30 to 90 %.

3. Fan Mode



- Press the  button repeatedly until the  indicator lights up on the control panel.
- In this mode, the fan will circulate the air in the room, but will not cool it.
- Press the  button to adjust the fan speed. Press the  button repeatedly to switch the speed in the following order: high speed – medium speed – low speed. Each time the button is pressed, the respective indicator will also be lit on the control panel.
- Press the  button to switch on the air outlet lamellae.

SPOT AIR CONDITIONER FUNCTION



1. Timer Functions

- The spot air conditioner allows you to set two different timers – the on timer and the off timer of the spot air conditioner.

a) Timer for Turning On the Spot Air Conditioner

- The timer for turning on the spot air conditioner allows you to activate it after a set period.
- While the spot air conditioner is in standby mode, press the  button. The numeric display will start blinking, and the timer indicator lights up.
- Use the  buttons to set the time after which the air conditioner should turn on. The time can be set in a range from 1 to 24 hours, in 1-hour increments.
- Wait approximately 5 seconds for the time to be saved in memory. The countdown for the set time will then begin automatically.
- Once the set time has elapsed, the air conditioner will start in the last operating mode.

b) Timer for Turning Off the Spot Air Conditioner

- The timer for turning off the spot air conditioner allows you to turn it off after a set period.
- While the spot air conditioner is running, press the  button. The numeric display will start blinking, and the timer indicator lights up.
- Use the  /  buttons to set the time after which the air conditioner should turn off. The time can be set in a range from 1 to 24 hours, in 1-hour increments.
- Wait approximately 5 seconds for the time to be saved in memory. The countdown for the set time will then begin automatically.
- Once the set time has elapsed, the air conditioner will turn off and switch to standby mode.

2. Sleep Timer

- The sleep timer is used to reduce energy consumption during the night when a constant temperature is not required. The function also ensures comfort during sleep, as the operation of the air conditioner is muted and the display light is dimmed.
- Select the cooling mode and set the default temperature. Then press the  button to turn on the sleep function.
- The fan speed is automatically set to low.

Switching the lamellae movement on/off

- Press the  button to activate / deactivate the lamellae movement.

B. REMOTE CONTROL

Inserting and Replacing Batteries

- Slide out the battery compartment cover, which is located on the bottom side of the remote control. Insert the 1x CR2032 button cell battery into the compartment and slide the cover into place.
- When inserting the batteries ensure the correct polarity as shown in the battery compartment.



Note:



Taking the batteries out of the remote control will delete all the settings. After new batteries are inserted the default remote control setting as programmed by the manufacturer will be renewed.

- If you will not be using the remote control for longer than 2 months, remove the batteries.

Using the remote control

- For the remote control to work properly, make sure that the maximum distance between the control and the spot air conditioner does not exceed 8 m and that there is no obstacle between the control and the spot air conditioner that could prevent signal transmission.
- Point the remote control directly at the spot air conditioner. The signal transmission is confirmed by a short sound signal.
- Do not expose the remote control to direct sunlight or high temperatures. Otherwise the signal may not be transmitted.

Switching the Spot Air Conditioner On/Off

- Press the  button briefly and the spot air conditioner will switch on and start by default.
- Press the  button again to switch the portable air conditioner off and into standby mode. To switch off completely, disconnect the plug from the power socket.



Warning:





Do not turn on the spot air conditioner immediately after it is turned off. Wait a few minutes before switching on again. Otherwise, the compressor could be damaged.







Note:

Never switch off the spot air conditioner by unplugging the power cord from the mains socket. Turn off the spot air conditioner with the  button, wait several minutes and then disconnect the power cord.



1. Cooling Mode

- Refill the water tank. Follow the instructions in the WATER TANK section.
- Press the  button repeatedly until the  indicator lights up on the display.
- Use the  /  buttons to set the desired temperature. You can set the temperature in the range from 16 to 30 °C.
- Press the buttons to adjust the fan speed. The speed is switched in the following order: high speed – medium speed – low speed. Each time the button is pressed, the respective indicator will also be lit on the control panel.
- Press the  button to switch on the air outlet lamellae.

2. Dehumidifier Mode

- Press the  button repeatedly until the  indicator lights up on the control panel.
- The humidity in the room is reduced in this mode. Condensed moisture accumulates in the reservoir. As soon as the tank is full, the  indicator light will turn on. Empty the tank according to the instructions in the section WATER TANK.
- Use the  /  buttons to set the target humidity. You can set the humidity in the range from 30 to 90 %.
- In this mode it is not possible to set the temperature or the speed of the fan. The fan speed is automatically set to low speed.

3. Fan Mode



- Press the  button repeatedly until the  indicator lights up on the control panel.
- In this mode, the fan will circulate the air in the room, but will not cool it.
- Press the buttons to adjust the fan speed. The speed is switched in the following order: high speed – medium speed – low speed. Each time the button is pressed, the respective indicator will also be lit on the control panel.

SPOT AIR CONDITIONER FUNCTION



1. Timer Functions



- The spot air conditioner allows you to set two different timers – the on timer and the off timer of the spot air conditioner.

a) Timer for Turning On the Spot Air Conditioner

- The timer for turning on the spot air conditioner allows you to activate it after a set period.
- While the spot air conditioner is in standby mode, press the  button. The numeric display will start blinking, and the timer indicator lights up.
- Use the  /  buttons to set the time after which the air conditioner should turn on. The time can be set in a range from 1 to 24 hours, in 1-hour increments.
- Wait approximately 5 seconds for the time to be saved in memory. The countdown for the set time will then begin automatically.
- Once the set time has elapsed, the air conditioner will start in the last operating mode.

b) Timer for Turning Off the Spot Air Conditioner



- The timer for turning off the spot air conditioner allows you to turn it off after a set period.
- While the spot air conditioner is running, press the  button. The numeric display will start blinking, and the timer indicator lights up.
- Use the  /  buttons to set the time after which the air conditioner should turn off. The time can be set in a range from 1 to 24 hours, in 1-hour increments.
- Wait approximately 5 seconds for the time to be saved in memory. The countdown for the set time will then begin automatically.
- Once the set time has elapsed, the air conditioner will turn off and switch to standby mode.

- If you need to cancel the timer, press the  button and use the  /  buttons to set the timer value to "00".

c) Sleep function

- The sleep timer is used to reduce energy consumption during the night when a constant temperature is not required. The function also ensures comfort during sleep, as the operation of the air conditioner is muted and the display light is dimmed.
- Select the cooling mode and set the default temperature. Then press the  button to turn on the sleep function.
- The fan speed is automatically set to low.

Automatic defrosting

- At low room temperature, frost may accumulate on the evaporator during operation. In this case, the spot air conditioner will automatically start defrosting and the  indicator will start flashing.
- The operation of the compressor stops, however, the fan will continue to run.
- After approximately 10 minutes of operation in defrost mode, the  indicator light goes out and compressor operation resumes.



Note:

We recommend letting the spot air conditioner complete the automatic defrosting and not turning it off during this time.

Protection of the Compressor

- The compressor is equipped with a time protection against damage when switching on again for a period of 3 minutes. If the spot air conditioner is switched on shortly after it is switched off, the operation of the compressor will start only after 3 minutes.

TIPS FOR PROPER USE

- To ensure that the spot air conditioner works correctly, we recommend that you stick to the following:
 - Close all windows and doors of the room where the spot air conditioner is used. If you have installed the spot air conditioner in a room only temporarily, you can leave the door slightly ajar (about 1 cm) to ensure proper ventilation.
 - Prevent direct sunlight from entering the room. Close the curtains or blinds to ensure economical operation of the air conditioner.
 - Do not block the air outlet and inlet openings.
 - Check that there is no heat source turned on in the room.
 - Never use the spot air conditioner in an excessively humid environment, such as in laundries.
 - Never use the spot air conditioner outdoors.
 - Check that the spot air conditioner is located on a flat surface. If necessary, install special brakes on the castors.

MAINTENANCE AND CLEANING

- Before cleaning, turn off the spot air conditioner, wait several minutes and then disconnect the power cord from the mains socket.



Warning:

Do not use abrasive cleaning agents, solvents, etc. to clean any parts of the appliance, as these could damage the surface.



Warning:

To prevent the risk of electric shock, do not immerse the appliance, power cable, or plug into water or any other liquid.

Cleaning the Protective Grilles and Air Filters

- When using the spot air conditioner regularly, clean the protective grilles and air filters at least once every two weeks to prevent dust from clogging the fan.

- Carefully remove the protective grilles and remove the filters – see Figure 1. Use a vacuum cleaner to remove dust from the grilles and filters.
- In case of heavy soiling, wash the filter by hand in a solution of lukewarm water (max. 40°C) and neutral detergent. Then thoroughly rinse under flowing water and allow to dry naturally. Do not dry it in a clothes dryer or in direct sunlight. Once the filters are dry, you can install them back in their place.
- In case of heavier soiling, you can wipe the protective grilles with a slightly damp cloth and then wipe them dry with a clean cloth.



Note:

Do not use spot air conditioning without properly installed air filters and protective grilles. Never install wet or damp air filters and protective grilles in spot air conditioners.

Cleaning the water tank

- Remove the water tank completely from the spot air conditioner body.
- Pour out the remaining water and dry the inside of the container with a dry cloth, or allow it to dry freely.
- Place the dry tank back into the spot air conditioner body.



Note:

If you use the spot air conditioner irregularly, we recommend emptying the container after each use or at least every third day to prevent the formation of unwanted microorganisms and unpleasant odours.

Cleaning the outer casing

- To clean the outer case, use a soft wiping cloth dipped in a solution of lukewarm water and neutral detergent. Then wipe the surface dry.
- When cleaning, do not spray water or any other liquid on the spot air conditioner, do not water it or submerge it in water or in any other liquid.
- Do not use abrasive cleaning products, solvents, petrol, etc. for cleaning.

Spot Air Conditioner Storage

- Keep the spot air conditioner running in a heated room in fan mode for about 12 hours to dry it out and prevent mould.
- Disconnect the flexible hose (if it was installed) and store it in a safe place out of the reach of children.
- Empty and clean the water tank according to the above instructions.
- Clean the air filters and reattach them. Wipe the outer case of the spot air conditioner. Remove the batteries from the remote control.
- Store the air conditioner in a cold, dry and dark location.

Recommissioning

- Make sure that the power cord and plug are not damaged and the air filters are clean. Insert new batteries in the remote control. Follow the instructions in the "Inserting and Replacing Batteries" section. Install the spot air conditioner according to the guidelines provided in the previous section of the manual, "Installation".

ERROR MESSAGES

Display	Meaning	Solution
E1	Electrical short circuit both on the temperature sensor and on the base plate.	Contact an authorised service centre.
E2	Temperature sensor copper tube and printed circuit board wiring (coil) electrical short circuit	
E4	Condensate reservoir is full.	Empty the water tank.
E8	The spot air conditioner is bent.	Place the spot air conditioner in an upright position.
H1	In the dehumidification mode, the ambient humidity is higher than 90%.	This is normal. In very high ambient humidity (above 90%), the spot air conditioner will not work. Wait until the humidity drops naturally, or move the spot air conditioner to another place with lower humidity.



Note:

If any of the above malfunctions occur, turn off the spot air conditioner and check the cause of the malfunction. Turn it on again, and if this fault occurs again, turn it off, disconnect the power cord from the power socket and contact the manufacturer, an authorised service centre or a person with appropriate qualifications and entrust them with the repair of the fault.

TECHNICAL SPECIFICATIONS

Power supply	220–240 V~ / 50 Hz
Cooling power output	1800 BTU/hour
Cooling power consumption	200 W
Current consumption	0.9 A
EER cooling factor	2.6
Dehumidification capacity	15 l/day
Capacity of the built-in condensate reservoir	3 l
Coolant type and weight	R290 / 56 g
Air flow volume	120 m ³ /hour
Sound pressure level	45–58 dB (A) (high-low)
Sound power level	38–44 dB (A) (high-low)
Maximum permissible value of operating pressure	4.0 MPa
Dimensions of the spot air conditioner (W × D × H)	215 × 343 × 590 mm
Weight	12.8 kg
Operating temperature (cooling)	16 to 30 °C

The declared noise emission value of the appliance is 45–58 dB (A), which is the A sound pressure level relative to a reference sound power of 1 pW.



Note:

The efficiency of the spot air conditioner may be reduced if it is used outside the range of operating temperatures listed above.

DISPOSAL OF USED BATTERIES

Batteries contain environmentally damaging compounds and therefore do not belong in standard municipal waste. Take used batteries for proper disposal at a designated battery collection point.

INSTRUCTIONS AND INFORMATION ON DISPOSAL OF USED PACKAGING MATERIAL

Dispose of used packaging material at the designated municipal waste disposal site.

DISPOSAL OF USED ELECTRICAL AND ELECTRONIC EQUIPMENT

Used electrical and electronic products must not be disposed of in ordinary municipal waste. To enable the proper disposal, renewal and recycling of these products, deliver them to the designated collection points. Alternatively, in some European Union states or other European countries the products can be returned to the local retailer when buying an equivalent new product. By disposing of this product correctly, you help to conserve valuable natural resources and prevent any potential adverse impact on the environment and human health that could result from improper waste disposal. For more details, contact your local authority or nearest collection point. Fines may be imposed for the improper disposal of this type of waste as per national regulations.

For business entities in European Union States

If you wish to dispose of electrical and electronic equipment, please request the necessary information from your retailer or supplier.

Disposal in other countries outside the European Union

To dispose of this product elsewhere, request the necessary information on the correct disposal method from local authorities or your retailer.

Changes to text and technical parameters are reserved.



FAST ČR, a.s.
U Sanitasu 1621
CZ-25101 Říčany
www.sencor.com
info@sencor.cz