



# Installation & Operation Manual

## Commercial Back Bar

- Remote & Self-Contained Standard height and low height Models BBR, BBS, BBRLP & BBSLP Series
- Remote & Self-Contained Narrow Door Models BBRN & BBRSN Series
- Remote & Self-Contained Pass Thru Models PTR & PTS Series
- Remote & Self-Contained Sliding Door Models SDB & SDP Series
- Self-Contained Dual-Zone DZS Series Concessionaire
- Direct Draw DDC & DDS Series



Model BBSLP108 Shown



eco friendly  
R290 Hydrocarbon  
Refrigerant

The Perlick Corporation verifies this product **does not contain a prohibited refrigerant** as defined by the California Air Resource Board (CARB), the state of New York, and any other state with HFC prohibition laws. This product does not contain HFC's. The following disclosure statement is provided to comply with the CARB regulation:

This equipment is prohibited from use in California with any refrigerants on the "List Of Prohibited Substances" for that specific end use, in accordance with the California Code of Regulations, title 17, section 95374. This disclosure statement has been reviewed and approved by the Perlick Corporation and the Perlick Corporation attests under penalty of perjury, that these statements are true and accurate.

Form No. Z2604  
Rev A 04.20.23

# TABLE OF CONTENTS

General Information..... 2

Safety ..... 2

Prior To Installation ..... 3

Installation ..... 4

Operation..... 5

Adjustments..... 7

Maintenance ..... 11

Troubleshooting..... 14

Dimensions..... 16

Wiring Diagrams ..... 34

Warranty ..... 48

## GENERAL INFORMATION

### Introduction

Congratulations on your purchase of a Perlick commercial back bar product. This manual has been prepared to assist you in the installation of your cabinet and to acquaint you with its operation and maintenance.

We dedicate considerable time to ensure that our products provide the highest level of customer satisfaction. If service is required, your dealer can provide you with a list of qualified service agents. For your own protection, never return merchandise for credit without our approval.

We thank you for selecting a Perlick product and assure you of our continuing interest in your satisfaction.

### Warranty

To register your product, visit our web site at [www.perlick.com](http://www.perlick.com). Click on “Commercial”, then “Service”. Click on the link “Warranty Registration Form”. You must complete and submit this form or the installation date will revert back to the ship date.

Please record the purchase date and the dealer’s name, address and telephone number below.

Model Number: \_\_\_\_\_

Serial Number: \_\_\_\_\_

Purchase Date: \_\_\_\_\_

Dealer Name & Address

\_\_\_\_\_

\_\_\_\_\_

Phone Number \_\_\_\_\_

## SAFETY

PLEASE READ all instructions completely before attempting to install or operate the unit. Take particular note of the DANGER, WARNING and CAUTION information in the manual. The information is important for the safe and efficient installation, operation and care of your Perlick unit.

**DANGER** Indicates a hazard that **WILL** result in serious injury or death if precautions are not followed.

**WARNING** Indicates a hazard **MAY** cause serious injury or death if precautions are not followed.

**CAUTION** Indicates a hazard where minor or moderate injury may occur if precautions are not followed.

**NOTICE** Indicates that property damage may occur if warnings or instructions are not followed.

**IMPORTANT!**

Read and understand all information in this manual before attempting the installation. All plumbing and electrical work must be performed by a qualified technician and conform to all applicable state and local codes.

**WARNING: California Prop 65 Notice**

These products may expose you to chemicals including Chromium, which are known to the state of California to cause cancer and birth defects or other reproductive harm. For more information on whether a product in this list contains these chemicals, please refer to the specific product page at [perlick.com](http://perlick.com). Or to find out more about Prop 65, go to [P65Warnings.ca.gov](http://P65Warnings.ca.gov).



## PRIOR TO INSTALLATION

### Uncrating and Inspection

Remove all crating material. Carefully inspect cabinet for hidden damage. If damage is discovered, file your claim immediately with the transport company. Perlick is not responsible for damage in transit.

**⚠ WARNING** Take caution when handling, moving and using the product to avoid damaging the refrigerant tubing or increasing the risk of a leak.

**⚠ DANGER** All service work shall be performed by factory authorized service personnel and all component parts shall be replaced with like components to minimize the risk of possible ignition due to incorrect parts or improper service.

**⚠ CAUTION** If service is necessary, repair work must be performed by a Perlick authorized servicer. Work done by unqualified individuals could potentially be dangerous and will void the warranty.

**⚠ CAUTION** Do not cut cardboard sleeve covering the unit. Cutting may result in damage to the exterior of the cabinet. Failure to follow this procedure may damage the compressor and void warranty.

1. Uncrate the unit on flat, level surface. Remove the cardboard sleeve by removing the banding securing the sleeve to the shipping base. Carefully lift the cardboard sleeve up over the top of the unit.
2. Carefully lift unit off the base and onto a hand truck or dolly. Make sure unit is balanced on transporting device using soft, flexible strapping. Protect unit surfaces with cloth material where strapping contacts unit.

**⚠ CAUTION** Do not lift unit by drawer, shelving or door handles or damage to the unit could occur.

**⚠ WARNING** To prevent personal injury, two people minimum required to lift the unit. Larger units may require additional personnel.

3. Before moving unit, secure door(s) to unit with tape to prevent from opening.

4. Carefully move unit to installation site and place in front of opening.

**⚠ CAUTION** Finished flooring should be protected with appropriate material to avoid damage from moving the unit.

### Plumbing

**⚠ CAUTION** Do not over-tighten drain fitting or damage to the threads could occur.

### Plumbing

#### Self-Contained

Condensate from the cooling coil is automatically evaporated from the condensate pan located in the condensing unit housing on self-contained models.

#### Self-Contained & Remote

Each unit is equipped with a floor drain located in the right rear corner of the cabinet. The drain can be plumbed to an external floor drain by connecting to the 3/4" NPT thread connection on the side, or the 1" NPS thread connection out the bottom, of the unit. Both drain ports come plugged from the factory and can be removed if needed.

### Remotes

Dispensing head drainers should be plumbed to a dump tank or floor drain. Always rinse drainer with sufficient amounts of water daily to prevent drain from clogging.

Remote evaporator condensate plumbing should be routed out on of the cabinet side access holes or to one of the floor drains and should always be sloped to the drain with no rise to prevent drainage. A trap should be used, however, trap peak must be below condensate drain pan nipple.

### Electrical

The cabinet must be connected to a separately fused power source (see Electrical Specification Plate affixed to unit) in accordance with National and Local electrical codes.

Self-contained Perlick units come equipped with a NEMA 5-15P 90° plug with an 6'5" cord extending beyond the rear of the cabinet. The electrical outlet must be flush with, or recessed into, the wall surface.

*NOTE: Never use an extension cord to extend the power cord to the electrical receptacle.*

**⚠ CAUTION** If unit has been laid on its back or sides, place unit upright and allow minimum of 24 hours before connecting power. Failure to follow this procedure may damage the compressor and void the warranty.

**⚠ CAUTION** Do not attempt to operate the equipment on any other power source than that listed on the Electrical Specification Plate attached to the unit.

**⚠ DANGER** **ELECTROCUTION HAZARD!** Electrical grounding is required. Appliances furnished with a 3-prong (grounding) polarized plug are equipped for your protection against possible shock hazards.

- Never remove the round grounding prong

from the plug.

- Never use a 2-prong adapter.
- Never use extension cord to connect power to the unit.
- If a 2-prong receptacle is encountered, or a longer power cord is required, contact a qualified electrician to have it replaced in accordance with applicable electrical codes.

**⚠ DANGER** Failure to comply with these electrical guidelines may result in possible death or serious injury, fire, or loss of property.

**NOTICE** This product contains blown foam insulation using blowing agent R-611 (Methyl Formate). The foam in this product does not contain HFC's, CFC's, or HCFC's.

## INSTALLATION

### General Information

- For units equipped with a power cord, the cord and plug may be aligned with a recess in the back panel to allow the unit to be pushed closer to the wall. For correct alignment, the wall outlet must be located 4" - 10" above the floor.
- Floor must be level in area of installation.

### Preparing the Space

**⚠ CAUTION** Make sure the floor under the unit is level with the surrounding finished floor. Protect a finished floor with plywood, cardboard or some other suitable material before moving the unit into place. Failure to do this may result in damage to the floor.

*NOTE: If unit has been laid on its back or sides, place unit upright and allow minimum of 24 hours before connecting to a power source. Failure to follow this procedure may damage the compressor and void warranty.*

1. Make sure the space opening is correctly sized for the unit. See Dimension drawings at the back of this manual for correct dimensions.

*NOTE: For a cabinet door to open properly, the door must open a minimum of 90°. Use a minimum 3" filler in corner installations to assure a 90° opening. Allow 24" clearance in front of the unit for full door swing and shelf/drawer pull-out.*

2. Check that the following are level and square:
  - Front and interior opening
  - Installation opening and floor surface

*NOTE: The floor under the unit must be at the same level as the surrounding finished floor.*

### Casters or Legs

Refer to the instructions included with the Casters or Legs Kit.

### Installing the Unit

**⚠ CAUTION** If unit has been laid on its back or sides, place unit upright and allow minimum of 24 hours before connecting power.

1. With power applied to the unit, check that the lighting and cooling functions operate properly, then turn off power to the wall outlet and/or circuit breaker.
2. Position the cabinet into place using rollers when necessary.

*NOTE: Proper air flow around the condensing unit is necessary for efficient operation. Never obstruct the air flow in and out of the condensing unit.*

3. When cabinet is in place, check installation with carpenter's level. When the unit is level front-to-back and side-to-side, accumulated water will drain out of cabinet to evaporator drain.
4. Turn on power to the outlet and/or circuit breaker.

## WOOD OVERLAY INSTALLATION

Before beginning installation, check all components for proper fit and finish. Handle should be installed to the overlay prior to installing overlay to door (use countersunk flathead fasteners for handle installation.)

**CAUTION** For best performance and functionality, the overlay panels should be 3/4" thick. The weight of the overlays should not exceed 20 lbs for solid (-2) doors, 10 lbs for glass (-4) doors, or 10 lbs for drawer (-6) models.

1. -2, -4 and -6 models come ready to accept wood overlay as shown below.



2. Remove the gasket carefully starting at the corners and avoid ripping the dart.



3. In some cases, the dart on the gasket may rip. If this happens, replace with a new gasket.



4. With the gasket removed, the screw holes needed to hold the overlay panel will be revealed as shown below.



- Loosely attached the four corners of the overlay panel with the door frame with #10 x 3/4" wood screws.

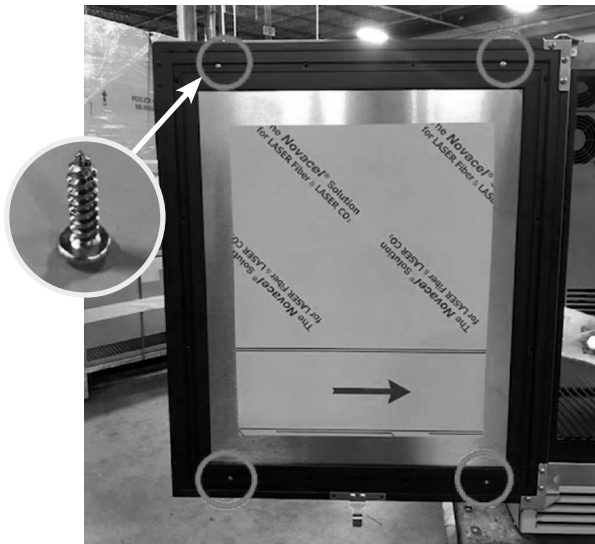

- After alignment is satisfied, fasten down all screws through the screw holes.



- Make sure the overlay panel is aligned properly with the door.



**⚠ CAUTION** Do not overtighten wood overlay attachment screws, as this may damage the factory supplied door frame.

- When re-installing the gasket, make sure the dart is pressed inside the slot on the door frame. Start at the four corners and firmly press your way inwards



- Verify that the gasket is fully seated onto the door frame when completed.



### WINE RACK TRIM (OPTIONAL)

All wine reserve racks come with sleek stainless steel fronts. Unfinished solid hardwood fronts are optional and can be removed and replaced with other wood to match your cabinetry. See diagrams below for wine rack face details.

*NOTE: The unfinished faces should be finished and sealed. In many cases, stains and/or finishes have odors that may be objectionable in an enclosed area. Do not stain or finish wood faces while installed on unit. To remove the front wood face from the wine shelf, simply pull out the wine shelf and remove the fasteners, finish as desired, and when completely dry, reinstall with fasteners.*

- After installation of the overlay panel is completed, verify that the gasket is completely sealing around the cabinet frame. If installing panels onto drawer models (-6), repeat installation process for second drawer face. Installation is now complete.

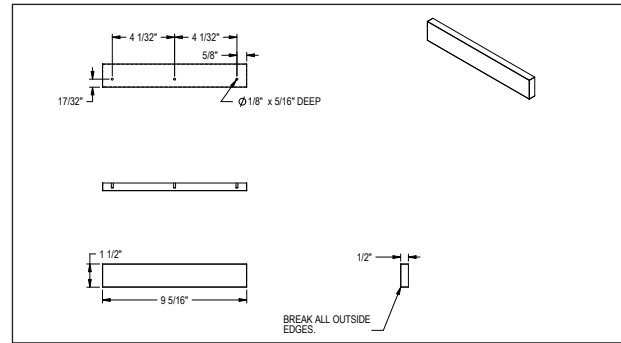

Wine Rack Trim, 15" models

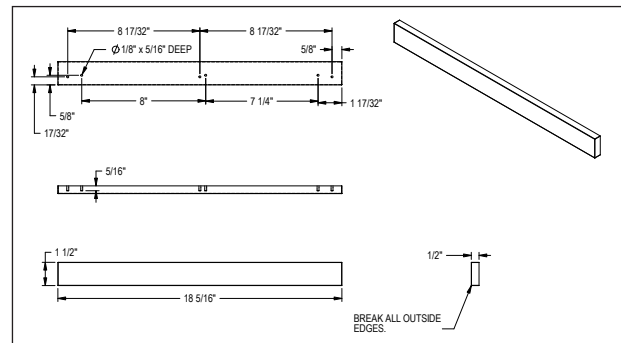

Wine Rack Trim, 24" models

## Electric Condensate Evapaway (Optional)

For installation in areas of high humidity, a 115-volt electric condensate pan can be installed underneath the cabinet to collect and evaporate the condensate from the cabinet evaporator. A 6' 3-prong plug is included. A separate circuit should be provided for the heater. The kit can be used only on cabinets equipped with 4" minimum legs; it cannot be used on units equipped with platform or base plate kits. Follow instructions supplied with the kit.

## Base Plate Installation (Optional)

Once the unit is secured in place, install the base plate brackets to the cabinet bottom in the holes provided. Attach base plate to brackets. Refer to the installation instructions included with the Base Plate Kit.

## Sealing Cabinet to Floor

For installation of a cabinet directly to the floor, (without legs or casters), the cabinet must be sealed to the floor to prevent liquid spillage passing under inaccessible portions of the equipment and to maintain the equipments NSF sanitation certification. The floor surface shall be level and smooth. It is recommended to be sealed to the floor using an NSF certified silicone sealer. (Figure 1).

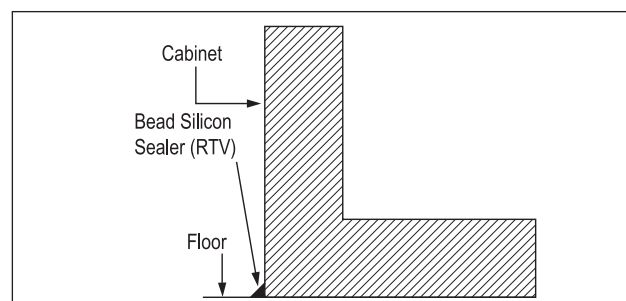

Figure 1: Sealing Cabinet to Floor

## Faucet and Dispensing Head Installation

Refer to the instructions included with the Faucet and Dispensing Head Kit.

# OPERATION

## Refrigeration and Temperature Control (Non-DZS Models)

The cabinet is equipped with a heavy-duty refrigeration system designed to automatically maintain a storage temperature of approximately 36° F.

Allow a minimum of 24 hours for ambient temperature product to reach storage temperature.

Draft beer should be stored at a temperature between 32° – 38° F. The most common cause of dispensing problems is improper temperature; beer will foam at warmer temperatures.

## Refrigeration and Temperature Control (DZS)

The unit is equipped with a heavy-duty, digitally controlled, dual-zone refrigeration system designed for two separate compartments.

The temperature controls have been factory set according to customer specifications based on intended use. The digital controller on the left controls the compartment on the left side and the digital controller on the right controls the compartment on the right side.

- Factory temperature settings: Approximately 36°F for refrigerator, 45°F for white wine storage (compartment closest to the condensing unit/refrigeration module), and 60°F for red wine storage. Adjustable range is 34°F - 42°F for the refrigerator and 40°F - 60°F for wine.
- Coldest compartment must always be the compartment closest to the condensing unit/refrigeration module.
- Minimum temperature difference between two compartments is 10°F. Maximum temperature difference between the two compartments is 30°F for the DZS60 Model and 20°F for the DZS36 Model.
- The unit is not intended for temperature settings outside the parameters mentioned above. Attempts to deviate from the specified temperature parameters may result in unsatisfactory serving temperatures.

Allow a minimum of 24 hours for ambient temperature product to reach storage temperature.

Beer will freeze at temperatures lower than 30° F. When beer freezes, the alcohol in the beer may separate and cause the beer to be cloudy with an “off” taste.

The following chart shows how temperature affects beer:

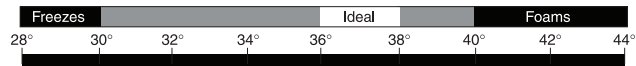

### Checking Product Temperature

1. To accurately check the temperature of product stored in the refrigerated compartment, insert an accurate thermometer into a plastic unbreakable bottle, partially filled with water. Tighten bottle cap securely.
2. Place the bottle in the desired area for 24 hours. Refrain from opening the unit during the testing period. After 24 hours, check the temperature of the water. Adjust the temperature accordingly using the procedures on this page.

The following factors affect the internal temperature of the unit:

- Temperature setting
- Room temperature where installed
- Number of times the door is opened and closed
- Length of time door is left open
- Style of door installed
- Door gasket seal and condition
- Amount of time the internal light is illuminated
- Installation in direct sunlight or near a heat source

### Interior Light (Not applicable to all models)

The unit is equipped with an interior LED light in the upper front of the unit just inside the door or drawer. The light illuminates when the manual rocker light switch is turned on. The rocker light switch is located behind the LED light on the inside of the frame on either the right or left side (same side as the compressor).

### Digital Temperature Control

To Adjust the Temperature Set Point (Figure 2):

1. Press the **set** button. The label “SET” will be displayed.
2. Press the **set** button a second time. The set point will be displayed.
3. To change the Set point value, press the **▲** or **▼** keys within 15 seconds.
4. Press **set** to confirm the new setpoint value.
5. After 10 seconds the display will return to indicating the cabinet temperature.



Figure 2: Digital Temperature Controller

## ADJUSTMENTS

### Changing Door Swing Direction

*NOTE: Changing the door swing direction is not advisable if the door is not equipped with a full length handle. Doing so may result in an undesirable handle position..*

#### Hinge Kits

Part No. 67439R: Right Hinging

Part No. 67439L: Left Hinging

#### Tools Required

- Large flat head screwdriver
- Regular Phillips head screwdriver
- Hinge Kit from Perlick
- Plastic putty knife

#### Procedure

1. Support the door in the open position as shown in Figure 3. Remove the hinge pin.

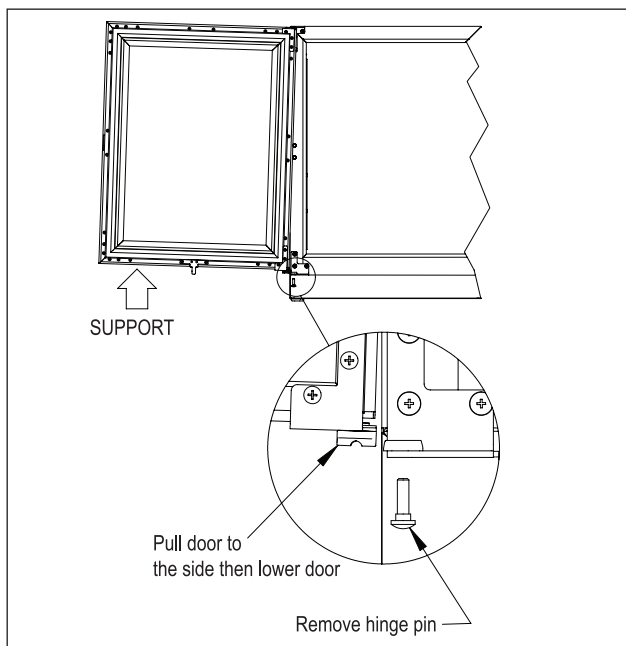

**Figure 3: Door Removal**

2. Pull door to the side and then lower the door.
3. Remove top and bottom hinge brackets. Retain screws for later use. See Figure 4.
4. Remove the hole plugs from the top and bottom hinge bracket mounting holes (Figure 4). Place the plug in the holes on the opposite side made vacant by removing the hinges in step 3.

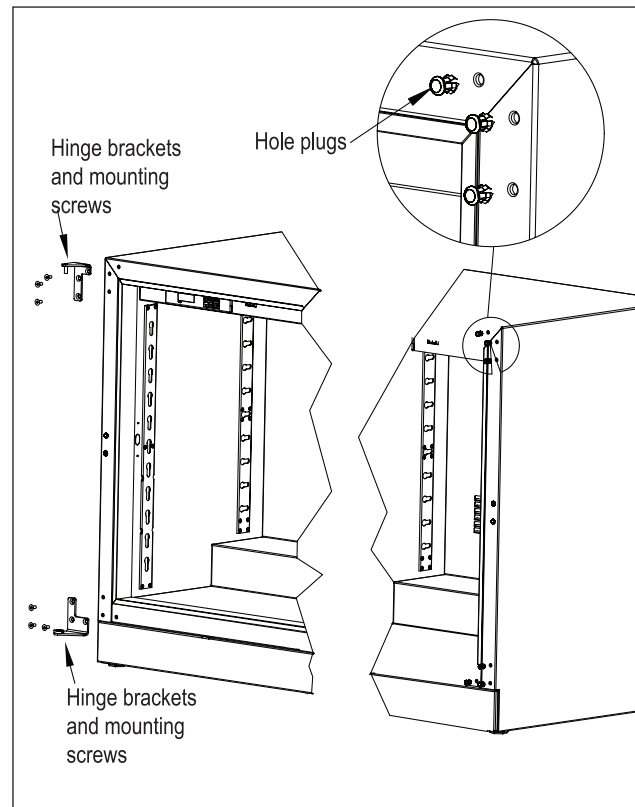

**Figure 4: Hinge Removal**

5. Using the screws removed in step 3, install the top and bottom hinge brackets from kit (Figure 5).

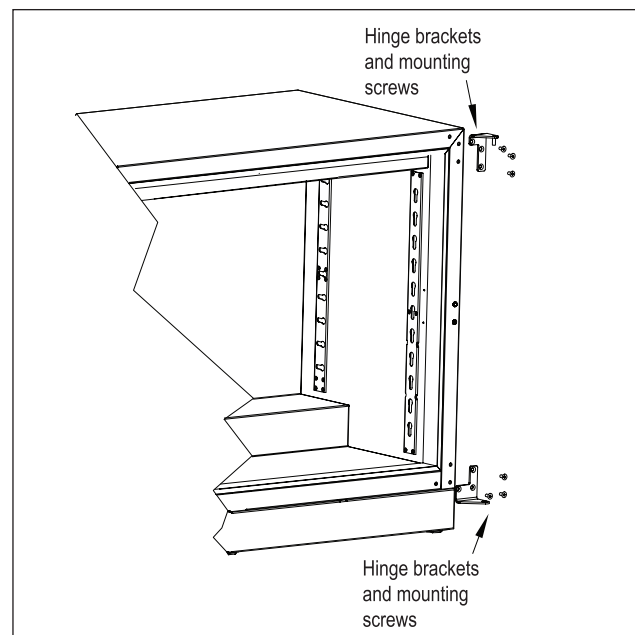

**Figure 5: Hinge Installation**

- Remove the top and bottom hinge brackets from the door (Figure 6). Retain the screws for later use.

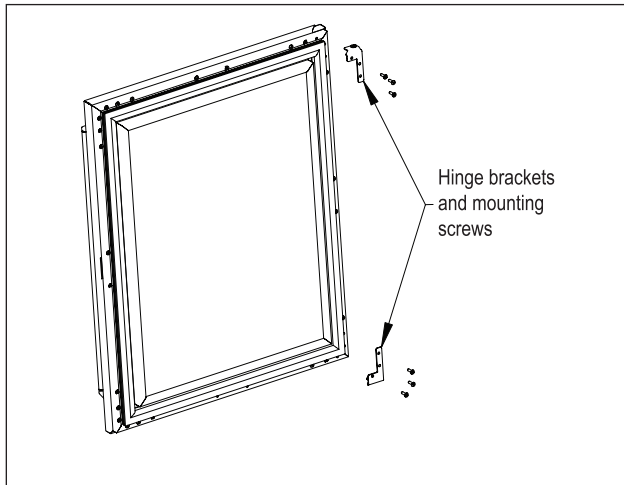

**Figure 6: Door Brackets**

- Remove the front panel from the door assembly by removing the inner mounting screws, 4 per side, from the perimeter of the door assembly (Figure 7). Rotate the front panel 180°. The top becomes the bottom. Reattach using the same screws and mounting holes.

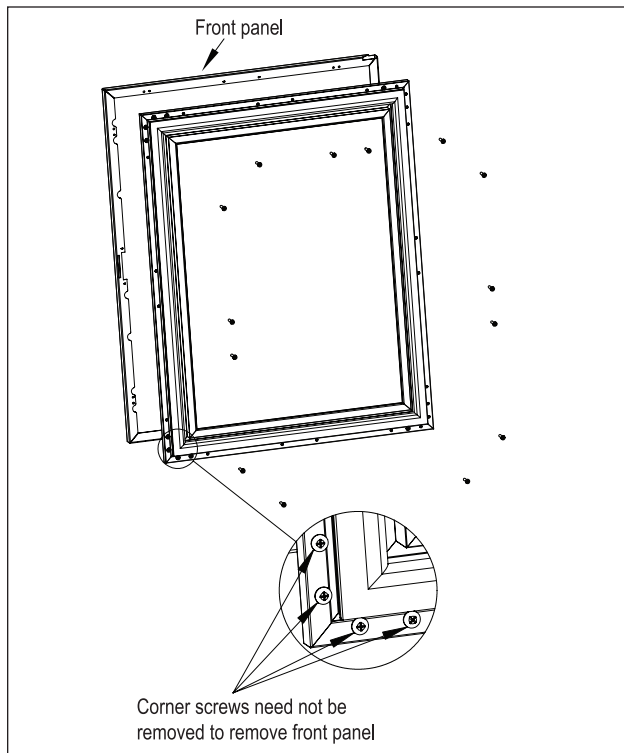

**Figure 7: Removing Front Panel**

- Insert bearing into door top hinge bracket (Figure 8).

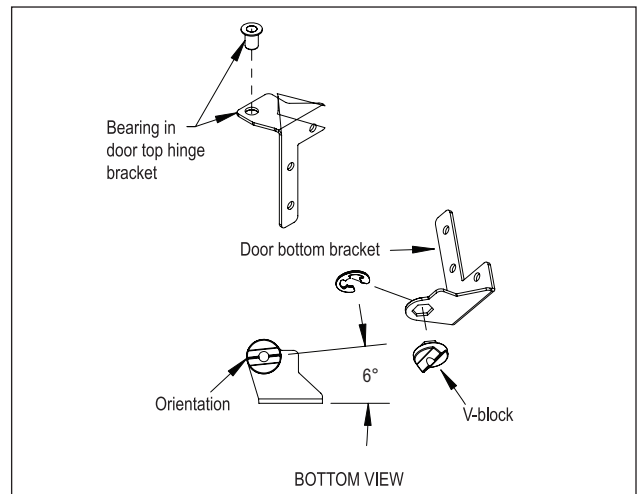

**Figure 8: Bearing and V-Block**

- Insert V-block into door bottom hinge bracket and attach with e-clip (Figure 8). Note the orientation of the V-block.
- Attach the top and bottom door hinges using the screws removed in step 6 (Figure 9).

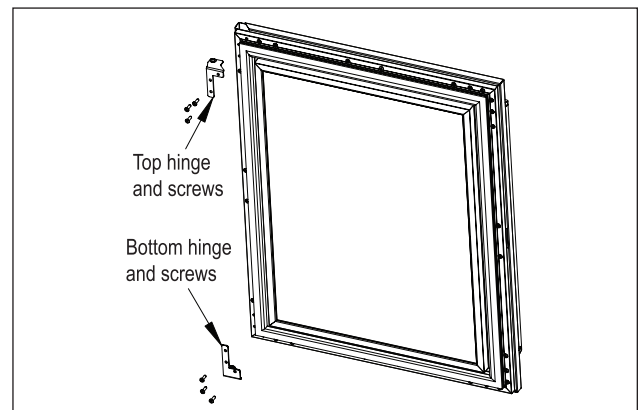

**Figure 9: Door Hinges**

- Place lower V-block into lower cabinet hinge with notch parallel to cabinet (Figure 10).

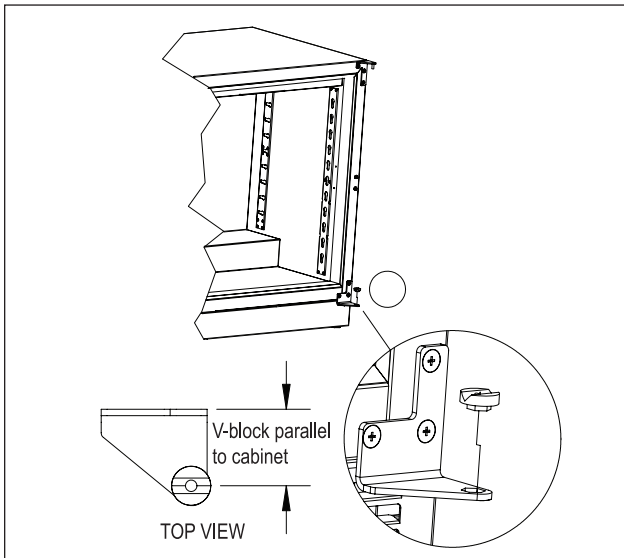

**Figure 10: Installing V-Block**

12. Lift door assembly and insert top pin into bearing. Move door toward cabinet and align V-blocks (Figure 11).

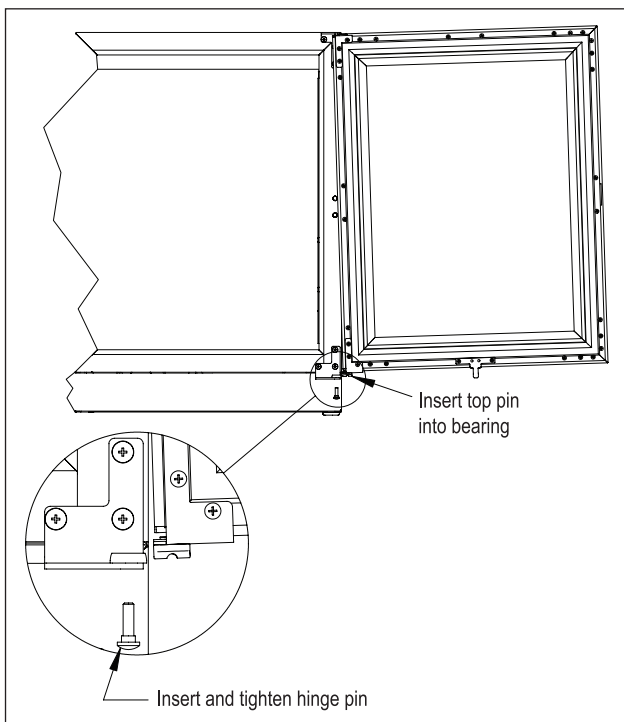
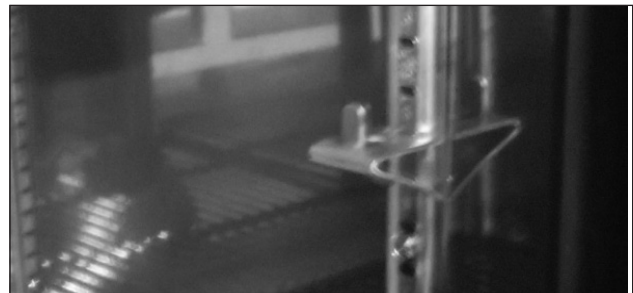

**Figure 11: Installing Door**

13. Insert and tighten lower hinge pin to complete assembly.

### Shelving Adjustment

See Figure 12.



**Figure 12: Shelf Bracket**

**CAUTION** Completely empty shelf or drawer before removing.

1. Open the door. Tilt the shelf and remove it from the unit
2. Reposition each bracket separately. Grasp the middle of the bracket, pull the front end up and out, then forward to remove it.
3. Place brackets at desired location and reinstall shelf(s)

### Drawer Dividers Adjustment

See Figure 13.

**CAUTION** Completely empty shelf or drawer before removing.

Lift divider straight up and move to desired position, engaging tabs in holes. Make sure divider tabs engage corresponding holes on both sides.



**Figure 13: Drawer Divider Adjustment**

## Sliding Doors

### Removing/Installing

1. To remove the sliding door, simply grasp the door on each side and lift up off the bottom track, then tilt outwards and pull down to remove from the upper track.
2. To reinstall sliding door, place door in upper track making sure to engage the bracket (Figure 4), lift door up into the track and place into the bottom track.



**Figure 14: Removing/Installing Sliding Door**

### Adjusting Door Spring Tension

A tension spring is located in the upper track of each door. To increase or decrease spring tension, remove the Phillips screw and position the bracket in one of three detentes and reinstall screw. The detente farthest to the left creates the least amount of tension.

*NOTE: Units are shipped from the factory with springs set at the weakest settings.*

### Sliding Door Lock

Each set of sliding doors is equipped with a keyed lock located on the bottom of the right side door. To lock the doors, place the lock lever in the “DOWN” position and lock with the key. Unlock with the key and place the lever in the “UP” position to open.

## MAINTENANCE

**⚠ DANGER** Never attempt to repair or perform maintenance on the unit until the main electrical power to the unit has been disconnected!

**⚠ WARNING** Take caution when handling, moving and using the product to avoid damaging the refrigerant tubing or increasing the risk of a leak.

### LED Light Replacement

See Figure 15.

1. Open the door, or remove the upper drawer (see Removing Drawer, Figure 16).

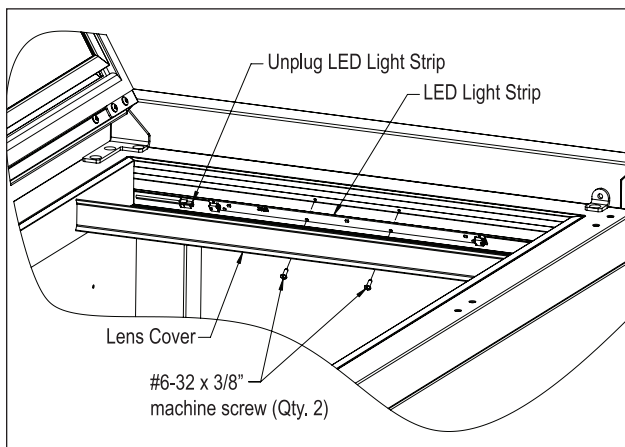

**Figure 15: Interior LED Light**

2. Using a flat blade screwdriver, carefully pry off the lens cover.

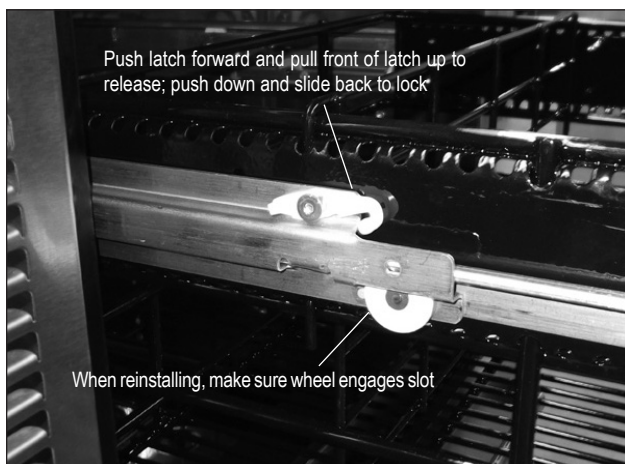

**Figure 16: Removing/Installing Drawer**

3. Remove the two screws securing LED light to housing.

4. Unplug the LED from the wiring harness.
5. Plug new LED into harness and secure to housing using screws removed in step 2.
6. Snap LED cover into place.

### Cleaning/Lubricating Drawer Extenders

Drawer must be removed to clean or lubricate the extenders. Use a food grade lubricant to lubricate the drawer extenders.

### Removing Drawer

See Figure 15.

**⚠ CAUTION** Completely empty drawer before removing.

1. Pull the drawer out to its furthest position. Locate the latch in the middle of both extenders. Push each latch forward and lift front of latch up (unlocked position), then lift the front of the drawer and pull out.

### Installing Drawer

1. Place drawer on to the extenders, making sure wheels engage the slots on each side.
2. Push drawer all the way in, then pull drawer out and push the latch down and back to engage. Make sure front of latches are fully down and back, engaging the extenders.

## Stainless Steel Care & Cleaning

### General

Contrary to popular belief, stainless steel is susceptible to rusting. Corrosion on metals is everywhere. It is recognized quickly on iron and steel as unsightly yellow/orange rust. Such metals are called “active” because they actively corrode in a natural environment when their atoms combine with oxygen.

Stainless steel is a “passive” metal because it contains other metals like chromium, nickel and manganese that stabilize the atoms. Chromium provides an invisible passive film that covers the steel surface acting as a shield against corrosion. As long as the film is intact and not contaminated, the metal is passive and stainless. If the passive film of stainless steel has been broken, equipment starts to corrode and rust.

There are three basic things which can break down stainless steel's passive layer and allow corrosion to occur:

- Mechanical abrasion
- Deposits and water
- Chlorides

**Mechanical abrasion** refers to the things that will scratch a steel surface. Steel pads, wire brushes and scrapers are prime examples.

**Water** comes out of the faucet in varying degrees of hardness. Depending on what part of the country you live in, you may have hard or soft water. Hard water may leave spots. When allowed to sit, these deposits will break down the passive layer and rust stainless steel. Other deposits from food preparation must be promptly removed with an appropriate cleaning agent.

**Chlorides** are found nearly everywhere. They are in water, food and table salt. Household and industrial cleaners are the worst offenders.

#### Preventing Stainless Steel Rust

Use the proper tools. Use non-abrasive tools to clean stainless steel products. Soft cloths and plastic scouring pads will not harm the steel's passive layer.

Clean with polish lines. Some stainless steels come with visible polishing lines or "grain". When visible lines are present, always scrub in a motion parallel to the lines. When the grain cannot be seen, play it safe and do not use a circular motion. Polish in a consistent straight pattern.

Use alkaline, alkaline chlorinated or non-chloride containing cleaners. While many traditional cleaners are loaded with chlorides, the industry is providing an ever-increasing choice on non-chloride cleaners. If you are not sure of chloride content in the cleaner being used, contact your cleaner supplier. If your present cleaner contains chlorides, ask your supplier if they have an alternative. Avoid cleaners containing quaternary salt; it also can attack stainless steel and cause pitting and rusting.

Keep food equipment clean. Use alkaline chlorinated or non-chloride cleaners at recommended strength. Clean frequently to avoid build-up of hard, stubborn stains. The single most likely cause of damage is chlorides in the water. Remember, adding heat to cleaners that contain chlorides dramatically increases their effect on stainless steel.

Rinse, rinse, rinse! If chlorinated cleaners are used, immediately rinse and wipe equipment and supplies dry. The sooner you wipe standing water, especially when it contains cleaning agents, the better. After wiping equipment down, allow it to air dry. Oxygen helps maintain the stainless steel passive film.

#### Cleaning Cabinet Interior/Exterior

**⚠ CAUTION** NEVER use hydrochloric acid (muriatic acid) on stainless steel. Do not use abrasive cleansers or cloths on any interior or exterior surfaces or removable parts.

Glass panels may be cleaned using any standard glass cleaner available on the market.

To clean interior and exterior non-metallic surfaces and removable parts, wash with a mild solution of soap and lukewarm water with a little baking soda. Rinse and dry thoroughly. Avoid getting water on lights, controller and fan motors.

#### Cleaning the Condenser

**⚠ DANGER** Flammable Refrigerant. Risk of fire or explosion. Do not damage refrigeration tubes.

The condenser (located behind front grille cover) should be cleaned every three (3) months. Use a soft bristle brush and vacuum to remove the dust and lint.

**⚠ CAUTION** Avoid damaging or crushing the condenser fins or tubing. Failure to follow this procedure may damage the compressor and void the warranty.

### Recommended Cleaners for Specific Situations

Job	Cleaning Agent	Comments
Routine cleaning.	Soap, ammonia, detergent	Apply with sponge or soft cloth.
Fingerprints and smears.	Areal 20, Lac-O-Nu, Lumin Wash, O'Ceder Cream Polish	Provides barrier film to minimize fingerprints. Can be used on all finishes. Rub the surface with a cloth as directed on the package.
Stubborn stains and discolorations.	AllChem Concentrated Cleaner, Samae, Twinkle, Cameo Copper Cleaners, Grade FFF Italian Pumice Whiting, Steel Bright, Lumin Cleaner, Zud Restoro, Sta-Clean, Highlite Cooper's Stainless Steel Cleaner or Revere Stainless Steel Cleaner.	Apply with a damp sponge or cloth, then rinse with clear water and wipe dry.
	Old Dutch, Lighthouse Sunbrite, Wyandotte Bab-O, gold Dust, Sapollo, Bon Ami or Comet.	For these household cleaners, rub with a damp cloth. They may contain chlorine bleaches so rinse thoroughly after use and wipe dry
	Liquid NuSteel or Dubois Temp	For these products, rub the surface with a dry cloth using only a small amount of cleanser. Rinse with water and dry.
Heat tint or heavy discoloration.	Penny-Brite, Copper Brite, Paste Nu-Steel, Dubois Temp or Tarnite	Rinse and rub onto surface with a dry cloth.
	Bar Keepers Friend, Revere Stainless Steel Cleaner, Allen Polish, Steel Bright Wyandotte Bab-O or Zud.	When using these cleaners, apply with a damp sponge or cloth, rinse thoroughly and wipe dry.
Tenacious deposits, rust, discoloration, industrial atmospheric stains.	Oakite No. 33 Dilac, Texo NY, Flash-Klenz Caddy Cleaner, Turco Scale 4368 or Permabag 57.	Use Swab and soak with a clean cloth. Let stand for 15 minutes or more according to directions on package then rinse and wipe dry.
Rust discoloration or corrosion caused by cleaning agents containing hydrochloric (muriatic) acid or chlorine bleach	3M Scotch Brite pad, type A Grade "Fine"	Clean off the surface soil using cleaning methods above. Then rub discolored or corroded areas lightly with dry pad.
<p><i>Use of property names is intended only to indicate a type of cleaner and does not constitute an endorsement. Omission of any proprietary cleaner does not imply its inadequacy. All products should be used in strict accordance with instructions on the package.</i></p> <p><b>NOTE: Do not use steel wool or scouring pads to clean stainless steel.</b></p>		

## TROUBLESHOOTING

### Before Calling For Service

If the unit appears to be malfunctioning, read through the Operation section in this manual first. If the problem persists, check through this troubleshooting section. Locate the problem and refer to the cause and remedy before calling for service. The problem could be something that can be solved without a service call.

** DANGER** Never attempt to repair or perform maintenance on the unit until the main electrical power to the unit has been disconnected!

Problem	Cause	Solution
No interior light.	Rocker switch in Off position.	Turn switch on.
	LED board inoperable.	Contact your selling dealer.
Light stays on when door is closed.	Manual switch on.	Turn manual switch off.
Noisy operation.	Soft sounds from compressor, fan motor and valves heard.	Normal operation.
LED Controller display is flashing "E1".	Thermostat probe failure.	Contact your selling dealer.
Unit is not running.	No power to the unit.	Home circuit breaker tripped. Reset circuit breaker.
	Condenser dirty.	ON/OFF keypad is off. Turn on. Clean the condenser.
Compartments are warmer than usual.	Control preset not set properly.	Reset compartments presets.
	Light staying on. Condenser dirty or obstructed. Door is open or has been opened more frequently lately. Internal louvers and/or fan guard obstructed. Warm product placed in cabinet recently.	Turn manual light switch off. Clean condenser and clear obstruction. Wait 24 hours and recheck temperature. Reset preset temperature if necessary. Make sure louvers and/or fan is not obstructed.
System runs for long period of time.	Condenser dirty or obstructed.	Clean condenser and clear obstruction.
	Door kept open for long time or opened more frequently. Warm product place in cabinet recently. Hot day and warm room temperature.	Wait 24 hours and recheck temperature. Reset preset temperature if necessary. Normal for system to run more frequently.
Condensation forms inside the compartments.	High humidity and/or frequent door opening.	Normal operation.
	Door not closing and sealing properly.	Make sure door is closing properly. Check door seals and replace if necessary.
Condensation forms on outside of unit.	High humidity and/or frequent door opening.	Normal operation.
	Door not closing and sealing properly.	Make sure door is closing properly. Check door seals and replace if necessary. If condensation persists, contact your selling dealer.

### For Product Information

- Contact your selling dealer.
- Inquire via the web at [www.perlick.com](http://www.perlick.com)
- Call (800) 558-5592 for factory assistance on planning installation or product information.
- Write to Perlick Corporation, Customer Service Department, 8300 West Good Hope Road, Milwaukee, WI 53223.
- Email us at [warrantyserv@perlick.com](mailto:warrantyserv@perlick.com).

### For Product Service

- Check the model and serial number of your unit located on the label attached to the inside top of the cabinet.
- Inquire via the web at [www.perlick.com](http://www.perlick.com), or call (800) 558-5592.

### For Replacement Parts and Accessories

- Use only genuine Perlick replacement parts and accessories. Genuine Perlick parts and accessories are designed to work correctly with Perlick products and offer superior service life. The use of non-Perlick parts can damage the unit and may void the warranty.
- Check the model and serial number of your unit which is located on the right or left interior panel. Call your Perlick Factory Authorized Service Center.
- Inquire via the web at [www.perlick.com](http://www.perlick.com), or call (800) 558-5592.

Genuine Perlick replacement parts and accessories have been tested and approved for use with flammable refrigerants to prevent hazardous conditions.

**DIMENSIONS**

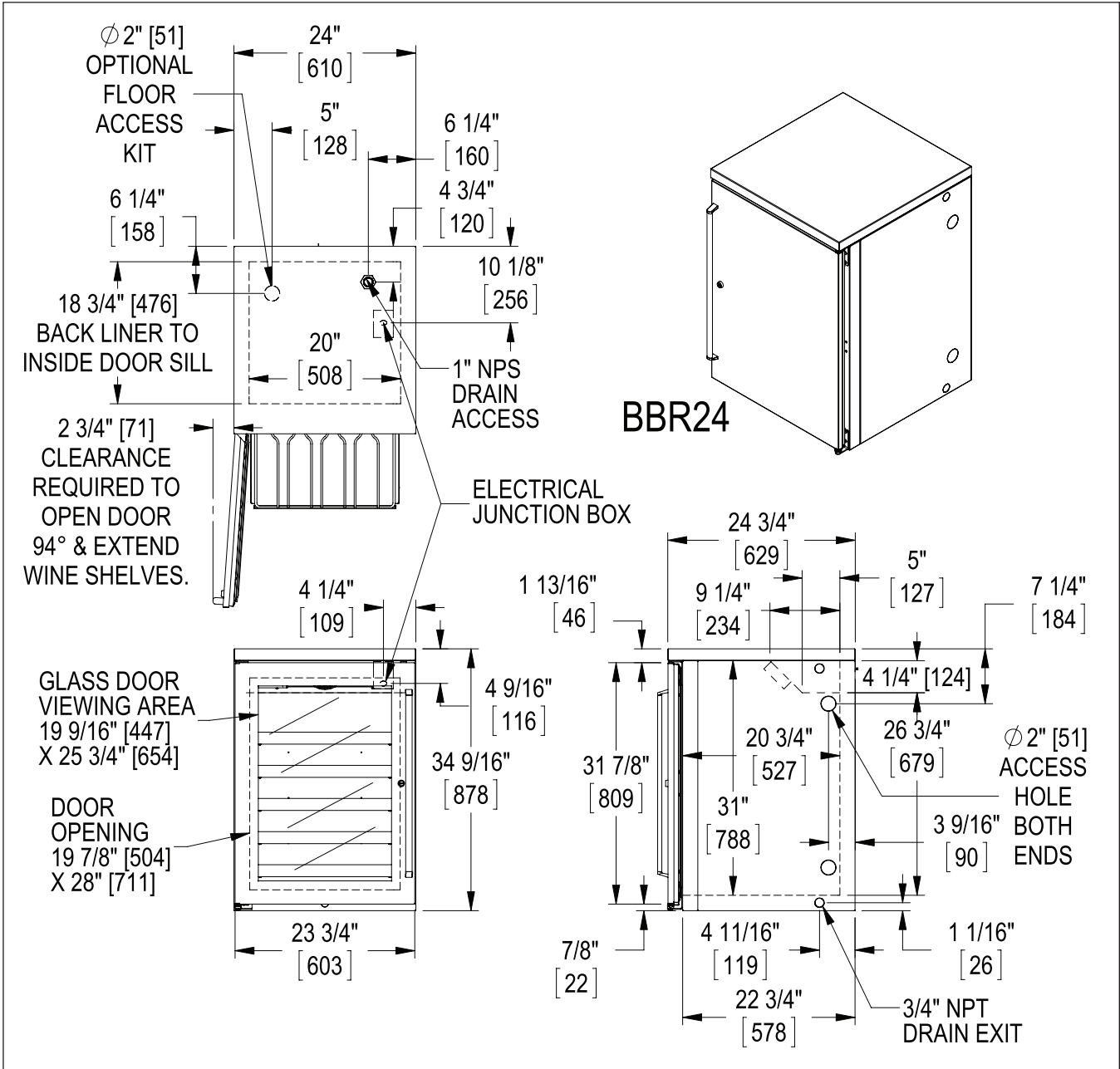

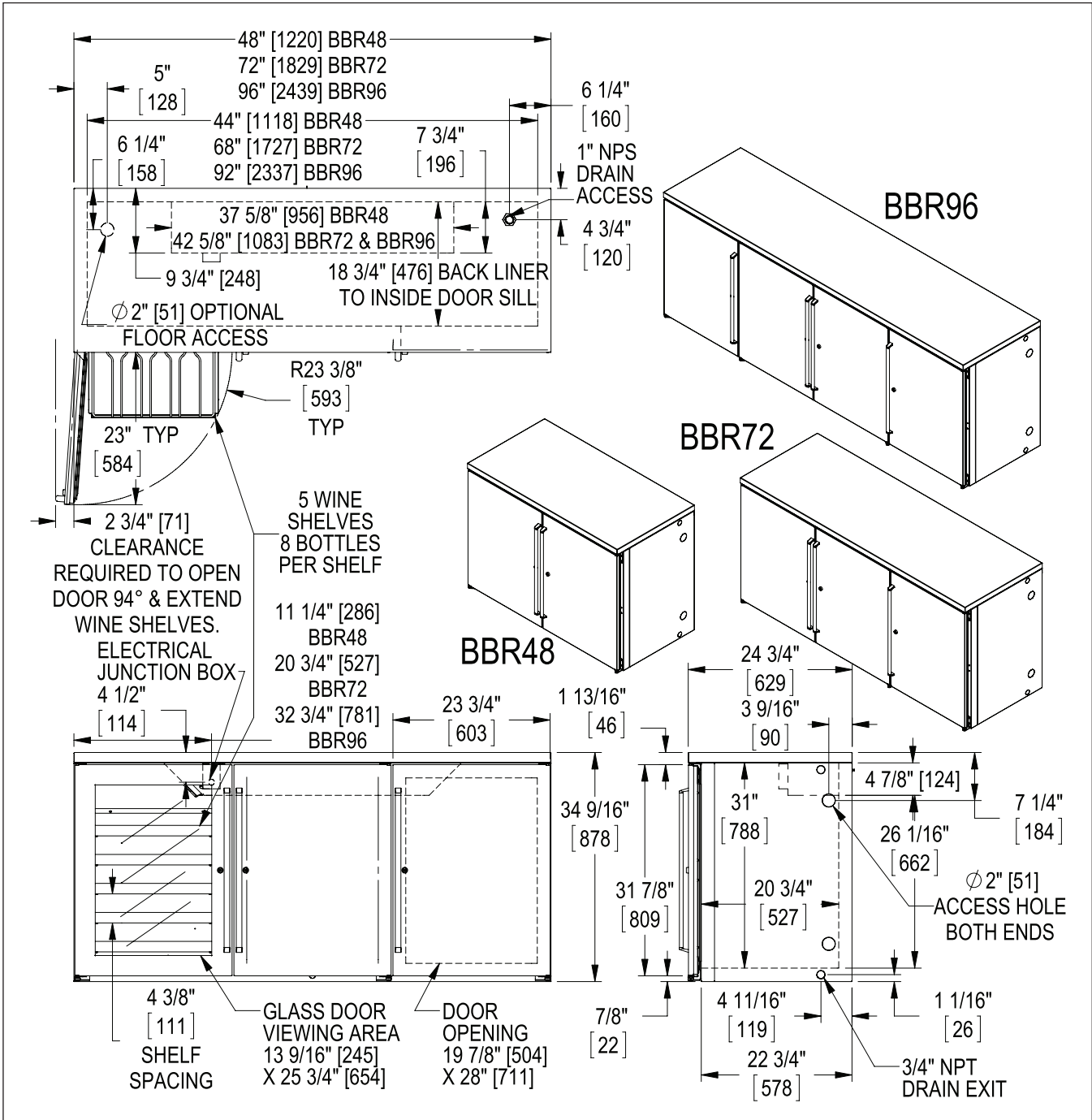



**BBSLP108**  
Unit Left

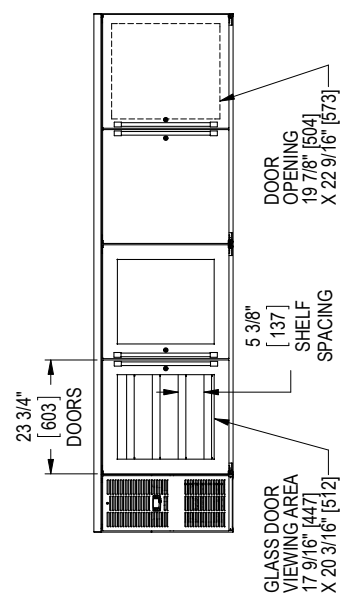
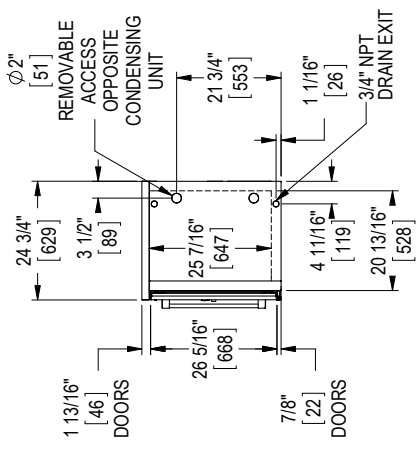
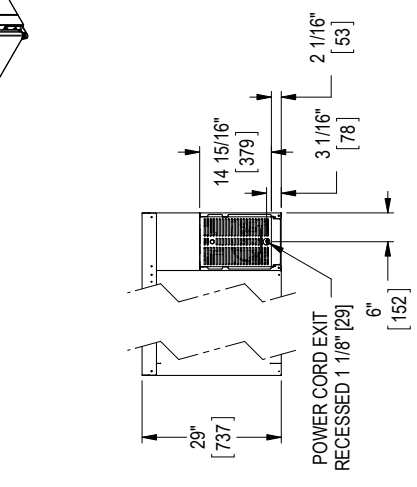
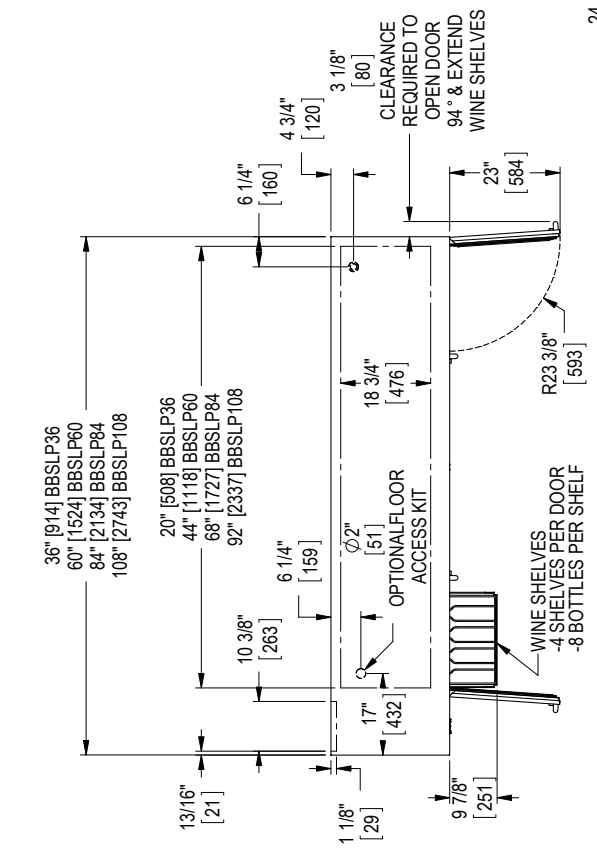
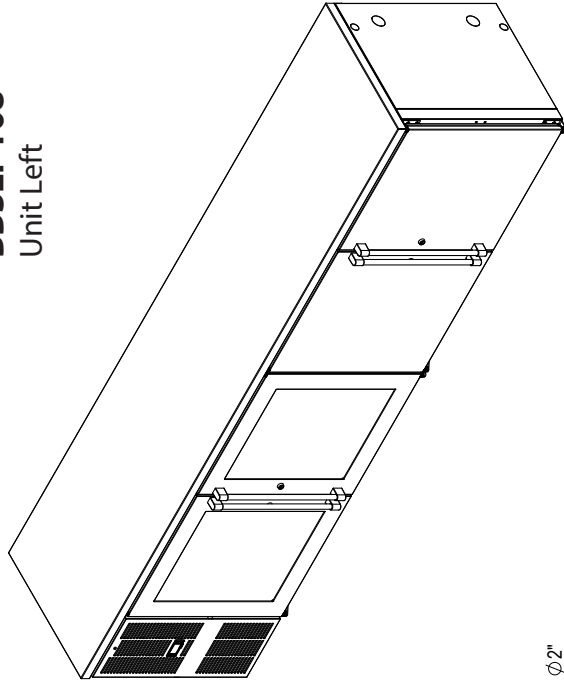

**BBRLP72**

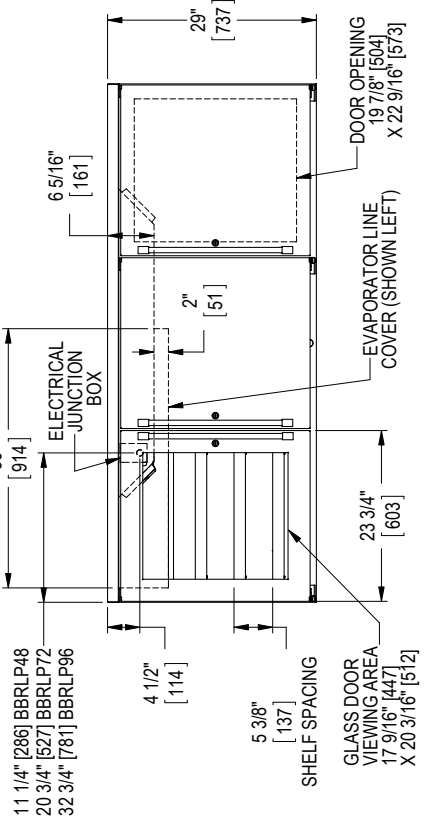
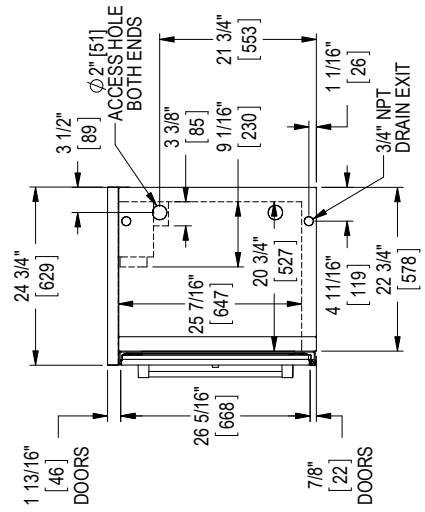
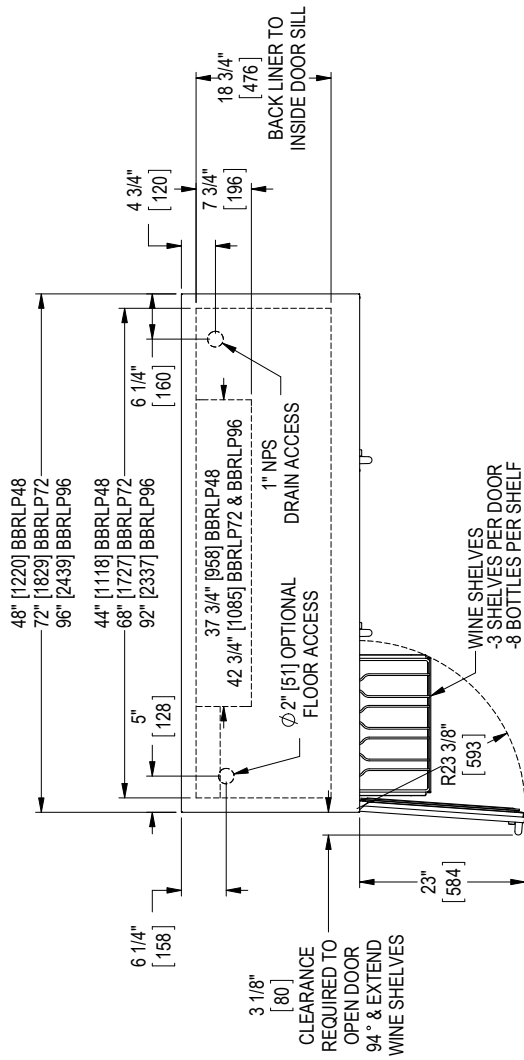
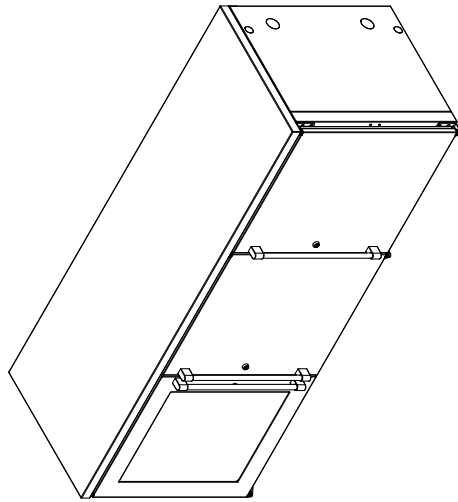

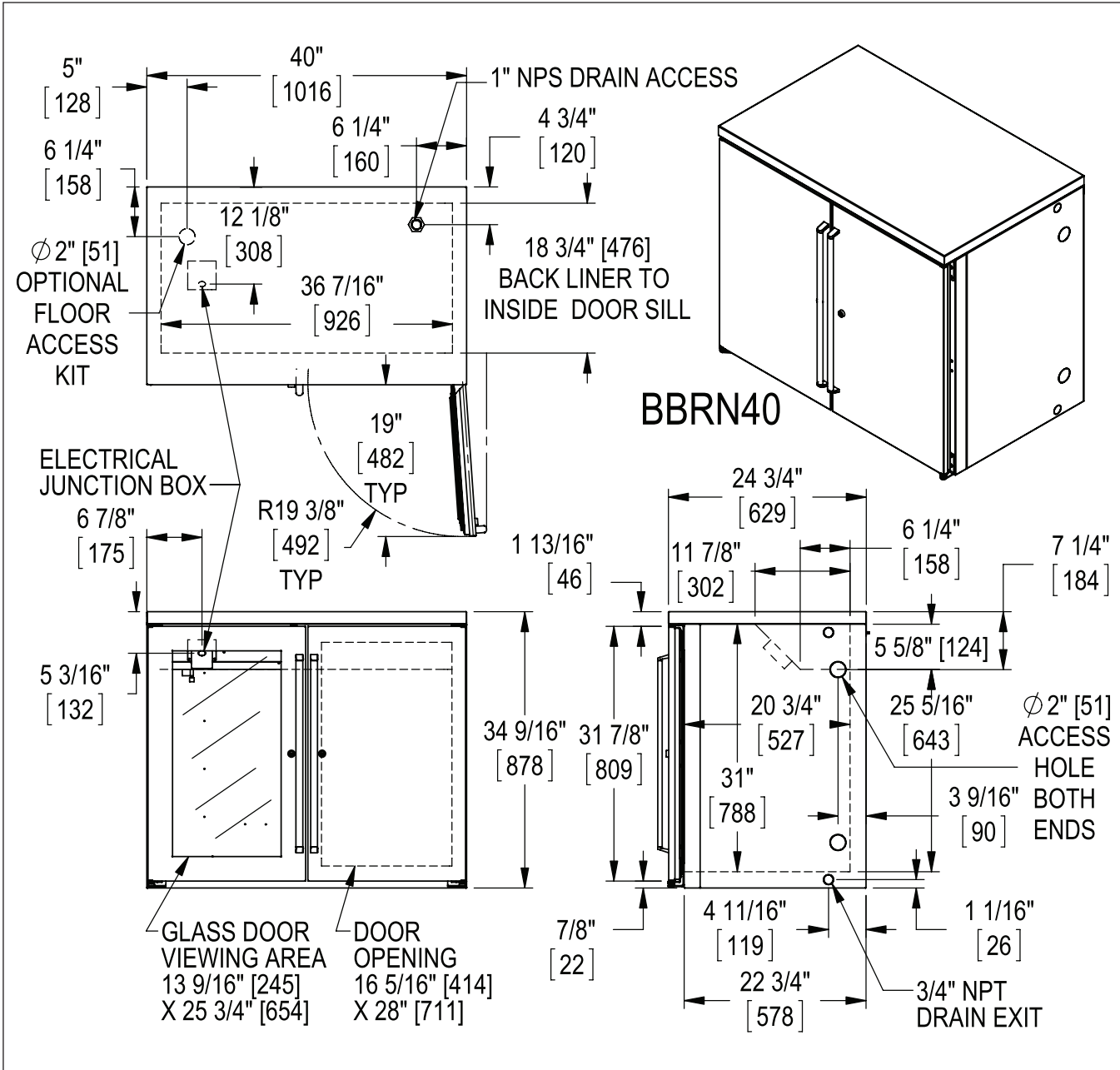

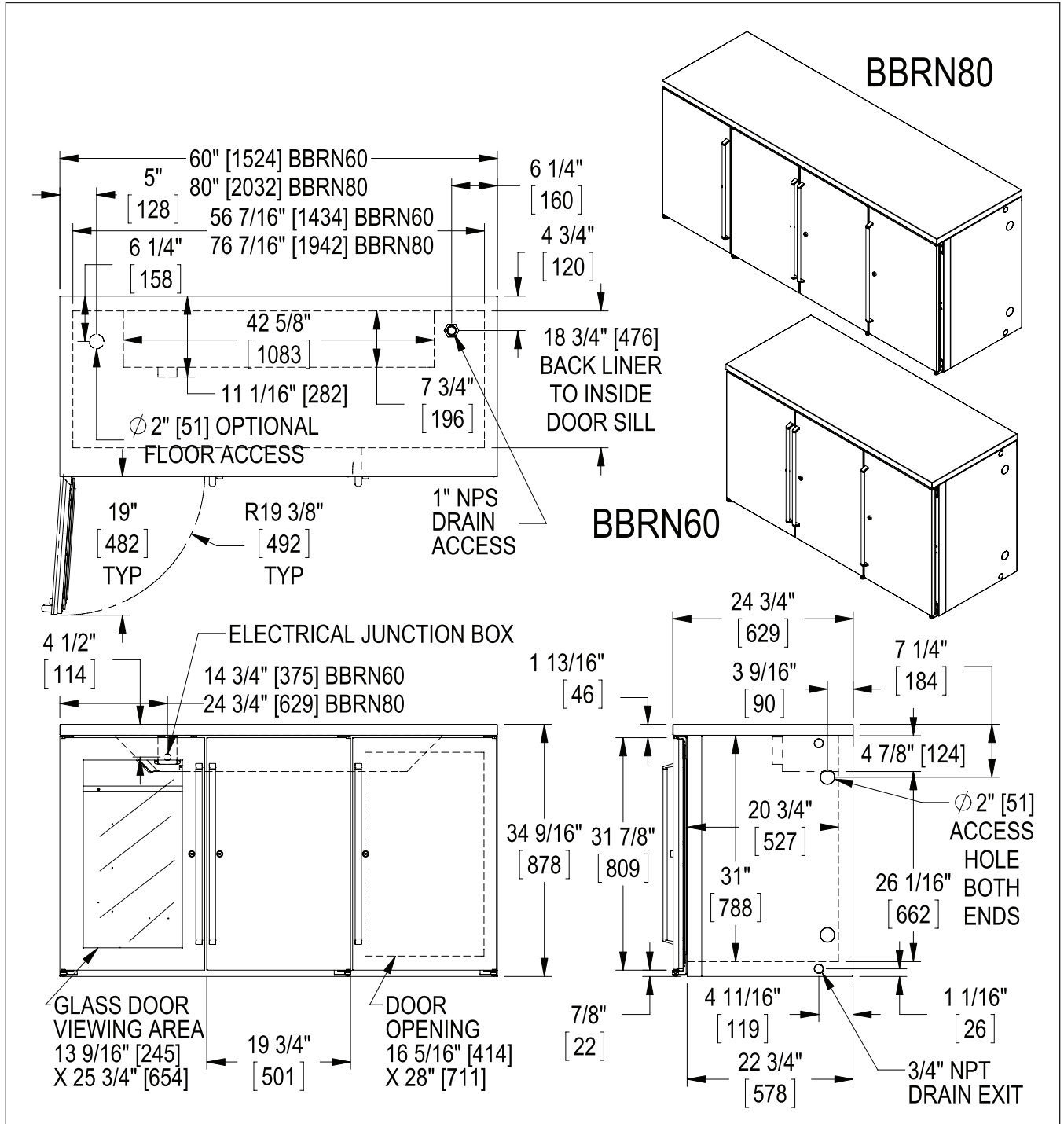

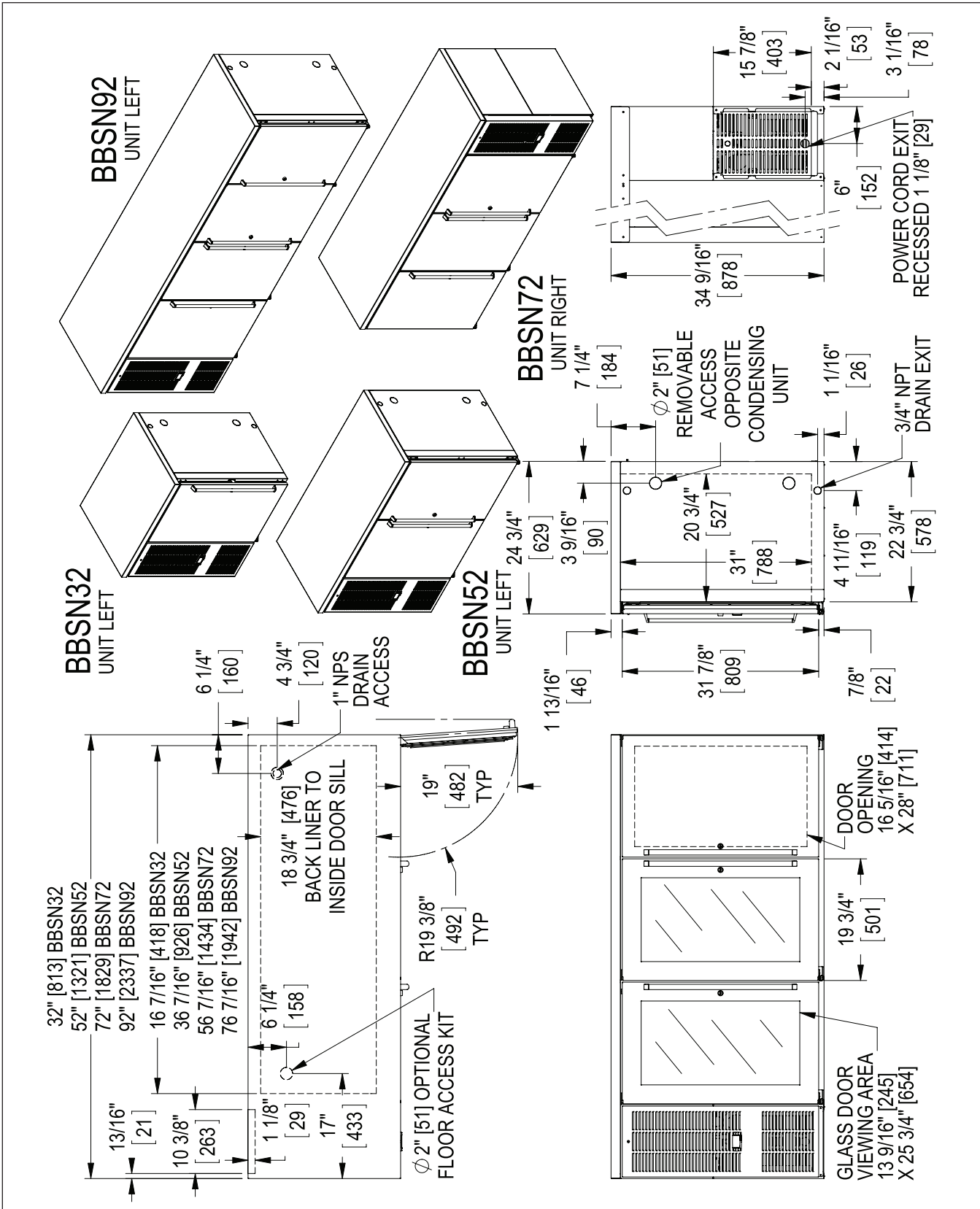

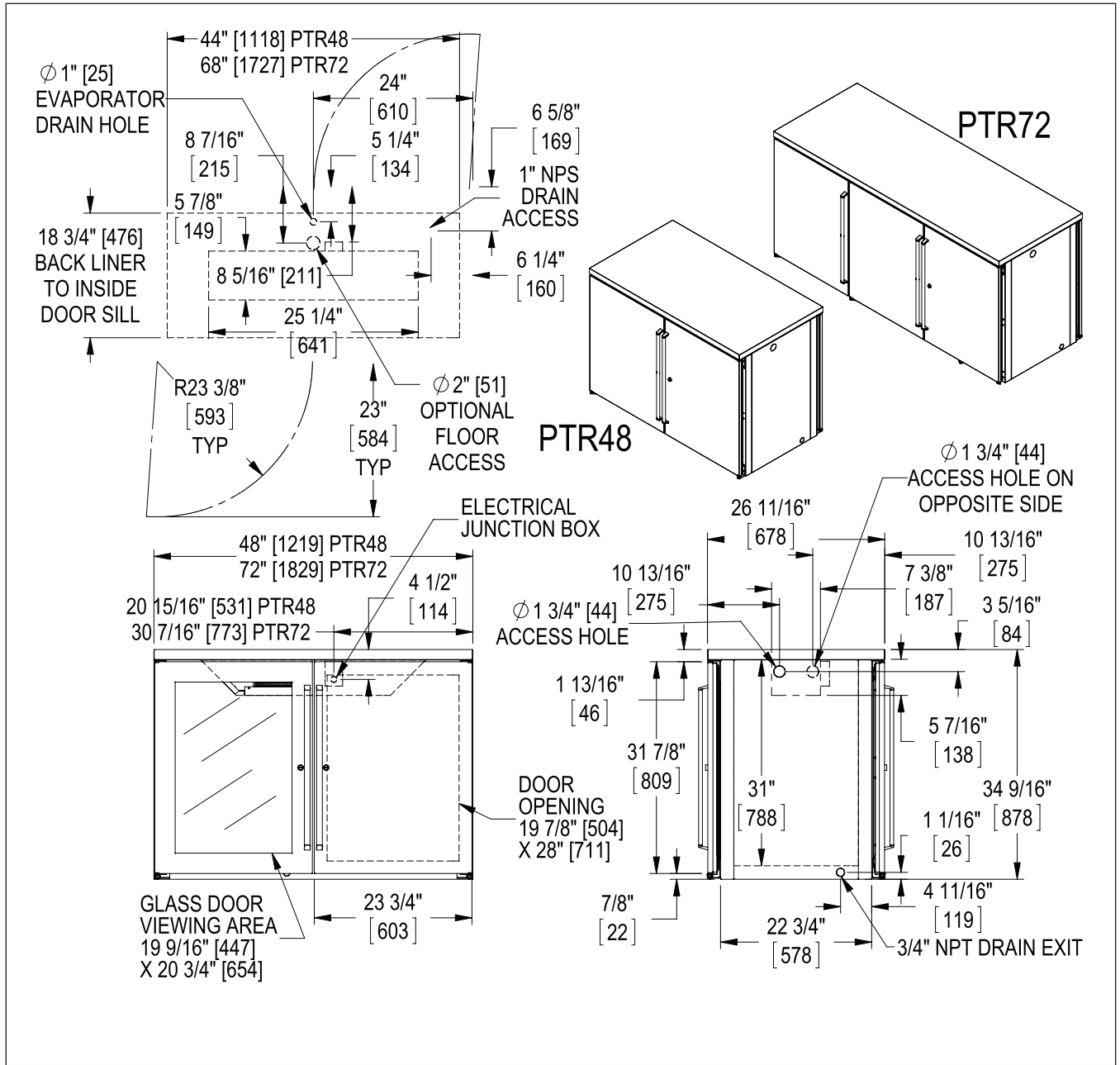

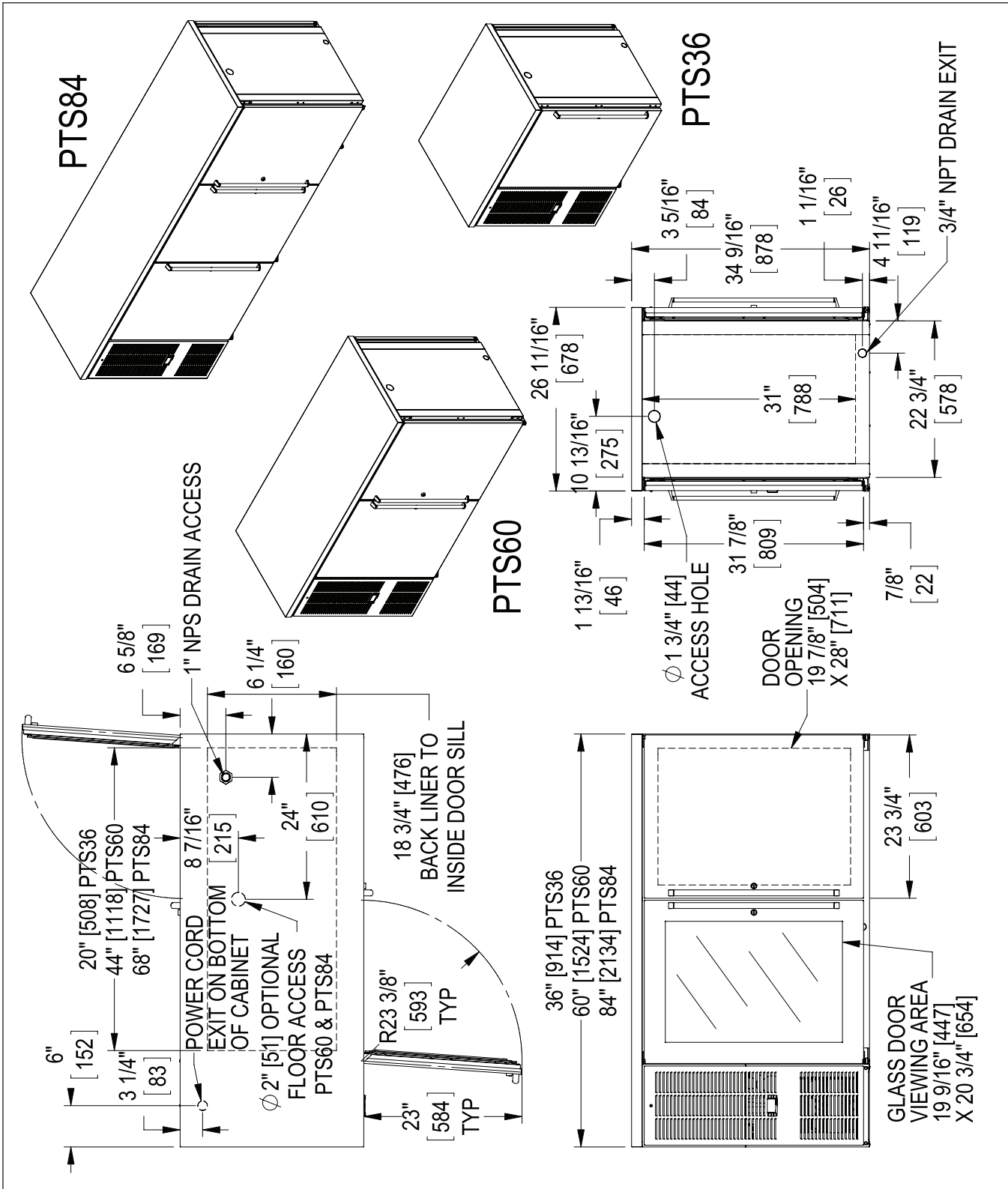

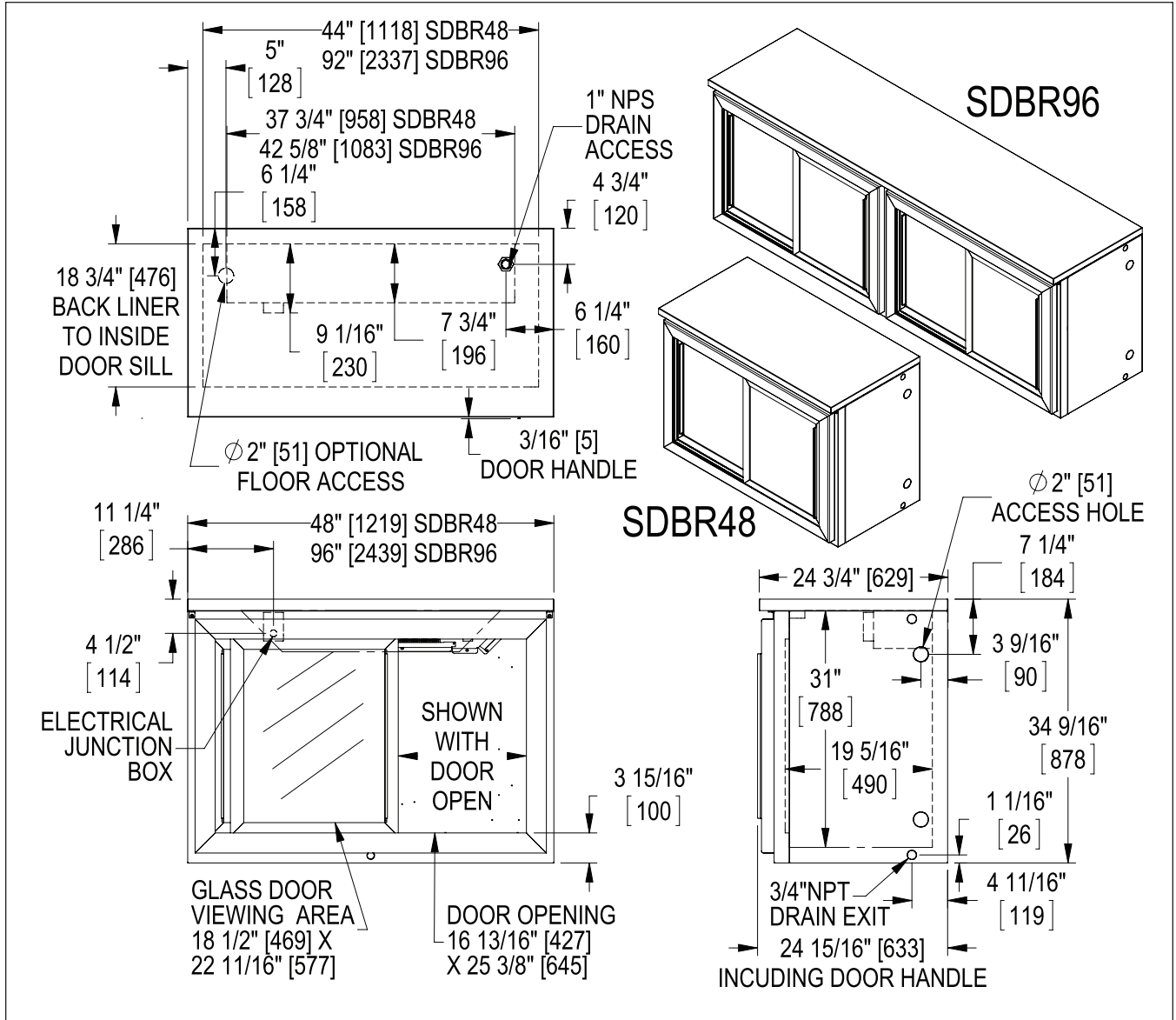

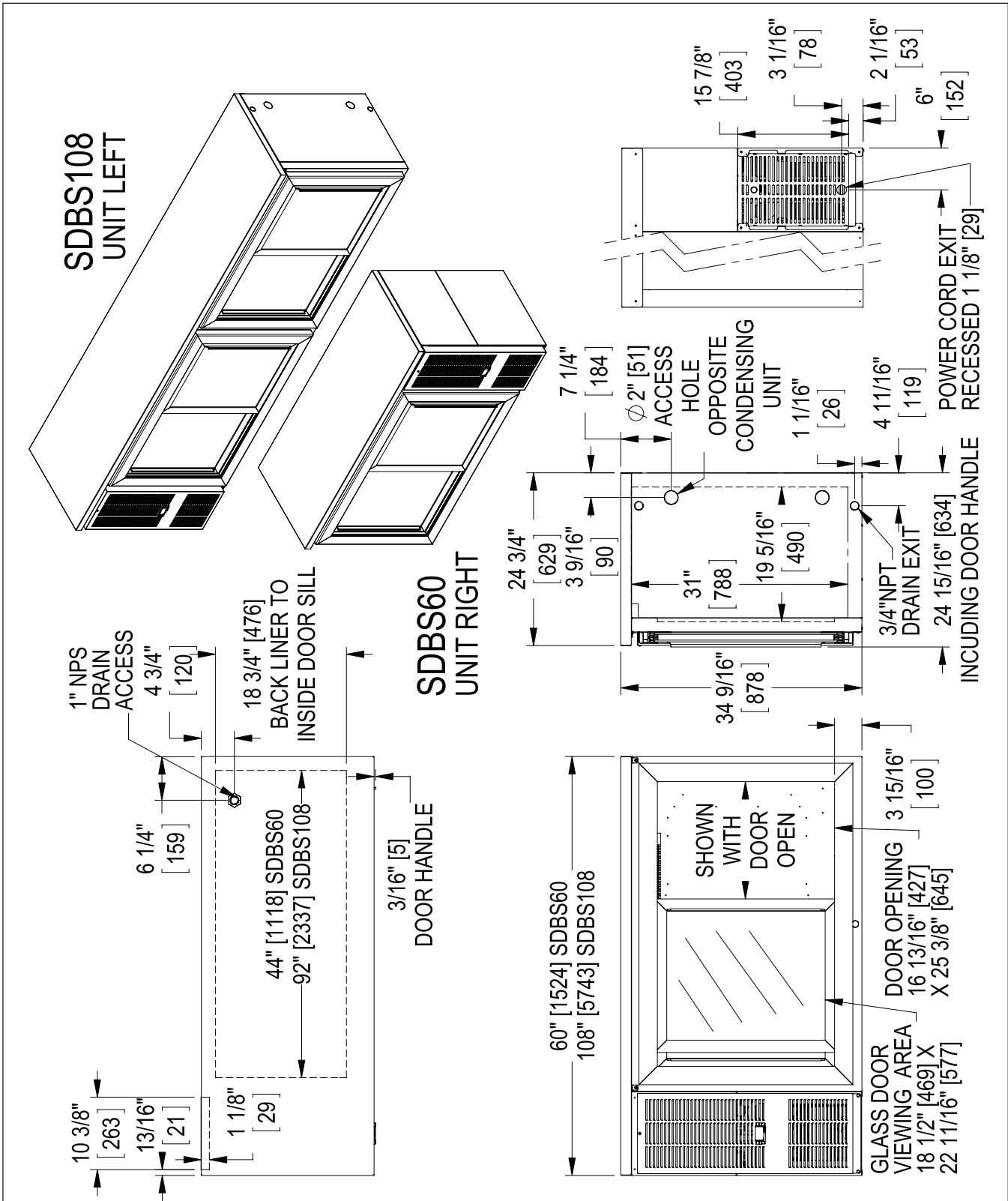

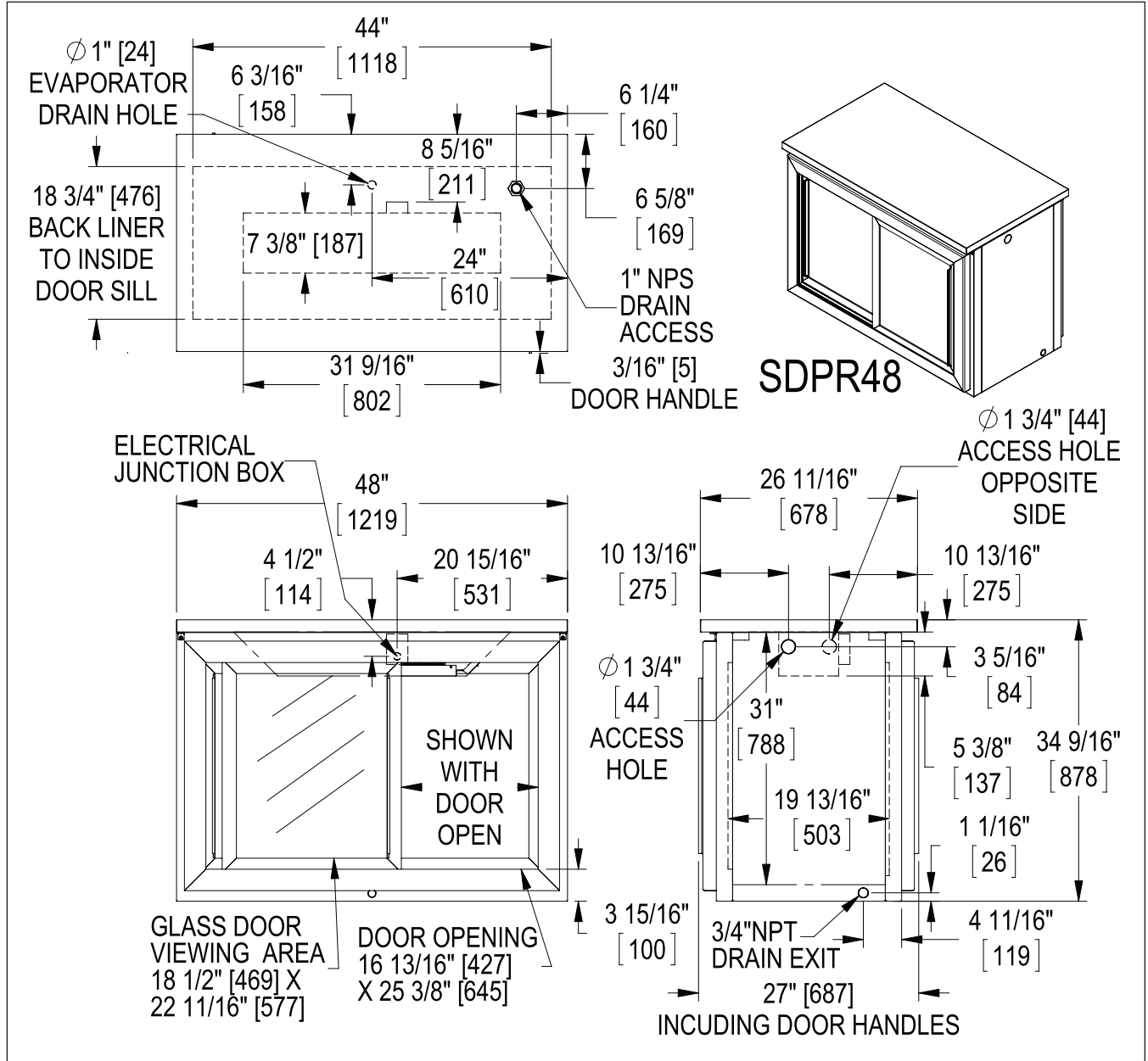

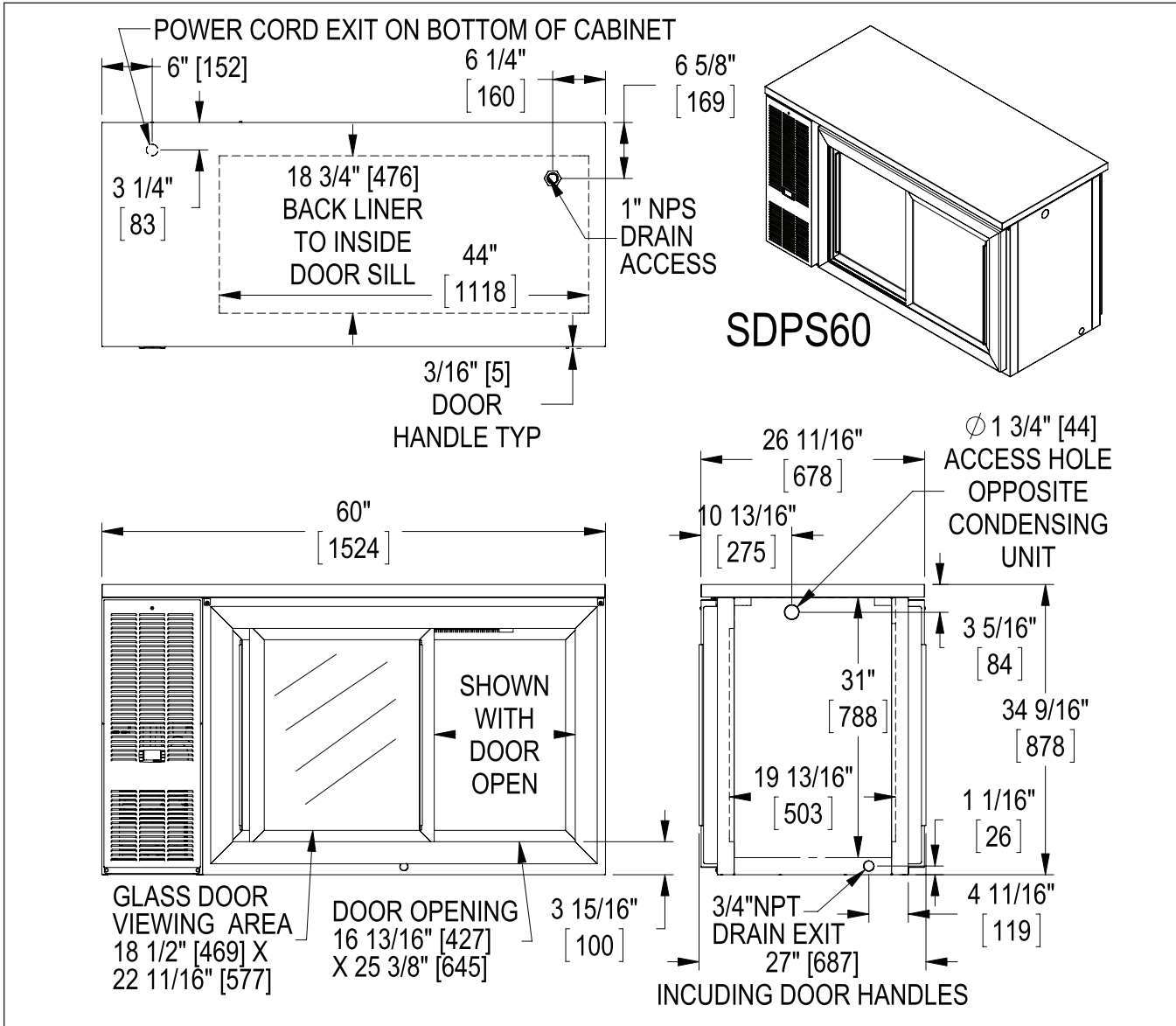

### 36" DUAL ZONE

DZS36  
UNIT LEFT  
with 4 faucet  
Tee Tower.

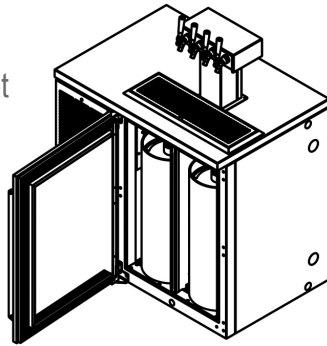

DZS36  
UNIT RIGHT  
with (2) 2 faucet  
Draft Arms.

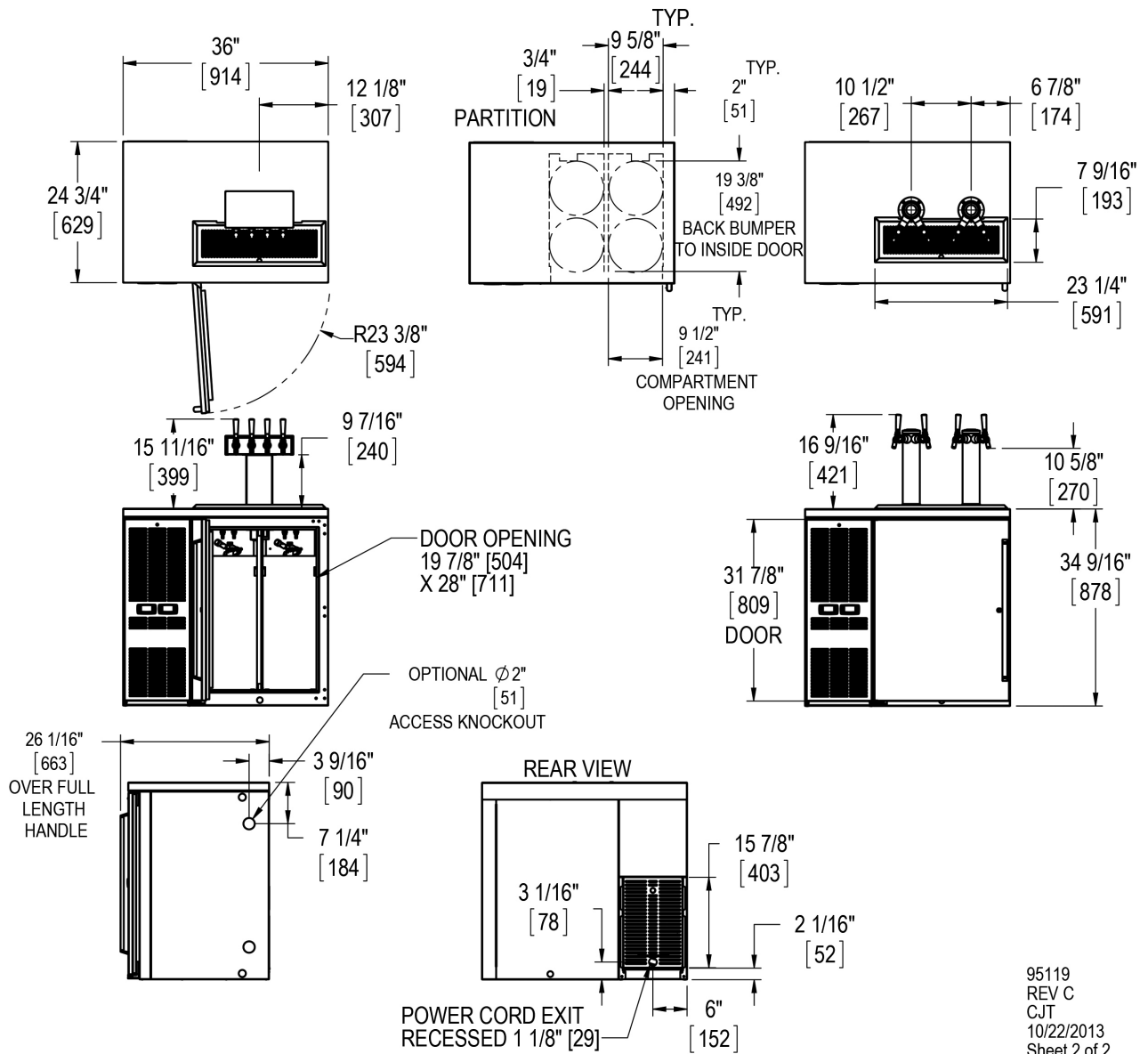
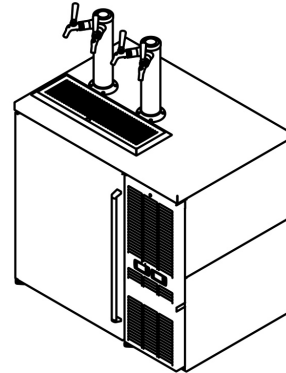

95119  
REV C  
CJT  
10/22/2013  
Sheet 2 of 2



# 60" DUAL ZONE

DZS60  
UNIT RIGHT

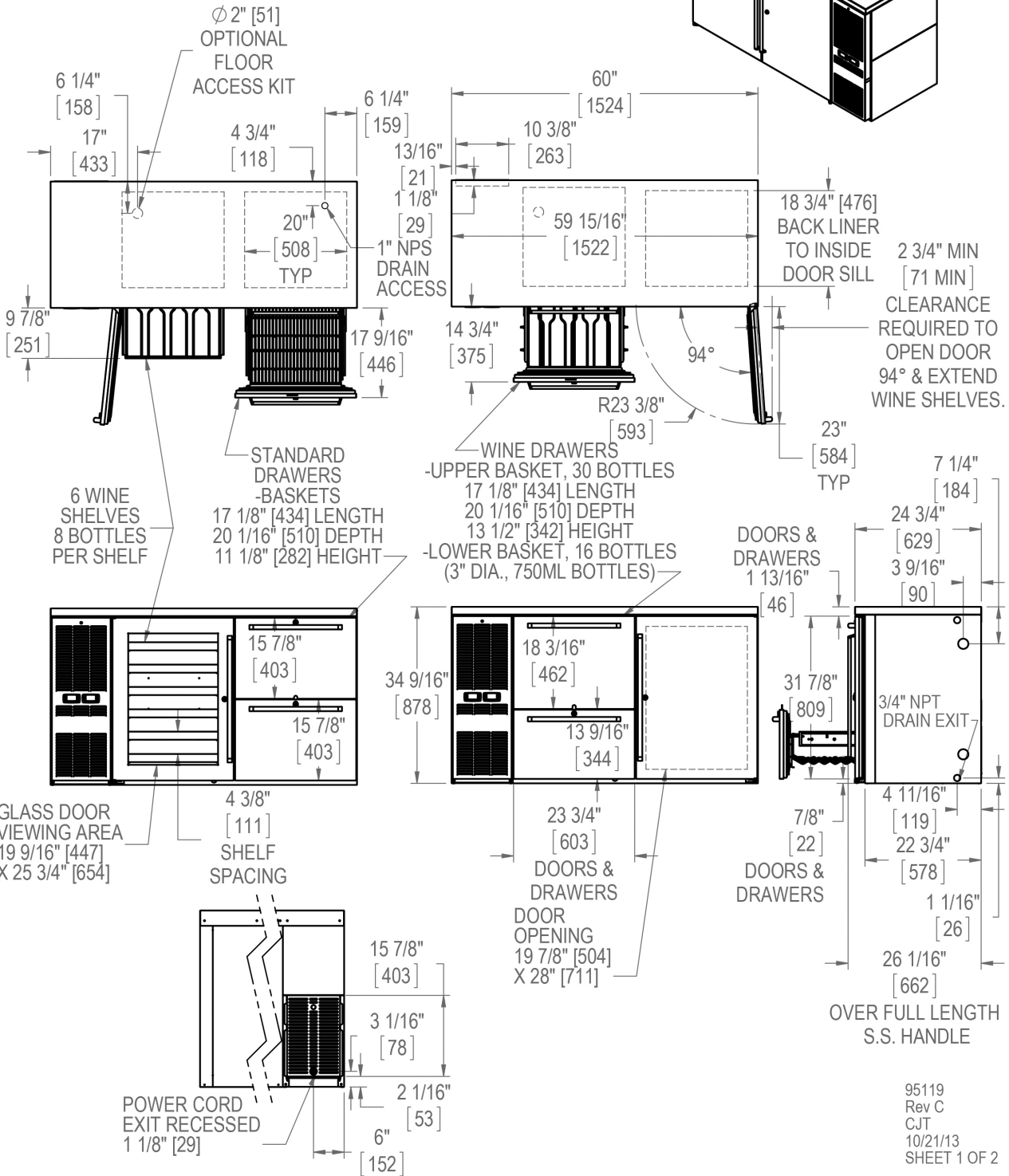
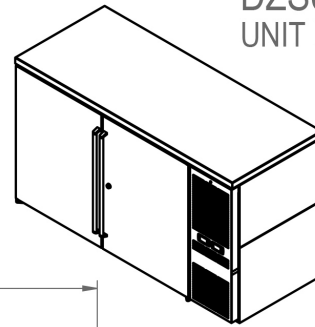

95119  
Rev C  
CJT  
10/21/13  
SHEET 1 OF 2



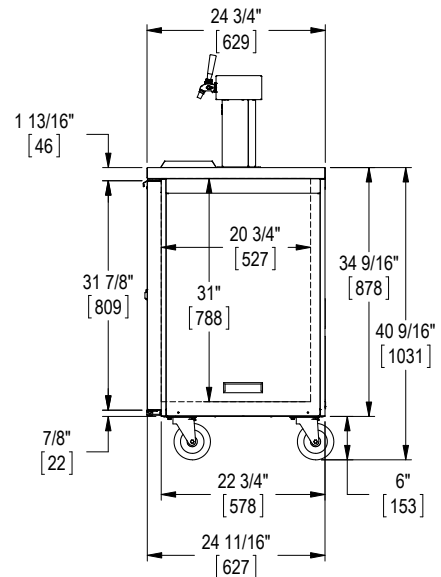
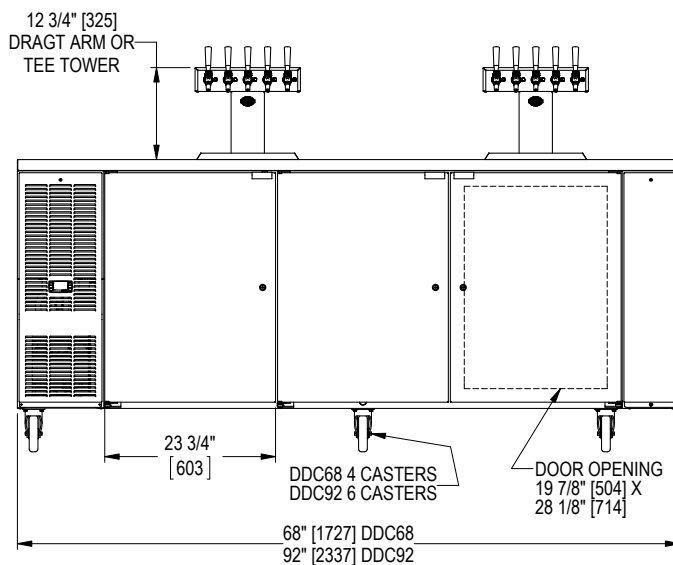
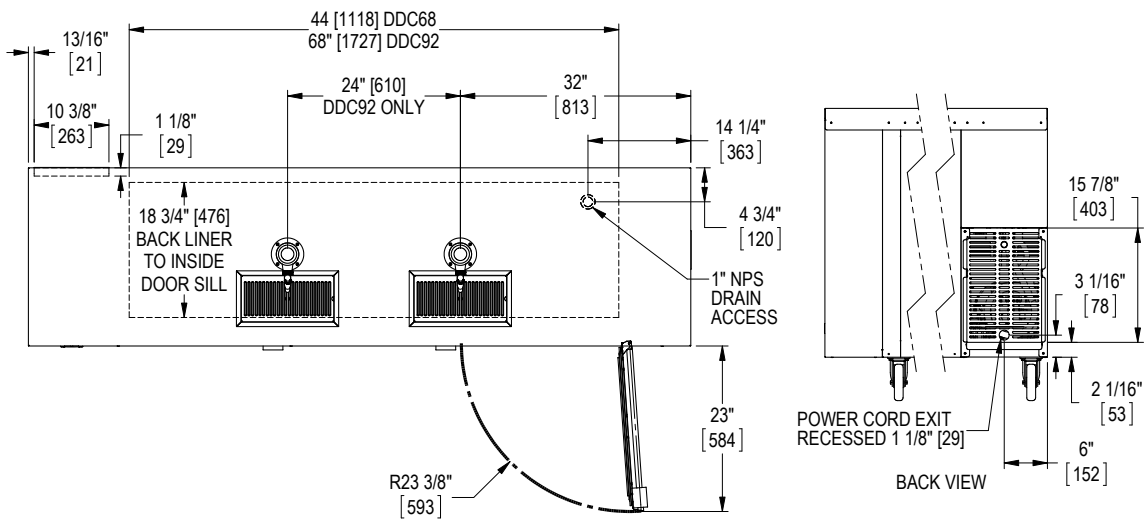
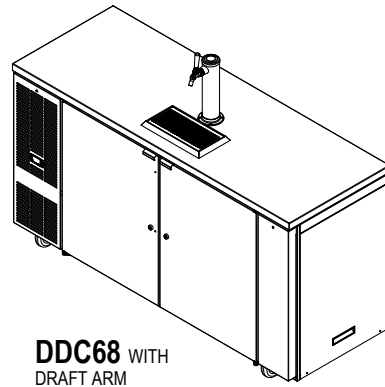
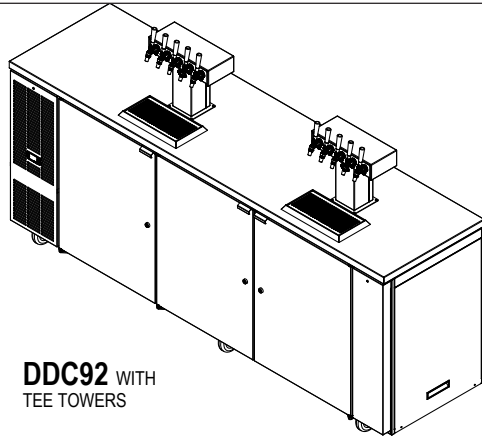

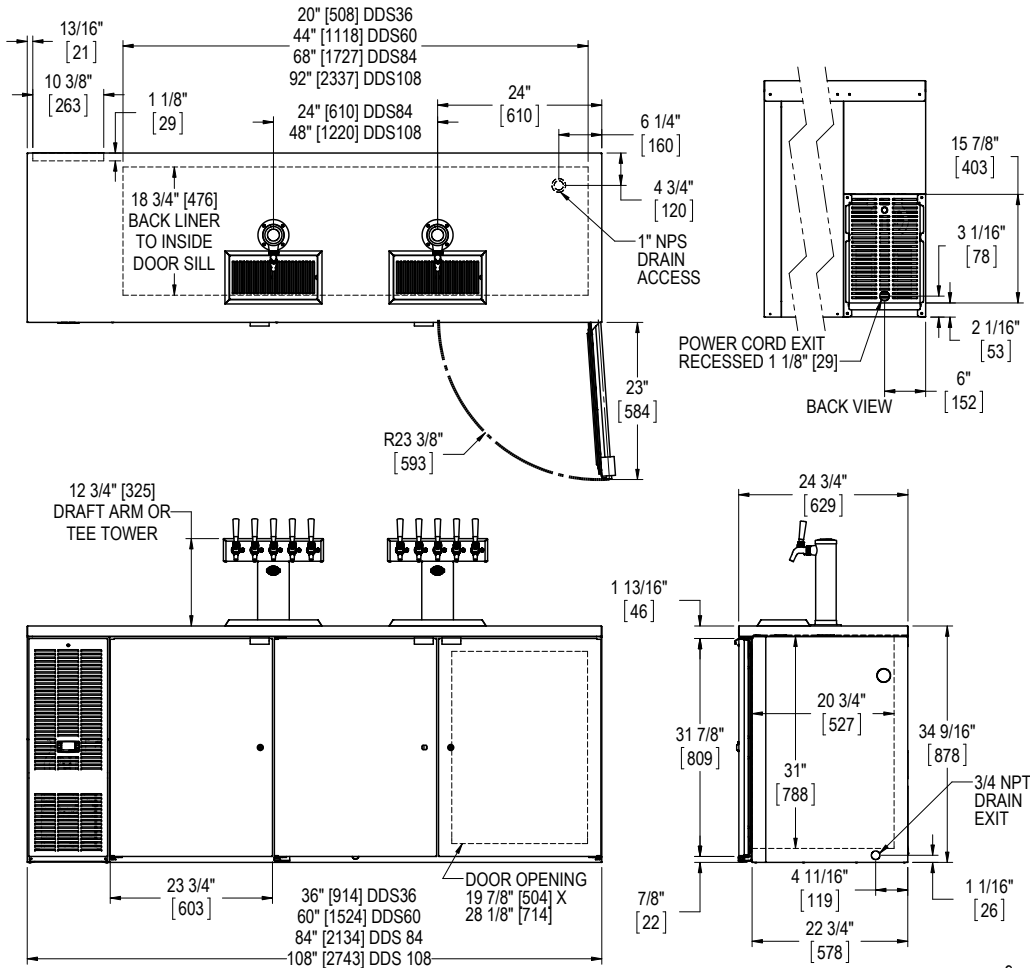
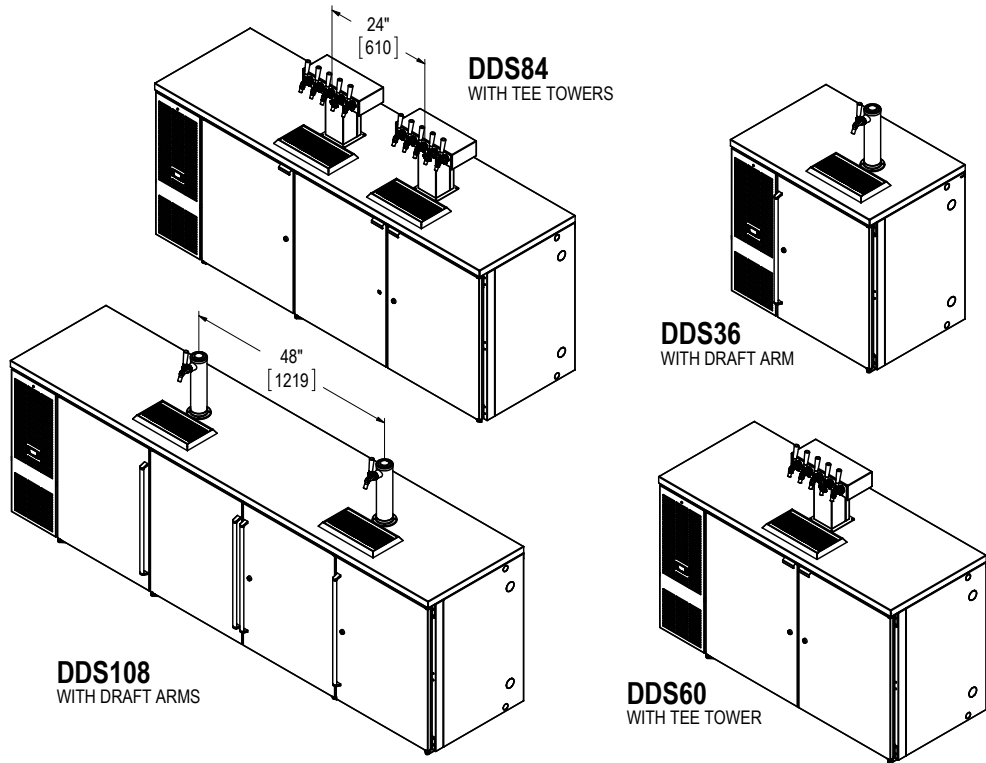

**WIRING DIAGRAMS**

**BBR24/BBRN40**  
57342A-99-120-RevA

**NOTE:**  
FIELD WIRING FROM CABINET  
JUNCTION BOX TO CONDENSING  
UNIT MUST COMPLY WITH ALL LOCAL  
AND NATIONAL ELECTRICAL CODES

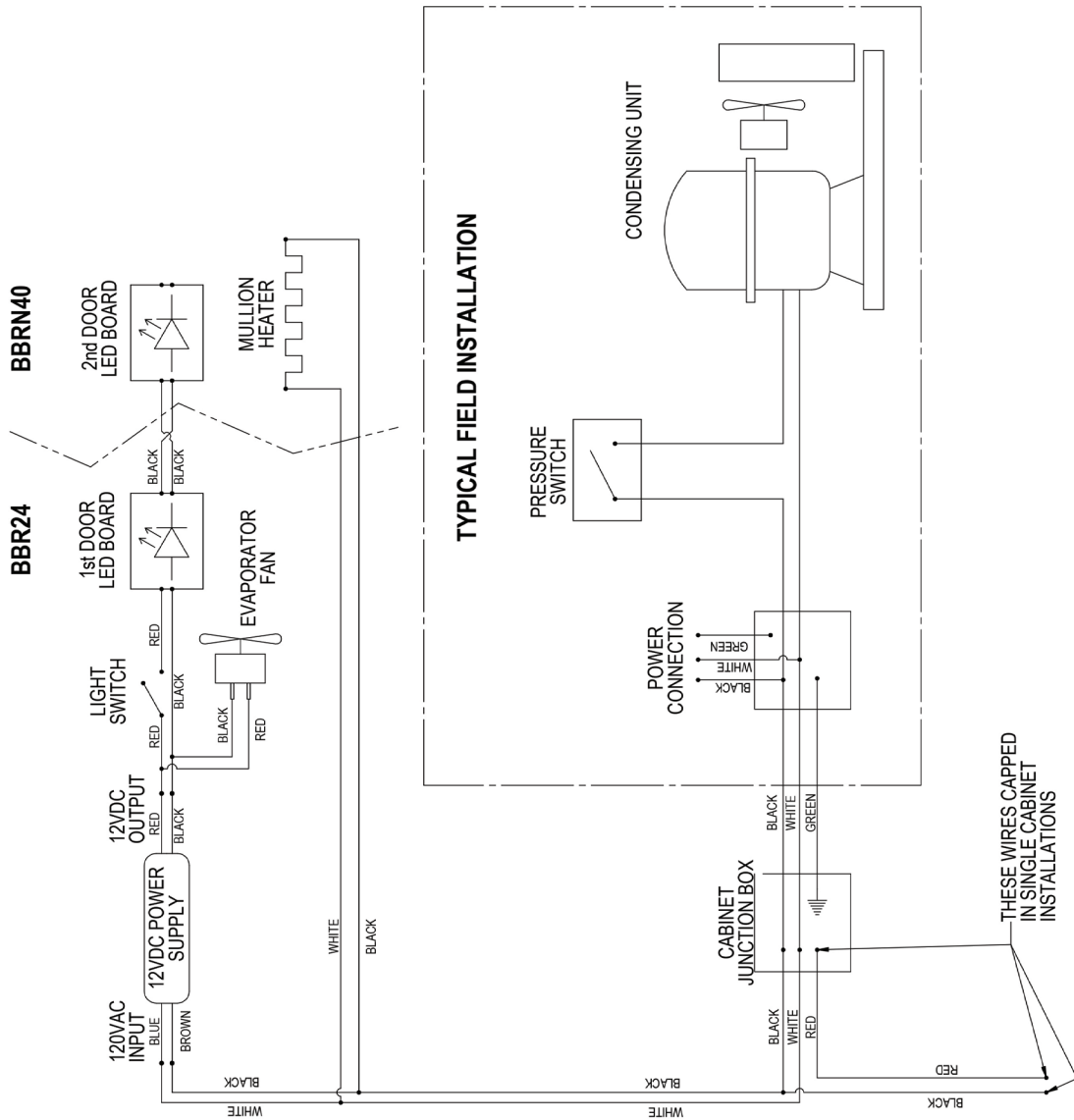

**BBR48/BBRN60/BBR72/  
BBRN80/BBR96**

57342A-98-120-RevA

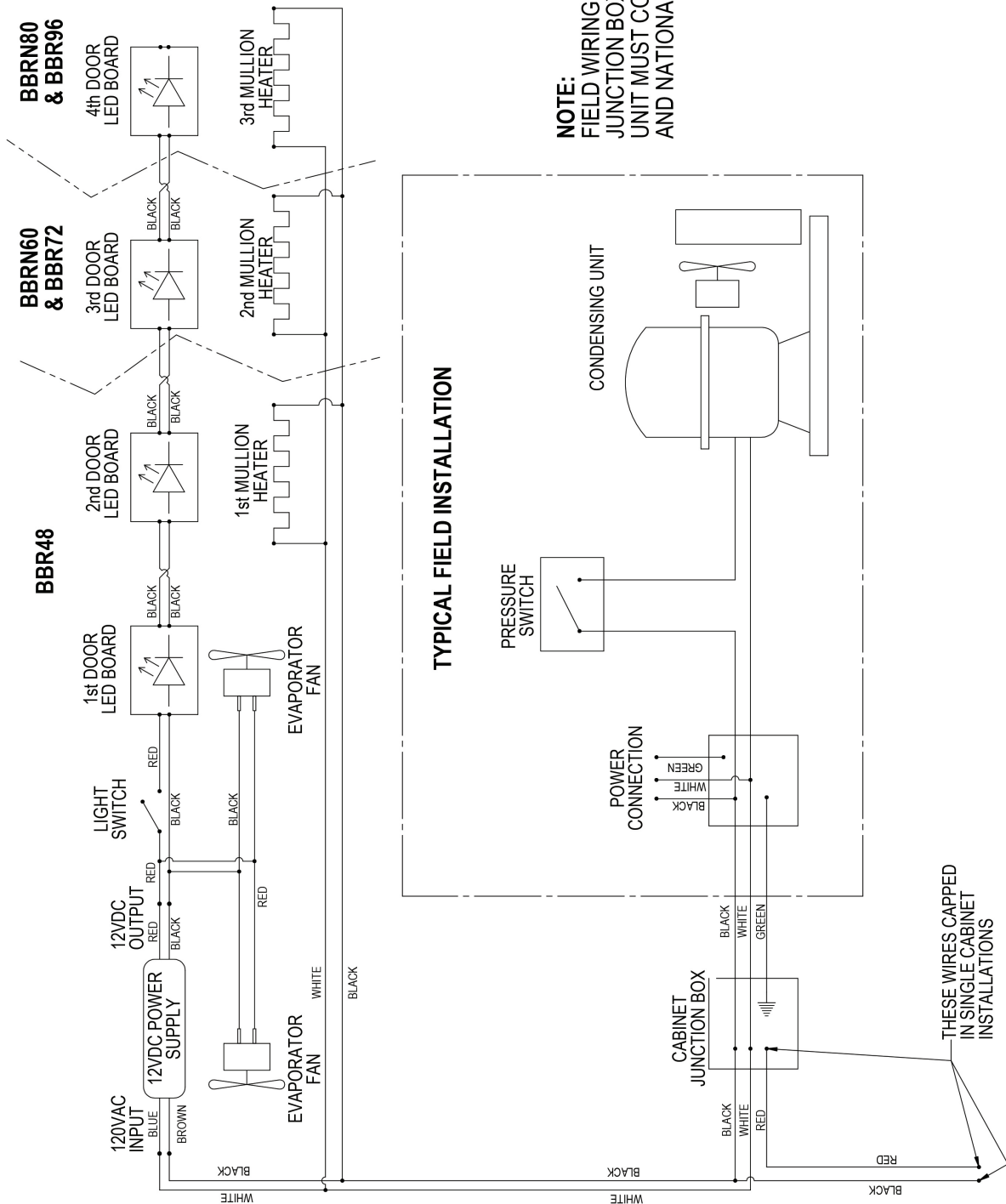

**NOTE:**  
FIELD WIRING FROM CABINET  
JUNCTION BOX TO CONDENSING  
UNIT MUST COMPLY WITH ALL LOCAL  
AND NATIONAL ELECTRICAL CODES

**TYPICAL FIELD INSTALLATION**

THESE WIRES CAPPED  
IN SINGLE CABINET  
INSTALLATIONS



**BBRLP**  
95322A-120-RevA

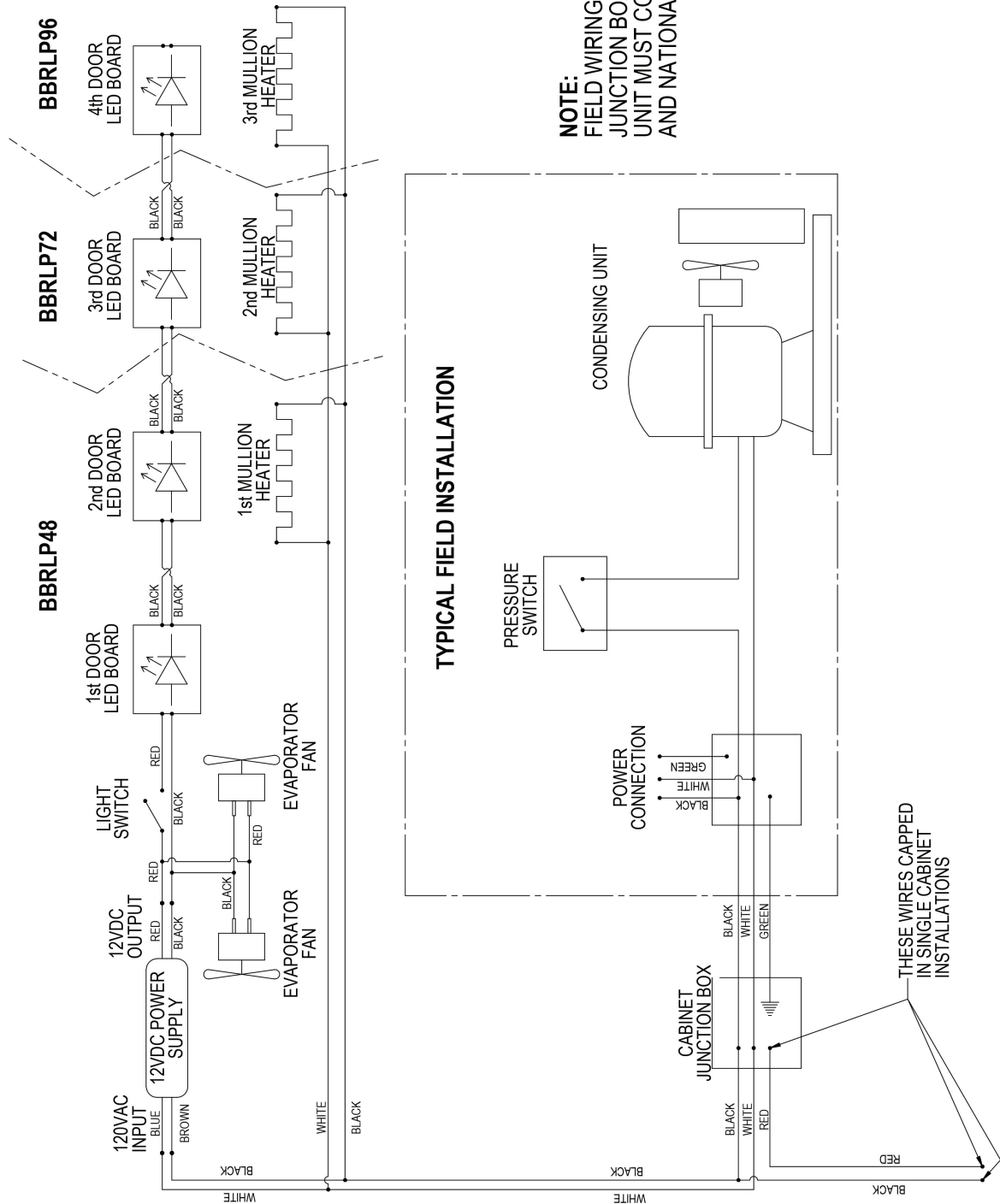

## BBS/BBSN 57342C-97-120

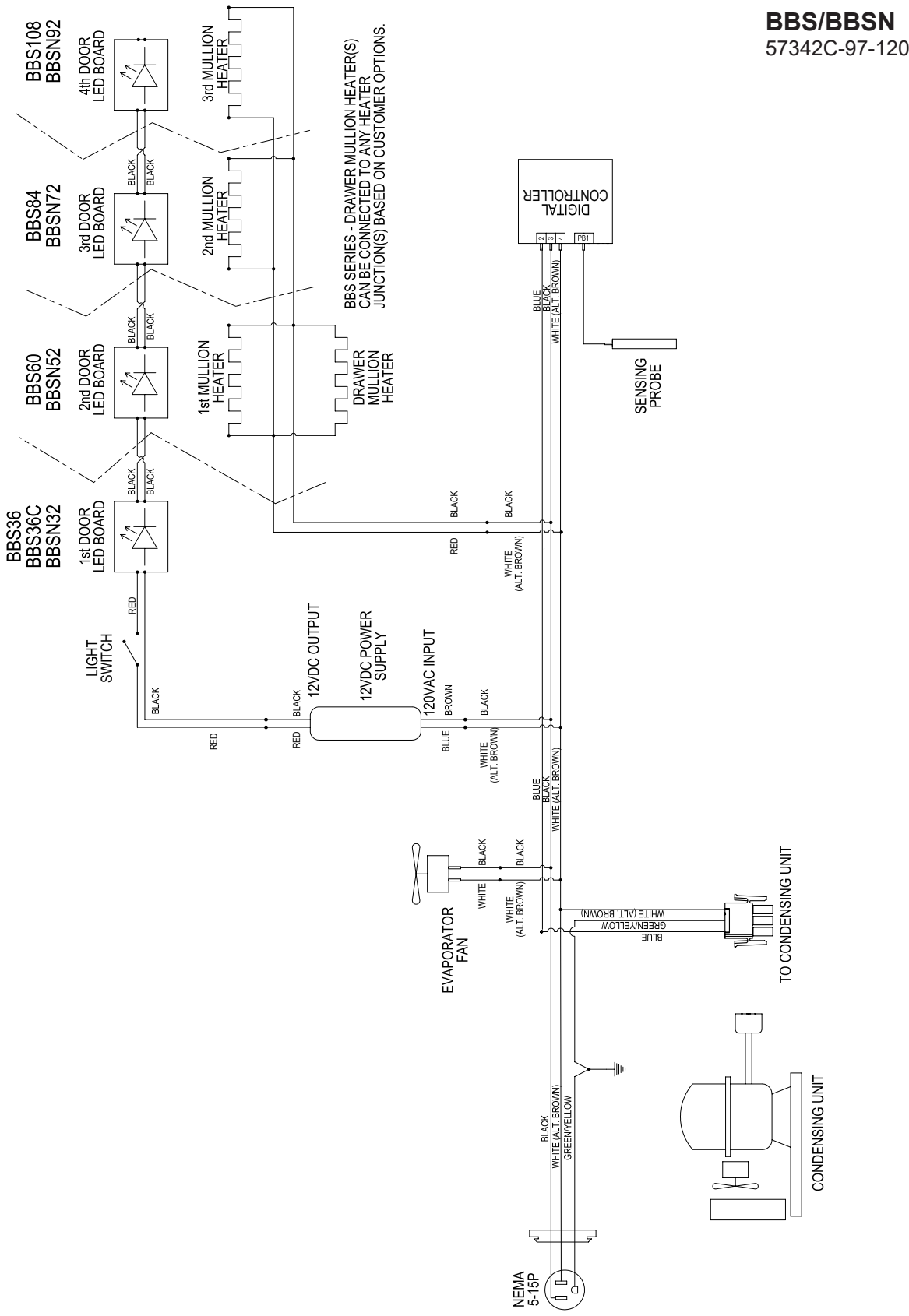

**BBSLP**  
95321C-120

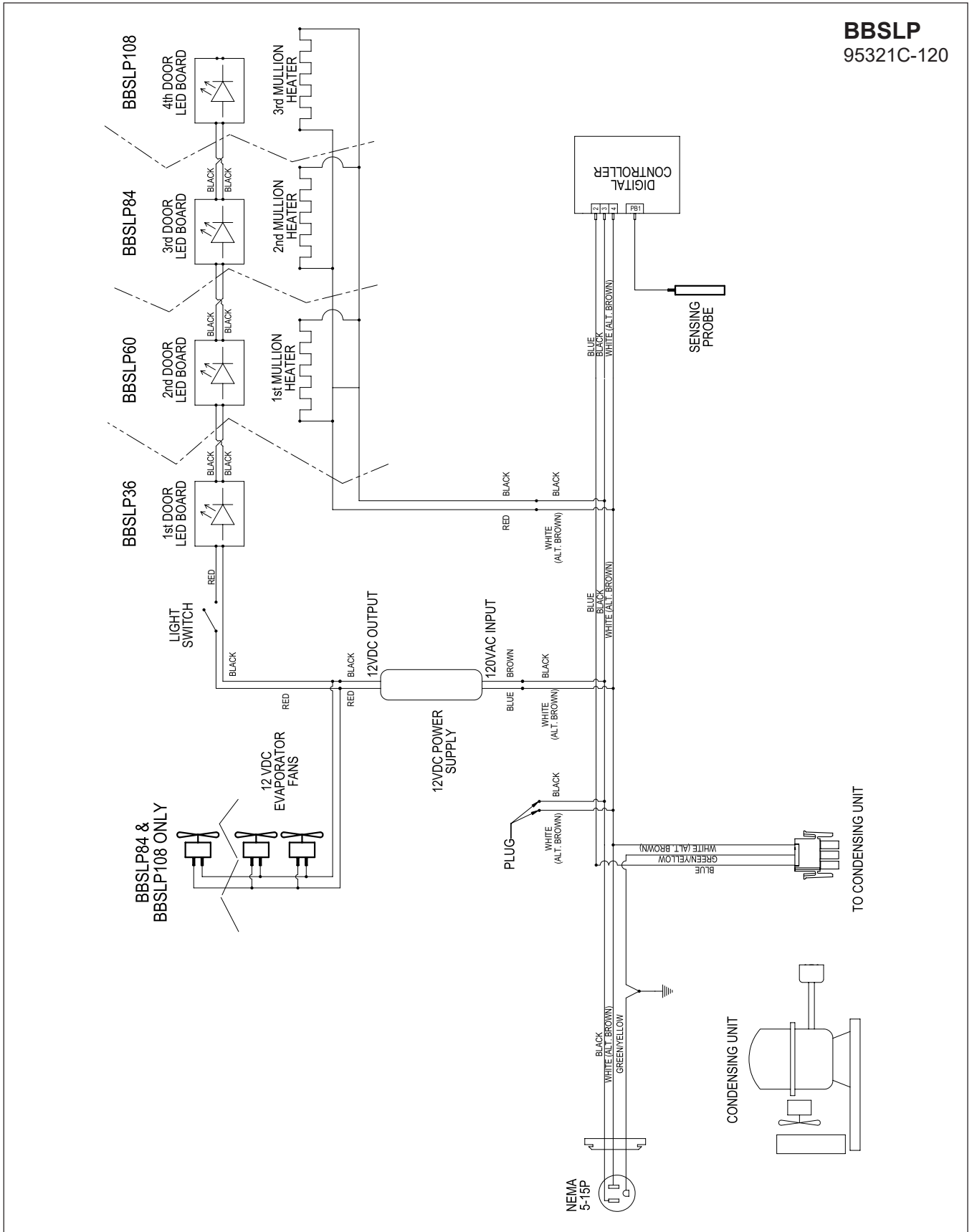

**DDS/DDC**  
57342C-100-120

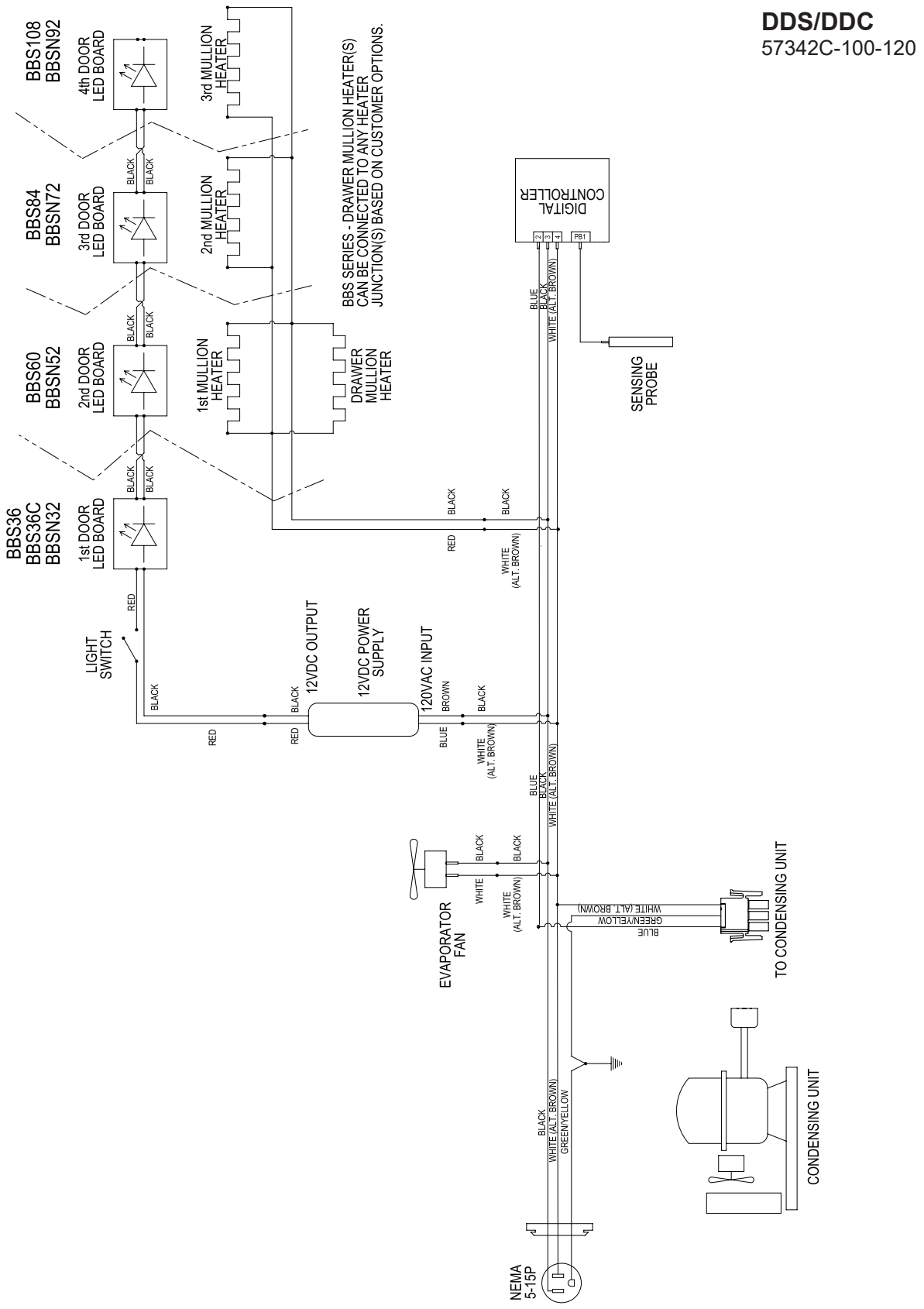



**DZS60**  
57342B-107

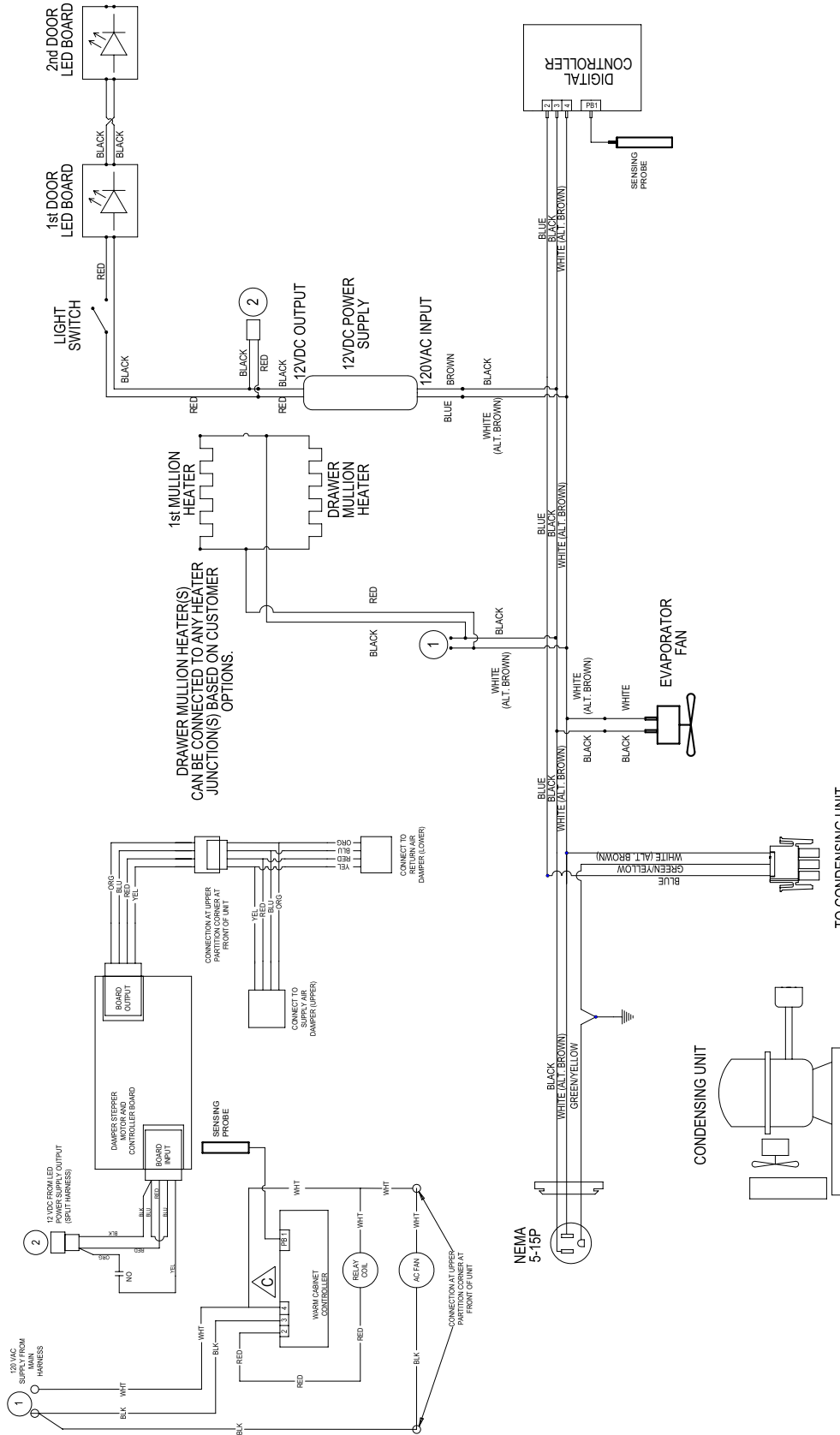

PRODUCTION START: 04/20/2020  
 PRODUCTION END: NA

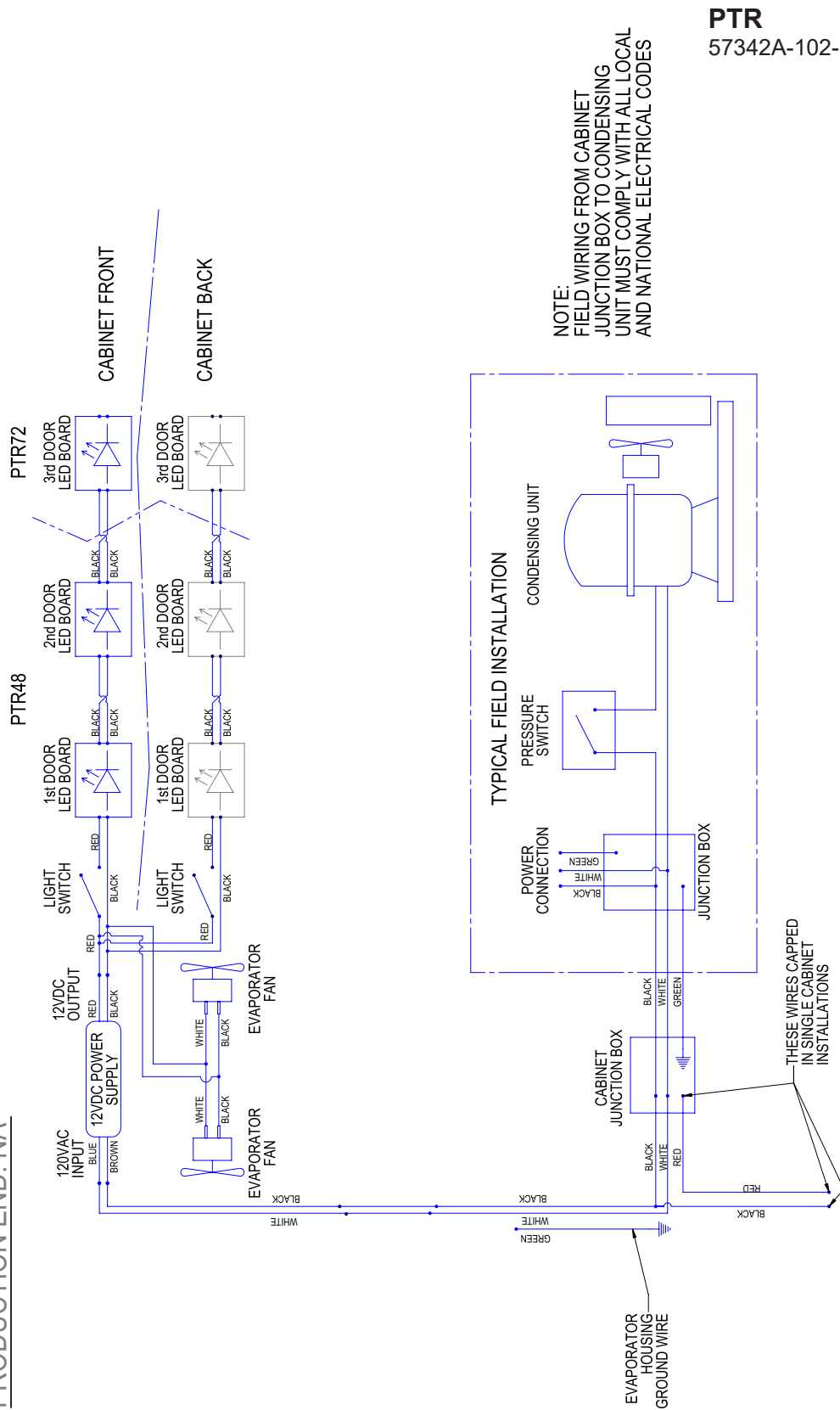

**PTR**  
 57342A-102-120-RevA

NOTE:  
 FIELD WIRING FROM CABINET  
 JUNCTION BOX TO CONDENSING  
 UNIT MUST COMPLY WITH ALL LOCAL  
 AND NATIONAL ELECTRICAL CODES

THESE WIRES CAPPED  
 IN SINGLE CABINET  
 INSTALLATIONS



PRODUCTION START: 04/20/2020  
 PRODUCTION END: NA

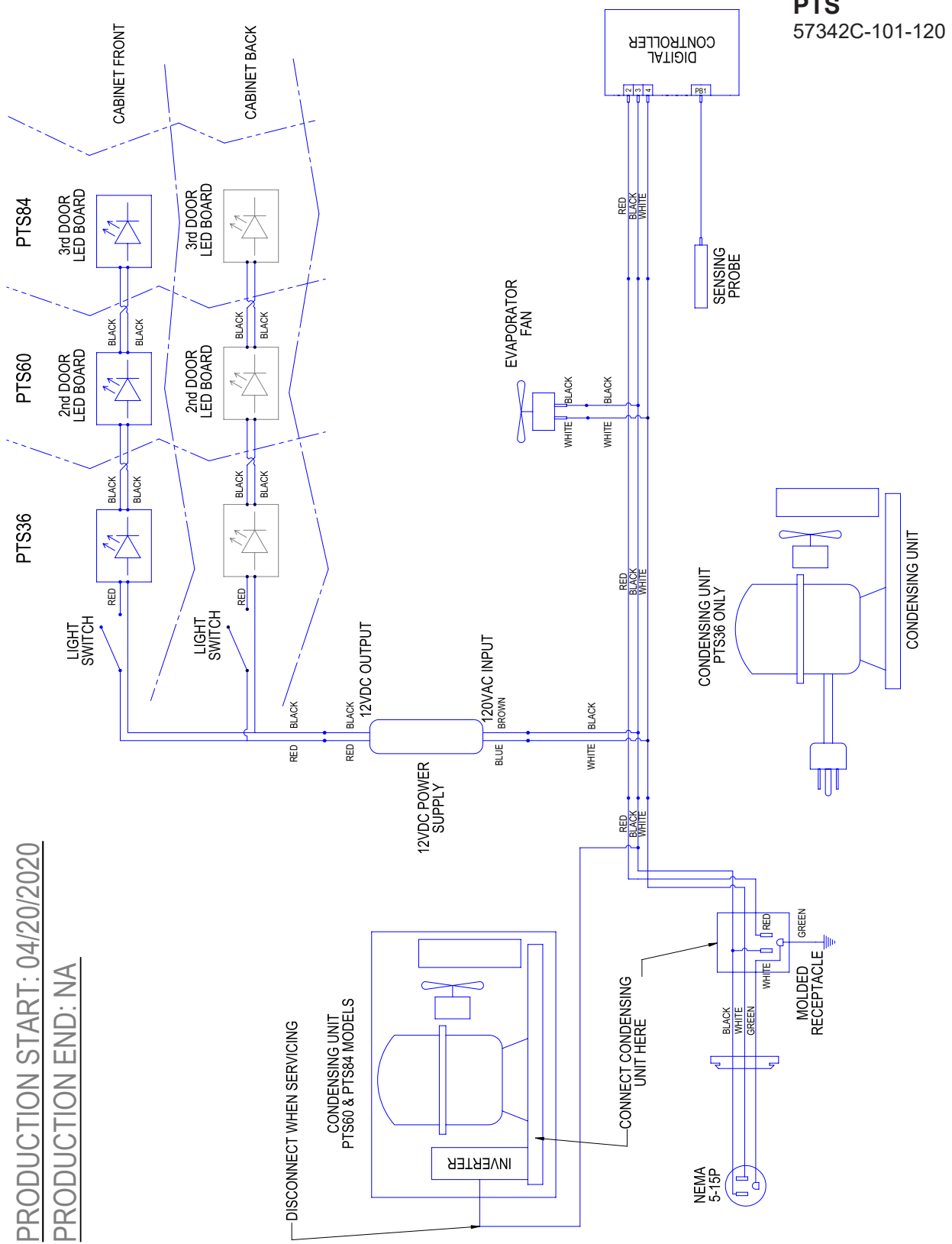

**PTS**  
 57342C-101-120



**SDBR48-SDBR96**  
57342A-106-120-RevA

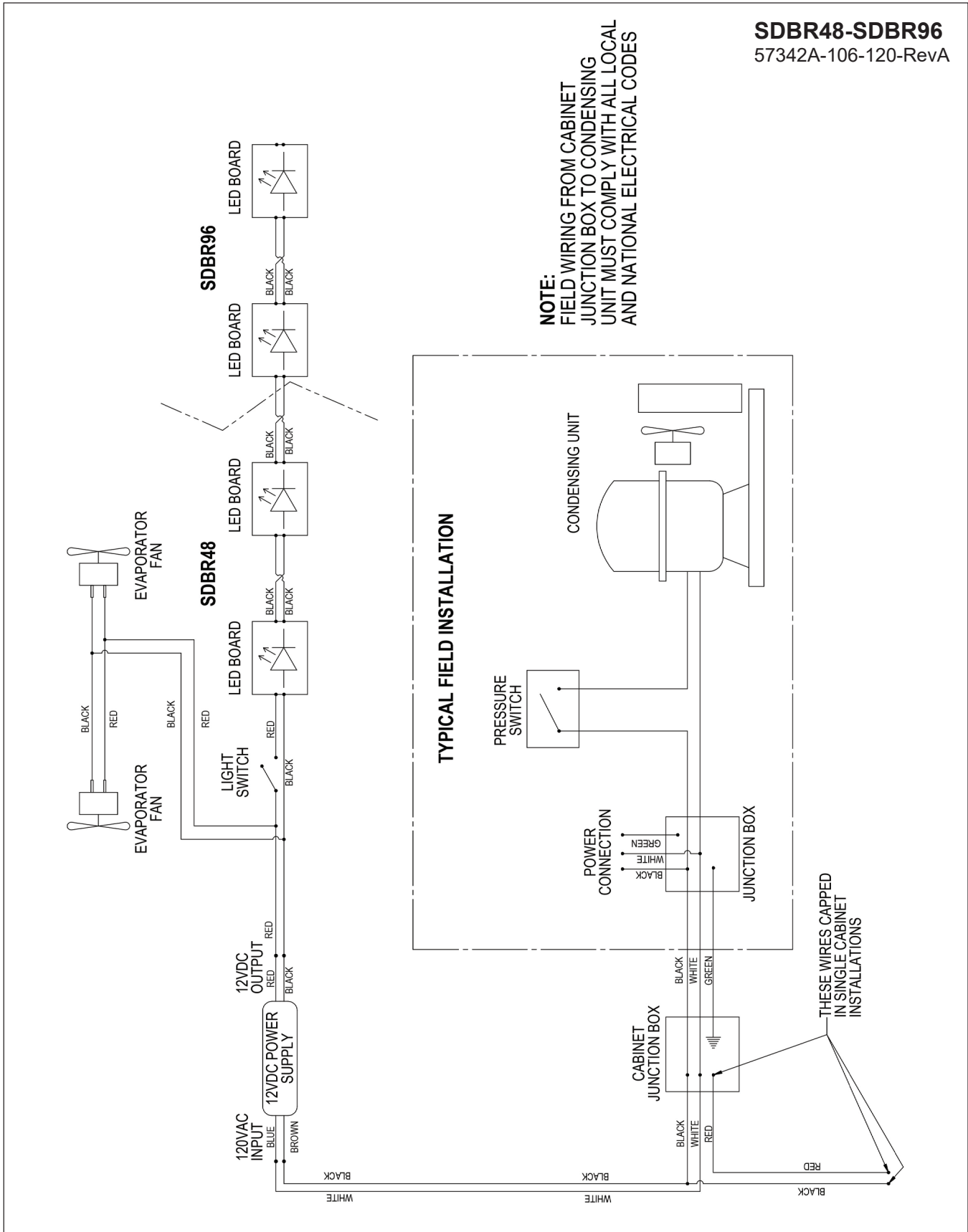

**SDBS**  
57342C-105-120

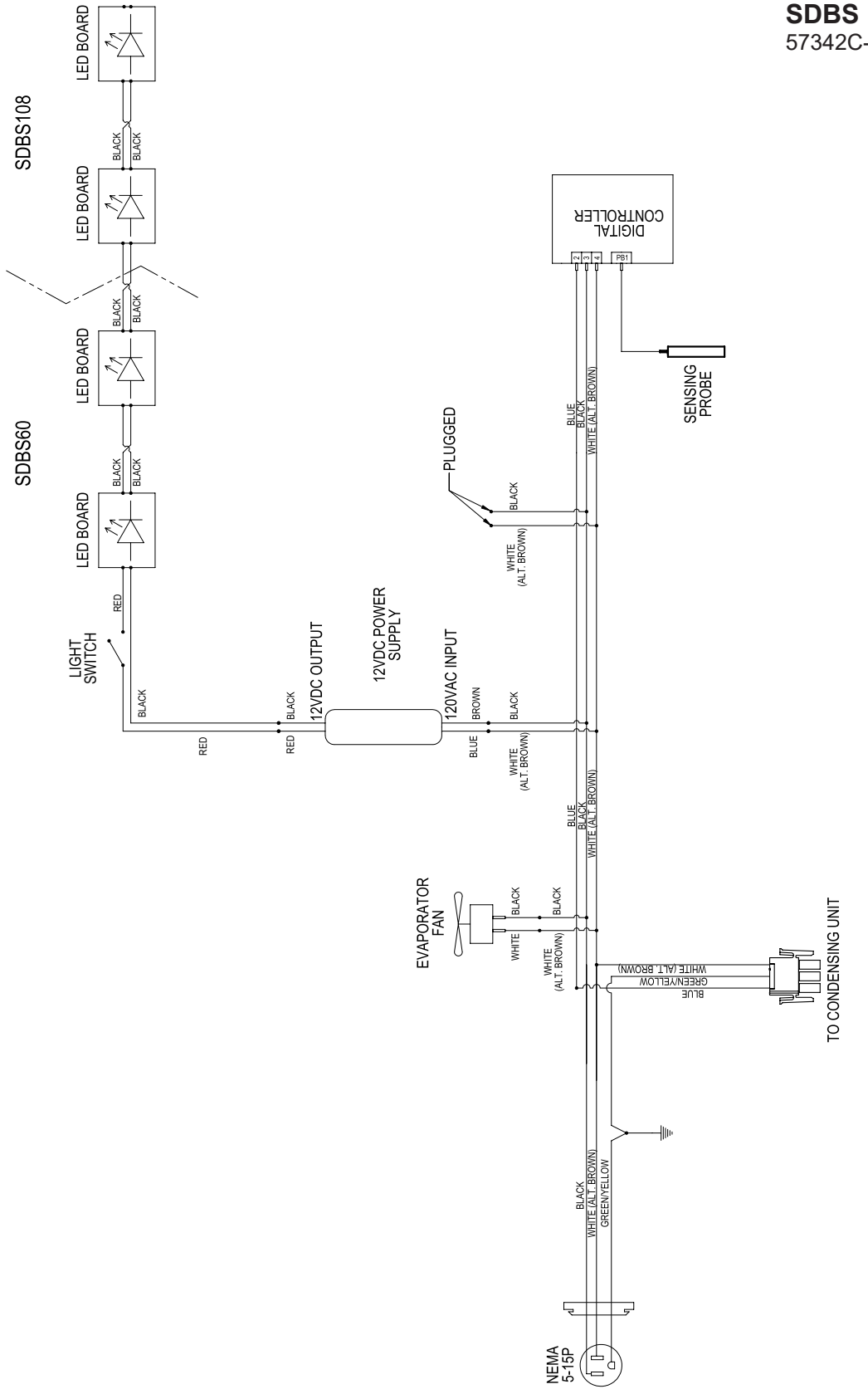

**SDPR**  
57342A-104-120-RevA

**NOTE:**  
FIELD WIRING FROM CABINET  
JUNCTION BOX TO CONDENSING  
UNIT MUST COMPLY WITH ALL LOCAL  
AND NATIONAL ELECTRICAL CODES

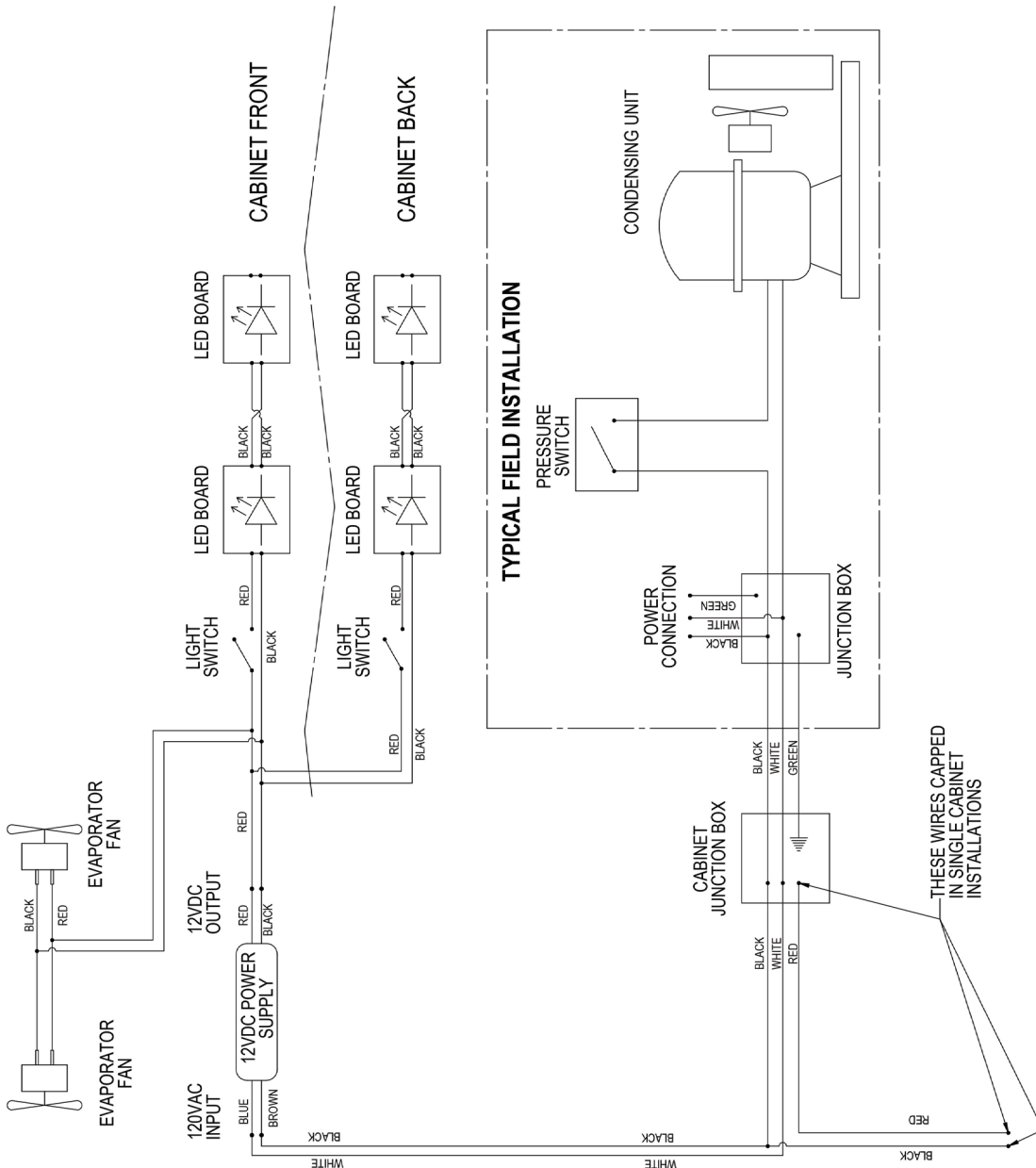

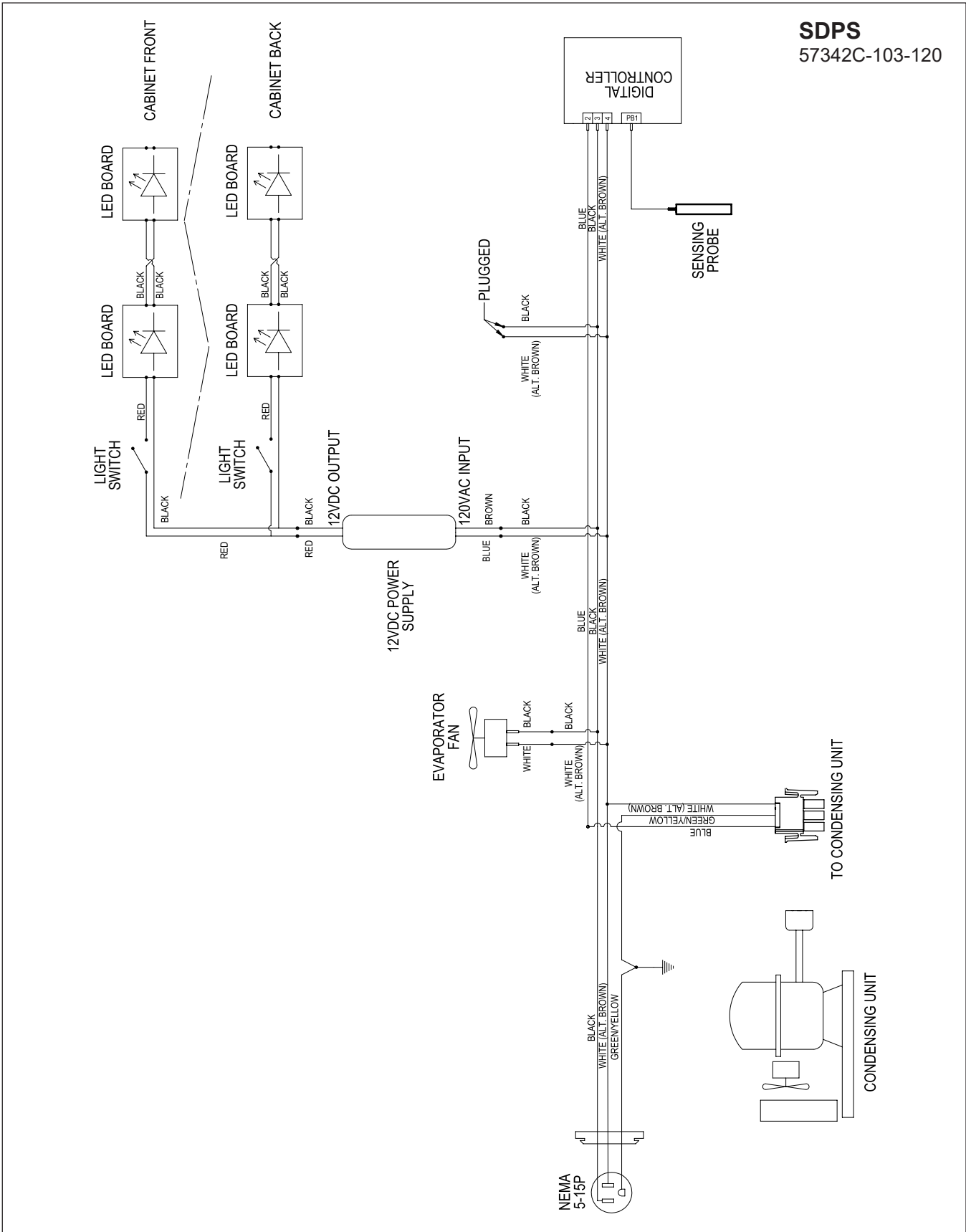

## WARRANTY

The terms and conditions set forth below together with those appearing on the face of the Acknowledgement (the "Order") constitute the complete and exclusive agreement between Perlick Corporation and the Buyer pertaining to the goods and/or services identified in the Order. If there is a discrepancy or conflict between any exhibit or supplement to the Order and these terms and conditions, these terms and conditions shall control. The Order is intended by Seller and Buyer to be the complete, exclusive, and final statement of their agreement. Any changes to an Order must be in writing and signed by Perlick and Buyer.

### TERMS NET 30 DAYS

Payment by Visa, MasterCard, American Express or Discover card accepted or cash in advance unless prior accommodations have been made with our Credit Department. Please direct inquiries for detailed information to our Credit Manager. All sales, excise, or similar taxes required by law to be collected or paid by seller shall be in addition to prices quoted unless an appropriate Tax Exemption certificate is furnished. All goods are sold F.O.B. factory. Except for otherwise provided, Perlick will not be responsible for freight, transportation, insurance, shipping, storage, handling, demurrage or similar charges. Invoices are payable in full in thirty (30) days following the invoice's date of issuance. If by the terms of sale credit is extended, Perlick reserves the right to revoke such credit if buyer fails to pay for any products when due and may demand payment prior to the commencement of any further shipment.

### WAIVER

Any waiver of strict compliance with the provisions of an Order must be in writing. No such waiver shall be construed as a waiver of any other term or condition except as provided in writing, nor as a waiver of any subsequent breach of the same term or condition.

### METHOD OF SHIPMENT

All shipments are carefully packed and labeled. Crates, boxes and cartons used are of approved weight and strength. Freight rates are based upon 100 pound minimum.

### LOST and DAMAGED MERCHANDISE

THE RESPONSIBILITY OF THE PERLICK CORPORATION CEASES UPON ACCEPTANCE OF ITS PRODUCTS BY THE CARRIER. Any damage or loss sustained in shipment is the carrier's responsibility. Before giving the carrier a clean receipt at time of delivery, make sure you receive every item on the bill and inspect every carton, crate and box for concealed damage, i.e., broken boards, crushed or punctured cartons, torn cardboard. IF ANY ITEMS ARE SHORT OR DAMAGED, DO NOT ACCEPT THE SHIPMENT UNLESS THE CARRIER MAKES A NOTATION OF THIS ON YOUR FREIGHT BILL. Then request an inspection. Do not destroy the packing materials. If their agent does not make an inspection within five days, advise the carrier via letter that you notified them regarding the matter and they have failed to act. You will need this letter to support your claim. Then file a claim for your loss. When you give the carrier a clean receipt, you accept the total responsibility for the shipment. UPS shipments are insured individually and UPS will replace all merchandise that is lost or damaged.

### RETURN OF MERCHANDISE

Do not return any merchandise without our approval. Merchandise returned without a return merchandise authorization number will not be accepted at Perlick. Used, discontinued, and certain custom made items cannot be returned for credit. These custom items include non-catalog products (specials) as well as custom assembled catalog products. Catalog items are designated as non-returnable on the price list page on which they appear. Items returned must be in new condition and packaged in their original carton or crate. Freight charges must be prepaid on all return shipments.

When a return is authorized, a credit may be allowed pending an examination of the returned goods. The amount of the restocking charge will depend on the condition of the equipment. The minimum restocking charge for glass washers, bottle coolers, frosters, direct draws, cooler series back bars and accessory parts is 20%. The minimum restocking charge for custom series cabinets is 50%. The minimum restocking charge for un-assembled, freestanding underbar stainless steel modules is 20%. Assembled under bar modules are considered custom products and are not returnable for credit. The restocking charge on the item returned is either a percentage of the value of the item or \$35.00, whichever is greater.

### **ONE YEAR PARTS WARRANTY**

Perlick products are guaranteed against defects in both material and workmanship for a period of one year from date of sale. Defective parts will be replaced on a no-charge basis, F.O.B. our factory, when adjudged defective upon inspection. We are not responsible for parts damaged by alteration, unauthorized service, accident or abuse. All costs associated with replacement, including freight, labor and/or loss of sales, are the responsibility of the user.

### **ONE YEAR LABOR WARRANTY**

In addition to Perlick's one year parts warranty and five year compressor warranty, ALL PERLICK REFRIGERATION SYSTEMS are offered with a one year labor warranty at no extra charge. Perlick's one year labor warranty provides that Perlick will pay for the cost of any labor to replace any defective part for up to one year after installation, subject to the following terms and conditions:

- (A) Parts returned to Perlick shall be returned freight prepaid and shall be identified with Perlick's serial number and return authorization number.
- (B) Improper operation due to voltage variances, inadequate wiring and physical damage is the responsibility of the purchaser. They are not manufacturing defects.
- (C) Condenser coils shall be cleaned regularly. Failure to provide an adequate flow of cooling air will void this warranty.
- (D) Factory-specified maintenance and installation will be provided by the selling dealer who shall also be responsible for the installation and set-up of these products in accordance with local plumbing, refrigeration and electrical codes.

Perlick's one year labor policy applies to the United States and Canada. IT DOES NOT APPLY TO REFRIGERATION SYSTEMS ADDED BY OTHERS (remote systems) or any part which has been subject to misuse, neglect, alteration, accident, or to any damage caused by transportation, flood, fire or other acts of God.



**NOTES**





**NOTES**



Form No. Z2604  
Rev A 06.27.2022



Z2604

8300 West Good Hope Road • Milwaukee, WI 53223 •

Toll Free 800.558.5592 • Fax 414.353.7069 • [www.perlick.com](http://www.perlick.com)