

Operator's Manual

CRAFTSMAN®

4-Cycle

Electric Start Capable

WEEDWACKER® GAS TRIMMER

Model No. 316.731971



INCREDI-PULL™
UNBELIEVABLE STARTING EASE™

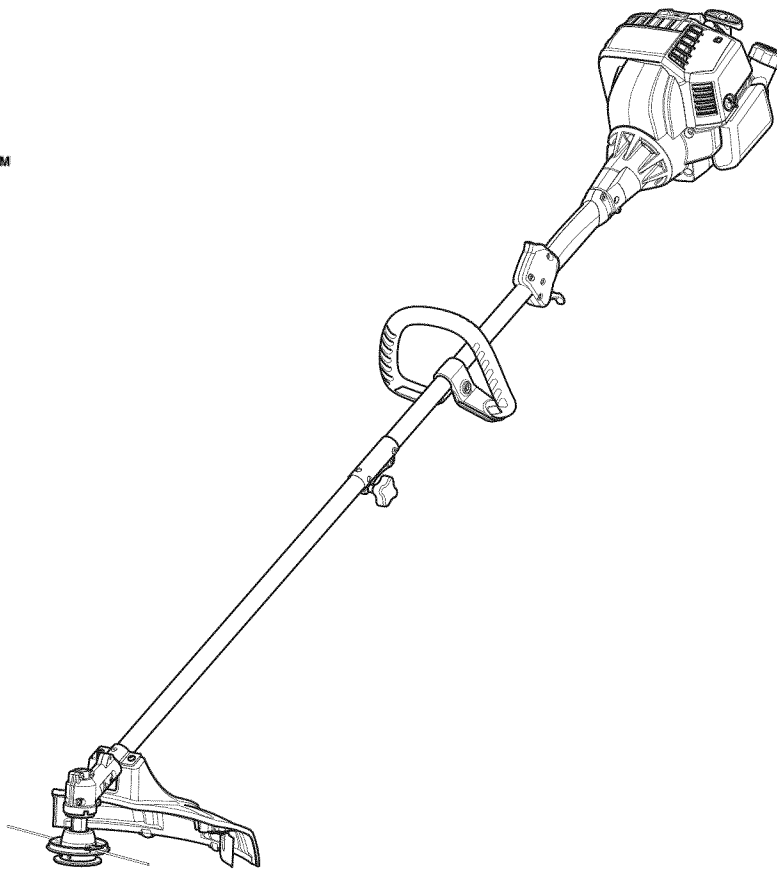

CAUTION: Before using this product, read this manual and follow all its Safety Rules and Operating Instructions.

- SAFETY
- ASSEMBLY
- OPERATION
- MAINTENANCE
- ESPAÑOL, P. 19

Sears Brands Management Corporation, Hoffman Estates, IL 60179 U.S.A.

Visit our website: www.craftsman.com

TABLE OF CONTENTS

Safety	2
Warranty	5
Know Your Unit	6
Specifications	6
Assembly	7
Oil and Fuel	9
Starting and Stopping	10
Operation	12
Maintenance	13
Cleaning and Storage	16
Troubleshooting	17
Repair Protection Agreements	18
Service Numbers	Back Cover

All information, illustrations and specifications in this manual are based on the latest product information available at the time of printing. We reserve the right to make changes at any time without notice.

© Sears Brands, LLC

SAFETY

The purpose of safety symbols is to attract your attention to possible dangers. The safety symbols, and their explanations, deserve your careful attention and understanding. The safety warnings do not by themselves eliminate any danger. The instructions or warnings they give are not substitutes for proper accident prevention measures.

SYMBOL MEANING

 **DANGER:** Signals an **EXTREME** hazard. Failure to obey a safety **DANGER** signal **WILL** result in serious injury or death to yourself or to others.

 **WARNING:** Signals a **SERIOUS** hazard. Failure to obey a safety **WARNING** signal **CAN** result in serious injury to yourself or to others.

 **CAUTION:** Signals a **MODERATE** hazard. Failure to obey a safety **CAUTION** signal **MAY** result in property damage or injury to yourself or to others.

NOTE: Advises you of information or instructions vital to the operation or maintenance of the equipment.

SPARK ARRESTOR NOTE

NOTE: For users on U.S. Forest Land and in the states of California, Maine, Oregon and Washington. All U.S. Forest Land and the state of California (Public Resources Codes 4442 and 4443), Oregon and Washington require, by law that certain internal combustion engines operated on forest brush and/or grass-covered areas be equipped with a spark arrestor, maintained in effective working order, or the engine be constructed, equipped and maintained for the prevention of fire. Check with your state or local authorities for regulations pertaining to these requirements. Failure to follow these requirements could subject you to liability or a fine. **This unit is factory equipped with a spark arrestor.** If it requires replacement, contact a Sears Parts & Repair Service Center to install the appropriate muffler assembly.

 **CALIFORNIA PROPOSITION 65**
WARNING: Engine exhaust, some of its constituents and certain finished components contain or emit chemicals known to the State of California to cause cancer and birth defects or other reproductive harm. Wash hands after handling.

Read the operator's manual and follow all warnings and safety instructions. Failure to do so can result in serious injury to the operator and/or bystanders.

• IMPORTANT SAFETY INSTRUCTIONS •

READ ALL INSTRUCTIONS BEFORE OPERATING



WARNING: When using the unit, all safety rules must be followed. Please read these instructions before operating the unit in order to ensure the safety of the operator and any bystanders. Please keep these instructions for later use.

- Read the instructions carefully. Be familiar with the controls and proper use of the unit.
- Do not operate this unit when tired, ill or under the influence of alcohol, drugs or medication.
- Children must not operate the unit. Teens must be accompanied and guided by an adult.
- All guards and safety attachments must be installed properly before operating the unit.
- Inspect the unit before use. Replace damaged parts. Check for fuel leaks. Make sure all fasteners are in place and secure. Replace parts that are cracked, chipped, or damaged in any way. Do not operate the unit with loose or damaged parts.
- Only use the trimming line described in the *Specifications* section of this manual. Never use metal-reinforced line, wire, chain or rope. These can break off and become dangerous projectiles.
- Do not replace the cutting head with rigid or metal blades. Doing so could result in serious injury.
- Be aware of risk of injury to the head, hands and feet.
- Carefully inspect the area before starting the unit. Remove rocks, broken glass, nails, wire, string and other objects that may be thrown or become entangled with the unit.
- Clear the area of children, bystanders and pets; keep them outside a 50-foot (15 m) radius, at a minimum. Even then, they are still at risk from thrown objects. Encourage bystanders to wear eye protection. If you are approached, stop the unit immediately.
- Squeeze the throttle control and check that it returns automatically to the idle position. Make all adjustments or repairs before using the unit.
- This unit is intended for occasional, household use only.

SAFETY WARNINGS FOR GAS UNITS



WARNING: Gasoline is highly flammable and its vapors can explode if ignited. Take the following precautions:

- Store fuel only in containers specifically designed and approved for the storage of such materials.
- Always stop the engine and allow it to cool before filling the tank. Never remove the fuel tank cap or add fuel when the engine is hot. Always loosen the fuel tank cap slowly to relieve any pressure in the tank before fueling.
- Always add fuel in a clean, well-ventilated outdoor area where there are no sparks or flames. DO NOT smoke.
- Never operate the unit without the fuel cap securely in place.
- Avoid creating a source of ignition for spilled fuel. Wipe up any spilled fuel from the unit immediately, before starting the unit. Move the unit at least 30 ft. (9.1 m) from the fueling source and site before starting the engine. DO NOT smoke.
- Never start or run the unit inside a closed room or building. Breathing exhaust fumes can kill. Operate this unit only in a well ventilated outdoor area.

WHILE OPERATING

- Wear safety glasses or goggles that meet current ANSI / ISEA Z87.1 standards and are marked as such. Wear ear/hearing protection when operating this unit. Wear a face mask or dust mask if the operation is dusty.
- Wear heavy long pants, boots, gloves and a long sleeve shirt. Do not wear loose clothing, jewelry, short pants, sandals or go barefoot. Secure hair above shoulder level.
- The cutting head shield must always be in place while operating the unit. Do not operate the unit without both trimming lines extended and the proper line installed. Do not extend the trimming line beyond the length of the shield.
- This unit has a clutch. The cutting head remains stationary when the engine is idling. If it does not, take the unit to a Sears or other qualified service dealer for an adjustment.
- Adjust the handle to provide the best grip, if applicable.
- Make sure the attachment is not in contact with anything before starting the unit.
- Use the unit only in daylight or good artificial light.
- Avoid accidental starting. Be in the starting position whenever pulling the starter rope. The operator and unit must be in a stable position while starting. Refer to *Starting and Stopping*.
- Use the right tool. Only use this tool for its intended purpose.
- Always hold the unit with both hands when operating. Keep a firm grip on both handles or grips.
- Do not overreach. Always keep proper footing and balance. Take extra care when working on stairs, steep slopes or inclines. To avoid serious injury, do not operate the unit while on a ladder or a roof.
- Keep hands, face, and feet away from all moving parts. Do not touch or try to stop moving parts.
- Do not touch the engine, gear housing or muffler. These parts get extremely hot from operation, even after the unit is turned off.
- Do not operate the unit faster than the speed needed to do the job. Do not run the unit at high speed when not in use.
- Do not force the unit. It will do a better, safer job when used at the intended rate.
- Always stop the unit when operation is delayed or when walking from one location to another.
- If you strike or become entangled with a foreign object, stop the unit immediately and check for damage. Do not operate the unit before repairing damage. Do not operate the unit with loose or damaged parts.
- Turn the engine to off and disconnect the spark plug for maintenance or repair.
- Use only original equipment manufacturer (OEM) replacement parts and accessories for this unit. Use of any other parts or accessories could lead to serious injury to the user, or damage to the unit, and void the warranty.
- Keep the unit clean. Carefully remove vegetation and other debris that could block moving parts.
- To reduce fire hazard, replace a faulty muffler and spark arrestor. Keep the engine and muffler free from grass, leaves, excessive grease or carbon build up.
- If the unit starts to vibrate abnormally, stop the unit immediately. Inspect the unit for the cause of the vibration. Vibration is generally an indicator of trouble.

OTHER SAFETY WARNINGS

- All service, other than the maintenance procedures described in this manual, should be performed by a Sears or other qualified service dealer.
- Before inspecting, servicing, cleaning, storing, transporting or replacing any parts on the unit:
 1. Stop the unit.
 2. Make sure all moving parts have stopped.
 3. Allow the unit to cool.
 4. Disconnect the spark plug wire.
- Secure the unit while transporting.
- Never store the unit with fuel in the tank, inside a building where fumes may reach an open flame (pilot lights, etc.) or sparks (switches, electrical motors, etc.).







- Store the unit in a dry place, secured or at a height to prevent unauthorized use or damage. Keep the unit out of the reach of children.
- Never douse or squirt the unit with water or any other liquid. Keep handles dry and clean (free from debris, oil and grease). Clean the unit after each use. Refer to *Cleaning and Storage*. Do not use solvents or strong detergents.
- Keep these instructions. Refer to them often and use them to instruct other users. If you loan this unit to others, also loan them these instructions.

SAVE THESE INSTRUCTIONS









• SAFETY & INTERNATIONAL SYMBOLS •

This operator's manual describes safety and international symbols and pictographs that may appear on this product. Read the operator's manual for complete safety, assembly, operating and maintenance and repair information.

SYMBOL MEANING

	<ul style="list-style-type: none"> • SAFETY ALERT SYMBOL Indicates danger, warning or caution. May be used in conjunction with other symbols or pictographs.
	<ul style="list-style-type: none"> • READ OPERATOR'S MANUAL WARNING: Read the operator's manual(s) and follow all warnings and safety instructions. Failure to do so can result in serious injury to the operator and/or bystanders.
	<ul style="list-style-type: none"> • WEAR EYE AND HEARING PROTECTION WARNING: Thrown objects and loud noise can cause severe eye injury and hearing loss. Wear eye protection meeting current ANSI / ISEA Z87.1 standards and ear protection when operating this unit. Use a full face shield when needed.
	<ul style="list-style-type: none"> • UNLEADED FUEL Always use clean, fresh unleaded fuel.
	<ul style="list-style-type: none"> • OIL Refer to operator's manual for the proper type of oil.
	<ul style="list-style-type: none"> • DO NOT USE E85 FUEL IN THIS UNIT WARNING: It has been proven that fuel containing greater than 10% ethanol will likely damage this engine and void the warranty.

SYMBOL MEANING

	<ul style="list-style-type: none"> • ON/OFF STOP CONTROL ON / START / RUN
	<ul style="list-style-type: none"> • ON/OFF STOP CONTROL OFF or STOP
	<ul style="list-style-type: none"> • PRIMER BULB Push primer bulb, fully and slowly, 10 times.
	<ul style="list-style-type: none"> • CHOKE CONTROL <ol style="list-style-type: none"> 1. • FULL choke position 2. • PARTIAL choke position 3. • RUN choke position
	<ul style="list-style-type: none"> • THROWN OBJECTS AND ROTATING CUTTER CAN CAUSE SEVERE INJURY WARNING: Small objects can be propelled at high speed, causing injury. Keep away from the rotating rotor.
	<ul style="list-style-type: none"> • KEEP BYSTANDERS AWAY WARNING: Keep all bystanders, especially children and pets, at least 50 feet (15 m) from the operating area.
	<ul style="list-style-type: none"> • HOT SURFACE WARNING: Do not touch a hot muffler or cylinder. You may get burned. These parts get extremely hot from operation. When turned off they remain hot for a short time.
	<ul style="list-style-type: none"> • SHARP BLADE WARNING: Sharp blade on trimmer attachment shield. To prevent serious injury, do not touch the line cutting blade.

WARRANTY

CRAFTSMAN TWO YEAR FULL WARRANTY

FOR TWO YEARS from the date of purchase, this product is warranted against any defects in material or workmanship. A defective product will receive free repair or replacement if repair is unavailable.

ADDITIONAL LIMITED WARRANTY on TRIMMER SHAFTS

FOR THE THIRD THROUGH TENTH YEAR from the date of purchase, the outer metal housing of the upper and lower trimmer shafts is warranted against any defects in material or workmanship. With proof of purchase, a new housing will be supplied free of charge. You are responsible for the labor cost of installation. This additional coverage does not apply to inner trimmer shaft components.

For warranty coverage details to obtain free repair or replacement, visit the web page: www.craftsman.com/warranty

This warranty covers ONLY defects in material and workmanship. Warranty coverage does NOT include:

- Expendable items that can wear out from normal use within the warranty period, such as cutting line, spark plugs, or filters.
- Product damage resulting from user attempts at product modification or repair or caused by product accessories.
- Repairs necessary because of accident or failure to operate or maintain the product according to all supplied instructions.
- Preventive maintenance, or repairs necessary due to improper fuel mixture, contaminated or stale fuel.

This warranty is void if this product is ever used while providing commercial services or if rented to another person.

This warranty gives you specific legal rights, and you may also have other rights which vary from state to state.

Sears Brands Management Corporation, Hoffman Estates, IL 60179

To order parts or schedule service for this product, call 1-800-469-4663.

KNOW YOUR UNIT

APPLICATIONS

As a trimmer:

- Cutting grass and light weeds.
- Edging
- Decorative trimming around trees, fences, etc.

Other optional accessories may be used with this unit.

ASSEMBLY TOOLS REQUIRED:

- #2 Phillips screwdriver
- 3/8" Socket

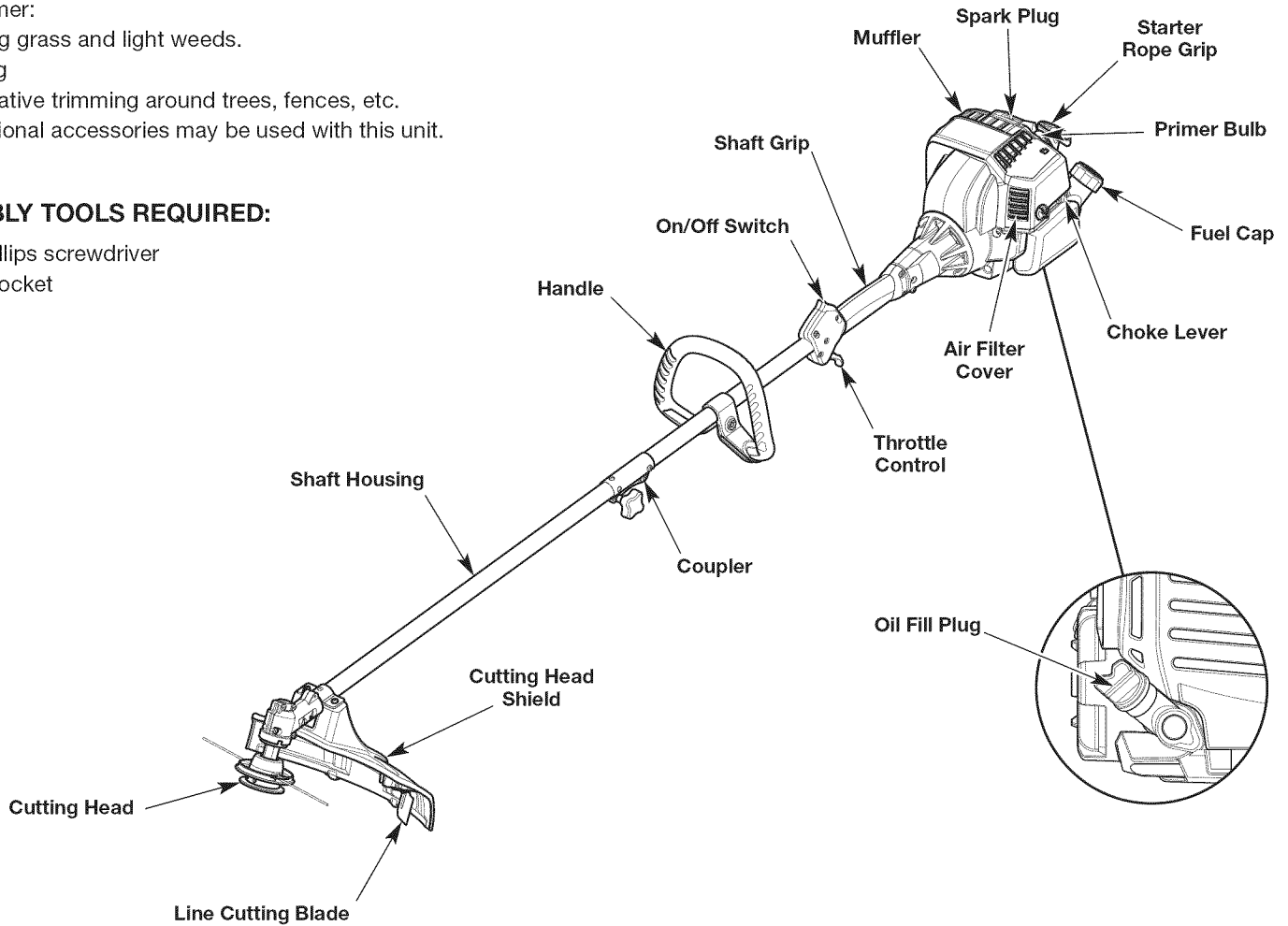

SPECIFICATIONS*

Engine Type	Air-Cooled, 4-Cycle
Displacement	30 cc (1.83 cu. in.)
Spark Plug Gap	0.025 in. (0.635 mm)
Spark Plug	Champion® RDZ4H or equivalent plug
Lubrication	SAE 30 Oil
Crankcase Oil Capacity	2.03 oz. (60 ml)
Fuel Tank Capacity	12 oz. (355 ml)
Approximate Unit Weight (No fuel, with cutting head, cutting head shield and handle).	13 - 14 lbs. (5.9 - 6.4 kg)
Trimmer Mechanism	Hassle Free™ Head
Trimming Line	Hassle Free™ XTRA QUIET Spiral Line
Cutting Path Diameter	14 in. (35.56 cm)

* All specifications are based on the latest product information available at the time of printing. We reserve the right to make changes at any time without notice.



INSTALLING THE CUTTING HEAD SHIELD



WARNING: To prevent serious personal injury, never operate the unit without the cutting head shield in place.

1. Place the cutting head shield onto the mount bracket. Align the holes in the cutting head shield with the holes in the mount bracket. (Fig. 1)
2. Screw the 2 screws through the mount bracket and into the cutting head shield until finger tight.
3. Using a #2 Phillips screwdriver, tighten the screws until the cutting head shield is firmly in place. Tighten the screws equally. The gap between the mount bracket and the cutting head shield should be the same on each side.

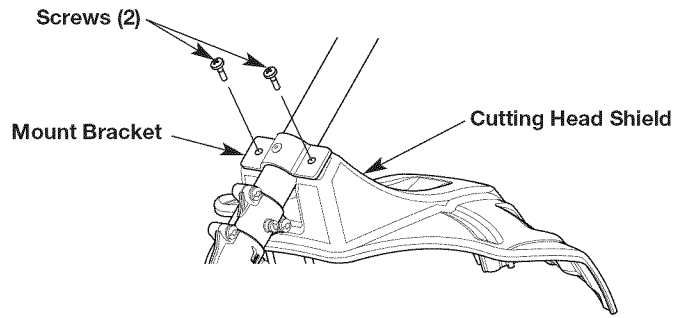

Fig. 1

INSTALLING AND ADJUSTING THE HANDLE

Installing the Handle

1. Push the handle down onto the shaft housing (Fig. 2). The bolt hole in the handle should be to the right.
2. Insert the bolt into the bolt hole and push it through (Fig. 2). Tighten the bolt with a 3/8" socket, but do not tighten the bolt completely.
3. While holding the unit in the operating position (Fig. 13), move the handle to the location that provides the best grip. Place it a minimum of 6 inches (15.24 cm) from the end of the shaft grip (Fig. 2).
4. Tighten the bolt with a 3/8" socket until the handle is secure.

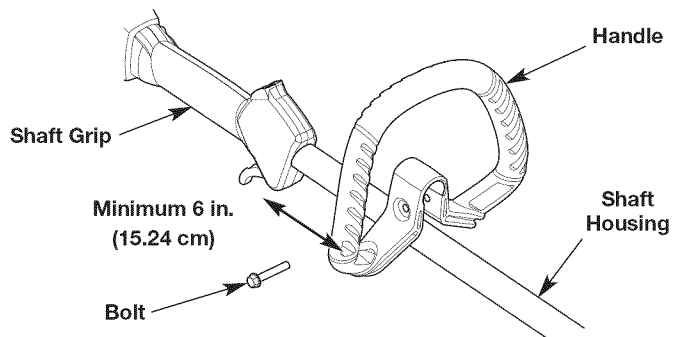

Fig. 2

Adjusting the Handle

If the handle requires adjustment:

1. Loosen the bolt with a 3/8" socket (Fig. 2).
2. While holding the unit in the operating position (Fig. 13), move the handle to the location that provides the best grip. Place it a minimum of 6 inches (15.24 cm) from the end of the shaft grip (Fig. 2).
3. Tighten the bolt with a 3/8" socket until the handle is secure.



WARNING: Before using any attachment, read and understand the manual that came with the attachment. Follow all safety information contained within.



WARNING: To avoid serious personal injury and damage to the unit, shut the unit off before removing or installing an attachment.

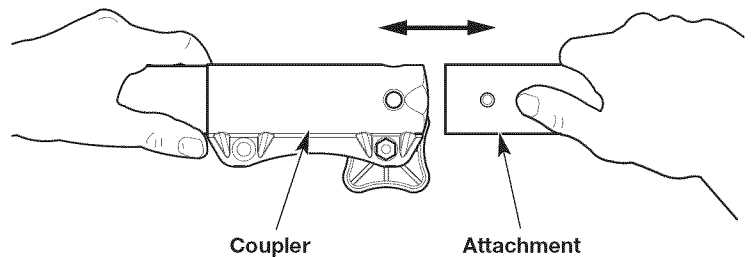

Fig. 3

OPERATING THE COUPLER

The coupler enables the use of various optional attachments.

Installing the Attachment

1. Remove the hanger cap from the attachment. Keep the hanger cap for use when storing the attachment. If present, remove the gray spacer from the coupler.
2. Set the unit on a flat, level surface.
3. Turn the knob counterclockwise to loosen the coupler (Fig. 4).

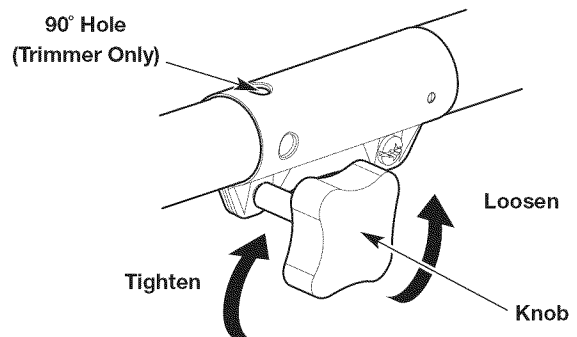

Fig. 4

- Align the release button with the guide recess (Fig. 5).
- Push the attachment straight into the coupler (Fig. 3) until the release button snaps firmly into the primary hole (Fig. 5).
- Turn the knob clockwise to tighten the coupler (Fig. 4).

NOTE: Do not tighten the nut (Fig. 5).

NOTE: For decorative trimming with a string trimmer attachment, lock the release button into the 90° hole (Fig. 4).

CAUTION: Before operating the unit, make sure the release button is fully snapped into the primary hole and the knob is securely tightened.

CAUTION: Unless specified otherwise, the release button should be snapped into the primary hole only. Using the wrong hole could lead to personal injury or damage to the unit.

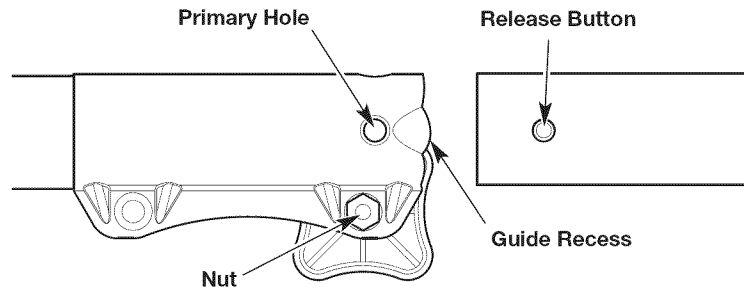

Fig. 5

Removing the Attachment

- Set the unit on a flat, level surface.
- Turn the knob counterclockwise to loosen the coupler (Fig. 4).
- Press and hold the release button (Fig. 5).
- Pull the attachment straight out of the coupler (Fig. 3).

OIL AND FUEL

USING THE RIGHT OIL

Use a high-quality SAE 30 weight oil. **DO NOT** use dirty oil. Failure to use clean oil of the correct type can cause premature engine wear and failure.

ADDING OIL: INITIAL USE

WARNING: OVERFILLING THE CRANKCASE MAY CAUSE SERIOUS PERSONAL INJURY. Check the oil level before each use. The importance of maintaining the proper oil level cannot be overemphasized. Change the oil according to the *Maintenance Schedule*.

NOTE: This unit was shipped without oil in the crankcase. Oil must be added before starting the unit.

NOTE: This unit comes with a 2.03 fluid oz. (60 ml) bottle of oil.

- Unscrew the top of the oil bottle. Remove the paper seal. Reinstall the top of the oil bottle.
- Remove the cap from the oil bottle. Cut the tip off the funnel spout (Fig. 6).
- Set the unit on a flat, level surface.**
- Unscrew the oil fill plug (Fig. 7).
- Pour the entire bottle into the oil fill hole (Fig. 7). **DO NOT** overfill. Refer to *Checking the Oil Level*.

NOTE: Never add oil directly to the fuel tank. This unit has a four-cycle engine. **DO NOT** mix oil with gasoline.

- Wipe up any oil that may have spilled.
- Reinstall the oil fill plug.

NOTE: Make sure the O-ring is in place on the oil fill plug (Fig. 7).

NOTE: Save the empty oil bottle. Use the bottle to measure the correct amount of oil during future oil changes.

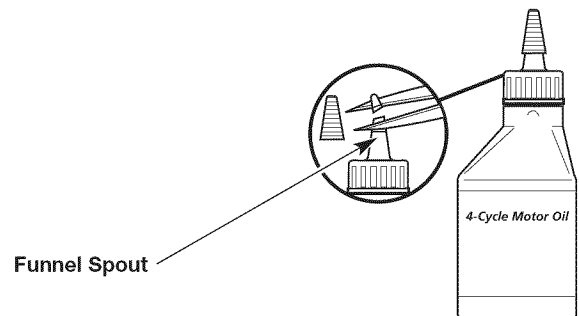

Fig. 6

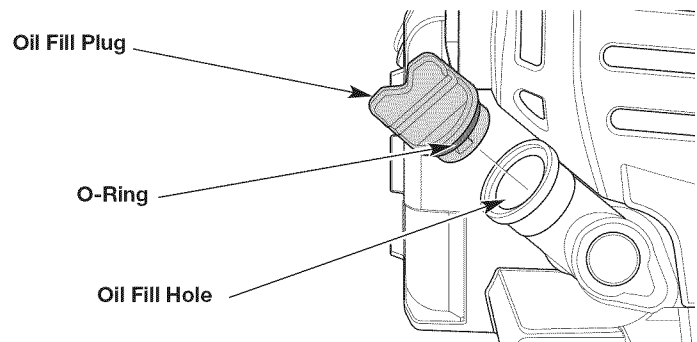

Fig. 7

USING THE RIGHT FUEL

The use of old fuel is the most common cause of performance problems. Use only fresh, clean unleaded gasoline.

NOTE: This unit has a four-cycle engine. **DO NOT** mix oil with gasoline.

Definition of Blended Fuels

Today's fuels are often a blend of gasoline and oxygenates such as ethanol, methanol or MTBE (ether). Alcohol-blended fuel absorbs water. As little as 1% water in the fuel can make fuel and oil separate, forming acids when stored. **ALWAYS** use fresh fuel (less than 30 days old).

NOTE: Dispose of old fuel according to federal, state and local regulations.

Using Blended Fuels

If using a blended fuel:

- Always use fresh unleaded gasoline
- Use the fuel additive STA-BIL® or an equivalent
- Drain the tank and run the engine dry before storing the unit



WARNING: DO NOT USE E85 FUEL IN THIS UNIT.

It has been proven that fuel containing greater than 10% ethanol will likely damage this engine and void the warranty.

Using Fuel Additives

Use a fuel additive, such as STA-BIL Fuel Stabilizer or an equivalent, to inhibit corrosion and minimize gum deposits. Add 0.8 oz. (23 ml) of fuel additive per gallon of fuel, according to the instructions on the container. **NEVER** add fuel additives directly to the unit's fuel tank.

FUELING THE UNIT



WARNING: Gasoline is extremely flammable. Ignited vapors may explode. Always stop the engine and allow it to cool before filling the fuel tank. Do not smoke while filling the tank. Keep sparks and open flames at a distance from the area.



WARNING: Remove the fuel cap slowly to avoid injury from fuel spray. Never operate the unit without the fuel cap securely in place.



WARNING: Add fuel in a clean, well ventilated outdoor area. Wipe up any spilled fuel immediately. Avoid creating a source of ignition for spilled fuel. Do not start the engine until fuel vapors dissipate.

1. Position the unit with the fuel cap facing up.
2. Remove the fuel cap.
3. Place the fuel container spout into the fill hole on the fuel tank and fill the tank.

NOTE: Do not overfill the tank.

4. Wipe up any fuel that may have spilled.
5. Reinstall the fuel cap.
6. Move the unit at least 30 ft. (9.1 m) from the fuel container and the fueling site before starting the engine.

STARTING AND STOPPING



WARNING: Operate this unit only in a well-ventilated outdoor area. Carbon monoxide exhaust fumes can be lethal in a confined area.



WARNING: Avoid accidentally starting the unit. To avoid serious injury, the operator and the unit must be in a stable position when pulling the starter rope (Fig. 11).

STARTING INSTRUCTIONS

1. Check the oil level. Refer to *Checking the Oil Level*.
2. Fill the fuel tank. Refer to *Fueling the Unit*.

NOTE: There is no need to turn the unit on. The On/Off switch is in the ON (I) position at all times (Fig. 8).

3. Slowly press and release the primer bulb **10 times** (Fig. 9).
4. Move the choke lever to **Position 1** (Fig. 10).
5. Crouch in the starting position (Fig. 11).

NOTE: SQUEEZE and HOLD the throttle control for **ALL** further steps.

6. Squeeze the throttle control (Fig. 8) and pull the starter rope with a controlled and steady motion **5 times** (Fig. 11).

NOTE: This unit uses the **INCREDI-PULL™** starting system, which significantly reduces the effort required to start the engine.

7. Continue to squeeze the throttle control. Move the choke lever to **Position 2** (Fig. 10).
8. Continue to squeeze the throttle control. Pull the starter rope with a controlled and steady motion **3 to 5 times** to start the engine.
9. Continue to squeeze the throttle control. Allow the engine to warm up for 30 to 60 seconds.
10. Continue to squeeze the throttle control. Move the choke lever to **Position 3** (Fig. 10) and continue warming the engine for an additional 60 seconds. The unit may be used during this time.

IF... the engine does not start, begin the starting procedure with step 3.

IF... the engine fails to start after a few attempts, move the choke lever to **Position 3** and squeeze the throttle control. Pull the starter rope with a controlled and steady motion **3 to 8 times**. The engine should start. If it does not, repeat this instruction.

IF THE UNIT WAS RUN FOR 10-15 MINUTES AND THE ENGINE IS HOT... perform steps 3 - 8 to restart the engine. Continue to squeeze the throttle control. Run the unit for **2-5 minutes**, or as needed. **The unit may be used during this time.** Then move the choke lever to **Position 3**.

If the engine speed fluctuates in **Position 3**, squeeze and hold the throttle control, move the choke lever to **Position 2**, and run the unit for **2-5 minutes**, or as needed. **The unit may be used during this time.** Then move the choke lever to **Position 3**.

STOPPING INSTRUCTIONS

1. Release the throttle control and allow the engine to idle.
2. Press and hold the On/Off switch in the OFF (O) position until the engine comes to a complete stop (Fig. 8).

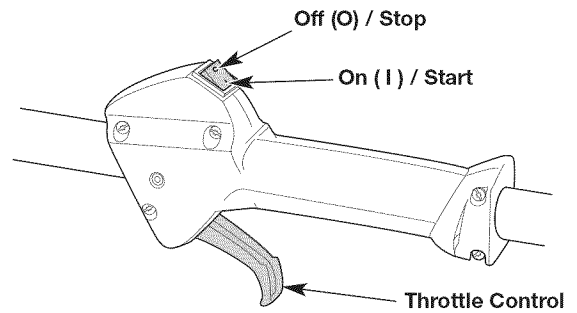

Fig. 8

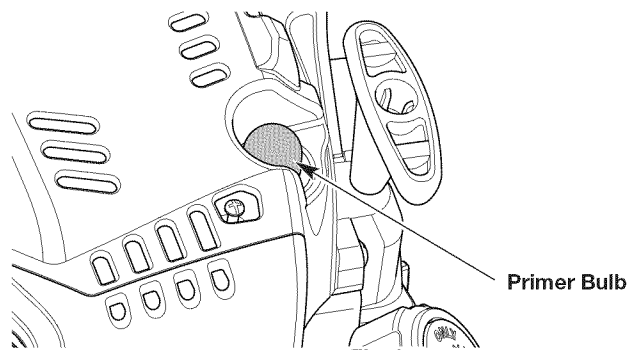

Fig. 9

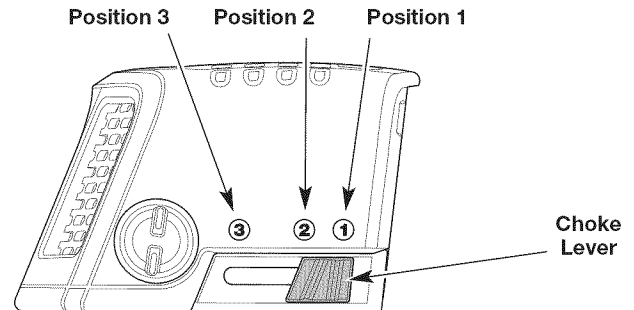

Fig. 10

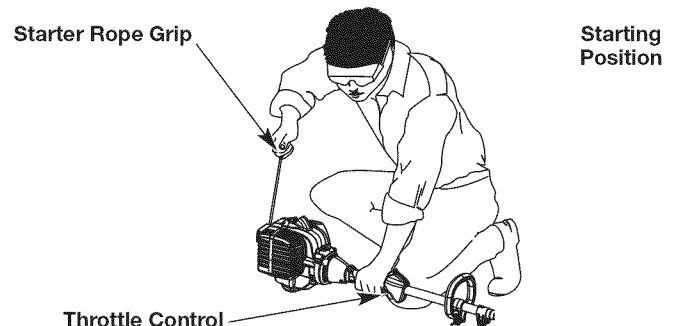

Fig. 11

USING THE SPEED START™ ACCESSORY

This unit can be started with an optional Speed Start™ accessory (items sold separately). Please refer to the Speed Start™ accessory operator's manual for the proper use of this feature.

Please contact your local Craftsman retailer, call **1-800-469-4663** or visit **www.craftsman.com** for more information.

Item No.	Description
316.85951	Plug-In Power Start
316.85952	Power Bit Start
316.85953	Cordless Power Start

STARTING INSTRUCTIONS

1. Check the oil level. Refer to *Checking the Oil Level*.
2. Fill the fuel tank. Refer to *Fueling the Unit*.

NOTE: There is no need to turn the unit on. The On/Off switch is in the ON (I) position at all times (Fig. 8).

3. Slowly press and release the primer bulb **10 times** (Fig. 9).
4. Move the choke lever to **Position 1** (Fig. 10).
5. Crouch in the starting position (Fig. 11).
6. Insert the Speed Start™ accessory into the Speed Start™ port (Fig. 12). Refer to the *Operation* section of the Speed Start™ accessory operator's manual.

NOTE: SQUEEZE and HOLD the throttle control for **ALL** further steps.

7. Squeeze and hold the throttle control (Fig. 8). Run the Speed Start™ accessory for 2 seconds.
8. Continue to squeeze the throttle control. Move the choke lever to **Position 2** (Fig. 10).
9. Continue to squeeze the throttle control. Run the Speed Start™ accessory in intervals no longer than 2 seconds each until the unit starts.
10. Remove the Speed Start™ accessory from the unit.
11. Continue to squeeze the throttle control. Allow the engine to warm up for 30 to 60 seconds.
12. Continue to squeeze the throttle control. Move the choke lever to **Position 3** (Fig. 10) and continue warming the engine for an additional 60 seconds. The unit may be used during this time.

IF... the engine does not start, begin the starting procedure with step 3.

IF... the engine fails to start after a few attempts, move the choke lever to **Position 3** and squeeze the throttle control. Run the Speed Start™ accessory in intervals no longer than 2 seconds each until the unit starts. The engine should start. If it does not, repeat this instruction.

IF THE UNIT WAS RUN FOR 10-15 MINUTES AND THE ENGINE IS HOT... perform steps 3 - 10 to restart the engine. Continue to squeeze the throttle control. Run the unit for **2-5 minutes**, or as needed. **The unit may be used during this time.** Then move the choke lever to **Position 3**.

If the engine speed fluctuates in **Position 3**, squeeze and hold the throttle control, move the choke lever to **Position 2**, and run the unit for **2-5 minutes**, or as needed. **The unit may be used during this time.** Then move the choke lever to **Position 3**.

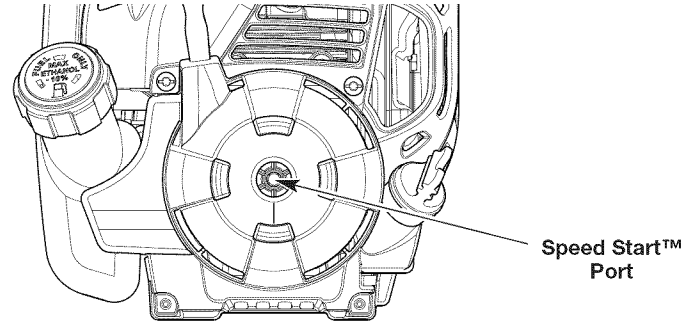

Fig. 12

STOPPING INSTRUCTIONS

1. Release the throttle control and allow the engine to idle.
2. Press and hold the On/Off switch in the OFF (O) position until the engine comes to a complete stop (Fig. 8).

HOLDING THE UNIT



WARNING: Always wear eye, hearing, hand, foot and body protection to reduce the risk of injury when operating this unit.

- Stand in the operating position (Fig. 13). Stand up straight. Do not bend over.
- Keep feet apart and firmly planted.
- Hold the shaft grip with the right hand. Keep the right arm slightly bent.
- Hold the handle with the left hand. Keep the left arm straight.
- Hold the unit at waist level.
- Position the cutting head a few inches above the ground.



Fig. 13

TIPS FOR BEST RESULTS

- To direct clippings away from the operator, tilt the cutting head slightly down to the right; cut from left to right whenever possible.
- Do not trim wet grass or weeds.

NOTE: Some line breakage will occur from:

- Entanglement with foreign matter
- Normal line fatigue
- Attempting to cut thick vegetation
- Forcing the line into objects such as walls or fence posts

DECORATIVE TRIMMING

When trimming around trees, posts, fences, etc., rotate the whole unit so that the cutting head is at a 30° angle to the ground (Fig. 14).

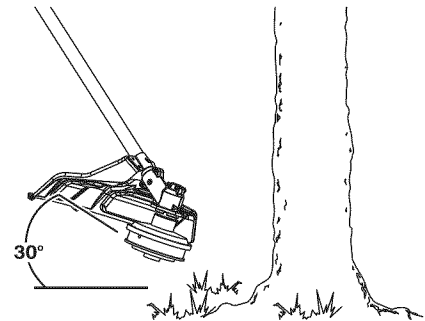

Fig. 14



WARNING: To prevent serious injury, never perform maintenance or repairs while the unit is running. Always allow the unit to cool before servicing or repairing the unit. Disconnect the spark plug wire to prevent the unit from starting accidentally.

MAINTENANCE SCHEDULE

Perform these required maintenance procedures at the frequency stated in the table. These procedures should also be a part of any seasonal tune-up.

NOTE: Some maintenance procedures may require special tools or skills. If unsure about these procedures, take the unit to a Sears or other qualified service dealer. Call **1-800-469-4663** for more information.

NOTE: Maintenance, replacement, or repair of the emission control devices and system may be performed by a Sears or other qualified service dealer. Call **1-800-469-4663** for more information.

NOTE: Please read the California/EPA statement that came with the unit for a complete listing of terms and coverage for the emissions control devices, such as the spark arrestor, muffler, carburetor, etc.

FREQUENCY	MAINTENANCE REQUIRED
Every 10 hours	<ul style="list-style-type: none"> Clean and re-oil the air filter. Refer to <i>Maintaining the Air Filter</i>.
After the first 10 hours and at 38 hours	<ul style="list-style-type: none"> Change the oil. Refer to <i>Changing the Oil</i>. Have the rocker arm clearance checked by a Sears or other qualified service dealer. Check the spark plug condition and gap. Refer to <i>Maintaining the Spark Plug</i>.

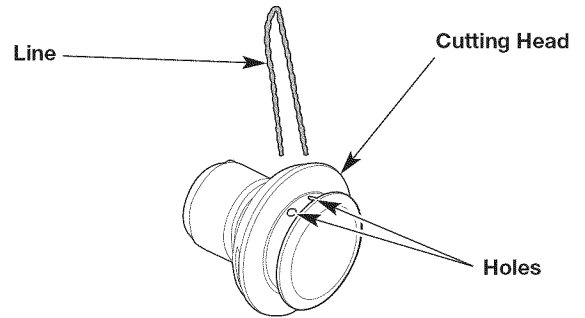

Fig. 15

REPLACING THE TRIMMING LINE

Only use the trimming line described in the *Specifications* section. Other types of trimming line may cause the unit to overheat or fail.



WARNING: Never use metal-reinforced line, wire, chain or rope. These can break off and become dangerous projectiles.

NOTE: When using Craftsman® Hassle Free™ XTRA QUIET Spiral Line, use the line best suited for the job at hand. Medium-sized (red) line is designed for cutting grass and small weeds. Large-sized (black) line is designed for cutting larger weeds and light brush.

Installing New Trimming Line

1. Remove the old line from the cutting head.
2. Use a clean cloth to clean the surface of the cutting head.
3. Insert the ends of the line through the large circular holes in the side of the cutting head (Fig. 15). Push the line through the holes until both ends protrude from the positioning tunnels (Fig. 16).
4. Pull the ends of the line until the line is tight against the cutting head. Make sure the ends of the line are of equal length (Fig. 17).

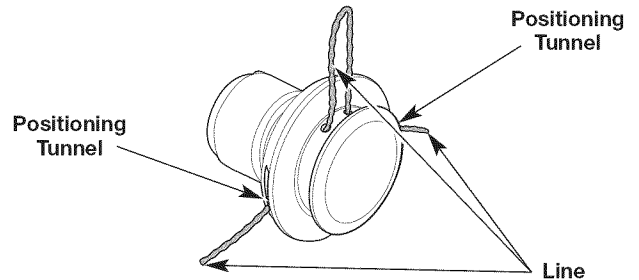

Fig. 16

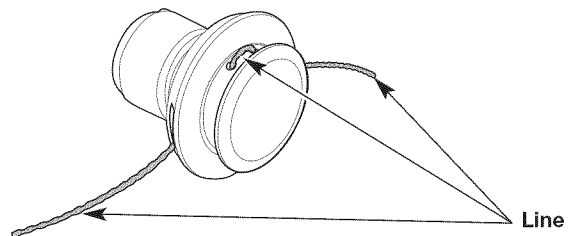
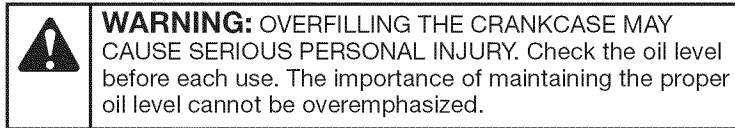

Fig. 17

CHECKING THE OIL LEVEL



Inspecting the Oil Level Window

1. Stop the engine and allow it to cool.
2. **Set the unit on a flat, level surface**, such as a workbench or table. The cutting head shield should hang over the edge so that the engine is level (Fig. 18).

NOTE: Failure to keep the engine level may cause the oil to overflow.

3. Look into the oil level window; use a flashlight if necessary. **The oil level should fill the window approximately halfway** (Fig. 19). If the oil level is too low, add oil. Refer to *Adding Oil*.

Adding Oil

1. Clean the area around the oil fill plug (Fig. 19) to prevent debris from entering the oil fill hole.
2. Unscrew the oil fill plug.
3. Add oil to the oil fill hole until the oil level is approximately halfway up the oil level window (Fig. 19).

NOTE: DO NOT overfill the crankcase.

4. Wipe up any oil that may have spilled.
5. Reinstall the oil fill plug.

NOTE: Make sure the O-ring is in place on the oil fill plug (Fig. 19).

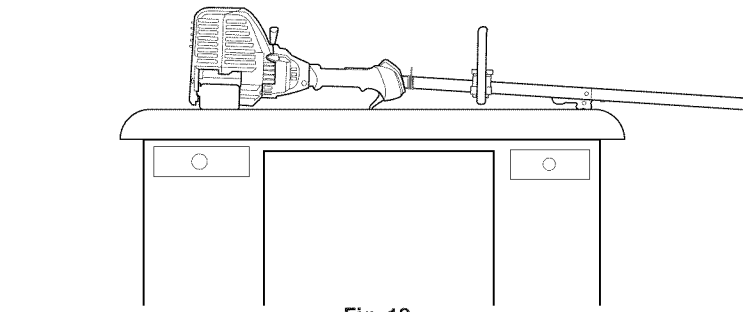

Fig. 18

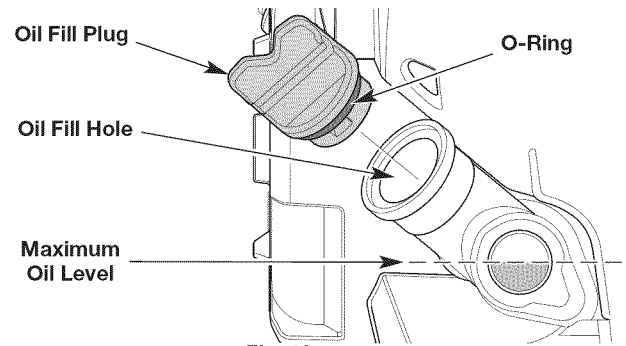

Fig. 19

CHANGING THE OIL

Change the oil while the engine is still warm. The oil will flow freely and carry away more impurities.

1. Clean the area around the oil fill plug (Fig. 19) to prevent debris from entering the oil fill hole.
2. Unscrew the oil fill plug.
3. Tip the unit vertically to pour the oil out of the oil fill hole and into a container (Fig. 20). Allow ample time for complete drainage.

NOTE: Dispose of the old oil according to federal, state and local regulations.

4. Wipe up any oil that may have spilled.
5. Pour 2.03 fl.oz. (60 ml) of SAE 30 oil into the oil fill hole.

NOTE: DO NOT overfill. Refer to *Checking the Oil Level*.

NOTE: Use the empty oil bottle saved from the initial use to measure the correct amount of oil. Fill the oil bottle to the 2.03 fl. oz (60 ml) fill line indicated on the back of the bottle (Fig. 21).

6. Wipe up any oil that may have spilled.
7. Reinstall the oil fill plug.

NOTE: Make sure the O-ring is in place on the oil fill plug (Fig. 19).

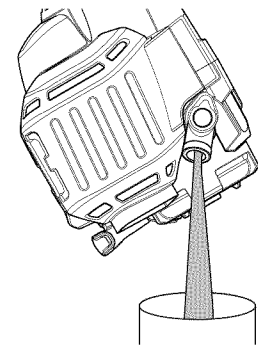

Fig. 20

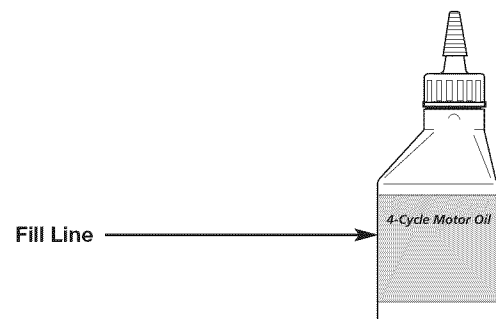

Fig. 21

MAINTAINING THE AIR FILTER



WARNING: To avoid serious personal injury, always stop the engine and allow it to cool before cleaning or maintaining the unit.

Failure to maintain the air filter can result in poor performance or can cause permanent damage to the engine. Engine failure due to improper air filter maintenance is not covered by the product warranty.

Cleaning the Air Filter

1. Unscrew the cover screw completely. Swing the air filter cover to the right. Remove the air filter cover from the air filter housing (Fig. 22).
2. Remove the air filter from the air filter housing (Fig. 22).
3. Wash the air filter in detergent and water. Rinse the air filter thoroughly and allow it to dry.
4. Lightly coat the air filter with clean SAE 30 oil.
5. Squeeze the air filter to spread and remove excess oil.
6. Reinstall the air filter in the air filter housing (Fig. 22).

NOTE: Operating the unit without the air filter and air filter cover will VOID the warranty.

7. Insert the tab on the air filter cover into the hole on the air filter housing. Swing the air filter cover to the left. Push the air filter cover back onto the air filter housing. Insert the cover screw into the air filter cover. Tighten the cover screw to secure the air filter cover (Fig. 22).

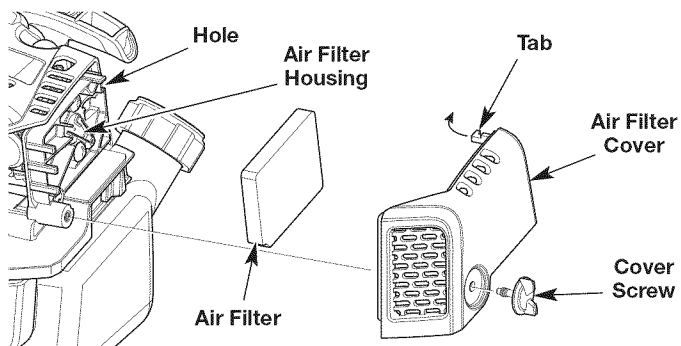

Fig. 22

ADJUSTING THE IDLE SPEED



WARNING: The cutting head may spin during idle speed adjustments. Wear protective clothing and observe all safety instructions to prevent serious personal injury.

NOTE: Careless adjustments can seriously damage the unit. A Sears or other qualified service dealer should make carburetor adjustments.

If, after checking the fuel and cleaning the air filter, the engine still will not idle, adjust the idle speed screw as follows:

1. Start the engine. Refer to *Starting and Stopping*.
2. Release the throttle control and let the engine idle.
 - If the engine stops, use a small Phillips screwdriver to turn the idle speed screw clockwise, 1/8 of a turn at a time (as needed) until the engine idles smoothly (Fig. 23).
 - If the engine idles too quickly, turn the idle speed screw counterclockwise, 1/8 of a turn at a time (as needed) to reduce the idle speed (Fig. 23).

NOTE: The cutting head should not spin when the engine idles. If it does, reduce the idle speed until the cutting head stops moving.

Checking the fuel, cleaning the air filter, and adjusting the idle speed should solve most engine problems. If not, and any of the following conditions are true, take the unit to a Sears or other qualified service dealer:

- the engine will not idle
- the engine hesitates or stalls on acceleration
- there is a loss of engine power

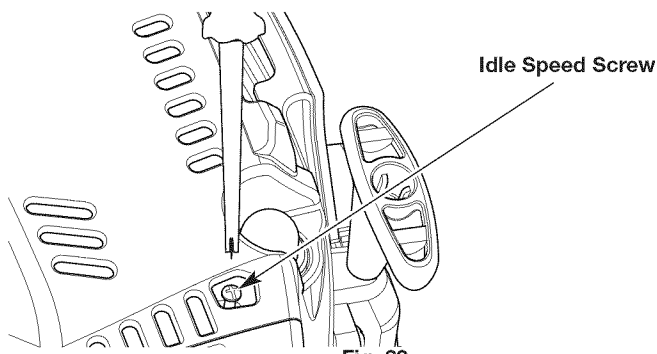
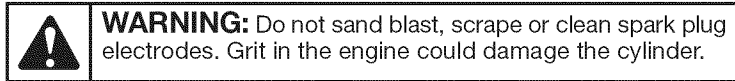

Fig. 23

MAINTAINING THE SPARK PLUG

1. Stop the engine and allow it to cool. Grasp the spark plug boot firmly and pull it from the spark plug.
2. Clean around the spark plug. Remove the spark plug from the cylinder head with a 5/8-inch socket, turning counterclockwise.



3. Inspect the spark plug. If the spark plug is cracked, fouled or dirty, replace it with replacement part #753-05784, a **Champion RDZ4H** or an equivalent spark plug.
4. Use a feeler gauge to set the air gap at **0.025 in. (0.635 mm)** (Fig. 24).
5. Install the spark plug in the cylinder head. Tighten the spark plug with a 5/8-inch socket, turning it clockwise until snug.

NOTE: If using a torque wrench, torque to:

110-120 in.•lb. (12.3-13.5 N•m). Do not over tighten.

6. Reattach the spark plug boot.

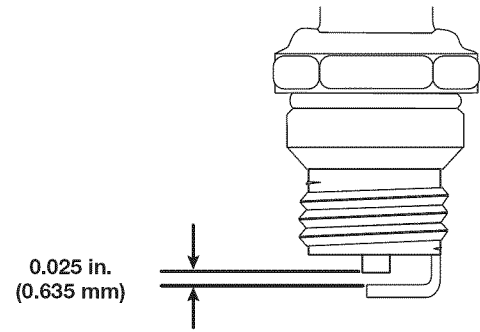
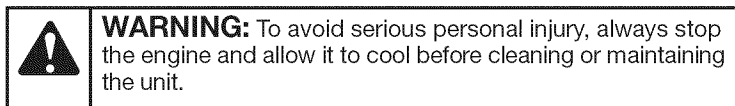

Fig. 24

CLEANING AND STORAGE

CLEANING



Use a small brush to clean the outside of the unit. Do not use strong detergents. Household cleaners that contain aromatic oils such as pine and lemon, and solvents such as kerosene, can damage plastic. Wipe off any moisture with a soft cloth.

STORAGE

- Never store a fueled unit where fumes may reach an open flame or spark.
- Allow the engine to cool before storing.
- Lock up the unit to prevent unauthorized use or damage.
- Store the unit in a dry, well-ventilated area.
- Store the unit out of the reach of children.
- To suspend the attachment from a hook, install the hanger cap onto the attachment. Make sure the release button is securely locked into one of the holes on the hanger cap.

Short-term Storage (1-2 weeks)

1. Store the unit in a horizontal position. If this is not possible, store the unit vertically with the engine at the top.

Long-term Storage

1. Remove the fuel cap, tip the unit and drain the fuel into an approved container. Reinstall the fuel cap.
2. Start the engine and allow it to run until it stalls. This ensures that all fuel has been drained from the carburetor.
3. Allow the engine to cool. Remove the spark plug and put 5 drops of any high quality motor oil into the cylinder. Pull the starter rope slowly to distribute the oil. Reinstall the spark plug.
4. Thoroughly clean the unit and inspect it for any loose or damaged parts. Repair or replace damaged parts and tighten loose screws, nuts or bolts.

Preparing the Unit for Use after Long-term Storage

1. Remove the spark plug and drain all of the oil from the cylinder.
2. Change the oil. Refer to *Changing the Oil*.

NOTE: Do not use fuel that has been stored for more than 30 days. Dispose of old fuel according to federal, state and local regulations.

TROUBLESHOOTING

PROBLEM	SOLUTION
THE ENGINE WILL NOT START	
The fuel tank is empty	Fill the fuel tank with fresh fuel
The primer bulb was not pressed enough	Press the primer bulb 10 times
The fuel is old (over 30 days)	Drain the fuel tank and add fresh fuel
The spark plug is fouled	Replace the spark plug
The engine is hot	Refer to the <i>IF... THE ENGINE IS HOT</i> instructions in the <i>Starting and Stopping</i> section
THE ENGINE WILL NOT IDLE	
The air filter is dirty	Clean or replace the air filter
The fuel is old (over 30 days)	Drain the fuel tank and add fresh fuel
The idle speed is incorrect	Adjust the idle speed
THE ENGINE WILL NOT ACCELERATE	
The fuel is old (over 30 days)	Drain the fuel tank and add fresh fuel
The cutting head is bound with grass	Stop the engine and clean the cutting head
The air filter is dirty	Clean or replace the air filter
THE ENGINE LACKS POWER OR STALLS	
The fuel is old (over 30 days)	Drain the fuel tank and add fresh fuel
The air filter is dirty	Clean or replace the air filter
The spark plug is fouled	Replace the spark plug

NEED MORE HELP?

You'll find the answer and more on managemylife.com – for free!

- Find this and all your other product manuals online.
- Get answers from our team of home experts.
- Get a personalized maintenance plan for your home.
- Find information and tools to help with home projects.



brought to you by Sears

REPAIR PROTECTION AGREEMENTS

Congratulations on making a smart purchase. Your new Craftsman® product is designed and manufactured for years of dependable operation. But like all products, it may require repair from time to time. That's when having a Repair Protection Agreement can save you money and aggravation.

Here's what the Repair Protection Agreement* includes:

- ☑ **Expert service** by our 10,000 professional repair specialists
- ☑ **Unlimited service and no charge** for parts and labor on all covered repairs
- ☑ **Product replacement** up to \$1500 if your covered product can't be fixed
- ☑ **Discount of 25%** from regular price of service and related installed parts not covered by the agreement; also, 25% off regular price of preventive maintenance check
- ☑ **Fast help by phone** – we call it Rapid Resolution - phone support from a Sears representative. Think of us as a “talking owner's manual.”

Once you purchase the Repair Protection Agreement, a simple phone call is all that it takes for you to schedule service. You can call anytime day or night, or schedule a service appointment online.

The Repair Protection Agreement is a risk-free purchase. If you cancel for any reason during the product warranty period, we will provide a full refund. Or, a prorated refund anytime after the product warranty period expires. Purchase your Repair Protection Agreement today!

Some limitations and exclusions apply. For prices and additional information in the U.S.A. call 1-800-827-6655.

***Coverage in Canada varies on some items. For full details call Sears Canada at 1-800-361-6665.**

Sears Installation Service

For Sears professional installation of home appliances, garage door openers, water heaters, and other major home items, in the U.S.A. or Canada call **1-800-4-MY-HOME**.

Get it fixed, at your home or ours!

Your Home

For troubleshooting, product manuals and expert advice:



www.managemylife.com

For repair – **in your home** – of **all** major brand appliances, lawn and garden equipment, or heating and cooling systems, **no matter who made it, no matter who sold it!**

For the replacement parts, accessories and owner's manuals that you need to do-it-yourself.

For Sears professional installation of home appliances and items like garage door openers and water heaters.

1-800-4-MY-HOME[®] Call anytime, day or night

(1-800-469-4663)

(U.S.A. and Canada)

www.sears.com

www.sears.ca

Our Home

For repair of carry-in items like vacuums, lawn equipment, and electronics, call anytime for the location of the nearest

Sears Parts & Repair Service Center

1-800-488-1222 (U.S.A.)

1-800-469-4663 (Canada)

www.sears.com

www.sears.ca

To purchase a protection agreement on a product serviced by Sears:

1-800-827-6655 (U.S.A.)

1-800-361-6665 (Canada)

Para pedir servicio de reparación a domicilio, y para ordenar piezas:

1-888-SU-HOGAR[®]

(1-888-784-6427)

www.sears.com

Au Canada pour service en français:

1-800-LE-FOYER^{MC}

(1-800-533-6937)

www.sears.ca

sears

® Registered Trademark / TM Trademark of KCD IP, LLC in the United States, or Sears Brands, LLC in other countries

® Marca Registrada / TM Marca de Fábrica de KCD IP, LLC en Estados Unidos, o Sears Brands, LLC in otros países

MC Marque de commerce / ^{MD} Marque déposée de Sears Brands, LLC