

# Spec-Bar® Units

## ASSEMBLY INSTRUCTIONS

### CAUTION

INSPECT CONTENTS IMMEDIATELY AND FILE CLAIM WITH DELIVERING CARRIER FOR ANY DAMAGE.  
**SAVE YOUR BOX AND ALL PACKING MATERIALS.**  
YOU ARE RESPONSIBLE FOR DAMAGE TO YOUR UNIT IF RETURNED IMPROPERLY PACKED.

**Thank you for your purchase. Before assembly, read these instructions carefully.**  
**After reading, be sure to store in a safe place, should it be needed for future reference.**

NOTE: Units intended to be connected to a water supply system under pressure must be installed with adequate backflow protection to comply with applicable federal, state and local codes. NSF International requires that a screen of at least 100 mesh shall be installed immediately upstream of the backflow preventer. The screen shall be accessible and removable for cleaning or replacement.

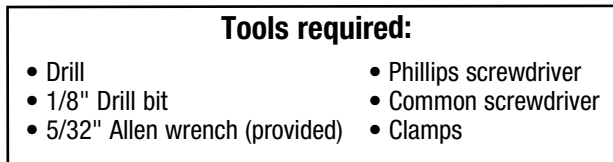
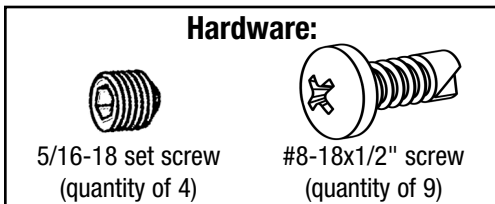

### Step 1 - Assemble crossbracing.

- Tighten set screws\*.

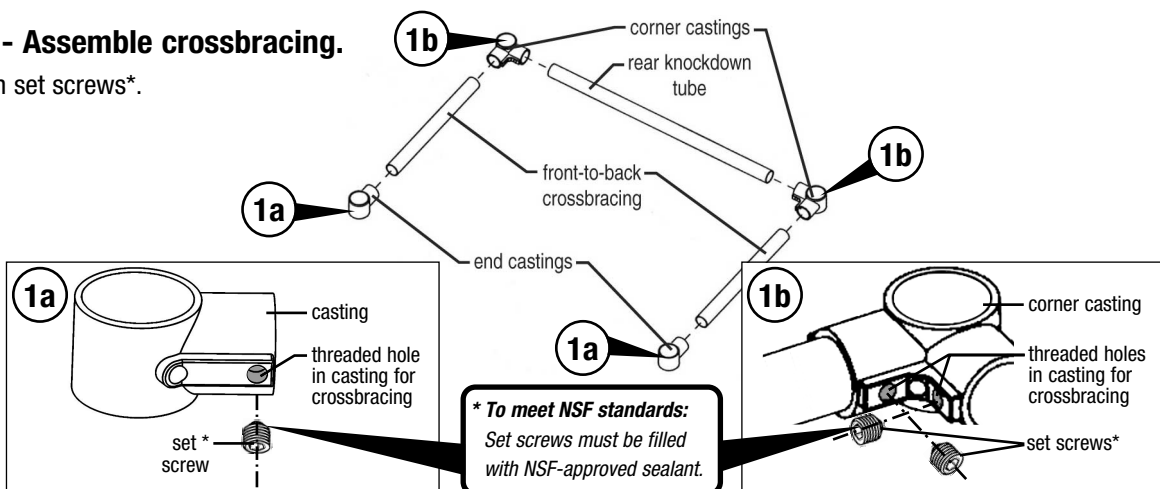

### Step 2 - Attach crossbracing to legs.

- On legs, measure and mark desired height\*\* of crossbracing.
- Insert leg through casting, stop at the mark you made. Repeat on remaining legs and castings.
- Snug the set screws\*.

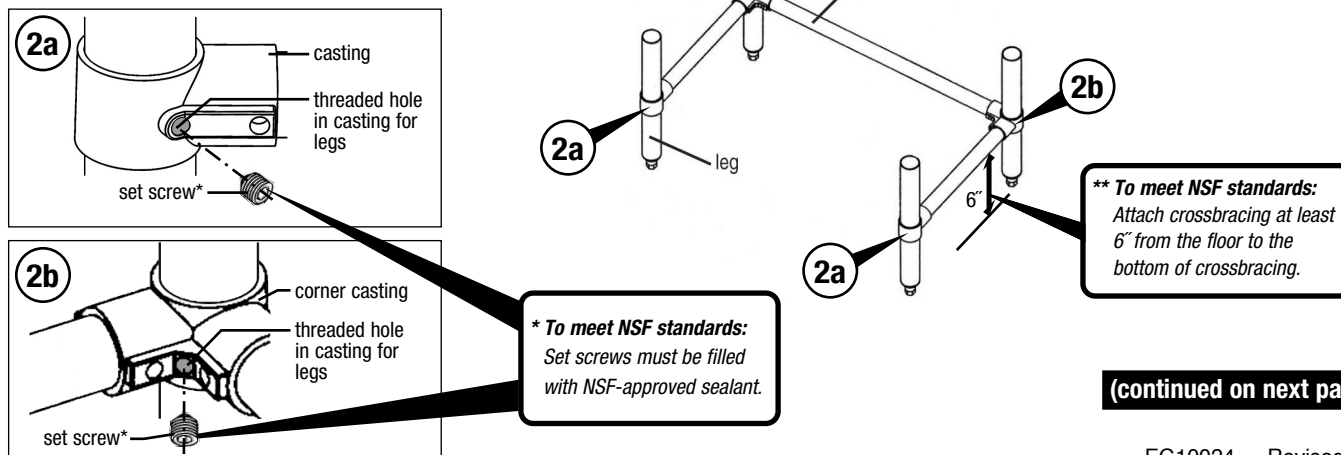

**(continued on next page)**

EG10024 Revised 06/23

# Spec-Bar® Units

## ASSEMBLY INSTRUCTIONS

**BEFORE CONTINUING...**

**If joining two or more units together, skip to page 3.**

### Step 3 - Assemble legs to underbar unit.

- Insert leg into each gusset of underbar unit.

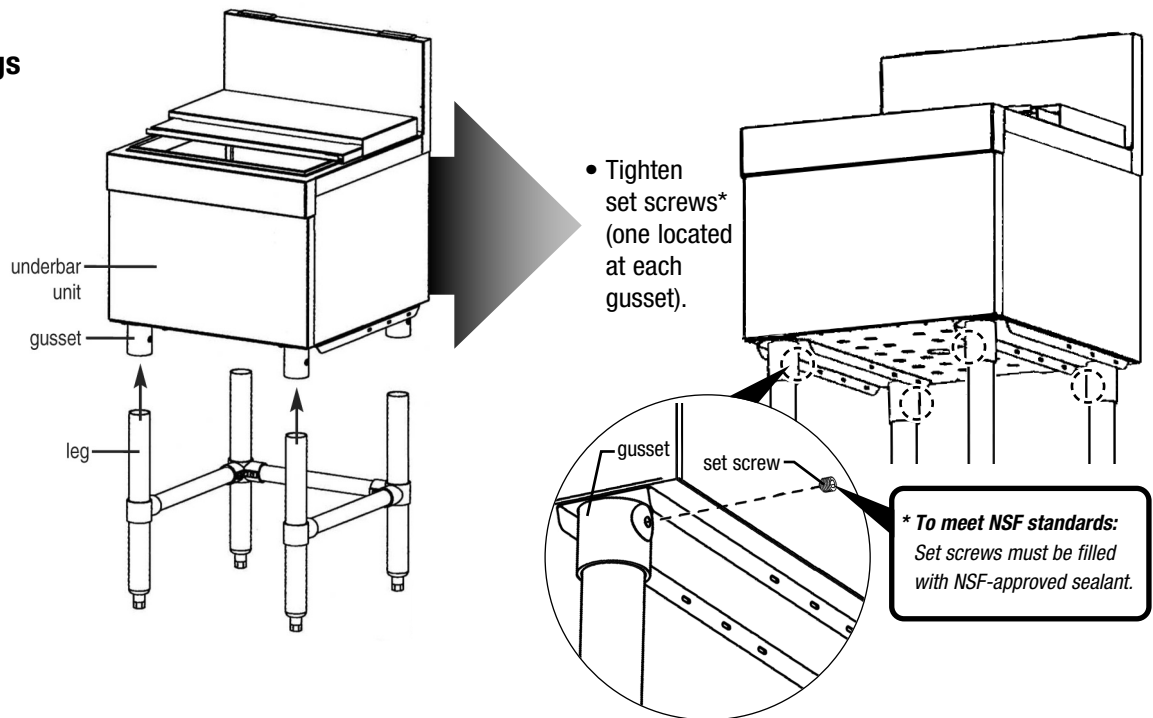

### Step 4 - Level underbar unit.

- Adjust height of unit by turning each leveling foot until unit is level.

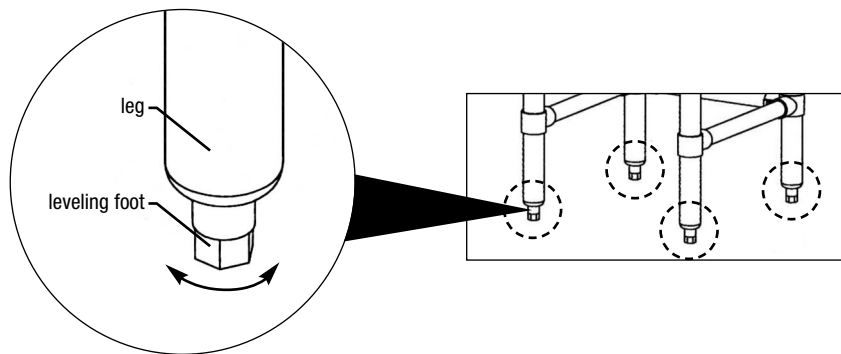

Assembly is complete.

**(End)**

# Spec-Bar® Units

## ASSEMBLY INSTRUCTIONS

If joining two or more units together,  
continue assembly by following these instructions...

### Step 3 - Attach bottom mounting plate.

- Carefully lay units onto their rear side on the floor, side-by-side.
- At bottom of units, position bottom mounting clip approximately midway along adjacent leg channels. Mark and drill holes into each leg channel.
- With the #8-18x1/2" drive screws provided, affix the bottom mounting clip to the leg channels (*figure 1*).
- Screw the bolts through the clip and leg channels, and apply the nut as shown in *figure 2*.

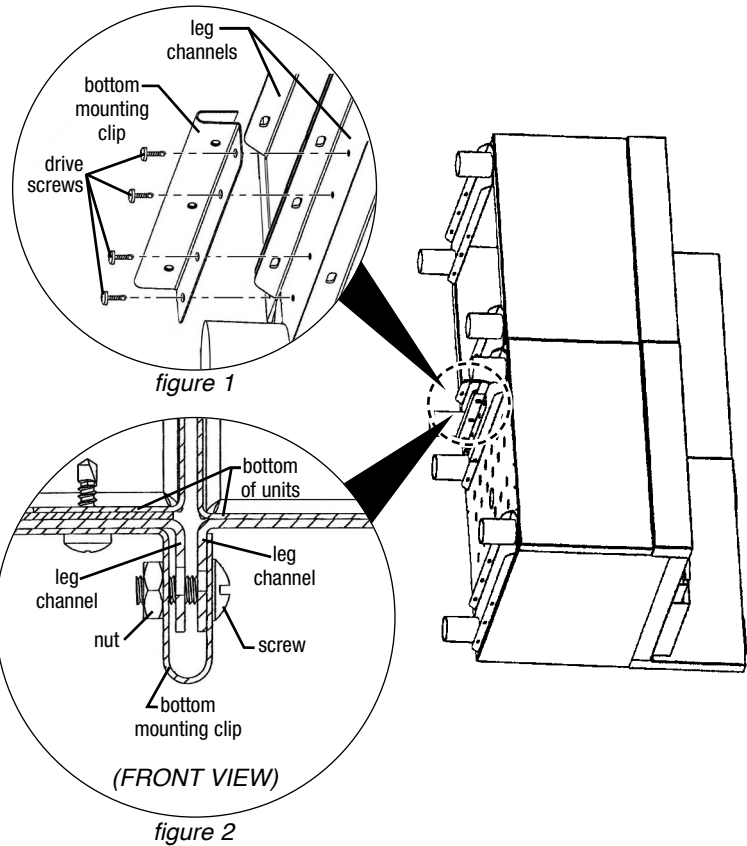

### Step 4 - Assemble crossbracing/leg assemblies to all underbar units.

*NOTE: On each assembly, make sure the end-to-end crossbracing is at the rear of unit, not the front.*

- Insert leg into each gusset of underbar units.
- Tighten all set screws\* (one located at each gusset).
- With assistance from a second person, carefully set units upright.

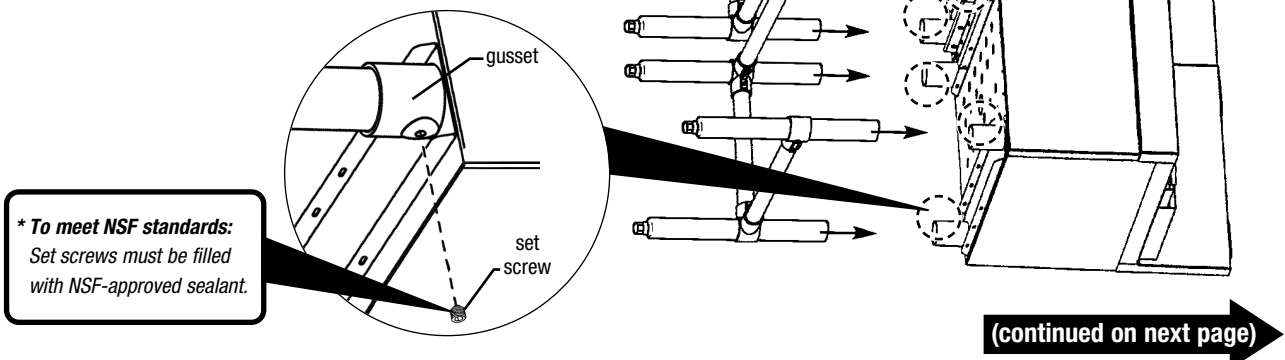

# Spec-Bar® Units

## ASSEMBLY INSTRUCTIONS

### Step 5 - Attach back plate.

- Position back plate approximately midway along adjacent return flanges. Mark and drill holes into each return flange.
- Make sure the units are tightly side-by-side along the back. A clamp (not included) can be used to pull the units together, if necessary.
- With the drive screws provided, screw the plate and the side panel return flanges together (*figure 4*).

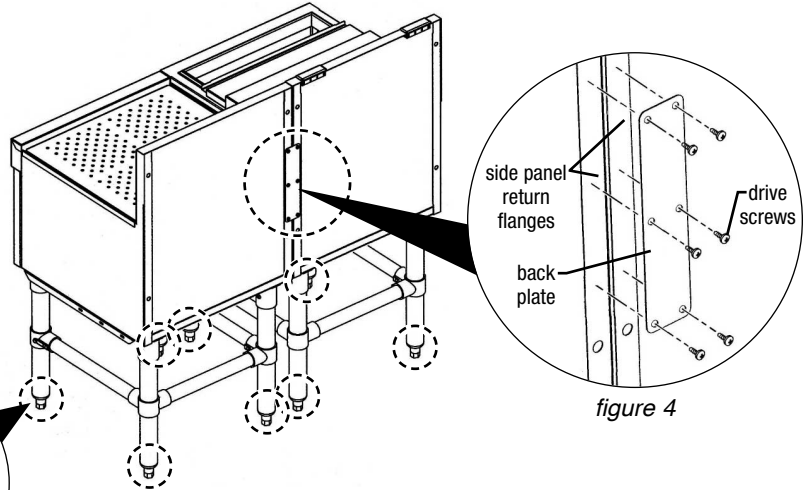

### Step 6 - Level all underbar units.

- Adjust height of units by turning each leveling foot until all units are level.

Assembly is complete.

(End)

### LIMITED WARRANTY

Metal Masters Foodservice Equipment Co Inc. d/b/a Eagle Group or Eagle Foodservice Equipment (“Eagle”) hereby warrants to you, the original purchaser and end-user (“you” or “your”), that the products manufactured by Eagle that you purchased which accompany this Limited Warranty (“products”) shall be free from defects in materials and workmanship under normal use consistent with the accompanying documentation for a period of one year from the date of the original installation of the equipment, not to exceed 18 months from date of shipment from Eagle. Some exclusions apply, outlined below are the product offerings that have their own individual warranty standards.

Warranty provided is limited to repair, replacement, or refund of the purchase price of the affected goods. Seller shall not be liable for any indirect, special, incidental, punitive, or consequential damages of any kind including loss of use, loss of revenue, or interruption of business.

Failure to have service work approved before work is performed shall not be covered under this warranty. Use of an unauthorized agency will void the warranty.

The warranty covers substantiated travel expenses for up to 2 hours or 100 miles round trip up to a maximum of \$150.00. Any additional costs due to installations that require extra work, time, or travel to gain access to service are the sole responsibility of the equipment purchaser. Any exceptions to these travel and access limitations must be pre-approved by the factory Service Manager.

Accessory items such as faucets, electronic eye faucets, drains, pre-rinse units are covered by a limited warranty of 90 days, unless individual manufacturer warranty allows for additional time.

Eagle also provides individual limited warranties concerning specific product categories.



- 100 Industrial Boulevard, Clayton, Delaware 19938-8903 U.S.A.
- Phone: 302/653-3000 • 800/441-8440 • Fax: 302/653-2065
- [www.eaglegrp.com](http://www.eaglegrp.com) • [www.eaglegrpnews.com](http://www.eaglegrpnews.com) • [www.eaglemhc.com](http://www.eaglemhc.com)