

WINIX

AIR PURIFIER



XQ Pro USER MANUAL

SPECIFICATIONS

Model	XQ Pro	Dimensions	14.6 in(W) × 14.6 in(D) × 31.3 in(H)
Voltage	AC120V/60Hz	Weight	30.86 lbs
Power Rate	90 W	Filter SKU	Filter X / SKU: 1712-0089-01
Verified Room Size	698 sq.ft.		

The exterior, design, and product specifications may be changed without prior notice to improve product performance.



Independently Tested
Consumer Trusted.

Contact Winix for product related inquiries and customer service

- Dedicated Call Center: ☎ (877) 699-4649
- Website: www.winixamerica.com



The energy efficiency of this ENERGY STAR certified model is measured based on a ratio between the model's CADR for smoke and the electrical energy it consumes, or CADR/Watt.

To expedite service, please specify the model name and number, the nature of the problem, your contact information, and your address.

- The product warranty is printed on the back of this guide.
- This product is manufactured for use only in North America.
- This product is suitable for 120V only.

SAFETY INSTRUCTIONS

Thank you for purchasing a Winix air purifier. This product is for household use only.

IMPORTANT CAUTIONS FOR USING YOUR AIR PURIFIER:

WARNING: Follow the instructions in this manual to reduce the risk of electric shock, short circuit, and/or fire.

- Do not repair or modify the unit yourself.
- All repairs should be completed by a qualified Winix technician.
- The plug for this unit is polarized with one blade wider than the other. Do not force the plug into an electrical outlet. Do not alter the plug in any way. If the plug does not fit into the outlet, reverse the plug. If it still does not fit, contact a qualified technician to install a proper outlet.
- Do not use if the power cord or plug is damaged or the connection to the wall outlet is loose.
- Use AC 120V only.
- Do not damage, break, forcefully bend, pull, twist, bundle, coat, pinch, or place heavy objects on the power cord.
- Periodically remove dust from the power plug. This will reduce the risk of shock due to humidity build up.
- Remove the power plug from the outlet before cleaning the unit. When removing the power plug, grasp by holding the plug itself, never hold by the cord.
- If the power plug is damaged, it must be replaced by the manufacturer or a qualified technician.
- Remove the power plug from the outlet when not in use.
- Do not handle the power plug with wet hands.
- Do not operate the unit when using indoor smoke-generating insecticides.
- Do not clean unit with benzene or paint thinner. Do not spray insecticides on the unit.
- Do not use the unit where it is humid or where the unit may become wet, such as the bathroom.
- Do not insert fingers or foreign objects into air intake or outlet.
- Do not use the unit near flammable gases. Do not use near cigarettes, incense, or other spark-creating items.
- Unit will not remove carbon monoxide emitted from heating appliances or other sources.
- Unplugging the product disconnects the remote functions.

IMPORTANT PRECAUTIONS FOR USING YOUR AIR PURIFIER

- Do not block the intake or outlet vents.
- Do not use near hot objects, such as a stove.
- Do not use where the unit may come into contact with steam.
- Do not use the unit on its side.
- Keep away from products that generate oily residue, such as a deep fryer.
- Do not use detergent to clean the unit.
- Do not operate without a filter.
- Do not wash and reuse the True HEPA Filter or the CD Carbon Filter.
- Hold the handle on the back of the unit to transport.
- Do not hold by the front panel.

SAFETY AND CAUTIONS

Before operating this equipment, carefully read and follow these safety cautions.

Ensure filters are inserted before running unit.

Running the unit without filters can shorten the lifespan of the unit and cause electric shock or injury.

Be sure foreign objects are NOT inserted into the vents on the unit.

Objects can include pins, rods, and coins.

Do not touch any part of the interior of the unit with wet hands.

The high voltage may cause electric shock.

Ensure unit intake and outlet vents do not become blocked.

Blockage may lead to increased internal temperatures, causing product failure and deformation.

Do not use the unit as a step stool or place heavy objects on the unit.

Personal injury may occur or product failure and deformation.



WARNING

Follow these instructions to reduce the risk of serious injury or death and to reduce risk of damaging the unit.

- If the power cord is damaged, it must be replaced by a special cord. Reassembly is available from the manufacturer or its service agent.
- This appliance is not intended for use by a person (including children) with reduced physical, sensory or mental capabilities, or lack of experience and knowledge of the unit, unless they have been given supervision or instruction concerning use of the appliance by a person responsible for their safety.
- Children should be supervised to ensure that they do not play with the appliance.
- This unit is not intended to be used to preserve documents or art conservation.



Do not pull on the power cord when unplugging the unit.



Do not tie or knot the power cord when unit is in operation.



If the unit becomes submerged in water, unplug it and contact customer service.



Do not unplug or move the unit while in operation.



Do not plug additional appliances into the same outlet or power supply.



Do not touch the plug with wet hands.



Unplug the unit when not in operation for extended periods of time.



Do not place around heating elements.



Do not use around mist or fumes from industrial oil or around large quantities of metallic dust.



The cord can become damaged by forcefully bending, pulling, twisting, bundling, pinching or placing heavy objects on it.



Do not install in any sort of motor or transport vehicle (trucks, boats, ships, etc.).



Do not place in an area with excessive amounts of noxious gases.



Do not place near any flammable materials (aerosols, fuel, gases etc.).



Do not have the unit facing into wind or drafts.



Do not place below any electrical outlet.



Do not place in excessively humid areas where the unit may become wet.



Do not place unit closer than 12 inches from the wall during operation. It may cause condensation on the wall and the surrounding area.

MODEL PART DIAGRAM

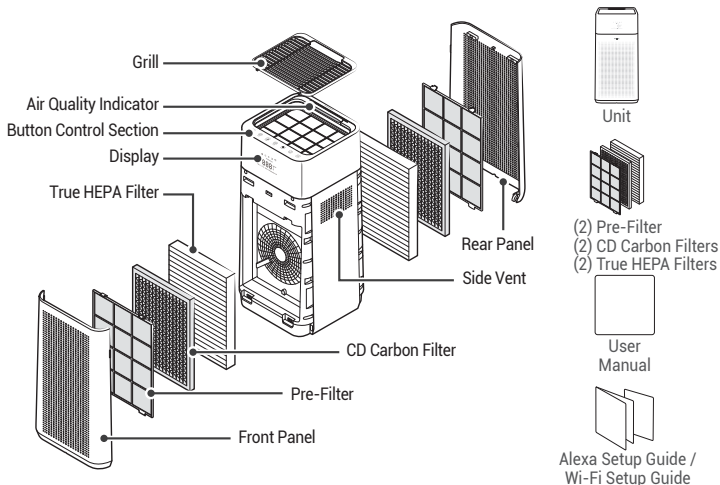

WHERE TO USE

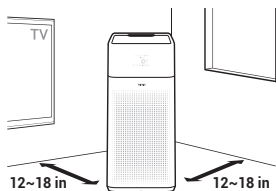

Allow 12 ~ 18 in. of space between TVs, radios, and other electronics

Electromagnetic interference from certain electronics may cause product malfunction.

Place indoors away from direct sunlight

Direct exposure may cause product malfunction or failure.

Only place on hard, flat surfaces

Flimsy or slanted surfaces may result in abnormal noise and vibrations.

Allow 12 ~ 18 in. from walls for maximum air flow

4-STAGE AIR PURIFICATION

Air Purification means it removes inanimate particles

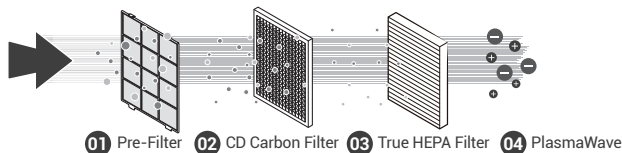

CONTROL PANEL

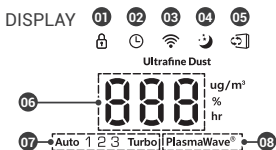

01. Child Lock Indicator

LED light indicates whether Child Lock mode is enabled or disabled.

02. Timer Indicator

If the timer has been set, the LED light indicates the set time of operation.

03. Wi-Fi Indicator

Indicates whether Wi-Fi Mode is enabled or disabled.

04. Sleep Mode Indicator

Indicates whether Sleep Mode is enabled or disabled.

05. Filter Replacement Indicator

LED light indicates when it is time to change the filter.

06. Ultrafine Dust Density Indicator

- The LED Ultrafine Dust Density Indicator displays the quality of air in your environment. When the unit senses an air quality change, it automatically adjusts the LED Indicator to display the respective air quality.
- LED Numeric Smart Sensor displays air quality measures fine particles down to 2.5 microns.

07. Mode Indicator

Indicates whether Auto & Fan Speed Mode is enabled or disabled.

08. PlasmaWave® Indicator

Indicates whether PlasmaWave® is enabled or disabled.

CONTROLS

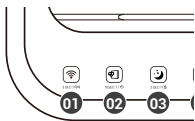

01. Wi-Fi / Pairing Button

- A quick press will turn Wi-Fi on/off.
- A long press of 3 seconds will activate pairing mode.
- A Wi-Fi indicator will display on the front while Wi-Fi is active.

02. Filter Life / Filter Reset Button

- A quick press will show the remaining filter life; indicated on the front display (100 ~ 0%).
- A long press of 10 seconds will reset the filter life indicator.
 - Use when replacing the filters.
 - Filter Reset Button can be used when the power is turned off.
 - The filter life will be reset to 100%.

03. Sleep Mode / Child Lock Button

- A quick press of the Sleep Mode / Child Lock Button cycles the unit in order from Sleep Mode General Mode Sleep Mode.
- In Sleep Mode, the Sleep Mode LED icon on the front indicator dims to 50% brightness. All other LEDs are turned off.
- If you press Sleep Mode / Child Lock Button for 3 seconds, Child Lock will be initiated and the buttons will not operate. A chime will sound if pressed.

04. PlasmaWave® Operation Button

- Turns the PlasmaWave® feature on/off.
- When the unit is running, you may hear a chirping or buzzing sound. The sound is from large particles passing through PlasmaWave®, it is normal and does not signify product failure.

05. Timer Button

- A quick press of the Timer Button will set the timer.
- The timer can be set in hours, in the order of 0(default) 1 2 4 8 12 0.
- The amount of time, in hours, is indicated on the front numeric display.
- Timer Indicator displays when timer is in use.

06. Fan Speed Button

- Enables manual operation of the unit's fan speeds.
- Press to cycle through and set the desired fan speed (Auto, Low, Medium, High, Turbo).
- Auto Mode:
 - Auto Mode automatically adjusts fan speeds according to your indoor air quality. The fan speed will adjust to low when air quality is good, medium when fair, and to high when poor.

07. Power Button

- Turns the unit on or off.
- During the first 30 seconds of powering up, the Air Quality Indicator will cycle through Blue, Green, Amber and Red colors. Smart Sensor takes approximately 4 minutes to detect the air quality in the environment before normal operation begins.

INITIAL OPERATION

1. Remove the front/rear panel by grasping its upper edge and gently pulling forward.
- To remove the front/rear panel, release the latch at the lower edge of the panel.
2. Remove the Pre-Filter, then the plastic bag of filters behind it.
3. Remove filters from protective plastic bag.
4. Install the filters until they fit securely in place.
03. True HEPA Filter (back)
02. CD Carbon Filter (middle)
01. Pre-Filter (front)
5. After filters are installed, close the front panel.
6. Insert the power cord into an electrical outlet.

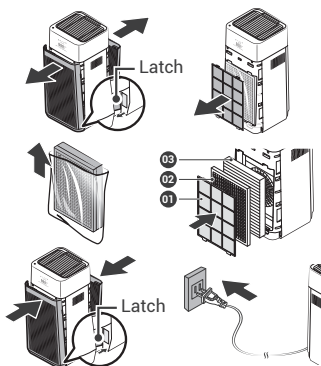

MAINTENANCE

When to Replace Filters

Filter	Indicator Light	When to Service	When to Replace
Pre-Filter	none	Clean once every 14 days	Permanent
CD Carbon Filter	 Check Filter	Can NOT be WASHED	Lasts Approx. 12 months
True HEPA Filter			

- When the Check Filter Indicator LED is on, it is time to replace the True HEPA Filter and CD Carbon Filter.
- Intervals between filter replacement may vary depending on environment.

REPLACING FILTERS

Uses **WINIX** Genuine Replacement Filter

Questions or Orders:
 (877)699-4649  info@winixinc.com
 or visit: www.winixamerica.com

ITEM: 1712-0089-01



10SEC 

Resetting Filter Life:

After replacing your True HEPA Filter, place the Pre-Filter back in and close the Front Panel. While the unit is on, hold the Filter Reset Button for at least 5 seconds until you hear the beep. After the beep, the Filter Replacement Indicator will disappear. Your Winix True HEPA is now reset.

CLEANING CARE

Cleaning the Filters:

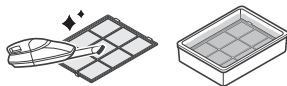

Use a vacuum cleaner or soft brush to clean the Pre-Filter

- If it is excessively soiled, rinse in room temperature water.
- Do not use detergent or soap.
- Allow the filter to dry for 24 hours or more before using.
- Intervals between filter cleaning may vary depending on the air quality in the environment.

Cleaning the Smart Sensor:

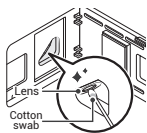

1. Use a damp cotton swab to wipe the lens and intake area of the Smart Sensor.
 - To clean the sensor area, use only water. Do not use volatile substances such as alcohol or acetone.

2. Wipe away any remaining moisture with a dry cotton swab.



NOTICE

- Do not use benzene, alcohol, or other volatile fluids, which may cause damage or discoloration.
- Do not use hot water over 104 .

Cleaning the Exterior & Interior:

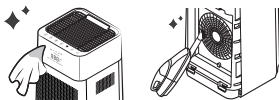

1. Open the front panel and clean the interior with a vacuum cleaner.
 - A handheld vacuum or hose attachment will work best.
 2. Dampen a cloth with room temperature water and wipe down the interior and exterior of the unit.
 3. Wipe the unit down with a clean, dry cloth.
 - Ensure no moisture remains before plugging the unit back in.
- * For optimal performance, clean every 1 - 2 months.

Cleaning the Top:



1. Grasp the back of the grill and lift up.
2. Wipe the interior and grill with a soft, damp cloth.
3. To reinstall the grill, insert the two front tabs of the grill into the corresponding holes in the product.



NOTICE

- When cleaning the unit, always unplug the power cord first and then wait until the unit has cooled down.
- Never disassemble, repair, or modify this unit yourself.
- Do not use flammable sprays or liquid detergents.
- Do not allow children to clean or maintain the unit.
- Before cleaning or maintaining, ensure unit is unplugged.

TWO YEARS WARRANTY

The terms of the warranty are as follows:

1. This product is manufactured under stringent quality control and inspections.
2. The warranty will be voided if product failure is a result of negligence or misuse by the consumer.
3. A proof of purchase must be presented upon claiming a Product Warranty.
4. Store the proof of purchase in a safe place or register your product on winixamerica.com to upload your proof of purchase.
5. This warranty is valid only in the USA and Canada.

* for more information visit

<https://winixamerica.com/terms-and-conditions/>

Product Name		Air Purifier
Model Name		XQ Pro
Purchase Date		
Warranty Period		Two (2) Years
Place of Purchase		
Place of Purchase tel.		
Customer	Address	
	Name	
	Tel.	

After purchase, be sure to complete all of the above information.

Warning: Changes or modifications to this unit not expressly approved by the party responsible for compliance could void the user's authority to operate the equipment.

Note: This equipment has been tested and found to comply with the limits for a Class B digital device, pursuant to Part 15 of the FCC Rules. These limits are designed to provide reasonable protection against harmful interference in a residential installation. This equipment generates, uses and can radiate radio frequency energy and, if not installed and used in accordance with the instructions, may cause harmful interference to radio communications. However, there is no guarantee that interference will not occur in a particular installation. If this equipment does cause harmful interference to radio or television reception, which can be determined by turning the equipment off and on, the user is encouraged to try to correct the interference by one or more of the following measures:

- Reorient or relocate the receiving antenna.
- Increase the separation between the equipment and receiver.
- Connect the equipment into an outlet on a circuit different from that to which the receiver is connected.
- Consult the dealer or an experienced radio/TV technician for help.

This device contains license-exempt transmitter(s)/receiver(s) that comply with Innovation, Science and Economic Development Canada's license-exempt RSS(s). Operation is subject to the following two conditions:

- This device may not cause interference.
- This device must accept any interference, including interference that may cause undesired operation of the device.

"In French: Cet appareil contient des émetteurs/récepteurs exemptés de licence et conformes aux normes Innovation, Science et Economic. RSS(s) sans licence de Développement Canada. Le fonctionnement est soumis aux deux conditions suivantes:

- cet appareil ne doit pas causer d'interférences nuisibles, et
- cet appareil doit accepter toute interférence reçue, y compris les interférences pouvant provoquer un fonctionnement non souhaité."