

ADCRAFT®



CP-40, CP-60, CP-100 Coffee Percolators

This manual contains important information regarding your *Admiral Craft* unit. Please read this manual thoroughly prior to equipment set-up, operation and maintenance. Failure to comply with regular maintenance guidelines outlined in this manual may void the warranty. MUST READ!!!

WARNINGS

- Do not touch any hot surfaces
- Do not immerse unit, cord or plug in liquid at any time
- Unplug cord from outlet when not in use and before cleaning
- Plug only into a 3-hole grounded electrical outlet
- Do not operate unattended
- Do not use this unit for anything other than intended use
- Do not use outdoors
- Always use on a firm, dry and level surface at least 12” from walls or any other obstruction
- Do not use if unit has a damaged cord or plug, in the event the appliance malfunctions, or has been damaged in any manner
- Keep children and animals away from unit
- Any incorrect installation, alterations, adjustments and/or improper maintenance can lead to property loss and injury. All repairs should be done by authorized professionals only
- Ensure that the designated power supply is adequate for continual usage and the voltage is correct
- Scalding may occur if the lid is removed during the brewing cycle.

TO USE

1. Clean the filter basket, cover, percolator tube and the inside of the tank with a non- abrasive detergent.
2. Pour cool water into the urn to fill at least half of the total capacity of the urn.
3. Cover the filter basket with the basket cover.
4. Center the percolator tube into the basket and tray. Make sure that the base of the tube is positioned securely in the well of the urn.
5. Center the filter basket into the percolator tube and place ground coffee in the basket. Put the basket cover back on and put the cover on the urn.
6. Plug the cord into your electrical outlet and turn the power switch on. The switch will light up.
7. When the indicator lamp lights up the brewing process is complete.
8. The second heating system will start to operate automatically to keep the coffee warm.
9. When there are only about 3 cups of coffee left in the urn, turn the power switch off and unplug the cord from the outlet.
10. To reheat cold coffee in the urn, there must be at least 12 cups of coffee in the tank to reheat. Simply re-plug the cord back into the electrical outlet and turn the power switch on.

SEDIMENT REMOVAL

*On areas of the heating element, hard water will cause chalk and limestone to accumulate over time. It is recommended that you clean the percolator and remove the residue.

1. Pour 100 ml. of fresh lemon juice into the urn body
2. Wait 5-6 minutes to allow the lemon juice to run through the sediments
3. You can use a soft bristle brush to clean the heating element
4. Repeat steps 1-3 until limestone is removed
5. Use a dry cloth to wipe the residual liquid
6. Pour clean water into the urn until and rinse until lemon smell is gone

Parts – please check prior to installation

1. Cover
2. Urn
3. Level Indicator
4. Faucet
5. Power Switch
6. Indicator Lamp
7. Urn Base
8. Basket Cover
9. Filter Basket
10. Basket Tray – not included on CP-40
11. Percolator Tube
12. Cord
13. Bottom of Urn
14. Heating Element

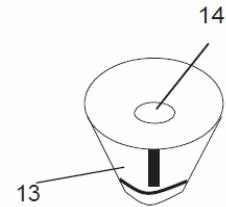
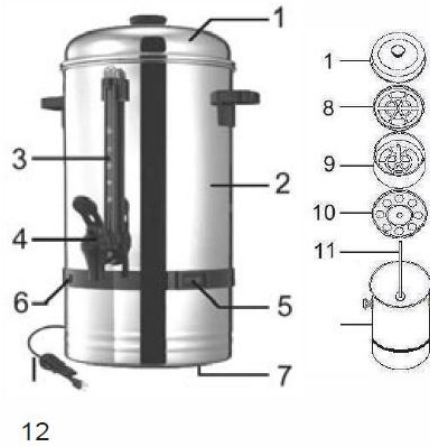

TROUBLESHOOTING - Troubles listed are for reference. If any fault occurs, please discontinue use. Do not attempt to repair yourself. This will void the warranty.

UNDER NO CIRCUMSTANCES SHOULD THIS UNIT BE OPERATED DRY. IT IS ALSO NOT INTENDED TO SIMPLY BOIL WATER.

Problem	Cause	Solution
Not working as well as expected	Unit is not on a dedicated circuit	Unplug unit, plug into a dedicated line and retry
Leaking from the area where the spigot attaches to the urn	Nut/bolt is loose	Inside the urn, there is a nut/bolt that may loosen over time. Tighten the nut/bolt and leaking will stop.
Leaking from the area where the spigot attaches to the graduation	The fitting under the graduation water indicator has become loose	Tighten the small black fitting underneath the water indicator and the leaking will stop.
Leaking from the area where the spigot lever and spout meet	The area is loose	Twist the lever to tighten and the leaking will stop.

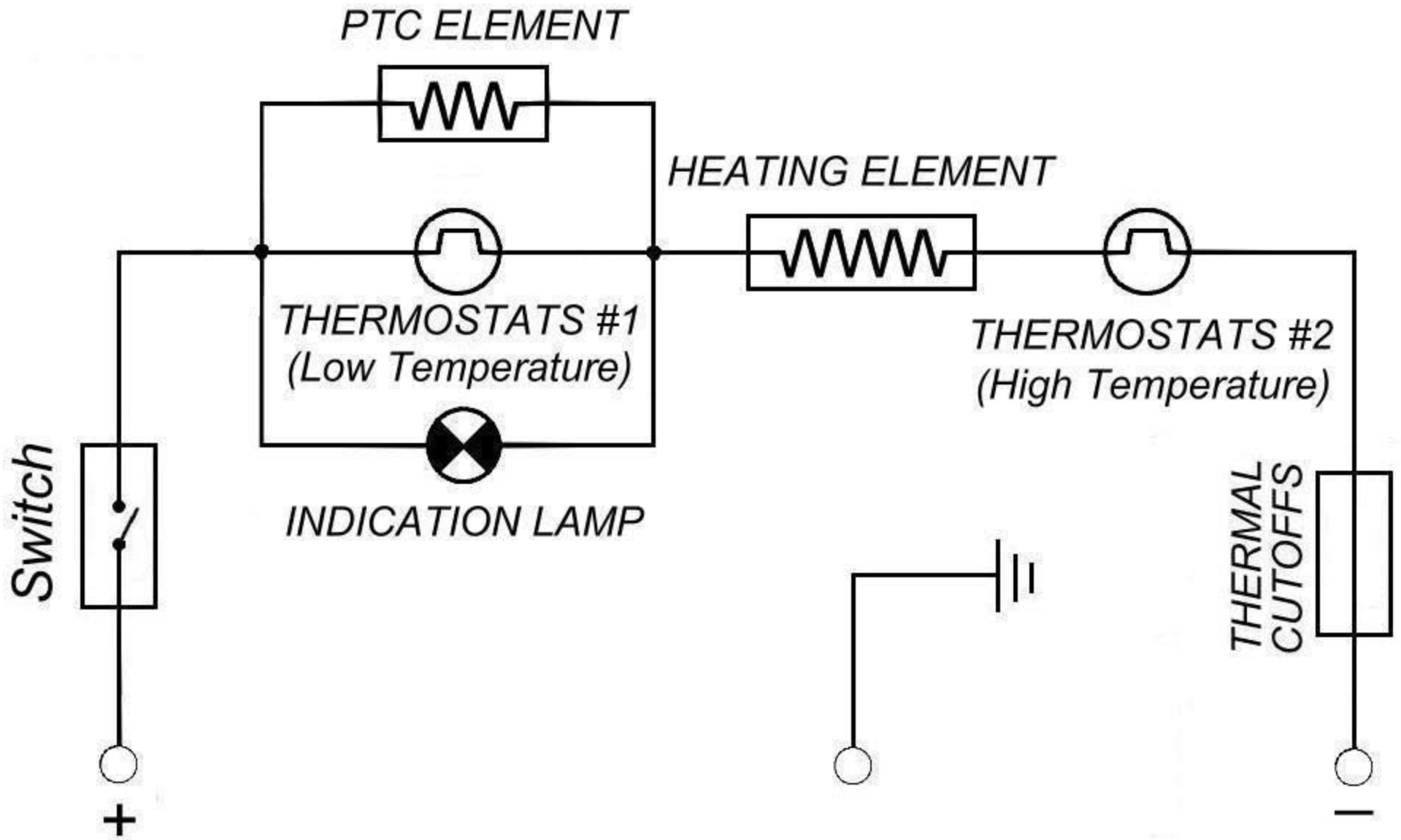

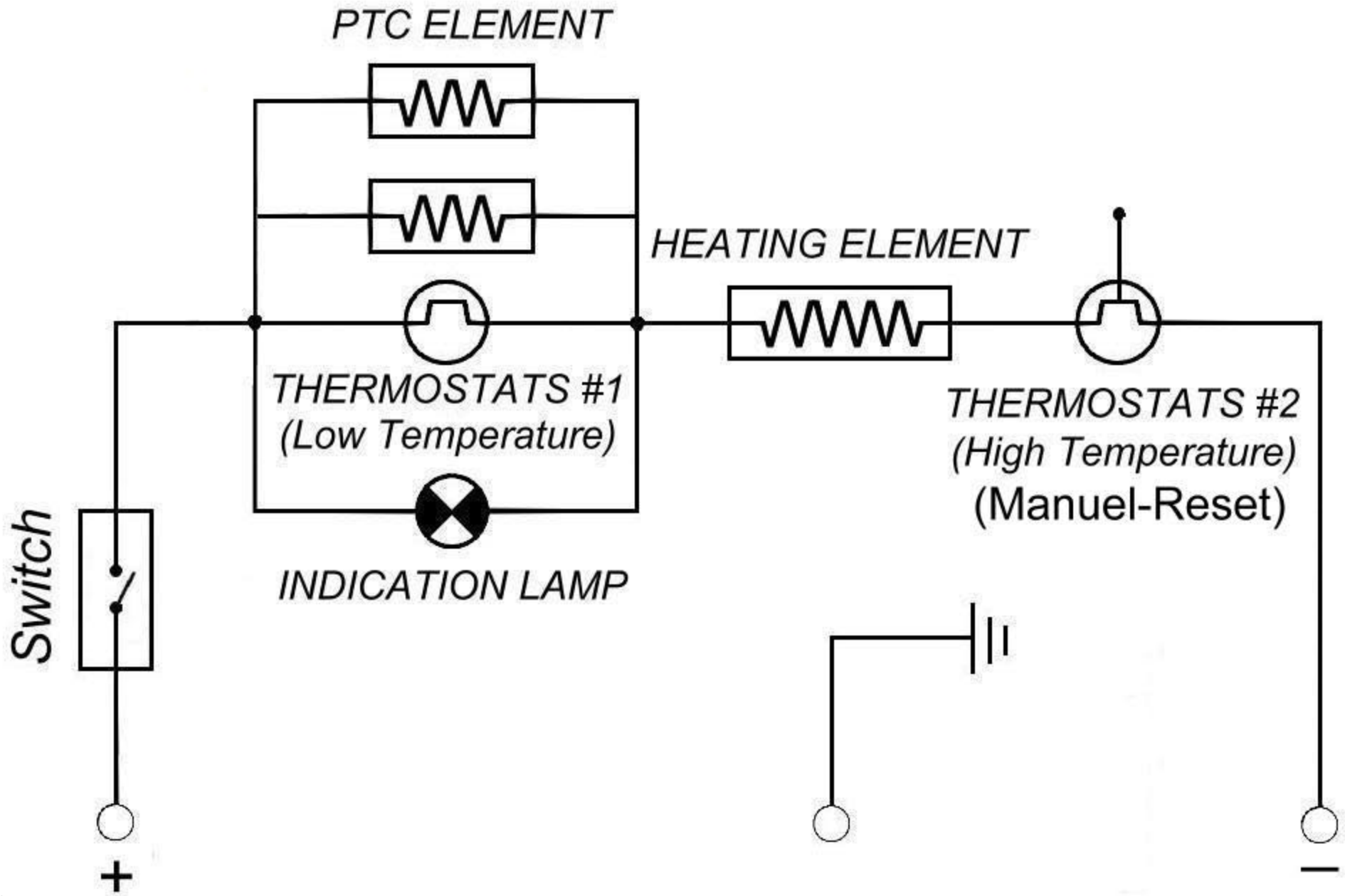

CP-40
CP-60
CP-100

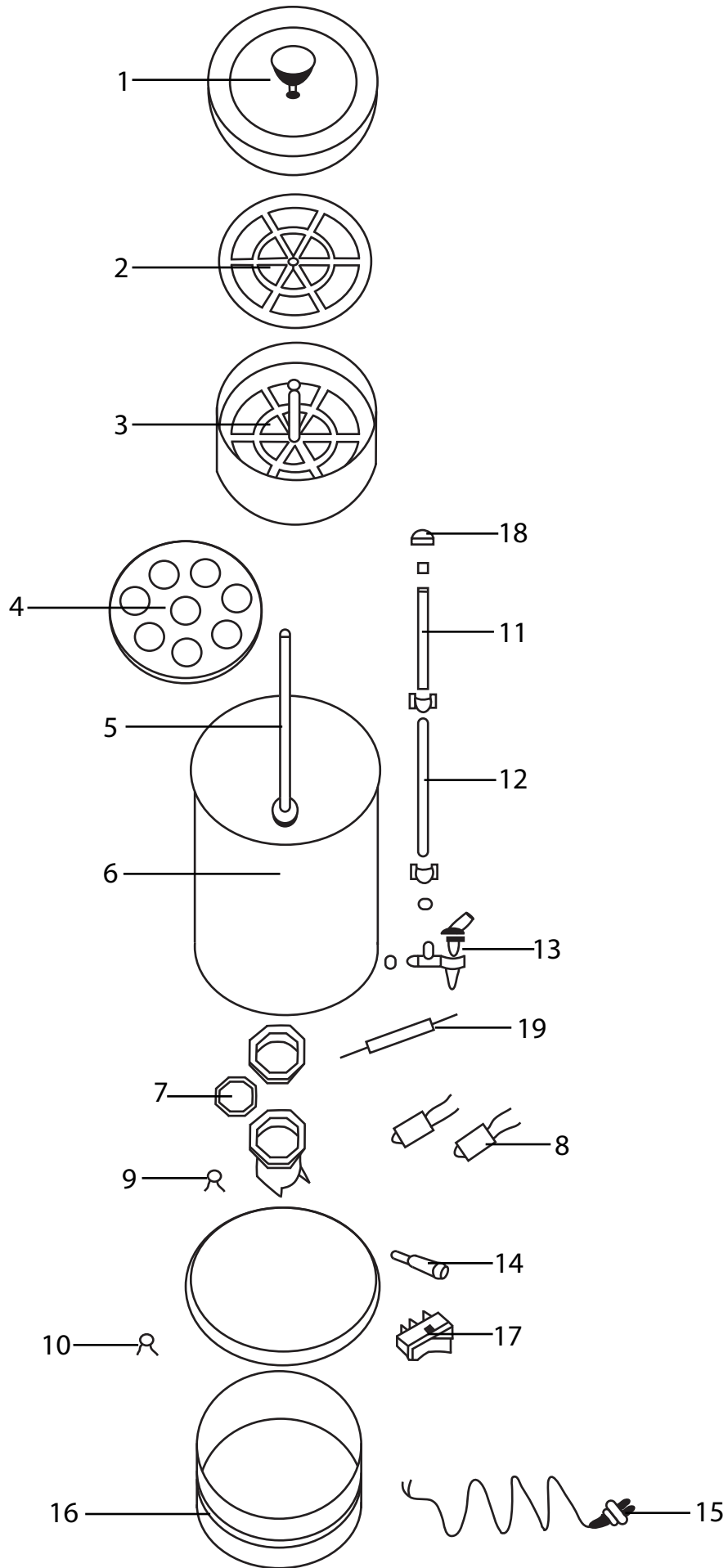

VER811



Coffee Percolators - CP-40, CP-60, CP-100

Reference Number	CP-40 Part Number	CP-60 Part Number	CP-100 Part Number	Description
1	CP4-1	CP-01	CP-01	Cover with Knob
2	CP4-2	CP-02	CP-02	Basket Cover
3	CP4-3	CP-03	CP-03	Basket
4	CP4-4	CP-04	CP-04	Basket Base
5	CP4-5	CP6-5	CP1-5	Stem
14	CBCP-6	CBCP-6	CBCP-6	Indicator Light - Red
7	CP-7	CP-7	CP-7	High Heat Element
8	CP-8	CP-8	CP-8	Low Heat Element
9	CP-9	CP-9	CP-9	Thermostat High Temp
10	CP-10	CP-10	CP-10	Thermostat Low Temp
11	CP4-11	CP6-11	CP1-11	Glass Graduation
12	CP4-12	CP6-12	CP1-12	Sleeve for Graduation
13	CP-13	CP-13	CP-13	Spigot
15	CP-15C	CP-15C	CP-15C	Power Cord and Strain Relief
16	na	na	na	Base
17	CP-17	CP-17	CP-17	Lighted Switch - Red
18	CP-18	CP-18	CP-18	Screwcap for Sleeve
19	CP-19	CP-19	CP-19	Thermal Cutoff

VER811

ACE Equipment One Year Limited Warranty

Admiral Craft Equipment Corp. (ACE) warrants its equipment against defects in materials and workmanship, subject to the following conditions:

ACE Equipment is warranted for one year, effective from the date of purchase by the original owner. A copy of the original receipt or other proof of purchase is required to obtain warranty coverage. This warranty applies to the original owner only, and is not assignable.

Should any product fail to function in its intended manner under normal use within the limits defined in this warranty, at ACE's discretion, such product will be repaired, replaced with a refurbished unit, or replaced with a new unit by ACE, after defective unit has been inspected and defect has been confirmed. ACE does not assume any liability for extended delays in replacing any item beyond its control. This warranty does not apply to rubber and non-metallic synthetic parts that may need to be replaced due to normal usage, wear or lack of preventative maintenance.

This warranty covers products shipped into the 48 contiguous United States, Hawaii, and metropolitan areas of Alaska and Canada. Warranty coverage on products used outside the 48 contiguous United States, Hawaii and metropolitan areas of Alaska and Canada may vary. Contact ACE for details at 1-800-223-7750

The following conditions are not covered by warranty:

- Equipment failure relating to improper installation, improper utility connection or supply and problems due to improper ventilation.
- Equipment that has not properly been maintained, damage from improper cleaning, and water damage to controls.
- Equipment that has not been used in an appropriate manner, or has been subject to misuse, neglect, abuse, accident, alteration, negligence, damage during transit, delivery or installation, fire, flood, riot, or act of God.
- Equipment that has the model number or serial number removed or altered.
- Equipment on which the security seal has been broken.

If the equipment has been changed, altered, modified, or repaired without express written permission from ACE, then the manufacturer shall not be liable for any damages to any person or to any property, which may result from the use of this equipment thereafter.

This equipment is intended for commercial use only and this warranty is void if equipment is used in other than a commercial application.

For warranty and non-warranty related issues please call ACE at 1-800-223-7750 ext 3 to speak to technical support. When calling please have your model number, serial number and proof of purchase ready. To purchase replacement parts, receive online technical support or fill out a warranty claim visit www.admiralcraftequipment.com. It is not necessary to contact the place where you originally purchased your product from.

“THE FOREGOING WARRANTY IS IN LIEU OF ANY AND ALL WARRANTIES EXPRESSED OR IMPLIED INCLUDING ANY IMPLIED WARRANTY OF MERCHANTABILITY OR FITNESS FOR PARTICULAR PURPOSES AND CONSTITUTES THE ENTIRE LIABILITY OF ACE. IN NO EVENT DOES THE LIMITED WARRANTY EXTEND BEYOND THE TERMS STATED HEREIN.”