

# Use and Care Guide



## KITCHENAID® Upper Microwave Oven with Convection and/or Broil Element

**KitchenAid®**  
FOR THE WAY IT'S MADE®

<b>A Note to You</b> .....	2
<b>Microwave Oven Safety</b> .....	3
<b>Getting to Know Your Microwave Oven</b> .....	6
How your microwave oven works .....	6
Radio interference .....	6
For best cooking results .....	6
Testing your microwave oven .....	6
Testing your dinnerware or cookware .....	7
Operating tips .....	7
Electrical connection .....	7
Parts and features .....	8
Control panel features .....	9
Utensils .....	11
Setting the clock .....	12
Using the Minute Timer .....	13
Using EASY MINUTE .....	13
<b>Microwave Cooking</b> .....	14
Cooking at high cook power .....	14
Cooking at different cook powers .....	15
Cooking in stages .....	16
Using CUSTOM REHEAT .....	17
Using CUSTOM DEFROST .....	20
Defrosting tips .....	22
Popping popcorn .....	23
Using CUSTOM COOK .....	23
Custom Cook Chart .....	24
Keeping food warm .....	25
<b>Cooking with CRISP and BROIL</b> .....	26
To get the best cooking results .....	26
Using CRISP .....	26
Using BROIL .....	27
<b>Cooking with CONVECT</b> .....	28
Using CONVECT .....	28
CONVECT cooking with QUICK PREHEAT .....	28
CONVECT cooking without preheat .....	29
<b>Cooking Guide</b> .....	30
<b>Caring for Your Microwave Oven</b> .....	36
<b>Questions and Answers</b> .....	37
<b>Troubleshooting</b> .....	39
<b>Requesting Assistance or Service</b> .....	40
<b>Warranty</b> .....	44

In the U.S.A. for assistance or service,  
call the Consumer Assistance Center:

1-800-422-1230

In Canada for assistance or service,  
see page 41.

Models: KEMS307G KEMS377G KBMC147H  
KEMS308G KEMS378G KBMC140H

4452614

[www.kitchenaid.com](http://www.kitchenaid.com)

# A Note to You

*Thank you for buying a KITCHENAID® appliance!*

Because your life is getting busier and more complicated, KitchenAid® appliances are easy to use, save time, and help you manage your home better. To ensure that you enjoy many years of trouble-free operation, we developed this Use and Care Guide. It contains valuable information concerning how to operate and maintain your new appliance properly and safely. Please read it carefully. Also, please complete and mail the enclosed Product Registration Card.

## Please record your model's information.

Whenever you call our Consumer Assistance Center at **1-800-422-1230** (in Canada, **1-800-461-5681**) or request service for your appliance, you need to know your complete model number and serial number. You can find this information on the model and serial number plate (located on the lower oven ).

Please also record the purchase information.

**NOTE:** You must provide proof of purchase or installation date for in-warranty service.

**Keep this book and the sales slip together in a safe place for future reference.**

**Model Number** \_\_\_\_\_

**Serial Number** \_\_\_\_\_

**Purchase/  
Installation Date** \_\_\_\_\_

**Builder/Dealer  
Name** \_\_\_\_\_

**Address** \_\_\_\_\_

**Phone** \_\_\_\_\_

# Microwave Oven Safety

## Your safety and the safety of others is very important.

We have provided many important safety messages in this manual and on your appliance. Always read and obey all safety messages.



This is the safety alert symbol.

This symbol alerts you to hazards that can kill or hurt you and others.

All safety messages will be preceded by the safety alert symbol and the word "DANGER" or "WARNING." These words mean:

**! DANGER**

You will be killed or seriously injured if you don't follow instructions.

**! WARNING**

You can be killed or seriously injured if you don't follow instructions.

All safety messages will identify the hazard, tell you how to reduce the chance of injury, and tell you what can happen if the instructions are not followed.

## IMPORTANT SAFETY INSTRUCTIONS

When using electrical appliances basic safety precautions should be followed, including the following:

**WARNING:** To reduce the risk of burns, electric shock, fire, injury to persons, or exposure to excessive microwave energy:

- Read all instructions before using the microwave oven.
- Read and follow the specific "PRECAUTIONS TO AVOID POSSIBLE EXPOSURE TO EXCESSIVE MICROWAVE ENERGY" found in this section.
- The microwave oven must be grounded. Connect only to properly grounded outlet. See "GROUNDING INSTRUCTIONS" found in the "Installation Instructions" section and on page 5 of this manual.
- Install or locate the microwave oven only in accordance with the provided Installation Instructions.
- Some products such as whole eggs in the shell and sealed containers – for example, closed glass jars – may explode and should not be heated in the microwave oven.
- Use the microwave oven only for its intended use as described in this manual. Do not use corrosive chemicals or vapors in the microwave oven. This type of oven is specifically designed to heat, cook, or dry food. It is not designed for industrial or laboratory use.
- As with any appliance, close supervision is necessary when used by children.
- Do not operate the microwave oven if it has a damaged cord or plug, if it is not working properly, or if it has been damaged or dropped.

**SAVE THESE INSTRUCTIONS**

continued on next page



## IMPORTANT SAFETY INSTRUCTIONS

- The microwave oven should be serviced only by qualified service personnel. Call an authorized service company for examination, repair, or adjustment.
- See door surface cleaning instructions in the “Caring for Your Microwave Oven” section.
- To reduce the risk of fire in the oven cavity:
  - Do not overcook food. Carefully attend the microwave oven if paper, plastic, or other combustible materials are placed inside the oven to facilitate cooking.
  - Remove wire twist-ties from paper or plastic bags before placing bags in oven.
  - If materials inside the oven should ignite, keep oven door closed, turn oven off, and disconnect the power cord, or shut off power at the fuse or circuit breaker panel.
  - Do not use the cavity for storage purposes. Do not leave paper products, cooking utensils, or food in the cavity when not in use.

## SAVE THESE INSTRUCTIONS

## PRECAUTIONS TO AVOID POSSIBLE EXPOSURE TO EXCESSIVE MICROWAVE ENERGY...

- (a) Do not attempt to operate this oven with the door open since open-door operation can result in harmful exposure to microwave energy. It is important not to defeat or tamper with the safety interlocks.
- (b) Do not place any object between the oven front face and the door or allow soil or cleaner residue to accumulate on sealing surfaces.
- (c) Do not operate the oven if it is damaged. It is particularly important that the oven door close properly and that there is no damage to the:
  - (1) Door (bent),
  - (2) Hinges and latches (broken or loosened),
  - (3) Door seals and sealing surfaces.
- (d) The oven should not be adjusted or repaired by anyone except properly qualified service personnel.



## GROUNDING INSTRUCTIONS

- **For all cord connected appliances:**

The microwave oven must be grounded. In the event of an electrical short circuit, grounding reduces the risk of electric shock by providing an escape wire for the electric current. The microwave oven is equipped with a cord having a grounding wire with a grounding plug. The plug must be plugged into an outlet that is properly installed and grounded.

**WARNING:** Improper use of the grounding plug can result in a risk of electric shock.

Consult a qualified electrician or serviceman if the grounding instructions are not completely understood, or if doubt exists as to whether the microwave oven is properly grounded.

Do not use an extension cord. If the power supply cord is too short, have a qualified electrician or serviceman install an outlet near the microwave oven.

- **For a permanently connected appliance:**

The microwave oven must be connected to a grounded, metallic, permanent wiring system, or an equipment grounding conductor should be run with the circuit conductors and connected to the equipment grounding terminal or lead on the microwave oven.

## SAVE THESE INSTRUCTIONS

# Getting to Know Your Microwave Oven

This section discusses the concepts behind microwave cooking. It also shows you the basics you need to know to operate your microwave oven. Please read this information before you use your oven.

## How your microwave oven works

**Microwave ovens are safe.** Microwave energy is not hot. It causes food to make its own heat, and it's this heat that cooks the food.

Microwaves are like TV waves, radio waves or light waves. You cannot see them, but you can see what they do.

A **magnetron** in the microwave oven produces microwaves. The microwaves move into the oven where they contact food as it turns on the turntable.

The **glass turntable** of your microwave oven lets microwaves pass through. Then they bounce off a metal floor, back through the glass turntable, and are absorbed by the food.

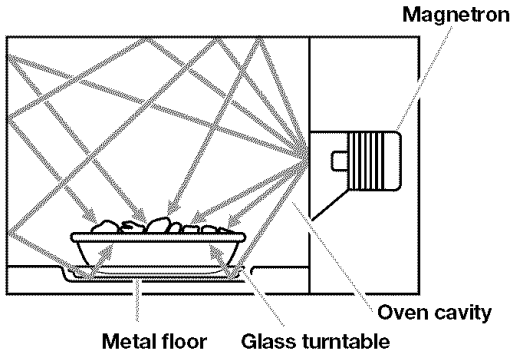

**Microwaves** pass through most glass, paper, and plastics without heating them so food absorbs the energy. Microwaves bounce off metal containers so food does not absorb the energy.

The microwaves disturb water molecules in the food. As the molecules bounce around bumping into each other, heat is made, like rubbing your hands together. This is the heat that does the cooking.

**Microwaves do heat the CRISPWARE™ Crisper Pan, however.** The rubberized pad on the bottom of the Crisper Pan is made of a special material which absorbs microwaves. This heats the pan very rapidly, browning and crisping the bottom of the food.

The **Crisper Pan** reaches 436°F (210°C) in about 2 minutes (faster than a browning dish) and stays at that temperature. The bottom coating of the Crisper Pan is designed to stop absorbing microwaves at 436°F (210°C), which is the best temperature for frying.

## Radio interference

Using your microwave oven may cause interference to your radio, TV, or similar equipment. When there is interference, you can reduce it or remove it by:

- **Cleaning** the door and sealing surfaces of the oven.
- **Adjusting** the receiving antenna of the radio or television.
- **Moving** the receiver away from the microwave oven.

## For the best cooking results

- **Always cook food** for the shortest cooking time recommended. Check to see how the food is cooking. If needed, touch the EASY MINUTE while the oven is operating or after the cooking cycle is over (see the "Using EASY MINUTE" section).
  - **Stir, turn over, or rearrange** the food being cooked about halfway through the cooking time for all recipes. This will help make sure the food is evenly cooked.
- NOTE:** Some cycles may have to be reset if you have interrupted the cycle.
- **If you do not have a cover for a dish,** use wax paper, or microwave-approved paper towels or plastic wrap. Turn back a corner of the plastic wrap to vent steam during cooking.

## Testing your microwave oven

To test the oven put about 1 cup (250 mL) of cold water in a glass container in the oven. Close the door. Make sure it latches. Cook at 100% power for 2 minutes. When the time is up, the water should be heated.



---

## Testing your dinnerware or cookware

**Test dinnerware or cookware before using.** To test a dish for safe use, put it into the oven with 1 cup (250 mL) of water beside it. Cook at 100% cook power for one minute. **If the dish gets hot and water stays cool, do not use it.** Some dishes (melamine, some ceramic dinnerware, etc.) absorb microwave energy, becoming too hot to handle and slowing cooking times. Cooking in metal containers not designed for microwave use could damage the oven, as could containers with hidden metal (twist-ties, foil lining, staples, metallic glaze or trim).

---

## Operating tips

- **Never** lean on the door or allow a child to swing on it when the door is open.
- **Use hot pads.** Microwave energy does not heat containers, but heat from the food can make the container hot.  
**NOTE:** Heat from the broil element will cause container and oven parts to become hot. **Also, the Crisper Pan always becomes very hot when used.** Use oven mitts when touching containers, oven parts, and pan after broiling.
- **Do not** use newspaper or other printed paper in the oven.
- **Do not** dry flowers, fruit, herbs, wood, paper, gourds, or clothes in the oven.
- **Do not** start a microwave oven when it is empty. Product life may be shortened. If you practice programming the oven, **put** a container of water in the oven. It is normal for the oven door to look wavy after the oven has been running for a while.
- **Do not** try to melt paraffin wax in the oven. Paraffin wax will not melt in a microwave oven because it allows microwaves to pass through it.
- **When you use a browning dish,** the browning dish bottom must be at least  $\frac{3}{8}$  in (5 mm) above the turntable. Follow the directions supplied with the browning dish.
- **Never cook or reheat a whole egg inside the shell.** Steam buildup in whole eggs may cause them to burst and burn you, and possibly damage the oven. **Slice** hard-boiled eggs before heating. In rare cases,

poached eggs have been known to explode. **Cover** poached eggs and **allow** a standing time of one minute before cutting into them.

- **For best results, stir any liquid several times during heating or reheating.** Liquids heated in certain containers (especially containers shaped like cylinders) may become overheated. The liquid may splash out with a loud noise during or after heating or when adding ingredients (coffee granules, tea bags, etc.).
- **Microwaves** may not reach the center of a roast. The heat spreads to the center from the outer, cooked areas just as in regular oven cooking. This is one of the reasons for letting some foods (for example, roasts or baked potatoes) stand for a while after cooking, or for stirring some foods during the cooking time.
- **Do not deep fry** in the oven. Microwavable cookware is not suitable and it is difficult to maintain appropriate deep frying temperatures.
- **Do not overcook potatoes.** At the end of the recommended cooking time, potatoes should be slightly firm because they will continue cooking during standing time. **After microwaving,** let stand for 5 minutes to finish cooking.
- **Do not** operate the microwave oven unless the glass turntable is securely in place and can rotate freely. The turntable can rotate in either direction. **Make sure** the turntable is correct-side up in the oven. **Make sure** support base is all the way on the shaft in oven cavity floor. **Handle your turntable with care** when removing it from the oven to avoid possibly breaking it. If your turntable cracks or breaks, contact your appliance dealer for a replacement.

---

## Electrical connection

Your microwave is connected to a 110-volt side of the 240-volt circuit required for the lower oven. If the incoming voltage to the microwave is less than 110 volts, cooking times may be longer. Have a qualified electrician check your electrical system.



## Parts and features

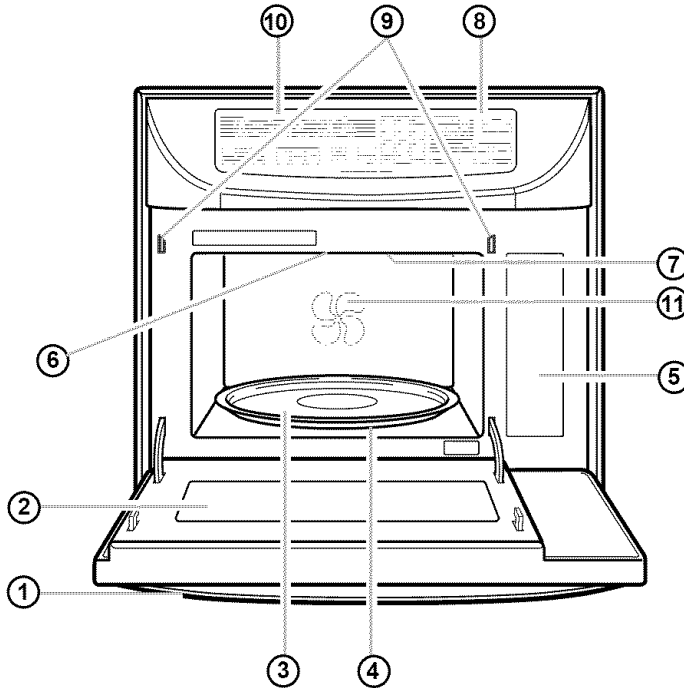

Your microwave oven is designed to make your cooking experience as enjoyable and productive as possible. To help get you up and running quickly, the following is a list of the oven's basic features:

- 1. Door Handle.**
- 2. Window with Metal Shield.** Shield prevents microwaves from escaping. It is designed as a screen to allow you to view food as it cooks.
- 3. Glass Turntable.** This turntable turns food as it cooks for more even cooking. It must be in the oven during operation for best cooking results.
- 4. Removable Turntable Support** (under turntable).
- 5. Cook Guide Label.**
- 6. Light.** Automatically turns on when door is opened or when oven is operating.
- 7. Quartz Broil Element** (hidden in ceiling). This element is used for the CRISP and BROIL functions. It is in a special computer-designed compartment that helps focus heat from the element onto the food. The quartz broil element is better than traditional broil elements because it gets hotter faster. And it is not in your way when you are cleaning the oven.
- 8. Microwave Oven Control Panel.** Touch pads on this panel to perform all functions.
- 9. Door Safety Lock System.** The oven will not operate unless the door is securely closed.
- 10. Lower Oven Control Panel.** See "Lower Oven Use and Care Guide" for more information.
- 11. Convection Element and Fan (not visible).** (Models KEMS378G, KEMS308G, KBMC147H and KBMC140H *only*.) This element and fan are used for the CONVECT function. See "Cooking with CONVECT in the microwave oven".



## Control panel features

(Models KEMS307G, KEMS377G, KEMS308G, KEMS378G)

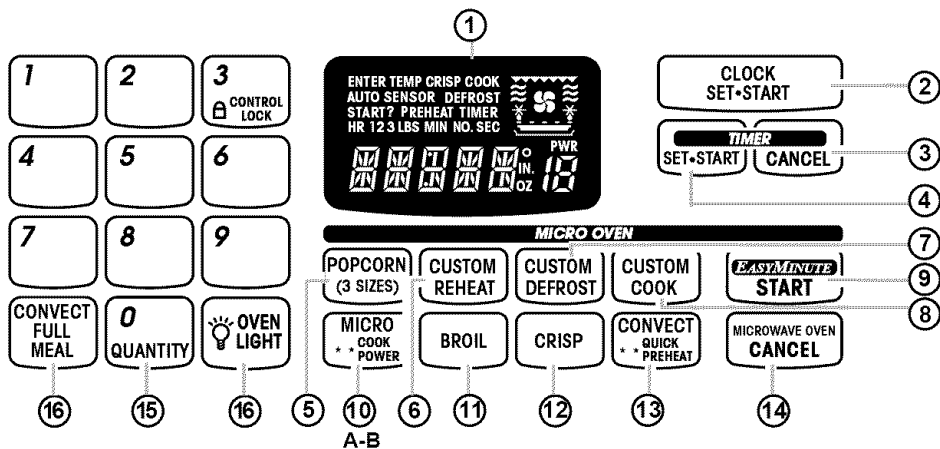

(Models KBMC147H, KBMC140H)

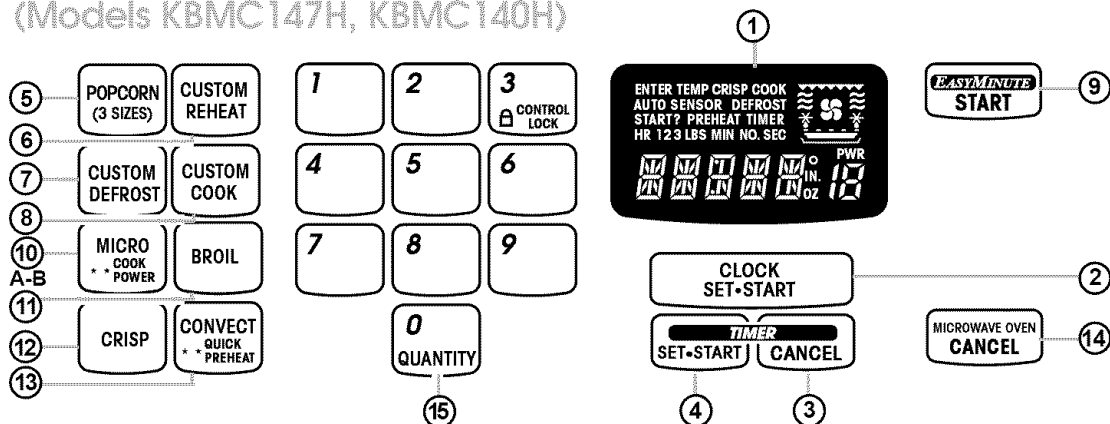

Your microwave oven control panel lets you select the desired cooking function quickly and easily. The following is a list of all the Command and Number pads located on the control panel.

You can also make cooking function choices by using Code pads. Code pads are Number pads used to select a cook power, food setting, or quantity.

1. **Display.** This display includes a clock and indicators to tell you the time of day, cooking time settings, cook powers, quantities, weights and cooking functions.
2. **CLOCK SET•START.** Touch this pad to enter the correct time of day.
3. **TIMER CANCEL.** Touch this pad to cancel the Minute Timer.

4. **TIMER SET•START.** Touch this pad followed by number pads to use as a kitchen timer
5. **POPCORN.** Touch this pad to pop popcorn in your microwave oven. The oven will automatically cook at a preset cook power and time.
6. **CUSTOM REHEAT.** Touch this pad to reheat food at a preset cook power and time.
7. **CUSTOM DEFROST.** Touch this pad to thaw frozen food by weight.
8. **CUSTOM COOK.** Touch this pad to cook foods at a preset cook power and time.
9. **EASY MINUTE/START.** Touch this pad to start a function you have set. You can also use it to cook for 1 minute at 100% cook power or to add an extra minute to your cooking cycle.

continued on next page 9



# Getting to Know Your Microwave Oven

- 10A. **MICRO.** Touch this pad before entering a cooking time when setting a second or third cycle in multi-cycle cooking.
- 10B. **COOK POWER.** Touch this pad, after the cook time has been set, followed by a Number pad to set the amount of microwave energy released to cook the food. The higher the number, the higher the power wattage and the faster the “cooking speed.”
- 11. **BROIL.** Touch this pad to broil with the broil element.
- 12. **CRISP.** Touch this pad to crisp pre-cooked pizza and other dough-based foods. Use it also for baking and for frying bacon and eggs, sausages, etc.
- 13. **CONVECT/QUICK PREHEAT.** (Models KEMS308G, KEMS378G, KBMC147H and KBMC140H only)  
Touch this pad to put microwave oven into the CONVECT cooking mode.
- 14. **MICROWAVE OVEN CANCEL.** Touch this pad to cancel a function. See next page for more information.
- 15. **Number Pads.** Touch Number pads to enter cooking times, cook powers, selection, quantities, or weights.
- 16. See “Lower Electric Convection Oven Use and Care Guide”.

## NOTES:

- If you touch one Command pad and then want to choose another Command pad in the same cycle, you must press CANCEL first.
- If you attempt to enter unacceptable instructions three tones will sound. Touch CANCEL and re-enter the instructions.

## Audible signals

Audible signals are available to guide you when setting and using your oven:

- **A programming tone will sound** each time you touch a pad.
- **Four tones** signal the end of a cooking cycle or the Minute Timer countdown.

## Choosing cooking function settings

The cooking functions discussed in the “Getting to Know Your Microwave Oven” and “Microwave Cooking” sections use Command pads to choose cooking function settings. Another way to choose cooking function settings is by using Code pads. Code pads are Number pads used to select a cook power, food settings, or quantities. Food setting charts found in the “Using CUSTOM REHEAT,” “Using CUSTOM DEFROST,” and “Using CUSTOM COOK” sections list only Code pads for food settings. The charts in “Using code pads” in the “Microwave Cooking” section list all the available Code pads.

## Interrupting cooking

You can stop the oven during a cycle by opening the door. The oven stops heating and the fan stops, but the light stays on. **To restart cooking for all cycles, close the door and**

TOUCH



If you do not want to continue cooking:

- **Close** the door and the light goes off
- AND**
- TOUCH





## Using the control lock

The control lock prevents unwanted use of the oven by disabling the control panel command pads.

### NOTES:

- **Control lock** is available only when both the lower oven and the microwave oven are not in use. It is also not available during the Self-Cleaning cycle or the Sabbath mode.
- **Control lock** does not disable the Timer or Clock.
- **Set** control lock when cleaning the control panel to prevent oven from accidentally turning on.

### To lock or deactivate the control panel:

Press and hold CONTROL LOCK (Number Pad 3) for 5 seconds. A single tone will sound and "CONTROL LOCK " will appear on the display.

### To unlock the control panel:

Press and hold CONTROL LOCK (Number Pad 3) for 5 seconds. A single tone will sound after 5 seconds and "CONTROL LOCK " will disappear from the display.

## Prompt for start

If "START?" is lit, this means that START has not been pressed. If you do not press START, the programmed function will automatically be canceled in 5 minutes.

---



## Utensils

Your microwave oven comes with two useful cooking utensils. Please review this chart to become familiar with their use.

**NOTE:** Use oven mitt when removing broiling grid and CRISPWARE™ Crisper Pan. Use Crisper Pan handle when removing Crisper Pan. Do not touch the top of the microwave oven when broiling.

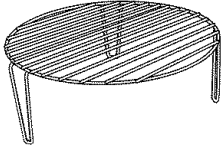
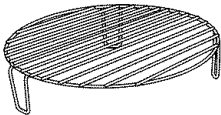

# Getting to Know Your Microwave Oven

UTENSIL			
<b>Broiling Grid</b> 	<b>Convection Grid (Short Legs)</b> 	<b>CRISPWARE™ Crisper Pan</b> 	<b>Crisper Pan Handle</b> 
HOW TO USE IT			
<p>Use for faster browning of small amounts of food. Place the broiling grid securely on the turntable. Using the broiling grid will put food close to the broil element.</p>	<p>Use for CONVECT cooking in the microwave oven. Place the grid securely on the turntable. Using the convection grid, position the food or baking dish in the best location for necessary (or required) air circulation during CONVECT cooking.</p>	<p>Use to give foods such as pizza and pies a nice crisp, brown bottom surface. Do not place any other utensils on the Crisper Pan since the pan quickly becomes very hot and can cause damage to the utensil. Always use the turntable as support for the Crisper Pan.</p> <p>The Crisper Pan is designed specifically for use with the patented Double Emission System in this oven. <b>Do not use Crisper Pan in any other microwave oven or in a thermal oven.</b></p> <p>The Crisper Pan is dishwasher safe.</p> <p><b>NOTE:</b> Only use wooden or plastic cooking utensils on the Crisper Pan to prevent scratches.</p>	

## Pan order chart

12¼" x 1" (31 cm x 2.54 cm) Crisper Pan  
P.N. 4375191

11½" x 1" (29 cm x 2.54 cm) Crisper Pan  
P.N. 4378131

11" x 1¾" (28 cm x 3.5 cm) Baking Pan  
P.N. 4378132

To order additional Crisper or Baking Pans, see the chart at left. Then call 1-800-422-1230 and follow the instructions and telephone prompts you hear.

OR

Use the CRISPWARE™ order card included with your Use and Care Guide.

## Setting the clock

When your microwave oven is first plugged in or after a power failure, the colon and time of day will flash for 5 minutes. "PF" will show on the lower oven Temperature Display until any pad is touched.

### NOTES:

- **You can only set** the clock when the lower oven and the microwave oven are not cooking food and when the Minute Timer is not counting down.
- **You can clear** the time of day from the Display by touching and holding CLOCK SET•START for 5 seconds. Touch CLOCK SET•START to see the time of day again.

### To set time:

#### 1. Choose the clock.

TOUCH



#### 2. Enter time of day.

Example for 5:30:

TOUCH





### 3. Complete entry.

TOUCH



OR



## Using the Minute Timer

**NOTE:** You can use other Command pads while the Minute Timer is counting down.

### 1. Choose the Minute Timer.

**NOTE:** The Timer does not start or stop the microwave oven. It works like a regular kitchen timer. It can be set in hours and minutes up to 99 hours and 59 minutes, or in minutes and seconds up to 99 minutes and 59 seconds.

TOUCH



once for minutes  
and seconds

OR

twice for hours  
and minutes

### 2. Enter time to be counted down.

Example for 10 minutes:

TOUCH

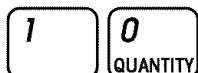

### 3. Start countdown.

TOUCH



(display shows time  
counting down)

When countdown ends, four tones will sound and the display will show “End”.

Four tones will sound and repeat every minute until you touch TIMER CANCEL. This will clear the Display.

### To cancel any time:

TOUCH

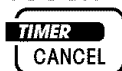

## Using EASY MINUTE

EASY MINUTE lets you cook food for 1 minute at 100% cook power or add an extra minute to your cooking cycle. You can also use it to extend cooking time in multiples of 1 minute, up to 99 minutes.

### NOTES:

- **To extend** cooking time in multiples of 1 minute, touch EASY MINUTE during cooking.
- **You can enter** EASY MINUTE only after closing the door.
- **You can use** EASY MINUTE with all timed cooking.
- **If the door** has been opened during cooking, you can restart cooking by closing the door and touching EASY MINUTE/START.

### 1. Put the food in oven and close the door.

### 2. Choose setting.

Example for one minute:

TOUCH



once

When cooking time ends, four tones will sound and the display will show “End”.

Four tones will repeat every minute until you open the oven door or touch CANCEL. This will clear the display.

# Microwave Cooking

This section gives you instructions for operating each microwave function. Please read these instructions carefully.

## Cooking at high cook power

### 1. Put food in oven and close the door.

### 2. Set cooking time.

Example for 1 minute, 30 seconds:

TOUCH



**NOTE:** During setup, if you want to change the cooking time you have entered, you must touch four digits. For example, to change 1 minute and 30 seconds to 1 minute and 45 seconds, touch Number pads 0, 1, 4, and 5.

### 3. Start oven.

TOUCH



#### NOTES:

- **If you want** to add more time during cooking use EASY MINUTE. See “Using EASY MINUTE” in the “Getting to Know Your Microwave Oven” section for more information.
- **If you want** to change the cooking time after cooking has started, touch MICRO and enter the new cooking time within 5 seconds.

When cooking time ends, four tones will sound, and the display will show “End”.

### 4. After cooking, open the door

OR

TOUCH



Four tones will repeat every minute until you open the oven door or touch CANCEL. This will clear the display.



## Cooking at different cook powers

For best results, some recipes call for different cook powers. The lower the cook power, the slower the cooking. Each Number pad also stands for a different percentage of cook power. Many microwave cookbook recipes tell you by number, percent, or name which cook power to use.

The following chart gives the percentage of cook power each Number pad stands for, and the cook power name usually used. It also tells you when to use each cook power. Follow recipe or food package instructions if available.

**NOTE:** Refer to a reliable cookbook for cooking times

COOK POWER	NAME	WHEN TO USE IT
10=100% of full power	High	<ul style="list-style-type: none"> <li>• Quick heating many convenience foods and foods with high water content, such as soups and beverages</li> <li>• Cooking small tender pieces of meat, ground meat, poultry pieces, fish fillets, and vegetables</li> </ul>
9=90% of full power		<ul style="list-style-type: none"> <li>• Heating cream soups</li> </ul>
8=80% of full power		<ul style="list-style-type: none"> <li>• Heating rice, pasta, or casseroles</li> </ul>
7=70% of full power	Medium-High	<ul style="list-style-type: none"> <li>• Cooking sensitive foods such as cheese and egg dishes, pudding, and custards</li> <li>• Cooking non-stirrable casseroles, such as lasagna</li> </ul>
6=60% of full power		<ul style="list-style-type: none"> <li>• Cooking sensitive foods such as cheese and egg dishes, pudding, and custards</li> <li>• Cooking non-stirrable casseroles, such as lasagna</li> </ul>
5=50% of full power	Medium	<ul style="list-style-type: none"> <li>• Cooking ham, whole poultry, and pot roasts</li> <li>• Melting chocolate</li> </ul>
4=40% of full power		<ul style="list-style-type: none"> <li>• Simmering stews</li> <li>• Heating pastries</li> </ul>
3=30% of full power	Medium-Low, Defrost	<ul style="list-style-type: none"> <li>• Defrosting foods, such as bread, fish, meats, poultry, and precooked foods</li> </ul>
2=20% of full power		<ul style="list-style-type: none"> <li>• Softening butter, cheese, and ice cream</li> </ul>
1=10% of full power	Low	<ul style="list-style-type: none"> <li>• Keeping food warm</li> <li>• Taking chill out of fruit</li> </ul>

**NOTE:** For information on which cook powers and cooking times you need for specific foods, see the “Microwave cooking chart” in the “Cooking Guide” section.

## Cooking at different cook powers (cont.)

1. Put food in oven and close the door.

2. Set cooking time.

Example for 10 minutes, 30 seconds:

TOUCH



3. Set cook power.

Example for 50% cook power:

TOUCH



then

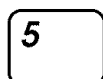

**NOTE:** During setup, if you want to change the cooking time after setting the cook power, wait for TIME to reappear on the display, then enter the new cooking time.

4. Start oven.

TOUCH



(display counts down time)

**NOTES:**

- If you want to add more time during cooking use EASY MINUTE. See "Using EASY MINUTE" in the "Getting to Know Your Microwave Oven" section for more information.
- If you want to change cooking time after cooking has started, touch MICRO and enter the new cooking time within 5 seconds.

When cooking time ends, four tones will sound and the display will show "End".

5. After cooking, open the door

OR

TOUCH



Four tones will repeat every minute until you open the oven door or touch CANCEL. This will clear the display.

## Cooking in stages

For best results, some recipes call for one cook power for a certain length of time, and another cook power for another length of time. Your oven can be set to change from one to another automatically.

1. Put food in oven and close the door.

2. Set cooking time for first cycle.

Example for 7 minutes, 30 seconds:

TOUCH

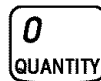

3. Set cook power for first cycle (optional).

If you want to cook at full (100%) cook power, go to Step 5.

Example for 50% cook power:

TOUCH



then



**NOTE:** During setup, if you want to change the cooking time after setting the cook power, wait for TIME to reappear on the display, then enter the new cooking time.



## 4. When display says “TIME,” touch MICRO to set second cycle.

TOUCH



## 5. Set cooking time for second cycle.

Example for 3 minutes, 25 seconds:

TOUCH

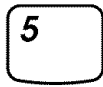
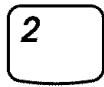

## 6. Set cook power for second cycle (optional).

If you want to cook at full (100%) cook power, go to Step 8.

Example for 60% cook power:

TOUCH

then



## 7. Repeat Steps 4 to 6 above for third cycle (optional).

## 8. Start oven.

TOUCH



(display counts down cooking time in each cycle, starting with first cycle)

One short tone will sound between cycles.

### NOTES:

- If you want to add more time during cooking use EASY MINUTE. See “Using EASY MINUTE” in the “Getting to Know Your Microwave Oven” section for more information.
- During any Micro cooking stage, you can change the cooking time after touching START. Simply touch MICRO and enter the new cooking time within 5 seconds.

When cooking time ends, four tones will sound, and the display will show “End”.

## 9. After cooking, open the door

OR

TOUCH

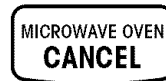

Four tones will repeat every minute until you open the oven door or touch CANCEL. This will clear the display.

## Using CUSTOM REHEAT

Your microwave oven automatically reheats food. You do not have to enter times or temperatures.

**NOTE:** If you want to manually reheat using a cook time and cook power see “Reheating chart” in the “Cooking Guide” section.

### Summary of steps for setting CUSTOM REHEAT

1. Touch CUSTOM REHEAT.
2. Touch CUSTOM REHEAT again to scan and select reheat food settings.
3. Touch QUANTITY to scan and select available quantity settings.

continued on next page



## Custom reheat chart

CODE	FOOD SETTING	QUANTITY
1	Dinner Plate	1 to 2 servings
2	Bread	1 to 6 slices
3	Meats	1 to 6 servings
4	Cheese Dip	1 to 3 cups (250-750 mL)
5	Soups	1 to 4 cups (250 mL-1 L)
6	Sauce	1 to 3 cups (250-750 mL)
7	Pizza	1 to 2 servings
8	Beverage	<b>SERVING TEMPERATURE</b>
	• Coffee	Warm
	• Tea	Hot
	• Hot Chocolate	Very Hot

1. Put food in oven and close door.

2. Touch **CUSTOM REHEAT**.



3. Choose food setting.

Keep touching CUSTOM REHEAT until the food that you are cooking appears on the display.

Example for Dinner Plate (Setting 1):

TOUCH



once

## NOTES:

- To choose the desired food code, see the Cooking Guide Label on the front frame of the oven or the "Custom reheat chart" earlier in this section.
- You can disable or enable the Quantity pad prompt. See "Using help prompts" in the "Cooking Guide" section for more information.

4. Enter food quantity.

Example for 2 servings:

TOUCH



twice

Touch START or wait 5 seconds for oven to start automatically.

TOUCH



The remaining time will count down. If you have chosen any of settings 4, 5, or 6, four tones will sound in the middle of the cycle and the display will show "STIR" for 5 seconds. You can then stir food if desired. To restart the cycle you must close the door and touch START.

When reheating time ends, four tones will sound, and the display will show "End".

5. After reheating, open the door

OR

TOUCH



Four tones will repeat every minute until you open the oven door or touch CANCEL. This will clear the display.



## Heating a beverage (Setting 8)

1. Place beverage in oven and close door.

2. Touch CUSTOM REHEAT.



3. Choose beverage setting.

Keep touching CUSTOM REHEAT until "BEVRG" appears on the display.

TOUCH



eight times

4. Enter type of beverage.

Touch CUSTOM REHEAT until the type of beverage you want appears on the display.

TOUCH



three times

Example for Hot Chocolate:

BEVERAGE	TOUCH CUSTOM REHEAT
Coffee	once
Tea	twice
Hot Chocolate	three times

5. Enter serving temperature.

Keep touching CUSTOM REHEAT until the temperature you want shows on the display.

Example for Hot:

TOUCH



twice

Serving temperatures:

SERVING TEMPERATURE	TOUCH CUSTOM REHEAT
Warm	once
Hot	twice
Very Hot	three times

Touch START or wait 5 seconds for oven to start automatically.

TOUCH



The heating time will count down.

**NOTE:** Liquid may splash out during or after heating while stirring or adding ingredients such as coffee granules, tea bags, etc. (See "Operating tips" in the "Getting to Know Your Microwave Oven" section for more information.)

When heating time ends, four tones will sound, and the display will show "End".

6. After heating, open the door

OR

TOUCH



Four tones will repeat every minute until you open the oven door or touch CANCEL. This will clear the display.



## Using CUSTOM DEFROST

Your microwave oven uses a preset defrost time and power according to the food setting and the food quantity that you choose.

**NOTE:** Standing time is included in the defrosting time selected by your microwave oven. This may make defrosting times seem longer than in other microwave ovens. (See “Defrosting tips” later in this section for more information.)

### Custom defrost chart

CODE	FOOD SETTING	WEIGHT OR QUANTITY
1	Meats	0.10 lb (1 oz [28 g]) to 6.60 lbs (6 lbs, 8 oz [3 k])
2	Chicken/Poultry	0.10 lb (1 oz [28 g]) to 6.60 lbs (6 lbs, 8 oz [3 k])
3	Fish/Seafood	0.10 lb (1 oz [28 g]) to 4.40 lbs (4 lbs, 6 oz [1.34 k])
4	Bagel	1 to 6
5	Fruit Juice	6, 12, or 16 oz (170, 340, or 454 g)
6	Roll/Muffin	1 to 6

**NOTE:** Bagel quantity settings 1 and 2 may appear to have longer defrost times than necessary. However, longer times use less cook power.

**1. Put food in oven and close door.**

**2. Touch CUSTOM DEFROST.**



## Summary of steps for setting CUSTOM DEFROST

1. Touch CUSTOM DEFROST.
2. Touch CUSTOM DEFROST again to scan and select food settings.
3. Enter weight or touch QUANTITY to select quantity.

**3. Choose food setting.**

Keep touching CUSTOM DEFROST until the food that you are cooking appears on the display.

Example for Meats (Setting 1):

TOUCH



once

**NOTE:** To choose the desired food setting, see the Cooking Guide Label on the front frame of the oven, the “Custom defrost chart” earlier in this section, or scan through the settings by pressing the Quantity pad (once for each setting).



## 4. Enter food weight.

Example for 1.25 lbs (.57 k):

TOUCH



### NOTES:

- **Use** Number pads for settings 1 to 3. Use the Quantity pad for settings 4 to 6.
- **If you enter** a weight greater than the maximum weight listed in the “Custom defrost chart” earlier in this section, “RETRY” shows on the display.
- **See** the “Weight conversion chart” later in this section for help in converting food weight to decimals.
- **See** the “Custom defrost chart” earlier in this section for weight ranges available for each food category.
- **Each time** you touch the Quantity pad to select a cooking weight for settings 1-3, the display increases by a quarter pound. For settings 4 to 6 the display changes to the next higher quantity/weight.

TOUCH



Touch START or wait 5 seconds for oven to start automatically. The remaining time will count down.

If you have chosen any of settings 1, 2, or 3, four tones will sound in the middle of the cycle and the display will show “TURN” for 5 seconds. You can then turn food if desired. To restart the cycle you must close the door and touch START.

When defrosting time ends, four tones will sound, and the display will show “End”.

## 5. After defrosting, open the door

OR

TOUCH

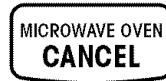

Four tones will repeat every minute until you open the oven door or touch CANCEL. This will clear the display.

continued on next page



## Weight conversion chart

You are probably used to food weights as being in pounds and ounces that are fractions of a pound (for example, 4 ounces equals  $\frac{1}{4}$  pound). However, in order to enter food weight in CUSTOM DEFROST, you must specify pounds and tenths of a pound. If the weight on the food package is in fractions of a pound, you can use the following chart to convert the weight to decimals.

<u>EQUIVALENT WEIGHT</u>		DECIMAL WEIGHT	POUND WEIGHT
OUNCES	METRIC (g)		
1.6	45.4	.10	
3.2	90.7	.20	
4.0	113.4	.25	One-Quarter Pound
4.8	136.1	.30	
6.4	181.4	.40	
8.0	226.8	.50	One-Half Pound
9.6	272.2	.60	
11.2	317.5	.70	
12.0	340.2	.75	Three-Quarters Pound
12.8	362.9	.80	
14.4	408.2	.90	
16.0	453.6	1.00	One Pound

## Defrosting tips

- **When** using CUSTOM DEFROST, the weight to be entered is the net weight in pounds, and tenths of pounds (the weight of the food minus the container).
- **CUSTOM DEFROST** gives best results when food to be thawed is a minimum of 0°F (-18°C) or colder.
- **If the food is kept outside** the freezer for more than 20 minutes, and for defrosting ready-made food, defrost by time and power and let stand after defrosting.
- **The shape of the package** affects how quickly food will defrost. Shallow packages will defrost more quickly than a deep block.
- **As food begins to defrost**, separate the pieces. Separated pieces defrost more evenly.
- **Use small pieces** of aluminum foil to shield parts of food such as chicken wings, leg tips, fish tails, or areas that start to get warm. Make sure the foil does not touch the sides, top, or bottom of the oven. The foil can damage the oven lining.
- **For better results, a preset standing time** is included in the defrosting time. This may make the defrosting time seem longer than expected.



## Popping popcorn

POPCORN lets you pop commercially packaged microwave popcorn by touching just one pad. Pop only one package at a time. Try several brands to decide which gives best popping results. For best results, use fresh bags of popcorn. Cooking performance may vary with brand and fat content. If you are using a microwave popcorn popper, follow manufacturer's instructions.

**NOTE:** If you want to add more time during or after popping use EASY MINUTE.

**IMPORTANT:** Never leave microwave unattended when adding more popping time than recommended by the automatic cycle.

1. Place bag in center of turntable and close door.

### 2. Touch POPCORN.

**POPCORN**  
(3 SIZES)

once

The microwave oven will automatically pop a 3.5 oz (99 g) bag of popcorn when you touch POPCORN. If you want to pop a different size bag of popcorn, follow the chart below:

SIZE OF BAG	TOUCH POPCORN PAD
3.5 oz (99 g)	once
3.0 oz (85 g)	twice
1.75 oz (50 g)	three times

### 3. Start oven.

TOUCH



Touch START or wait 5 seconds for the oven to start automatically. The popping time will count down.

When popping time ends, four tones will sound, and the display will show "End".

### 4. After popping popcorn, open the door

OR

TOUCH



Four tones will repeat every minute until you open the oven door or touch CANCEL. This will clear the display.

## Using CUSTOM COOK

Cooking with CUSTOM COOK lets you cook food without needing to set times and cook powers. CUSTOM COOK has preset times and cook powers (see the "Custom cook chart").

**NOTE:** When cooking with cook time and cook power, see the "Microwave cooking chart" in the "Cooking Guide" section.

### Summary of steps for setting CUSTOM COOK

1. Touch CUSTOM COOK.
2. Touch CUSTOM COOK again to scan and select food settings.
3. Touch QUANTITY to scan and select quantity settings.



## Custom cook chart

CODE	FOOD	QUANTITY	PREPARATION
1	<b>Frozen Entree</b>	9 oz (240 g), 11 oz (311 g), 16 oz (425 g)	Follow package directions.
2	<b>Casserole</b>	2 cups (500 mL), 4 cups (1 L), 6 cups (1.5 L), 8 cups (2 L)	To reheat, flatten on plate or place in bowl. Cover with lid or vented plastic wrap. Stir before serving.
3	<b>Frozen Vegetables</b>	1 to 4 cups (250 mL- 1L)	Place in a microwave safe container. Cover with lid or plastic wrap. After cooking remove from oven, stir, cover, and let stand 3 minutes before serving.  <b>NOTE:</b> When cooking a 10 oz (284 g) package of frozen vegetables (this equals about 1½ cups [375 mL]), touch Quantity pad once for 1 cup (250 mL) of “tender crisp” vegetables (you cannot enter ½ cup [125 mL] amounts) or touch Quantity pad twice for 2 cups (500 mL) of vegetables more fully cooked.
4	<b>Bacon</b>	2, 3, 4, or 6 strips	Place on microwave safe container. Cover with paper towel. After cooking remove from oven carefully.
5	<b>Fresh Vegetables</b>	1 to 4 cups (250 mL-1L)	Place in a microwave-safe container. For beans, carrots, corn, and peas, add 1 tablespoon (15 mL) water per cup. For broccoli, brussels sprouts, cabbage, and cauliflower, cook immediately after washing with no additional water. If you like tender-crisp vegetables, set the Custom Cook quantity for half the amount of vegetables you are actually cooking. For example, when cooking 2 cups (500 mL) of vegetables, set QUANTITY for 1 cup (250 mL). Cover with lid or plastic wrap. After cooking, remove from oven, stir, cover, and let stand 3 to 5 minutes before serving.
6	<b>Frozen Burrito</b>	1, 2, 3, or 4	Follow package directions.
7	<b>Hot Dogs</b>	1, 2, 4, or 6	Pierce hot dogs with a fork and place on a microwave safe container. Cover hot dogs with a paper towel.
8	<b>Baked Potatoes</b>	1 to 6	Before baking, remember to pierce potatoes with a fork several times. After cooking, wrap in foil and let potato stand 5 minutes.



## 1. Put food in oven and close door.

Touch START or wait 5 seconds for oven to start automatically.

The cooking time will count down.

## 2. Touch CUSTOM COOK.

CUSTOM  
COOK

When cooking time ends, four tones will sound, and the display will show "End".

## 3. Choose food setting.

Keep touching CUSTOM COOK until the food that you are cooking appears on the display.

Example for Casseroles (Code 2):

TOUCH

CUSTOM  
COOK

twice

## 5. After cooking, open the door OR

TOUCH

MICROWAVE OVEN  
CANCEL

Four tones will repeat every minute until you open the oven door or touch CANCEL. This will clear the display.

### NOTES:

- To choose the desired food setting, see the Cook Guide Label on the front frame of the oven or the "Custom cook chart" earlier in this section.
- You can disable or enable the Quantity pad prompt. See "Using help prompts" in the "Cooking Guide" section for more information.

## Keeping food warm

You can safely keep hot, cooked food warm in your microwave oven for up to 99 minutes.

## 4. Enter food size or weight.

Example for 4 cups (1 L):

TOUCH

0  
QUANTITY

twice

TOUCH

EASYMINUTE  
START

### 1. Put hot, cooked food in oven and close the door.

### 2. Set keep-warm time (up to 99 minutes).

### 3. Set cook power at 10% (see pages 14).

### 4. Start oven.

To program keep-warm at the end of a microwave cooking cycle, follow the instructions in the "Cooking in stages" section using 10% power up to 99 minutes as the last cycle.

### NOTES:

- **Food cooked covered** should be covered when kept warm
- **Pastry items** (pies, turnovers, etc.) should be uncovered when kept warm.
- **Complete meals** should be covered when kept warm on a dinner plate.

# Cooking with CRISP and BROIL

This section gives you step-by-step instructions for operating the Crisp and Broil functions.

## To get the best cooking results

- **The CRISPWARE™ Crisper Pan** is specially designed for crisping and browning food. It can be preheated for 2 to 3 minutes before use.
- **Brush Crisper Pan** with ½ tsp (3 mL) of oil or spray with nonstick cooking spray before heating. This will make it easier to remove food from the pan and clean the pan after use.

- **Use the broiling grid** with or without the Crisper pan. When cooking with the broil element, the Crisper pan will catch drippings from the food.
- **Use the broiling grid** to place food closer to the broil element for faster cooking. See “Utensils” in the “Getting to Know Your Microwave Oven” section for more information.
- **If you want** to add more time during cooking use EASY MINUTE.

## Using CRISP

Use CRISP to cook and brown food in the Crisper Pan. For example, use CRISP for sauteing meats and vegetables, for pan frying bacon and eggs, and for crisping and browning pizza and cheese sandwiches.

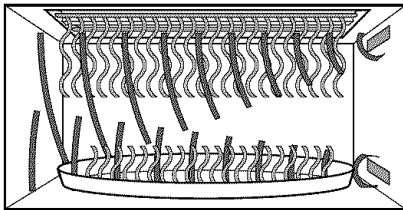

When using CRISP, microwaves heat the Crisper Pan to brown and crisp the bottom of food while the broil element cooks and browns food from the top.

1. **Place food on Crisper Pan, put pan on turntable, and close door.**

## 2. Choose CRISP.

TOUCH

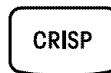

## 3. Set crisping time.

Example for 10 minutes:

TOUCH



**NOTE:** If you enter a crisping time greater than 90 minutes, “RETRY” shows on the display.

## 4. Start oven.

TOUCH





## NOTES:

- **You can increase** crisping time after touching START by pressing EASY MINUTE.
- **You can disable or enable** the USE PAN prompt. See “Using help prompts” in the “Cooking Guide” section for more information.

After 4 seconds, the cooking time will count down.

When cooking time ends, four tones will sound and the display will show “End.”

## 5. After cooking, open the door

OR

TOUCH



Four tones will repeat every minute until you open the oven door or touch CANCEL. This will clear the display.

## Using BROIL

Broil lets you cook and brown small amounts of food (from 1 to 4 pieces). The broil element is located in the microwave oven ceiling near the door.

### For best results when broiling:

- **Remove** turntable coupling located in the center of the oven bottom under the glass turntable. See the “Caring for Your Microwave Oven” section for more information.
- **Replace** the glass turntable.
- **Preheat** the broil element for 2 to 3 minutes.
- **After preheating**, place all food on one half of the broiling grid only.
- **Place** grid securely on turntable with food positioned in the front area close to the door and directly under the broil element.
- **For even browning**, turn food over halfway through cooking.
- **Do not leave** the oven door open for long periods of time when using the broil element. This could affect cooking performance.

## 1. Put food in oven and close door.

## 2. Touch BROIL.



## 3. Set broiling time.

TOUCH

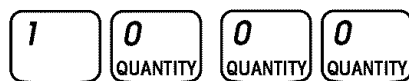

**NOTE:** If you try to enter a broiling time greater than 90 minutes, “RETRY” shows on the display.

## 4. Start oven.

TOUCH



## NOTES:

- **You can increase** broiling time after touching START by pressing EASY MINUTE.
- **You can disable or enable** the USE GRID prompt. See “Using help prompts” in the “Cooking Guide” section for more information.

When cooking time ends, four tones will sound, and the display will show “end.”

## 5. After cooking, open the door

OR

TOUCH

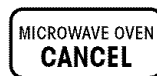

Four tones will repeat every minute until you open the oven door or touch CANCEL. This will clear the display.

# Cooking with CONVECT

(Models KEMS308G, KEMS378G, KBMC147H, and KBMC140H only)

This section gives you step-by-step instructions for operating the CONVECT function in the microwave oven.

## NOTE:

- Use the short convection grid with bakeware or place food directly on grid. The turntable will catch drippings from the food.

## Using CONVECT

TOUCH



Touch this pad to cook small amounts of food on a single rack using the CONVECT feature in the microwave oven. For even heating, the fan at the rear of the microwave oven circulates the heated air from the element. **Do not cover** the grid with aluminum foil. **Always use** the convection grid when cooking with CONVECT. The grid positions the food in the best location for air circulation around it during cooking. **Place the grid** in the microwave oven before preheating.

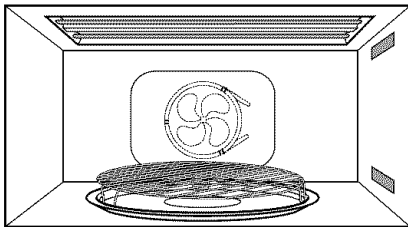

**We recommend preheating** the oven before placing food inside for cooking. When the microwave oven is preheated, **place cookware** containing food on the convection grid or place food directly on the grid. **Prevent heat loss** by opening the door only when necessary and closing it quickly during CONVECT cooking.

**NOTE:** You may choose to QUICK PREHEAT or not to preheat.

## CONVECT cooking with QUICK PREHEAT

1. Place convection grid in oven and close the door.

2. Set QUICK PREHEAT.

TOUCH



twice

## NOTES:

- You can change the cooking temperature setting as desired from 170°F (75°C) minimum to 450°F (232°C) maximum by touching the correct number keys now.
- Cooking times using CONVECT may be slightly longer than suggested in the cookbook recipes included with your lower oven.

THEN

TOUCH



3. When display says “TIME,” set cooking time by touching Number keys.

Example for 1 hr, 25 min:

TOUCH



## NOTES:

- Cooking time is 4 hours maximum. If you enter a cooking time longer than 4 hours, the display will reset itself to 4:00.



- When preheat reaches 170°F (75°C), the display will show temperature in 5°F (-15°C) increments until oven reaches set cooking temperature.

When preheat time ends, one tone will sound, and the display will show cooking time.

4. Place food or bakeware on short convection grid positioned on turntable. Close the door.

5. Start oven

TOUCH



(display counts down cooking time)

NOTE:

- Each time you open and close the microwave door, you must touch EASY MINUTE/START again.

When cooking time ends, four tones will sound, and the display will show “end.”

6. After cooking, open the door

OR

TOUCH



Four tones will repeat every minute until you open the oven door or touch CANCEL. This will clear the display.

## CONVECT cooking without preheat

1. Put food in bakeware and place bakeware on short convection grid or put food directly on grid positioned on oven turntable. Close the door.

2. Choose CONVECT.

TOUCH



once

NOTE:

- You can change the cooking temperature setting as desired from 170°F (75°C) minimum to to 450°F (232°C) maximum by touching the correct number keys now.

3. When display says “TIME,” set cooking time by touching Number keys.

Example for 1 hr, 25 min:

TOUCH



NOTES:

- Cooking time is 4 hours maximum. If you enter a cooking time longer than 4 hours, the display will reset itself to 4:00.
- When preheat reaches 170°F (75°C), the display will show temperature in 5°F (-15°C) increments until oven reaches set cooking temperature.

4. Start oven.

TOUCH



(display counts down cooking time)

NOTE:

- Each time you open and close the microwave door, you must touch EASY MINUTE/START again.

When cooking time ends, four tones will sound, and the display will show “end.”

5. After cooking, open the door

OR

TOUCH

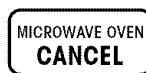

Four tones will repeat every minute until you open the oven door or touch CANCEL. This will clear the display.

# Cooking Guide

## Using code pads

You can use Number pads as shortcuts when cooking with your microwave oven. For example, to reheat 1 cup (250 mL) of cheese dip:

1. Press the Reheat pad.
2. Choose category 4 by pressing Number pad 4.
3. Choose one cup by pressing the Number pad 1.

All food categories and many food quantities have matching Number pads. The charts below show how you may use the Number pads to choose cook powers, food categories, and food quantities.

## COOK POWER

% OF FULL COOK POWER	TOUCH
90%	9
80%	8
70%	7
60%	6
50%	5
40%	4
30%	3
20%	2
10%	1
0%	0

## CUSTOM REHEAT

CATEGORY	TOUCH	QUANTITY	TOUCH
Dinner Plate	1	1 to 2 servings	1 or 2
Bread	2	1 to 6 slices	1, 2, 3, 4, 5, or 6
Meats	3	1 to 6 servings	1, 2, 3, 4, 5, or 6
Cheese Dip	4	1 to 3 cups (250-750 mL)	1, 2, or 3
Soups	5	1 to 4 cups (250-1000 mL)	1, 2, 3, or 4
Sauce	6	1 to 3 cups (250-750 mL)	1, 2, or 3
Pizza	7	1 to 2 servings	1 or 2
Beverage	8	<b>Beverage</b>	<b>Serving Temperature</b>
		Coffee 1	Warm 1
		Tea 2	Hot 2
		Hot Chocolate 3	Very Hot 3

## CUSTOM DEFROST

CATEGORY	TOUCH	QUANTITY	TOUCH
Meats	1	0.10 (1 oz.) to 6.60 lbs (6 lbs, 8 oz)	Enter actual weight or press the Quantity Pad to increase displayed weight by ¼ pounds (113 g).
Chicken/Poultry	2	0.10 (1 oz.) to 6.60 lbs (6 lbs, 8 oz)	
Fish/Seafood	3	0.10 (1 oz.) to 4.40 lbs (4 lbs, 6 oz)	
Bagel	4	1 to 6	1, 2, 3, 4, 5, or 6
Fruit Juice		6 oz (170 g), 12 oz (340 g), 16 oz (455 g)	Quantity Pad
Roll/Muffin	6	1 to 6	1, 2, 3, 4, 5, or 6



## CUSTOM COOK

FOOD SETTING	TOUCH	QUANTITY	TOUCH
Frozen Entree	1	9 oz (240 g), 11 oz (311 g), 16 oz (425 g)	Quantity Pad
Casserole	2	2 cups (.5 L), 4 cups (1 L), 6 cups (1.5 L), 8 cups (2 L)	Quantity Pad
Frozen Vegetables	3	1 to 4 cups (250 mL to 1 L)	1, 2, 3, or 4
Bacon	4	2, 3, 4, or 6 strips	Quantity Pad
Fresh Vegetables	5	1 to 4 cups (250 mL to 1 L)	1, 2, 3, or 4
Frozen Burrito	6	1 to 4	1, 2, 3, or 4
Hot Dogs	7	1, 2, 4, 6	Quantity Pad
Baked Potato	8	1 to 6	1, 2, 3, 4, 5, or 6

## POPCORN

SIZE OF BAG	TOUCH
3.50 oz (99 g)	1
3.00 oz (85 g)	2
1.75 oz (50 g)	3

## Using help prompts

When using the BROIL or CRISP mode on the microwave oven, you can disable or enable help prompts by pressing and holding Number pad 2 for 5 seconds. The display will tell you when the help prompt changes to on or off.



## Microwave reheating chart

Times are approximate and may need to be adjusted to individual tastes.

ITEM	STARTING TEMP	TIME/POWER	PROCEDURE
<b>Meat</b> (Chicken pieces, chops, hamburgers, meat loaf slices) 1 serving 2 servings	Refrigerated Refrigerated	1 to 2 min at 70% 2½ to 4½ min at 70%	Cover loosely. (Do not cover when broiling.)
<b>Meat Slices</b> (Beef, ham, pork, turkey) 1 or more servings	Room temp Refrigerated	45 sec to 1 min per serving at 50% 1 to 3 min per serving at 50%	Cover with gravy or wax paper. Check after 30 sec per serving.
<b>Stirrable Casseroles and Main Dishes</b> 1 serving 2 servings 4-6 servings	Refrigerated Refrigerated Refrigerated	2 to 4 min at 100% 4 to 6 min at 100% 6 to 8 min at 100%	Cover. Stir after half the time.
<b>Nonstirrable Casseroles and Main Dishes</b> 1 serving 2 servings 4-6 servings	Refrigerated Refrigerated Refrigerated	5 to 8 min at 50% 9 to 12 min at 50% 13 to 16 min at 50%	Cover with wax paper.
<b>Soup, Cream</b> 1 cup (250 mL) 1 can (10 oz [284 mL])	Refrigerated Room temp	3 to 4½ min at 50% 5 to 7 min at 50%	Cover. Stir after half the time.
<b>Soup, Clear</b> 1 cup (250 mL) 1 can (10 oz [284 mL])	Refrigerated Room temp	2½ to 3½ min at 100% 4 to 5½ min at 100%	Cover. Stir after half the time.
<b>Pizza (Medium Slice)</b> 1 slice 1 slice 2 slices 2 slices	Room temp Refrigerated Room temp Refrigerated	15 to 25 sec at 100% 30 to 40 sec at 100% 30 to 40 sec at 100% 45 to 55 sec at 100%	
<b>Vegetables</b> 1 serving 2 servings	Refrigerated Refrigerated	¾ to 1½ min at 100% 1½ to 2½ min at 100%	Cover. Stir after half the time.
<b>Baked Potato</b> 1 2	Refrigerated Refrigerated	1 to 2 min at 50% 2 to 3 min at 50%	Cut potato lengthwise and then several times crosswise. Cover with wax paper.
<b>Breads</b> (Dinner or breakfast roll) 1 roll 2 rolls 4 rolls	Room temp Room temp Room temp	8 to 12 sec at 50% 11 to 15 sec at 100% 18 to 22 sec at 100%	Wrap single roll, bagel, or muffin in paper towel. To re-heat several, line plate with paper towel. Cover with another paper towel.
<b>Pie</b> Whole 1 slice	Refrigerated Refrigerated	5 to 7 min at 70% 30 sec at 100%	



## Microwave cooking chart

Times are approximate and may need to be adjusted to individual tastes.

FOOD	COOK POWER	TIME
<b>MEATS, POULTRY, FISH, SEAFOOD</b>		
<b>Bacon</b> (per slice)	100%	45 sec to 1 min 15 sec per slice
<b>Ground Beef for Casseroles</b> (1 lb [.45 kg])	100%	4 to 6 min
<b>Ground Beef Patties</b> (2)	100%	1st side 2 min, 2nd side 1½ to 2½ min
<b>Ground Beef Patties</b> (4)	100%	1st side 2½ min, 2nd side 2 to 3 min
<b>Meat Loaf</b> (1½ lbs [.7 kg])	70%	13 to 19 min
<b>Chicken Pieces</b> Internal temperature should be 185°F (85°C) after standing.	100%	6 to 9 min/lb (454 g)
<b>Turkey Breast</b> Internal temperature should be 185°F (85°C) after standing.	100% 70%	5 min, <u>then</u> 8 to 12 min/lb (454 g)
<b>Fish Fillets</b> (1 lb [.45 kg])	100%	5 to 6 min
<b>Scallops and Shrimp</b> (1 lb [.45 kg])	100%	3½ to 5½ min
<b>VEGETABLES</b>		
<b>Beans, Green or Yellow</b> (1 lb [.45 kg])	100%	6 to 12 min
<b>Broccoli</b> (1 lb [.45 kg])	100%	6 to 10 min
<b>Carrots</b> (1 lb [.45 kg])	100%	8 to 12 min
<b>Cauliflower</b> (medium head)	100%	6 to 9 min
<b>Corn on the Cob</b> (2)	100%	4 to 9 min
(4)	100%	6 to 16 min
<b>Potatoes, Baked</b> (4 medium)	100%	13 to 19 min
<b>Squash, Summer</b> (1 lb [.45 kg])	100%	3 to 8 min
<b>OTHER</b>		
<b>Applesauce</b> (4 servings)	100%	7 to 10 min
<b>Baked Apples</b> (4)	100%	4 to 6 min
<b>Chocolate</b> (melt 1 square)	50%	1 to 2 min
<b>Eggs, Scrambled</b> (2)	100%	1 min 15 sec to 1 min 45 sec
(4)	100%	2 to 3 min
<b>Hot Cereals</b> (1 servings)	100%	1½ to 5 min
(4 servings)	100%	4½ to 7 min
<b>Nachos</b> (large plate)	50%	1½ to 2½ min
<b>Water for Beverage</b> (1 cup [250 mL])	100%	2½ to 4 min
(2 cups [500 mL])	100%	4½ to 6 min



## Cooking tips

### Amount of food

- **If you increase or decrease** the amount of food you prepare, the time it takes to cook that food will also change. For example, if you double a recipe, add a little more than half the original cooking time. Check for doneness and, if necessary, add more time in small increments.

### Starting temperature of food

- **The lower the temperature** of the food being put into the microwave oven, the longer it takes to cook. Food at room temperature will be reheated more quickly than food at refrigerated temperature.

### Composition of food

- **Food with a lot of fat and sugar** will be heated faster than food containing a lot of water. Fat and sugar will also reach a higher temperature than water in the cooking process.
- **The more dense the food**, the longer it takes to heat. "Very dense" food like meat takes longer to reheat than lighter, more porous food like sponge cakes.

### Size and shape

- **Smaller pieces of food** will cook faster than larger pieces and same-shaped pieces of food cook more evenly than irregularly shaped foods.
- **With unevenly shaped foods**, the thinner parts will cook faster than the thicker areas. **Place** the thinner parts of chicken wings and legs in the center of the dish.

### Stirring, turning foods

- **Stirring and turning foods** distributes heat quickly to the center of the dish and avoids overcooking at the outer edges of the food.

### Covering food

#### Cover food to:

- **Reduce** splattering
- **Shorten** cooking times
- **Retain** food moisture

All coverings that allow microwaves to pass through are suitable.

### Releasing pressure in foods

- **Several foods** (for example: baked potatoes, sausages, egg yolks, and some fruits) are tightly covered by a skin or membrane. This can cause the food to burst from steam building up in them during cooking. To relieve the pressure and to prevent bursting, **pierce** these foods before cooking with a fork, cocktail pick, or toothpick.

### Using standing time

- **Always allow food to stand** for a while after cooking. Standing time after defrosting, cooking, or reheating always improves the results since the temperature will then be evenly distributed throughout the food.
- **The length of the standing time** depends on the volume and density of the food. Sometimes it can be as short as the time it takes you to remove the food from the oven and take it to the serving table. However, with larger, denser food, the standing time may be as long as 10 minutes.



## Arranging food

For best results, distribute food evenly on the plate. You can do this in several ways:

- **If you are cooking several items of the same food**, such as baked potatoes, **place** them in a ring pattern for uniform cooking.
- **When cooking foods of uneven shapes or thickness, such as chicken breasts**, **place** the smaller or thinner area of the food towards the center of the dish where it will be heated last.
- **Layer thin slices of meat** on top of each other.
- **When you cook or reheat whole fish**, **score** the skin – this prevents cracking. Shield the tail and head of whole fish with small pieces of foil to prevent overcooking but ensure the foil does not touch the sides of the oven.
- **Do not** let food or a container touch the top or sides of the oven. This will prevent possible arcing.

## Using aluminum foil containers

Metal containers should not be used in a microwave oven. There are, however, some exceptions. If you have purchased food which is prepackaged in an aluminum foil container, then refer to the instructions on the package. When using aluminum foil containers, cooking times may be longer because microwaves will only penetrate the top of the food.

If you use aluminum containers without package instructions, follow these guidelines:

- **Place** container in a glass bowl and add some water so that it covers the bottom of the container, not more than  $\frac{1}{4}$  inch (6 mm) high. This ensures even heating of the container bottom.
- **Always remove** the lid to avoid damage to the oven.
- **Use only** undamaged containers.
- **Do not use** containers taller than  $\frac{3}{4}$  inch (19 mm).
- **Container must be** at least half filled.
- **To avoid arcing**, there must be a minimum  $\frac{1}{4}$  inch (6 mm) between the aluminum container and the walls of the oven and also between two aluminum containers.
- **Always place** container on turntable.
- **Reheating food** in aluminum foil containers usually takes up to double the time compared to reheating in plastic, glass, china, or paper containers. The time when food is ready will vary depending upon the type of container you use.
- **Let food stand** for 2 to 3 minutes after heating so that heat is spread evenly throughout container.

## Cooking you should not do in your microwave oven

- **Do not** do canning of foods in the oven. Closed glass jars may explode, resulting in damage to the oven.
- **Do not** use the microwave oven to sterilize objects (baby bottles, etc.). It is difficult to maintain the high temperature required for safe sterilization.

# Caring for Your Microwave Oven

Your CRISPWAVE microwave oven has a **stainless steel interior**. Unlike painted steel interiors found in most other microwave ovens, the surface will not chip, rust or corrode. Over time, stains can occur on the stainless steel surface as the result of food particles splattering during cooking. This is normal.

- **Do not use** metal scouring pads, steel wool or soap-filled scouring pads on the inside oven cavity. They will scratch the surface.
- **Rub** in the direction of the grain line to avoid marring the surface.
- **Always wipe dry** to avoid water marks.
- **If commercial cleaners are used**, follow label directions. If product contains chlorine (bleach), wipe thoroughly with clean water and dry with a soft, lint-free cloth. Chlorine is a corrosive substance.

**For interior surfaces:** Wash often with warm, sudsy water and a sponge or soft cloth. Use only mild, nonabrasive soaps or a mild detergent. Be sure to keep the areas clean where door and oven frame touch when closed. **Wipe** well with clean water.

For stubborn soil, **boil** 1 cup (250 mL) of water in the oven for 2 or 3 minutes. Steam will soften the soil. To get rid of odors inside the oven, **boil** 1 cup (250 mL) of water with lemon juice or vinegar.

**For exterior surfaces and control panel:** Use a soft cloth with spray glass cleaner. Apply the spray glass cleaner to the soft cloth; do not spray directly on the oven.

**NOTE: Abrasive cleaners, steel-wool pads, gritty wash cloths, some paper towels, etc.,** can damage the control panel and the interior and exterior oven surfaces.

**To clean turntable and turntable support, wash** in mild, sudsy water; for heavily soiled areas, **use** a mild cleanser and scouring sponge. The turntable and turntable support are dishwasher safe.

You can remove the glass turntable to clean the oven cavity floor; however, this oven is designed to operate with the turntable in place. **Do not** operate the microwave oven when the turntable is removed for cleaning. See the “how your microwave oven works” section for more information about the turntable.

**To clean the Broiling Grid, wash** with steel-wool pad and warm, soapy water. Grid is dishwasher-safe.

**To clean CRISPWARE™ Crisper Pan, wash** in mild, sudsy water; for heavily soiled areas **use** a mild cleanser and scouring sponge. Pan is dishwasher safe.

CLEANING TASK	WHAT TO USE	HOW TO CLEAN
Routine cleaning and fingerprints	Liquid detergent/soap and water, or all-purpose cleaner	Wipe with damp cloth or sponge, then wipe with clean water and dry.
Stubborn stains and baked-on residue	Mildly abrasive cleanser or stainless-steel cleaners	To avoid marring the surface, rub in the direction of grain lines with a damp cloth or sponge and cleanser. Wipe thoroughly with clean water. Repeat if necessary.
Hard water spots	Vinegar	Swab or wipe with cloth. Wipe with clean water and dry.

# Questions and Answers

QUESTIONS	ANSWERS
Can I operate my microwave oven without the turntable or turn the turntable over to accommodate a large dish?	No. If you remove or turn over the turntable, you will get poor cooking results. Dishes used in your oven must fit on the turntable.
Can I use a rack in my microwave oven so that I may reheat or cook on two levels at a time?	You can use a rack only if rack is supplied with your microwave oven. Use of any rack not supplied with the microwave oven can result in poor cooking performance and/or arcing.
Can I use either metal or aluminum pans in my microwave oven?	Usable metal includes aluminum foil for shielding (use small, flat pieces), small skewers, and shallow foil trays (if tray is $\frac{3}{4}$ inch [19 mm] deep and half filled with food to absorb microwave energy). When broiling or using CRISP, use the specially designed CRISPWARE™ Crisper Pan that comes with your oven. Never allow metal to touch walls or door. (For more information, see “Cooking tips” in the “Cooking Guide” section.)
Is it normal for the turntable to turn in either direction?	Yes. The turntable rotates clockwise or counterclockwise, depending on the rotation of the motor when the cooking cycle begins.
Sometimes the door of my microwave oven appears wavy. Is this normal?	This appearance is normal and does not affect the operation of your oven.
What are the humming noises that I hear when my microwave oven is operating?	You hear the sound of the transformer when the magnetron tube cycles on.
Why does the dish become hot when I microwave food in it? I thought that this should not happen.	As the food becomes hot it will conduct the heat to the dish. Also, when broiling remember that the Crisper Pan is made of a special material that absorbs microwave energy, making the pan very hot for browning. Use hot pads or the Crisper Pan handle to remove food after cooking and broiling.
What does “standing time” mean?	“Standing time” means that food should be removed from the oven and covered for additional time to allow it to finish cooking. This frees the oven for other cooking.
Can I pop popcorn in my microwave oven? How do I get the best results?	Yes. Pop packaged microwave popcorn following manufacturer’s guidelines or use the preprogrammed Popcorn pad. Do not use regular paper bags. Use the “listening test” by stopping the oven as soon as the popping slows to a “pop” every one or two seconds. Do not repop unpopped kernels. Do not pop popcorn in glass utensils.



## Questions and Answers

QUESTIONS	ANSWERS
Why does steam come out of the air exhaust vent?	Steam is normally produced during cooking. The microwave oven has been designed to vent this steam out the top vents.
How does my CRISPWARE™ Crisper Pan aid browning and crisping?	The bottom of your Crisper Pan is coated with a special material that absorbs the magnetic part of the microwave energy. This material becomes very hot and transfers heat to the bottom of the Crisper Pan for higher temperature cooking.
Sometimes I notice sparking when broiling. What causes this?	Sparking is caused by burning off of fat from past cooking. It will stop when fat is all burned off of the oven.

# Troubleshooting

Most cooking problems often are caused by little things you can find and fix without tools of any kind. Check the lists below and on the next page before calling for assistance or service. If you still need help, see the "Requesting Assistance or Service" section.

## If nothing operates, check the following:

- Is the microwave oven wired into a live circuit with the proper voltage?  
(See the Installation Instructions.)
- Have you blown a household fuse or tripped a circuit breaker?
- Has the electric company experienced a power failure?

## Other possible problems and their causes:

PROBLEM	CAUSE
<b>The microwave oven will not run</b>	<ul style="list-style-type: none"> <li>• The door is not firmly closed and latched.</li> <li>• You did not touch EASY MINUTE START.</li> <li>• You did not follow directions exactly.</li> <li>• An operation that was programmed earlier is still running.</li> <li>• You have not entered numbers after touching MICRO COOK.</li> </ul>
<b>Microwave cooking times seem too long</b>	<ul style="list-style-type: none"> <li>• The electric supply to your home or wall outlets is low or lower than normal. Your electric company can tell you if the line voltage is low. Your electrician or service technician can tell you if the outlet voltage is too low.</li> <li>• The cook power is not at the recommended setting.</li> <li>• Larger amounts of food need longer cooking times.</li> </ul>
<b>The turntable will not turn</b>	<ul style="list-style-type: none"> <li>• The turntable is not correctly in place. Make sure the turntable is correct-side up and is sitting securely on center shaft.</li> <li>• The support is not operating correctly. Remove turntable, check that the turntable support is properly in place and restart oven. If turntable support does not move, call a designated service technician for repair. Cooking without the turntable can give you poor results.</li> </ul>
<b>The display shows a time counting down, but the oven is not cooking</b>	<ul style="list-style-type: none"> <li>• The oven door is not closed completely.</li> <li>• You have set the controls as a kitchen timer. Touch OFF/CANCEL to cancel the Minute Timer.</li> </ul>
<b>You do not hear the Programming Tone</b>	<ul style="list-style-type: none"> <li>• You have disabled the tones. See "Using Your Electric Convection Oven" in your Lower Electric Convection Oven Use and Care Guide on page 7.</li> </ul>
<b>Smoke is coming out of the vent during broiling</b>	<ul style="list-style-type: none"> <li>• This is normal, just as in conventional broiling.</li> </ul>
<b>"F" followed by a number appears on Display</b>	<ul style="list-style-type: none"> <li>• There has been a command pad failure. Call for service. See "Requesting Assistance or Service" on pages 40 or 41. Touch Number pad 1 to clear failure code from Display.</li> </ul>

If none of these items is causing your problem, see "Requesting Assistance or Service" section.

# Requesting Assistance or Service

Before calling for assistance or service, please check the "Troubleshooting Guide" section. It may save you the cost of a service call. If you still need help, follow these instructions.

## If you need assistance or service in U.S.A.:

### Call the KitchenAid Consumer



**Assistance Center toll free: 1-800-422-1230.**  
**Our consultants are available to assist you.**

When calling:

Please know the purchase date, and the complete model and serial number of your appliance (see the "A Note to You" section). This information will help us to better respond to your request.

#### **Our consultants provide assistance with:**

- Features and specifications on our full line of appliances.
- Installation information.

- Use and maintenance procedures.
- Accessory and repair parts sales.
- Specialized customer assistance (Spanish speaking, hearing impaired, limited vision, etc.).
- Referrals to local dealers, service companies, and repair parts distributors.

**KitchenAid designated service technicians** are trained to fulfill the product warranty and provide after-warranty service, anywhere in the United States.

To locate the KitchenAid designated service company in your area, you can also look in your telephone directory Yellow Pages.

## If you need replacement parts

If you need to order replacement parts, we recommend that you only use factory specified parts. These parts will fit right and work right, because they are made with the same precision used to build

every new KITCHENAID® appliance. To locate factory specified replacement parts in your area, call our Consumer Assistance Center telephone number or your nearest designated service center.

## For further assistance

If you need further assistance, you can write to KitchenAid with any questions or concerns at:

KitchenAid Brand Home Appliances  
Consumer Assistance Center  
c/o Correspondence Dept.  
2000 North M-63  
Benton Harbor, MI 49022-2692

Please include a daytime phone number in your correspondence.



## If you need assistance or service in Canada:

### Call the KitchenAid Consumer



**Assistance Center toll free:  
8:30 a.m. - 6 p.m. (EST) at  
1-800-461-5681. Our  
consultants are available  
to assist you.**

#### When calling:

Please know the purchase date, and the complete model and serial number of your appliance (see the "A Note to You" section). This information will help us to better respond to your request.

#### Our consultants provide assistance with:

- Features and specifications on our full line of appliances.

- Accessory and repair parts sales.
- Specialized customer assistance (French speaking, hearing impaired, limited vision, etc.).
- Referrals to local dealers, service companies, and repair parts distributors.

**KitchenAid designated service technicians** are trained to fulfill the product warranty and provide after-warranty service, anywhere in Canada.

To locate the KitchenAid designated service company in your area, you can also look in your telephone directory Yellow Pages.

#### If you need service:

Contact Inglis Limited Appliance Service from anywhere in Canada at **1-800-807-6777**.

## If you need replacement parts

If you need to order replacement parts, we recommend that you only use factory specified parts. These parts will fit right and work right, because they are made with the same precision used to build

every new KITCHENAID® appliance. To locate factory specified replacement parts in your area, call our Consumer Assistance Center telephone number or your nearest designated service center.

## For further assistance

If you need further assistance, you can write to KitchenAid with any questions or concerns at:

Consumer Relations Department  
KitchenAid Canada  
1901 Minnesota Court  
Mississauga, Ontario L5N3A7

Please include a daytime phone number in your correspondence.

# KitchenAid®

## Electric Built-In Microwave

# Warranty

LENGTH OF WARRANTY:	KITCHENAID WILL PAY FOR:	KITCHENAID WILL NOT PAY FOR:
<b>ONE-YEAR FULL WARRANTY</b> FROM DATE OF PURCHASE.	Replacement parts and repair labor costs to correct defects in materials or workmanship. Service must be provided by a KitchenAid designated servicing company.	<p><b>A. Service calls to:</b></p> <ol style="list-style-type: none"> <li>1. Correct the installation of the microwave oven.</li> <li>2. Instruct you how to use the microwave oven.</li> <li>3. Replace house fuses or correct house wiring.</li> </ol> <p><b>B. Repairs when oven is used in other than normal single-family household use.</b></p>
<b>SECOND-THROUGH FIFTH-YEAR LIMITED WARRANTY</b> FROM DATE OF PURCHASE.	Replacement parts for microwave magnetron or any oven electric element to correct defects in materials or workmanship. Replacement parts for solid state touch control system to correct defects in materials or workmanship.	<p><b>C. Damage resulting from accident, alteration, misuse, abuse, fire, flood, acts of God, improper installation, installation not in accordance with local electrical codes, or use of products not approved by KitchenAid.</b></p> <p><b>D. Any labor costs during the limited warranties.</b></p> <p><b>E. Replacement parts or repair labor costs for units operated outside the United States or Canada.</b></p>
<b>SECOND-THROUGH TENTH-YEAR LIMITED WARRANTY</b> FROM DATE OF PURCHASE.	Replacement parts for the stainless steel oven cavity/inner door if the part rusts through due to defects in materials or workmanship.	<p><b>F. Pickup and delivery. This product is designed to be repaired in the home.</b></p> <p><b>G. Repairs to parts or systems resulting from unauthorized modifications made to the appliance.</b></p> <p><b>H. In Canada, travel or transportation expenses for customers who reside in remote areas.</b></p>

3/99

**KITCHENAID AND KITCHENAID CANADA DO NOT ASSUME ANY RESPONSIBILITY FOR INCIDENTAL OR CONSEQUENTIAL DAMAGES.** Some states or provinces do not allow the exclusion or limitation of incidental or consequential damages, so this exclusion or limitation may not apply to you. This warranty gives specific legal rights and you may also have other rights which vary from state to state or province to province.

**Outside the United States and Canada, a different warranty may apply. For details, please contact your authorized KitchenAid dealer.**

If you need assistance or service, first see the "Troubleshooting" section of this book. After checking "Troubleshooting," additional help can be found by checking the "Requesting Assistance or Service" section. In the U.S.A., call our Consumer Assistance Center at **1-800-422-1230**. In Canada, call KitchenAid Canada at one of the telephone numbers listed in the "Requesting Assistance or Service" section.