

Master Series

Full-Size Gas Convection Ovens

Installation, Operation and Maintenance Manual

This manual is updated as new information and models are released. Visit our website for the latest manual.

models

MCO-GS-10S
MCO-GD-10S
MCO-GS-20S
MCO-GD-20S
MCO-GS-10M
MCO-GD-10M
MCO-GS-20M
MCO-GD-20M



MCO-GS-10M

Original Document



SAFETY NOTICES

WARNING:

This product contains chemicals known to the State of California to cause cancer and/or birth defects or other reproductive harm. Installation and servicing of this product could expose you to airborne particles of glass wool/ceramic fibers. Inhalation of airborne particles of glass wool/ceramic fibers is known to the State of California to cause cancer. Operation of this product could expose you to carbon monoxide if not adjusted properly. Inhalation of carbon monoxide is known to the State of California to cause birth defects or other reproductive harm.

Keep appliance area free and clear of combustibles.

**FOR YOUR SAFETY:
DO NOT STORE OR USE GASOLINE
OR OTHER FLAMMABLE VAPORS OR
LIQUIDS IN THE VICINITY OF
THIS OR ANY OTHER
APPLIANCE**

**WARNING:
IMPROPER INSTALLATION, ADJUSTMENT,
ALTERATION, SERVICE OR MAINTENANCE
CAN CAUSE PROPERTY DAMAGE, INJURY,
OR DEATH. READ THE INSTALLATION,
OPERATING AND MAINTENANCE
INSTRUCTIONS THOROUGHLY
BEFORE INSTALLING OR
SERVICING THIS EQUIPMENT**

PLEASE READ ALL SECTIONS OF THIS MANUAL AND RETAIN FOR FUTURE REFERENCE.

THIS PRODUCT HAS BEEN CERTIFIED AS COMMERCIAL COOKING EQUIPMENT AND MUST BE INSTALLED BY PROFESSIONAL PERSONNEL AS SPECIFIED.

IN THE COMMONWEALTH OF MASSACHUSETTS THIS PRODUCT MUST BE INSTALLED BY A LICENSED PLUMBER OR GAS FITTER. APPROVAL NUMBER: G-1-07-05-28

For Your Safety:

Post in a prominent location, instructions to be followed in the event the user smells gas. This information shall be obtained by consulting your local gas supplier.

Users are cautioned that maintenance and repairs must be performed by a Garland authorized service agent using genuine Garland replacement parts. Garland will have no obligation with respect to any product that has been improperly installed, adjusted, operated or not maintained in accordance with national and local codes or installation instructions provided with the product, or any product that has its serial number defaced, obliterated or removed, or which has been modified or repaired using unauthorized parts or by unauthorized service agents.

For a list of authorized service agents, please refer to the Garland web site at <http://www.garland-group.com>.

The information contained herein, (including design and parts specifications), may be superseded and is subject to change without notice.



CONTENTS





SAFETY NOTICES.....	2	Electronic Control.....	12	
GENERAL INFORMATION	5	Start Up.....	12	
Model Numbers	5	Manual Mode	13	
Warranty	5	Operating the Controls	14	
Serial Plate Location.....	5	Cook-N-Hold Operation	14	
Accessories	5	Settings Mode	14	
DIMENSIONS & SPECIFICATIONS	6	Cleaning Mode.....	14	
INSTALLATION	7	PERFORMANCE RECOMMENDATIONS AND	GENERAL SAFETY PRECAUTIONS.....	15
Entry Clearance	7	PROBLEMS / SOLUTIONS	16	
Installation Clearance	7	COOKING GUIDE.....	17	
Installation Of Ovens Equipped With Casters ..	7	COOK AND HOLD	18	
Installation Of Double Deck Models.....	8	CLEANING & MAINTENANCE.....	19	
Gas Connection.....	9	Break-In Period.....	19	
Electrical Connection	9	Exterior Cleaning.....	19	
Ventilation & Air Supply	9	Interior Cleaning	19	
Installation of a Direct Flue	9	Fan Area Maintenance.....	19	
Testing & Lighting Instructions	10	Motor Care.....	19	
OPERATING INSTRUCTIONS.....	11			
Master 200 Solid State Control With				
Electromechanical Timer.....	11			
In Off Mode.....	11			
Start Up.....	11			
Fan Speed	11			
Lights.....	11			
Cool Down.....	11			
Temperature	11			
Timer	11			



THIS PAGE INTENTIONALLY LEFT BLANK

GENERAL INFORMATION

Model Numbers

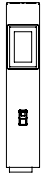
Model		Deep Depth	Single Deck	Double Deck	Master ₂₀₀ Control	Digital Control
						
MCO-GS-10S	✓		✓		✓	
MCO-GD-10S		✓	✓		✓	
MCO-GS-20S	✓			✓	✓	
MCO-GD-20S		✓		✓	✓	
MCO-GS-10M	✓		✓			✓
MCO-GD-10M		✓	✓			✓
MCO-GS-20M	✓			✓		✓
MCO-GD-20M		✓		✓		✓

Warranty

Visit www.Garland-Group.com to view or download a copy of your warranty.

Serial Plate Location

When corresponding with the factory or your local authorized factory service center regarding service problems or replacement parts, be sure to refer to the particular unit by the correct model number (including the prefix and suffix letters and numbers) and the warranty serial number.

- The serial plate is affixed to the upper right corner of the left body panel.



Accessories

- Direct Connect Vent

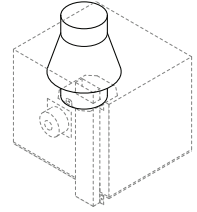

- Stainless steel open base with rack guides and shelf (in lieu of 25-inch legs) for extra rack/pan storage, single deck oven only

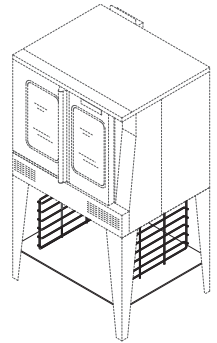

- Casters (set of 4) with front brakes



- Extra oven rack



- Deck fasteners for stainless steel flanged feet

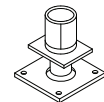

- Gas flex hose and quick disconnect (3/4-inch NPT x 5-feet) with restraining device
- Removable stainless steel drip pan

DIMENSIONS & SPECIFICATIONS

Single-Deck Models	Int. Dimensions: In (mm)			Ext. Dimensions: In (mm)			Ship Wt	Ship Dim.
	W	H	D	W	H*	D	Lbs/kg	Cubic Ft.
Standard Depth	29 (736)	24 (610)	24 (610)	38 (965)	57-1/2 (1461)	41-1/4(1048)	515/230	64
Deep Depth	29 (736)	24 (610)	28 (711)	38 (965)	57-1/2 (1461)	44-1/2(1130)	545/245	64

Double-Deck Models	Int. Dimensions: In (mm)			Ext. Dimensions: In (mm)			Ship Wt.	Ship Dim.
	W	H	D	W	H*	D	2@Lbs/kg	Cubic Ft.
Standard Depth	29 (736)	24 (610)	24 (610)	38 (965)	70-1/2 (1791)	41-1/4(1048)	1030/465	128
Deep Depth	29 (736)	24 (610)	28 (711)	38 (965)	70-1/2 (1791)	44-1/2(1130)	1090/490	128

* Height with legs or with standard casters. Height with low profile casters (double deck) is 68-1/2" (1740mm).

Models	Input Ratings, Nat & Pro			Electrical Specifications	
	BTU/hr	kW Equiv.	Gas Inlet	120V/1Ph.	240V/1Ph.
Single Deck	60,000 /80,000*	17.6 /23.4*	(1) @ 3/4" NPT	(1)@9.8A	(1)@ 5.2A
Double Deck	120,000 /160,000*	35.2/46.9*	(1) @1" NPT	(2)@9.8A	(2)@ 5.2A

*Optional burner input rating for natural gas only.

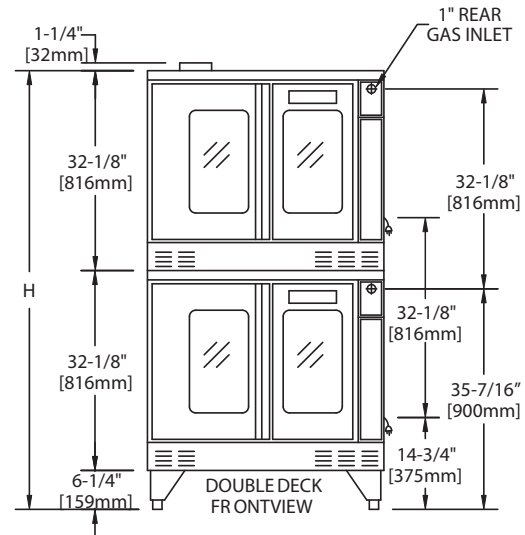
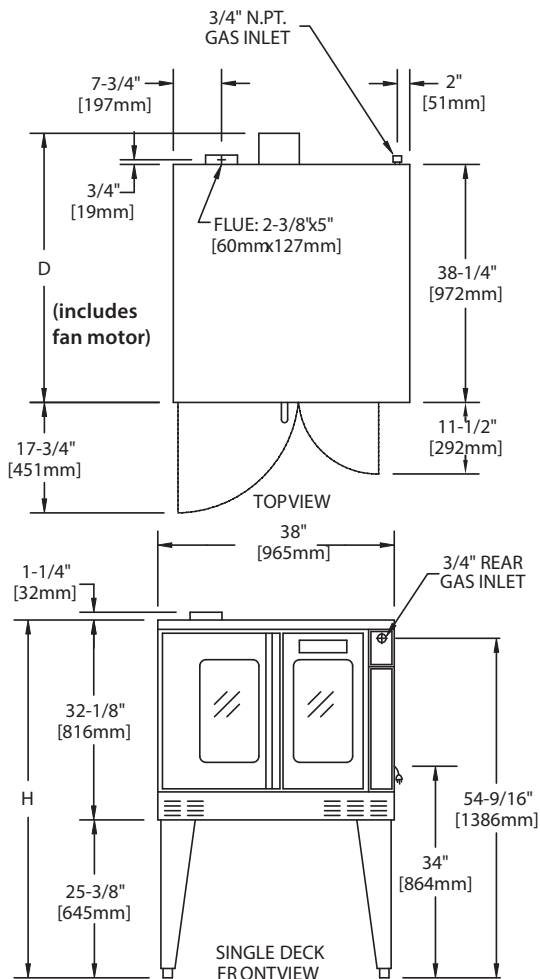

Operating Pressure:

Natural: 4" WC (10 mbar)
 Propane: 10" WC (25 mbar)
 Max 13.8" WC @ 70°F (21°C)
 NOTE: Data applies only to North America

Notes:

1. Standard electrical specifications include motor requirements.
2. (120V units) 115V 0.6 HP, 2-speed motor; 1430 and 1670 rpm 60Hz
3. (240V units) 200-240V, 0.6 HP, 2-speed motor; 1430 and 1670 rpm, 60Hz
4. A 6 ft. line cord is provided for each 120V deck with a (NEMA #5-15P) plug.
5. Garland recommends a separate 15 AMP circuit for each 120V unit.

Gas Input ratings shown here are for installations up to 2,000-ft. (610m) above sea level. Specify altitudes over 2,000 ft. Commercial cooking equipment requires an adequate ventilation system. For additional information, refer to the National Fire Protection Association's standard NFPA96, "Vapor Removal from Cooking Equipment." (NOTE: For North America only) Please specify gas type when ordering.



INSTALLATION

Entry Clearance

- Crated: 47" (1194mm)
- Uncrated: 32-1/2" (826mm)

Installation Clearance

NOTE: Always provide adequate clearance for maintenance and operation.

- Installation adjacent to combustible and non-combustible wall, minimum clearance:

	Left Side	Control Side	Rear
Single-Deck	1" (26 mm)	1" (26 mm)	3" (77 mm)
Double-Deck	1" (26 mm)	2" (51 mm)	3" (77 mm)

- Installation near high heat producing equipment, minimum clearance:

	Left Side	Control Side	Rear
Single-Deck	1" (26 mm)	6" (153 mm)	3" (77 mm)
Double-Deck	1" (26 mm)	6" (153 mm)	3" (77 mm)

Notice

Avoid installing ovens near equipment, such as char-broilers or fryers, which generate high heat and high grease laden air.

- Clearance for Service (recommendation):

	Control Side, minimum
Single-Deck	12" (305 mm)
Double-Deck	12" (305 mm)

NOTE: Install units with casters in very tight locations for ease of service.

The importance of the proper installation of Commercial Gas Cooking Equipment cannot be over stressed. Proper performance of the equipment is dependent, in great part, on the compliance of the installation with the manufacturer's specifications. Installation must conform to local codes or, in the absence of local codes, with the National Fuel Code, ANSI Z223.1, Natural Gas Installation Code, CAN/CGA-B149.1, or the Propane Installation Code, CAN/CGA-B149.2, as applicable.

Before assembly and connection, check gas supply.

- The type of gas for which the unit is equipped is stamped on the data plate located on the upper right corner of the left body side panel. Connect a unit stamped "NAT" only to natural gas; connect a unit stamped "PRO" only to propane.
- If it is a new installation, have gas authorities check meter size and piping to assure that the unit is supplied with sufficient amount of gas pressure required to operate the unit.

- If it is additional or replacement equipment, have gas authorities check pressure to make certain that existing meter and piping will supply fuel at the unit with not more than 1/2" water column pressure drop.

NOTE: When checking pressure be sure that all other equipment on the same gas line is on. An internal pressure regulator is supplied with GARLAND Convection Ovens. Regulator is preset to deliver gas at pressure shown on the rating plate.

The appliance and its individual shut-off valve must be disconnected from the gas supply piping system during any pressure testing of that system at test pressures in excess of 1/2 PSI (3.45 kPa).

The appliance must be isolated from the gas supply piping system by closing its individual manual shut-off valve during any pressure testing of the gas supply piping system at test pressures equal to or less than 1/2 PSI (3.45 kPa).

Installation Of Ovens Equipped With Casters

- For an appliance equipped with casters, the installation shall be made with a connector that complies with the Standard for Connectors for Movable Gas Appliances, ANSI Z21.69 / CSA 6.16, and a quick-disconnect device that complies with the Standard for Quick-Disconnect Devices for Use With Gas Fuel Appliances, ANSI Z21.41 / CSA 6.9, and adequate means must be provided to limit the movement of the appliance without depending on the connector and the quick-disconnect device or its associated piping to limit the appliance movement and the location(s) where the restraining means may be attached to the appliance shall be specified.
- The front casters of the unit are equipped with brakes to limit the movement of the oven without depending on the connector and any quick-disconnect device or its associated piping to limit the appliance movement.
- The restraint can be attached to the unit near the gas inlet. If the restraint is disconnected, be sure to reconnect the restraint after the oven has been returned to its originally installed position.

INSTALLATION Continued

Installation Of Double Deck Models

- A. Position insert in bottom leg opening and tap insert up into leg till it seats at collar. Attach six inch (6") legs to lower oven section. Raise unit or lay on its left side. Place the front legs on the oven so as to line up with four (4) attaching bolt holes. Secure leg to oven frame using (4) 3/8-16 x 3/4 bolts and washers provided. Repeat at rear of unit.
- B. Remove lower front cover of top deck (located under oven doors). Raise top deck into place and line up body sides and back of the unit. Fasten the rear of the units together, with the stacking bracket, using (6) 1/4-20 machine screws, lock washers and nuts, (provided).
- C. Install the interconnecting flue parts, carefully following the instructions contained in the stacking kit. Pay particular attention to the type of ovens you are stacking and be sure to follow the corresponding instructions.
- D. Assemble the stacking pipes provided in the stacking kit as shown in the diagram on this page. This allows both ovens to be supplied by a single gas line. The minimum recommended size of a single supply line for two stacked ovens is 1 inch. Use a pipe thread compound that is intended for use on propane gas piping and be sure to check for leaks before finalizing the installation.
- E. Check leveling of unit four (4) ways (using a common carpenter's level on the rack inside the oven).
- F. Plug the cord set of each unit into a 115-Volt power supply outlet.
- G. Maintain clearance from combustibles.

Each gas appliance shall be located with respect to building construction and other equipment so as to permit access to the appliance. Such access and clearance may be necessary for servicing and cleaning.

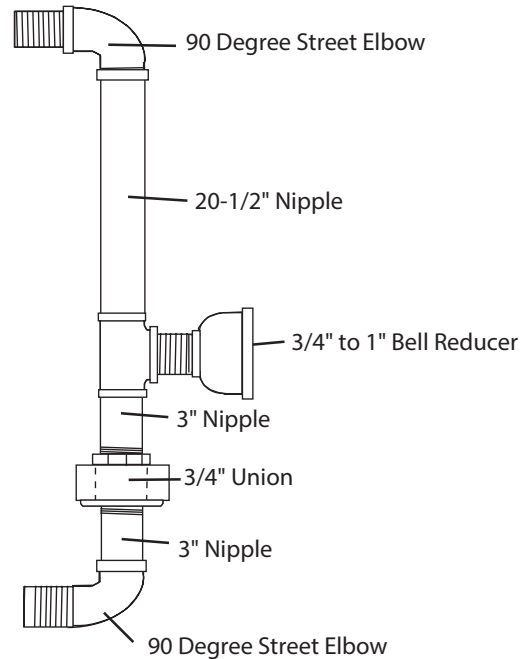

CAUTION:
**DISCONNECT BOTH UNITS FROM
ELECTRICAL SUPPLY BEFORE SERVICING.**

POWER FAILURE
**In the event of a power failure, no attempt should be
made to operate this oven.**

IMPORTANT
**All gas burners and pilots need sufficient air
to operate and large objects should not be placed in
front of this oven, which would
obstruct the airflow through the front.
Objects should not be placed on main top
rear of oven while in use. This could obstruct the venting
system of the unit's flue products.**

INSTALLATION Continued

Gas Connection

The 1" NPT inlet at the rear must be considered in piping the gas supply for double stack units or ¾" NPT for individual (or single deck) connections. Undersized gas supply line(s) may restrict the gas supply and affect performance. If other gas appliances are supplied by the same supply line, the supply line must be sized to carry the combined volume without causing more than 1/2" pressure drop at the manifold of each appliance on the line at full rate.

Recommended supply pressures are 7" WC, (NAT), and 11" WC, (PRO); ± 5%. (Must not exceed 13.8" WC [NAT], and 15" WC [PRO]).

Electrical Connection

A 15 AMP service must be provided for each oven. For 115 VAC usage, a cord and plug (NEMA #5-15P) is provided but connection to the electrical service must be electrically grounded in accordance with local codes, or in the absence of local codes, with the National Electrical Code, ANSI/NFPA 70, or the Canadian Electrical Code, CSA C22.2, as applicable.

This appliance is equipped with a three-prong (grounding) plug for your protection against shock hazard and should be plugged directly into a properly grounded three-prong receptacle.

DO NOT CUT OR REMOVE THE
GROUNDING PRONG FROM THIS PLUG.

A wire diagram is affixed to the rear of the unit.

Ventilation & Air Supply

Proper ventilation is highly important for good operation. There are only two choices for properly venting an oven: 1) canopy hood style or 2) direct venting. The ideal method of venting a GAS Convection Oven is through the use of a properly designed canopy, which should extend 6" (150 mm), beyond all sides of the appliance and 6'6" (1950 mm) from the floor.

A strong exhaust fan will create a vacuum in the room. For an exhaust system vent to work properly, exhaust and make-up air must be balanced properly. For proper air balance contact your local H.V.A.C. contractor.

All gas burners and pilots need sufficient air to operate and large objects should not be placed in front of this oven, which would obstruct the airflow through the front.

Installation of a Direct Flue

When the installation of a canopy type exhaust hood is impossible the oven may be direct vented. Before direct venting check your local codes on ventilation, in the absence of local codes, refer to the National Fuel Code NFPA 54, ANSI Z223.1 (latest revision).

If the unit is to be connected directly to a direct flue, it is necessary that draft diverter be installed to insure proper ventilation.

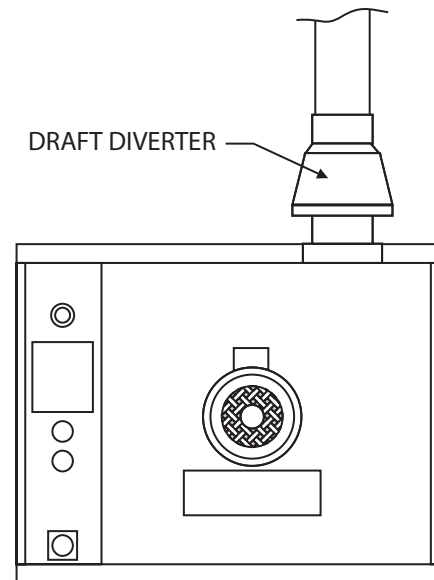

Direct venting, should be positioned on the main top and fastened with sheet metal screws provided.

NOTE: Each oven has been factory tested and adjusted prior to shipment. It may be necessary to further adjust the oven as part of a proper installation. Such adjustments are the responsibility of the installer. Adjustments are not considered defects in material and workmanship, and they are not covered under the original equipment warranty.

DO NOT UNDER SIZE VENT PIPE!

This can cause resistance to flow and impede good venting. We suggest that if a horizontal run must be used it should rise no less than 1/4" (6.25mm) for each linear foot of run, and after a total of 180° of bends you should increase the size of stove pipe by two (2") inches. The flue should rise 2' (60cm) to 3' (90cm) above the roofline or 2' (60cm) to 3' (90cm) above any portion of a building within a horizontal distance of 10 (3 meters) feet.

The following diagram is only one example from the National Fuel Gas Code Book NFPA 54, ANSI Z223.1, 7.5.3:

INSTALLATION continued

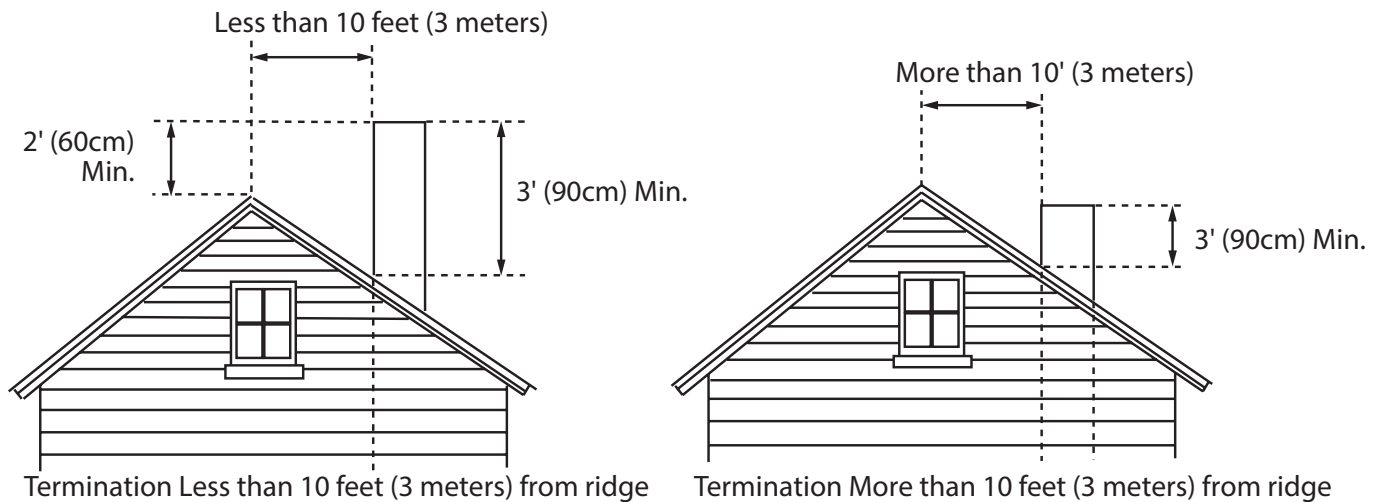

Testing & Lighting Instructions

1. Turn on main gas valve. Remove the lower front cover and the service panel above the control panel. Drop the control panel and leak test all fittings and connections upstream from the service valve located on the redundant combination gas valve. Should any gas leaks be detected, turn OFF main gas valve, correct the problem and retest.
2. Open shutoff valve located on the redundant combination gas valve. Activate control panel and set to desired temperature. The pilot burner is ignited by direct spark, main burners are then ignited by the pilot. Check all fittings again and correct any leaks and recheck.

Replace all service panels and covers before operation.

NOTE: All electronic ignition systems are supplied with a redundant gas valve. Therefore, the unit is not supplied with an external pressure regulator.

NOTE: During installation there will be air in the gas line. This air will have to bleed off before ignition can be established. The electronic ignition system has a ninety second lock-out as a safety device on all units. Therefore, several attempts may be required before pilot ignition is established, wait five minutes after each attempt.

FOR YOUR SAFETY: KEEP YOUR APPLIANCE AREA FREE FROM COMBUSTIBLES.

TO CONSERVE ENERGY:

Do not waste energy by leaving controls at high temperature settings during idle periods. Lower settings will keep oven warm and ready for next use period. Master 400 Series controls have an auto setback feature that is user programmable to help with these applications.

OPERATING INSTRUCTIONS

Master 200 Solid State Control With Electromechanical Timer

In Off Mode

When the oven is off, there are no lights or indicators.

Start Up

Press the Cook/Off/Cool Down rocker switch to the “Cook” position. The green lamp will light indicating the oven is powered in cook mode.

The oven will begin to heat to the temperature set on the thermostat dial. The amber lamp will light indicating the heat is active. As the heat cycles on and off to maintain the set temperature this light will go on and off accordingly.

The door must be closed for the oven to operate in cook mode. Opening the door will cause the heat to stop. The motor and fan will shut off. This is a safety feature.

Fan Speed

The fan speed can be either high (1670 RPM) or low (1430 RPM). The fan speed is controlled by the left rocker switch marked high and low.

Lights

The oven lights are activated by pressing the light switch on the control panel. This is a momentary switch and the lights will stay lit as long as this button is held in the on position. Lights will work whenever there is electrical power connected to the oven.

Cool Down

Pressing the Cook/Off/Cool Down rocker switch to the Cool Down position activates the fan and motor to cool the oven cavity. The door must be open slightly for the fan and motor to start. The heat is not active in this mode.

Optimal cool down will be achieved with the door open slightly. Opening the door too far will shut the fan and motor off. This is a patented safety feature.

Pressing the button to the OFF position cancels the cool down and turns the oven off.

Temperature

The temperature range is from 150°F to 500°F (66°C to 260°C) is controlled by rotating the temperature dial and aligning the indicator to the desired temperature.

Timer

The timer is set by rotating the dial clockwise aligning the indicator to the desired time cycle. The timer will count down from 2 minutes to 60 minutes. At the end of the timing cycle the buzzer will sound. The buzzer is turned off by rotating the dial counter clockwise to the off position,

NOTE: The timer does not control heating

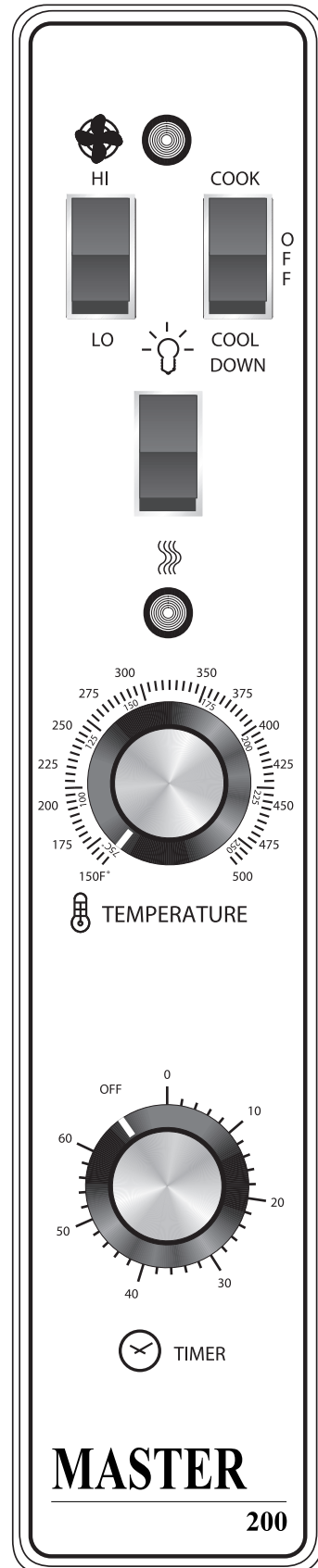

OPERATING INSTRUCTIONS Continued

Electronic Control

Start Up

When the controller is off the display will be blank. Pressing the main power switch ON will activate the controller and the splash screen (photo 1) displaying the software version and then the home screen (photo 2), will appear on the user interface. The home screen displays the four main icons of the control - the **Press and Go Menu** (square pattern) in the upper left, **Settings Mode** (gear cog) in the lower left, **Manual Mode** (chef's hat) in the upper right and the **Pause for Cleaning** (hand and cloth) button in the lower right.

Note that If the door is opened during a cooking mode, the fan and heat will stop, the interior light comes on, the control will pause and the display will indicate **door is open symbol** (see photo 3) until the door is closed. *This is a patented safety feature.* This period of pause allows time for removing product and restarting the cook cycle.

If one opens the door slightly for more than three seconds the oven will enter a **Cool Down** mode and deactivate the heat and turn the fan on high until the oven cavity temperature drops below 150°F (66°C). The Cool down will operate when the door is opened slightly (at least five degrees). Optimal cool-down will be achieved with the door open slightly. When the door opens wider, the Cool Down mode will deactivate and the display will indicate Door Open (Photo 3). This is a patented safety feature. Cool Down is not active during a cook cycle.



Photo 1



Photo 2



Photo 3

Press and Go Menu (square pattern)

Allows quick access to existing recipes (see photo 7).

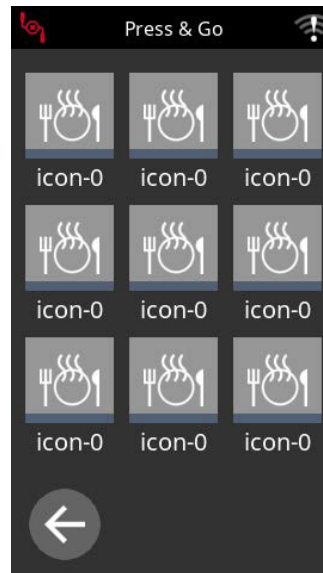

Photo 7

One need only select the desired icon.

OPERATING INSTRUCTIONS Continued

Manual Mode (chef's hat)

- Cook temperature (photo 5)
- Low or high fan speed or fan pulse mode whereby the fan will pulse on and off when the oven is in holding mode. (fan symbol photo 4 and 8)
- Set main cook timer (24 hour timer) (photo 8)
- Set secondary cook timer (24 hour timer) to allow for different cook times for different rack positions (photo 6)
- Turn interior light on/off (light symbol photo 4 and 8)
- Select Cook & Hold temperature (temperature appears in red -see photo 4)

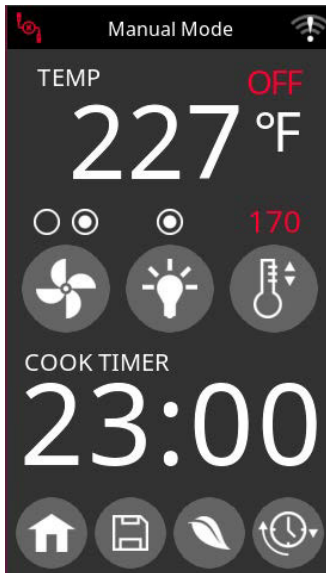

Photo 4

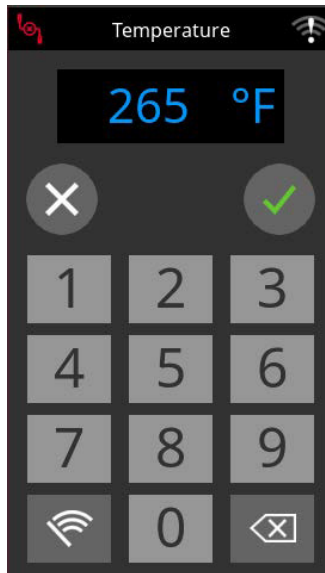

Photo 5

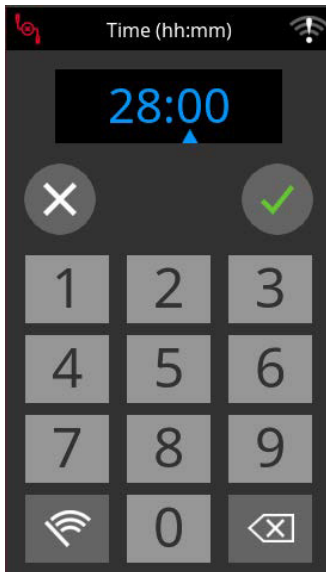

Photo 6



Photo 8

Manual Mode cont'd.

- Program/Save recipes (photo 13 and 14)
- Select one of nine default recipes (photo 15)
- Change icons and colour (photo 15)

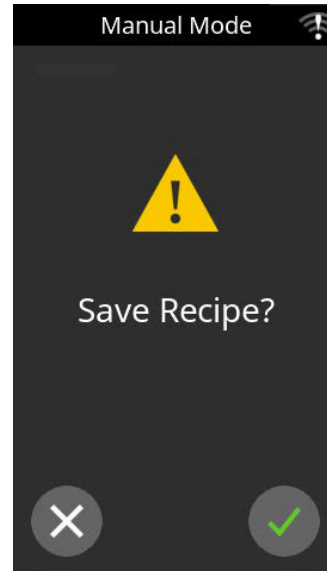

Photo 13



Photo 14

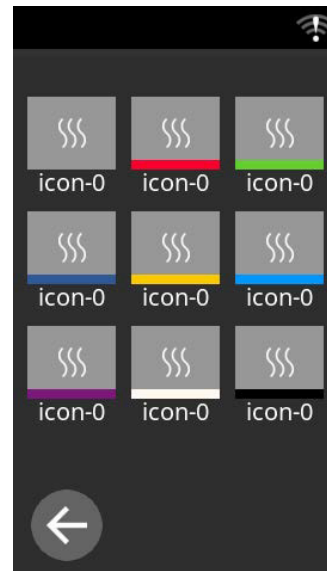

Photo 15



OPERATING INSTRUCTIONS Continued

Operating the Controls

Setting the cook temperature (from 150 deg. F to 500 deg. F (65 deg. C to 260 deg. C)) and time are done in the same manner (see photos 5 and 6).

When the timing cycle is started the display will count down from the Set time in minutes and seconds. Note that an alarm will sound when the set point temperature is reached and the cook time is completed.

Cook-N-Hold Operation

Pressing the **Cook-N-Hold** symbol (see photo 4 - thermometer symbol next to light bulb) activates the Cook-N-Hold mode. The display will show the hold temperature in red. At the end of the cook cycle, an audible alarm will sound and the display will change to count "up" the time the oven is on hold. The oven will switch to the programmed hold temperature. The timer will sound the alarm again after the hold time has elapsed.

Setting the cook temperature, hold temperature and time are done in the same manner (see photos 5 and 6). The desired temperature is shown on the display.

Pressing the enter symbol will start the timing cycle.

Settings Mode (Gear Wheel)

- To enter the Settings screen a password must be keyed in from the key pad (see photo 9). The **Settings Mode** allows one to (see photo 10):
- Select deg. F or deg. C
- Select ECO Mode Temperature
- Select Cook & Hold Temperature
- Select Alarm Volume
- Perform software updates via USB (accessibility to technicians only)

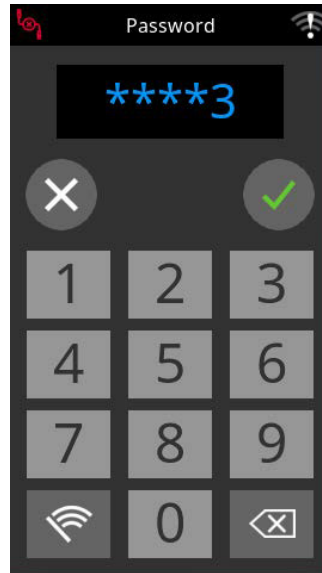

Photo 9

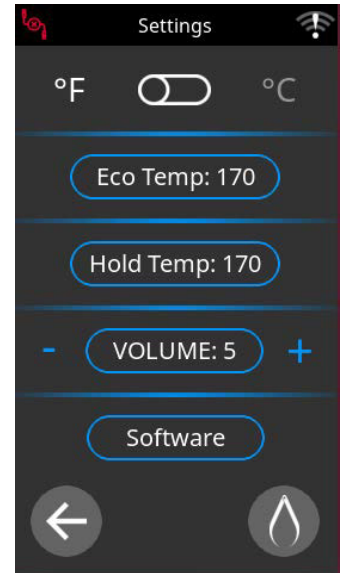

Photo 10

CLEANING MODE (Hand & Cloth - photo 11)

-In the cleaning mode the screen remains frozen for seven seconds to allow for cleaning between operators (see photo 12)

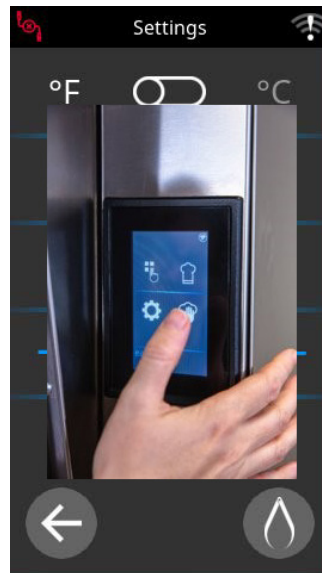

Photo 11

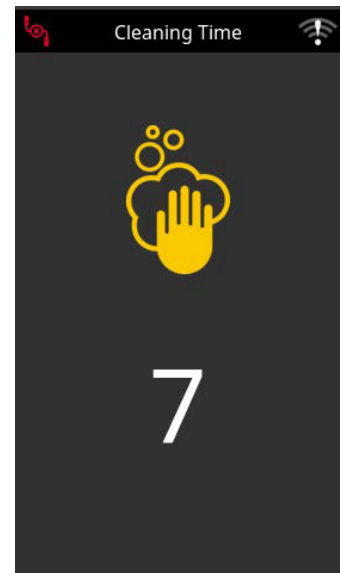

Photo 12

PERFORMANCE RECOMMENDATIONS AND GENERAL SAFETY PRECAUTIONS

1. Preheat oven thoroughly (approx. 20 minutes) before use.
 2. As a general rule, temperature should be reduced 25° to 50° from that used in a standard/conventional oven. Cooking time may also be shorter, so we suggest closely checking the first batch of each product prepared.
 3. Use the chart of suggested times and temperatures as a guide. These will vary depending upon such factors as size of load, temperature, and mixture of product (particularly moisture) and density of product.
 4. Keep a record of the times, temperature, and load sizes you establish for various products. Once you have determined these, they will be similar for succeeding loads.
 5. When practical, start cooking the lowest temperature product first and gradually work up to higher temperatures.
 6. If you find that your previous temperature setting is more than 10° higher than needed for succeeding loads, COOL DOWN to reach the desired temperature before setting a new cooking temperature.
 7. When loading oven, work as quickly as possible to prevent loss of heat.
 8. Oven will continue to heat even though the timer goes off. Product should be removed from the oven as soon as possible to avoid over cooking.
 9. Center pans on racks and load each shelf evenly to allow for proper air circulation within the cavity.
 10. When baking, weigh or measure the product in each pan to assure even cooking.
 11. When cooking six pans, use rack positions 1, 4, 6,8,10 and 12, starting from the top.
 12. Do not overload the oven. Six pans are suggested for most items, i.e., cakes, cookies, rolls, etc. However, the maximum (13 pans) may be used for fish sticks, chicken nuggets and hamburgers. Cooking times will have to be adjusted.
 13. Muffin pans should be placed in the oven back to front or with the short side of the pans facing the front. This results in the most evenly baked product.
 14. When re-thermalizing frozen casseroles, preheat the oven 100° over the suggested temperature. Return to cooking temperature when the oven is loaded. This will help compensate for the introduction of a large frozen mass into the cavity.
 15. Use pan extenders or two inch deep 18" x 26" pans for batter type products which weigh more than eight pounds, i.e., Pineapple Upside down Cake.
 16. Never place anything directly on the bottom of the oven cavity. This obstructs the airflow and will cause uneven results.
 17. Never operate the oven if any of the exterior covers are removed. These covers are necessary for protection against exposure to live electrical parts and should only be removed when the oven is being serviced by a qualified service personnel.
 18. This is a commercial cooking oven not intended for non commercial cooking installations or non food products.
 19. Use appropriate food pans and trays for ovens.
 20. Use oven mitts when adding or removing trays/pans from oven when oven is operational.
 21. Use care when removing product from the oven to prevent spills which could cause serious injury to bare skin and eyes. Higher rack levels on ovens are at eye level.
 22. Exterior oven exteriors will become hot during operation caution should be observed.
 23. Proper weight handling and distribution of product in tray or pan will prevent sudden shifts in product to avoid spills and injury.
 24. Do not operate ovens blower fan guard has been removed.
 25. Oven operation sound pressure level should not exceed 70 dB(A).
- Note: Moisture will escape around the doors when baking products with heavy moisture content, such as chicken, potatoes, etc. This is normal.



PROBLEM/SOLUTIONS

Problem	Solution
Cakes are dark on the sides and not done in the center	Lower oven temperature
Cakes edges are too brown	Reduce number of pans or lower oven temperature
Cakes have light outer color	Raise temperature
Cake settles slightly in the center	Bake longer or raise oven temperature slightly. Do not open doors too often or for long periods
Cake ripples	Overloading pans or batter is too thin
Cakes are too coarse	Lower oven Temperature
Pies have uneven color	Reduce number of pies per rack or eliminate use of bake pans
Cupcakes crack on top	Lower oven temperature
Meats are browned and not done in center	Lower temperature and roast longer.
Meats are well done and browned	Reduce time. Limit amount of moisture
Meats develop hard crust	Reduce temperature or place pan of water in oven.
Rolls have uneven color	Reduce number or size of pans.

COOK AND HOLD

Please refer to the operating instructions for cook and hold feature. The times and temperatures listed below are to be used as a starting guide. Your actual results may vary greatly depending on your elevation, gas supply, atmospheric conditions and other items being cooked at the same time.

Weight in lbs	Time in Hours					
	Temperature: 200°F		Temperature: 250°F		Temperature: 300°F	
	Rare	Medium	Rare	Medium	Rare	Medium
8	2.5	3.5	1.5	2	1.25	1.5
9	2.75	3.75	1.75	2.25	1.25	1.75
10	3	4.25	2	2.5	1.5	1.75
11	3.25	4.5	2	2.75	1.5	1.75
12	3.5	5	2.25	3	1.5	2
13	3.75	5	2.5	3.25	1.5	2.25
14	4	5.75	2.5	3.5	1.75	2.5
15	4.25	6	2.75	3.5	2	2.5
16	4.5	6.25	2.75	3.75	2	2.75
17	4.75	6.5	3	4	2.25	2.75
18	4.75	6.75	3.25	4.25	2.25	3
19	5	7.25	3.25	4.25	2.25	3
20	5.25	7.5	3.5	4.5	2.5	3.25
21	5.5	7.75	3.5	4.75	2.75	3.5
22	5.75	7.75	3.5	4.75	2.75	3.5
23	6	8.25	3.75	5	2.75	3.75
24	6	8.75	3.75	5	2.75	3.75
25	6.25	9	4.25	5.5	3	4
26	6.5	9.25	4.25	5.5	3.25	4.25
27	6.75	9.5	4.25	5.75	3.25	4.25
28	7	9.75	4.5	6	3.25	4.25
29	7.25	10	4.75	6.25	3.5	4.5
30	7.25	10.25	4.75	6.25	3.5	4.5



CLEANING AND MAINTENANCE

NOTE: Disconnect line cord from power supply before cleaning or servicing.

Break-In Period

When oven is new, operate it for one hour at 375°F (191°C) before you begin your normal cooking operation. After cooling, wipe the interior, including the racks, with a clean damp cloth.

Exterior Cleaning

Establish a regular schedule. Any spills should be wiped off immediately.

1. The oven should always be allowed to cool sufficiently before any cleaning is attempted.
2. Wipe exposed, cleanable surface when cool with a mild detergent and hot water. Stubborn residue spots may be removed with a lightweight non-metallic scouring pad. Dry thoroughly with a clean cloth.
3. Stubborn stains may be removed by using a non-metallic abrasive pad, rubbing in the direction of the metal's grain. If necessary, for particularly heavy deposits, you may mix a thin paste of water and scouring powder, and apply it with a sponge. Be careful to apply light pressure and remember to rub only in the direction of the grain in the metal.
4. The control panel surface is easily cleaned with hot water, soap and a soft cloth. Do not use hard abrasives, solvent type materials or metallic scouring pads since these will scratch or cloud the surface.
5. Never spray the perforated areas of the control panel with steam or water jets, as this allow moisture into the control cavity. Moisture could damage the electrical components or place the operator at risk of electrical shock.

Interior Cleaning

Establish a regular cleaning schedule or wipe off on the same day when spillovers occur.

1. Cool down oven.
2. Remove oven racks.
3. Lift rack guides on either side of oven off of holders. Racks and guides may be run through dishwasher while oven cavity is being cleaned.
4. Clean with soap and water using a non-metallic scouring pad, if necessary. If dirt and grease have accumulated, a

mild ammonia solution or commercial oven cleaner such as Easy-Off or Dow may be used.

5. To reinstall, reverse procedure. Place the bottom of the rack guide against the cavity wall. Keeping the top pulled away from the wall lift up. Push the top of the guide against the wall and push down locking it into place.

Fan Area Maintenance

If aluminum foil is routinely used to wrap food or cooking vessels during oven operation, the following preventive maintenance must be performed:

1. Turn power switch to "Off" position
2. Remove oven racks and rack guides.
3. Remove air baffle and clean any stains or deposits.
4. Check blower wheel and air baffle for particles of aluminum foil or food deposits. Clean fins of blower wheel. (CAUTION: edges of blower wheel fins may be sharp).
5. Reinstall the air baffle, rack guides and oven racks.

This simple practice, if performed on a regular basis will keep your Garland oven operating at peak performance.

Motor Care

The motor on your convection oven is maintenance free since it is constructed with self-lubricating sealed ball bearings. It is designed to provide durable service when treated with ordinary care. We have a few suggestions to follow on the care of your motor. When the motor is operating, it cools itself internally by air entering at the rear of the motor case, provided proper clearance has been allowed.

Since the blower wheel is in the oven cavity it is at the same temperature as the oven. If the motor is stopped while the oven is hot, the heat from the blower wheel is conducted down the shaft and into the armature of the motor. This action could shorten the life of the motor.

We recommend, at the end of the bake or roasting period, when the oven will be idle for any period of time, or before shutting down completely, that the doors be left open slightly to initiate **cool down**. On digital "M" models, the fan will continue to run until the oven cools down to 150°F (66°C). On the 200 series controllers, push the rocker switch to cool position. Once cool set the rocker switch to OFF. NOTE: Optimal cool-down will be achieved with the door open slightly.

**WELBILT®**
Bringing innovation to the table

Welbilt offers fully-integrated kitchen systems and our products are backed by KitchenCare® aftermarket parts and service. Welbilt's portfolio of award-winning brands includes Cleveland™, Convothem®, Crem®, Delfield®, fitkitchen®, Frymaster®, Garland®, Kolpak®, Lincoln®, Manitowoc®, Merco®, Merrychef® and Multiplex®.

Bringing innovation to the table • welbilt.com