

Owner's Manual

POWERTEC

Dust Collector

? QUESTION...
1-847-780-6120

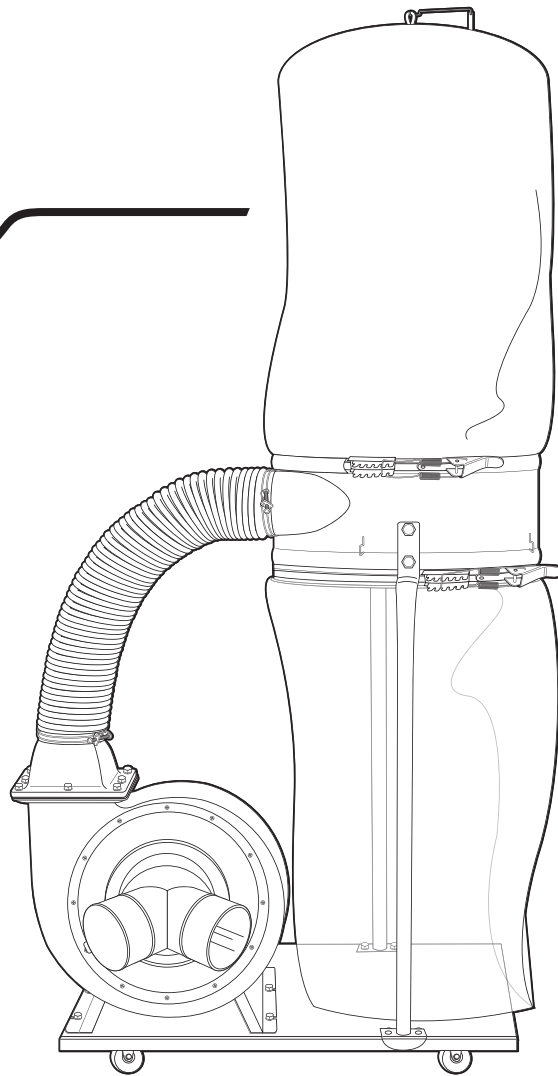







Visit us on the web at www.southerntechllc.com



You will need this manual for safety instructions, operating procedures, and warranty. Put it and the original sales invoice in a safe, dry place for future reference.

TABLE OF CONTENTS

| SECTION | PAGE |
|---------------------------------------------------------------------------------------------------------------------------------------------------------------------------------------------------------------------------------------------------------------------------------------------------------------------------------|-----------|
|  SAFETY RULES <ul style="list-style-type: none"> Work Preparation Work Area Preparation Tool Maintenance Tool Operation Specific Safety Instructions | 1 |
|  ASSEMBLY <ul style="list-style-type: none"> Unpacking Installation Test Power Source Grounding Instructions Extension Cords Motor Electrical Connections | 2 |
|  OPERATION <ul style="list-style-type: none"> Basic Operations | 7 |
|  MAINTENANCE <ul style="list-style-type: none"> General Maintenance Cleaning Lubrication Machine Storage Tool Repairs | 11 |
|  TROUBLESHOOTING | 12 |
|  WARRANTY | 13 |
|  PARTS ILLUSTRATION & LIST | 14 |

PRODUCT SPECIFICATIONS

| | |
|------------------------------|-------------------|
| Horsepower..... | 1.5 HP |
| Voltage | 120/240V |
| Hertz | 60 Hz |
| Phase | 1 |
| Motor Speed | 3450 RPM |
| Air Capacity..... | 1550 CFM |
| Max. Static Pressure..... | 9" |
| Main Inlet Size..... | 4" (101.6 mm) x 2 |
| Impeller Type | Radial Fin |
| Impeller Size | 12 3/4"(324 mm) |
| Collection Bags | |
| Upper bag (filter) | 2.5 micron |
| Lower bag(collection)..... | plastic |
| Bag Overall Dimensions | 19-1/2" x 33" |
| Weight | 106 lbs (48 kgs) |

NOISE DATA

| | |
|-----------------------------------------------------|------|
| a weighted sound pressure level measuring (no load) | |
| Operators position..... | 85dB |
| a weighted sound pressure level measuring (loaded) | 87dB |

SAFETY RULES



1

WARNING

For your own safety, read and understand all warnings and operating instructions before using any tool or equipment.

WARNING

Some dust created by power sanding, sawing, grinding, drilling and other construction activities contains chemicals known to the State of California to cause cancer, birth defects or other reproductive harm.

Some examples of these chemicals are:

- Lead from lead-based paints.
- Crystalline silica from bricks and cement and other masonry products.
- Arsenic and chromium from chemically-treated lumber.

Your risk from these exposures varies, depending on how often you do this type of work. To reduce your exposure to these chemicals: work in a well ventilated area and work with approved safety equipment. Always wear OSHA/NIOSH approved, properly fitting face mask or respirator when using such tools.

WARNING

Always follow proper operating procedures as defined in this manual even if you are familiar with the use of this or similar tools. Remember that being careless for even a fraction of a second can result in severe personal injury.

WORK PREPARATION

- Wear proper apparel. Do not wear loose clothing, gloves, neckties, rings, bracelets or other jewelry which may get caught in moving parts of the tool.
- Wear protective hair covering to contain long hair.
- Wear safety shoes with non-slip soles.
- Wear safety glasses complying with United States ANSI Z87.1. Everyday glasses have only impact resistant lenses. They are NOT safety glasses.
- Wear face mask or dust mask if operation is dusty.
- Be alert and think clearly. Never operate power tools when tired, intoxicated or when taking medications that cause drowsiness.

WORK AREA PREPARATION

- Keep work area clean. Cluttered work areas invite accidents.
- Do not use power tools in dangerous environments. Do not use power tools in damp or wet locations. Do not expose power tools to rain.
- Work area should be properly lit.
- Ground all tools. Proper electrical receptacle should

be available for tool. Three-prong plug should be plugged directly into properly grounded, three-prong receptacle. If an adapter is used to accommodate a two-prong receptacle, the adapter lug MUST be to a known ground.

- Extension cords should have a grounding prong and the three wires of the extension cord should be of the correct gauge.
- Keep visitors at a safe distance from work area.
- Keep children out of the work area. Ensure your work shop is child-proof. Use padlocks, master switches or remove switch keys to prevent any unintentional use of power tools.

TOOL MAINTENANCE

- Always unplug tool prior to inspection.
- Consult manual for specific maintaining and adjusting procedures.
- Keep tool lubricated and clean for a safe operation.
- Remove adjusting tools. Form habit of checking to see adjusting tools or accessories are removed before switching tool on.
- Keep all parts in working order. Check to determine that guard or other parts will operate properly and perform their intended function.
- Check for damaged parts. Check for alignment of moving parts, binding, breakage, mounting and any other condition that may affect tool's operation.
- A guard or any other part that is damaged should be properly repaired or replaced. Do not perform makeshift repairs.

TOOL OPERATION

- Use the right tool for your job. Do not force your tool or attachment to do a job for which it was not designed.
- Avoid accidental start-up. Make sure that the tool is in the "OFF" position before plugging in.
- Never leave tool running unattended.
- Know your tool. Learn the tool's operation, application and specific limitations before using it.

CAUTION

Think safety! Safety is a combination of operator common sense and alertness at all times when tool is being used.

WARNING

Do not attempt to operate tool until it is completely assembled according to the instructions.

SAVE ALL WARNINGS AND INSTRUCTIONS FOR FUTURE REFERENCE



1

SPECIFIC SAFETY INSTRUCTIONS

⚠ WARNING

Read and understand the instruction manual before operating the dust collector. Basic precautions listed below should always be followed when using your dust collector to reduce the risk of injury, electrical shock or fire.

- This dust collector is designed to collect sawdust only.
- Never attempt to use this dust collector to collect water or any other liquids.
- Never try to use this dust collector to collect large wood pieces.
- Never attempt to use this dust collector to collect metal materials such as screws, nails or other metal parts.
- Never attempt to use this dust collector to collect flammable or combustible dust/gas. DO NOT use near any flammable or combustible liquids.
- Never attempt to use this dust collector to collect anything that is burning or smoking.
- DO NOT use outdoors or on wet surfaces.
- Turn machine off, disconnect power cord and ensure all moving parts have stopped completely before servicing or changing/emptying the bags.

- Always wear approved eye protection and respirator when emptying collection/filter bags.
- Ensure the machine is turned off before unplugging the dust collector.
- Unplug dust collector when not in use.
- Grasp the plug not the cord to unplug the dust collector.
- Never pull the dust collector by the power cord.
- Keep vacuum hoses and electrical cord out of traffic areas.
- ALWAYS ensure collection/filter bags are secured in place.
- Do not place your hand or tools near the open inlet while operating. Serious personal injury or damage to the machine can happen.
- Always connect dust collector to the matched power source.
- Place unit on stable, level surface.
- Never operate the dust collector with all blast gates closed.

IMPORTANT : Always consider safety first as it applies to your individual working conditions, the environment in every shop is different.

SAVE ALL WARNINGS AND INSTRUCTIONS FOR FUTURE REFERENCE

ASSEMBLY

UNPACKING

Refer to Figure 1.

Check for shipping damage. Check immediately whether all parts and accessories are included. If anything is missing or broken, contact your retailer or call **847-780-6120**.

- Carefully remove all contents from shipping carton. The shipping carton contains:

| ITEM | DESCRIPTION | QUANTITY |
|------|-----------------------------|----------|
| A | Flexible Hose 5" | 1 |
| B | Collector Support Frame | 1 |
| C | Main Frame Housing | 1 |
| D | Base Plate | 2 |
| E | Upper Bag Support Rod | 1 |
| F | Collector Frame Support Rod | 2 |
| G | Inlet Connector, Dual | 1 |
| H | Filler Bag (Logo) | 1 |
| I | Collection Bag (Plastic) | 1 |
| J | Hose Clamp, 5" | 2 |
| K | Bag Clamps | 2 |
| L | Outlet Gasket | 1 |
| M | Outlet Flange | 1 |

Parts Bag Containing

| | | |
|---|--------------------------------------------------------------|----|
| N | Hex Head Bolt 5/16-18" x 1/2" | 36 |
| O | Pan Flange Head Screw 3/16" - 24 x 3/8" | 1 |
| P | Open End Wrench 10-12 mm | 1 |
| Q | Hex Wrench 5 mm (to be used to remove/replace impeller only) | 2 |
| R | Casters | 4 |
| S | Foam Strip | 1 |
| | Owner's Manual (not shown) | |

Figure 1

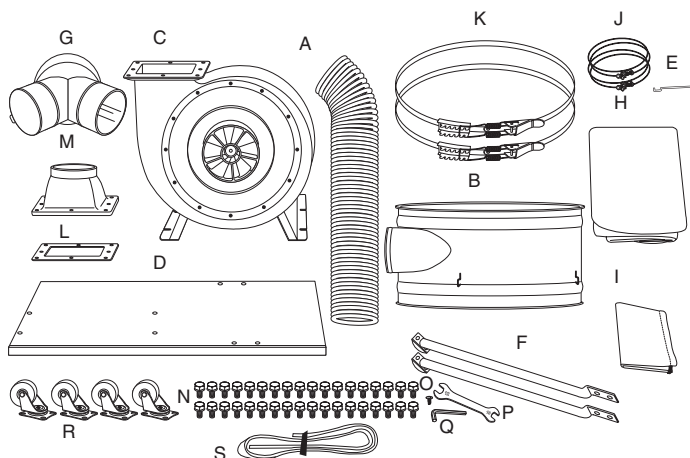

INSTALLATION

Refer to Figures 2 - 12

CAUTION

Do not attempt assembly if parts are missing. Call the Customer service line to obtain replacement parts.

WARNING

Do not operate dust collector until completely assembled. Do not operate this tool until you have completely read and understood this manual.

NOTE: After unit is assembled dispose of all packaging material in an environmentally safe way.

Tools required for assembly:

- 10-12 mm Open End Wrench
- Flat Head Screwdriver

WARNING

Ensure the dust collector is unplugged before assembling.

1. Turn the base plate upside down as shown and attach the four casters using 16 hex head bolts. Tighten with 12 mm wrench.

Figure 2

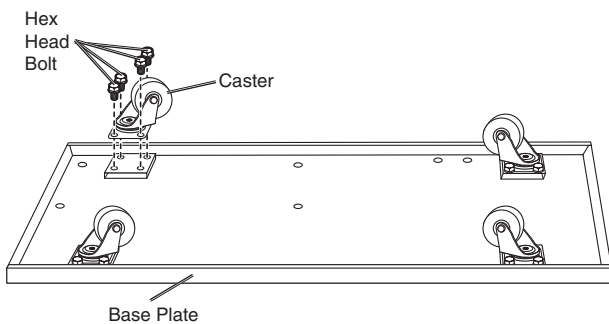

2. Turn the base plate right side up and locate the four threaded holes for the main frame housing.

Figure 3

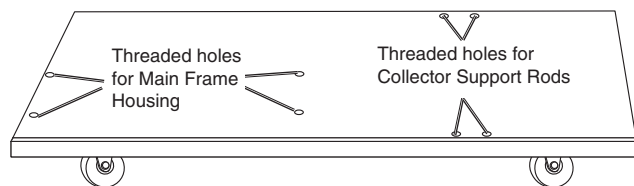

3. Align the main frame housing with the four threaded holes in the base plate, use four hex head bolts to secure and tighten with 12 mm wrench.

Figure 4

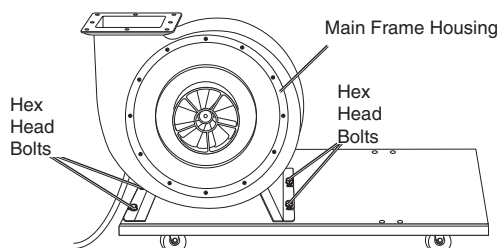

4. Place the two collector support rods on the base plate as shown and use four hex head bolts to secure, tighten with 12 mm wrench.

NOTE: Make sure the rods are assembled with the bend out.

Figure 5

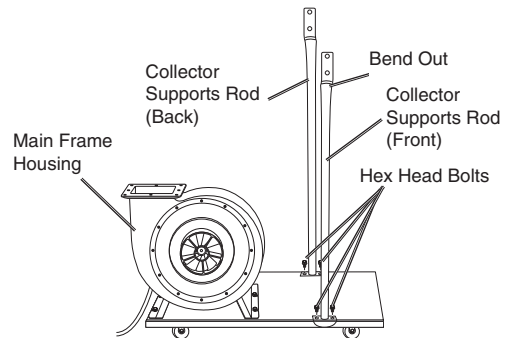

5. Orient the inlet flange of the collector support frame to face the main housing outlet funnel, attach the collector frame support rod on the front of the machine to the collector support frame. Use two hex head bolts to secure, tighten with 12 mm wrench.

Figure 6

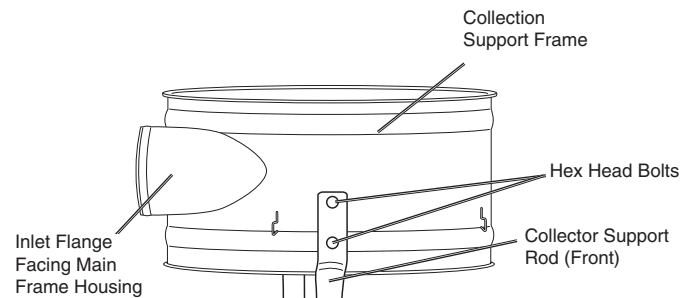

6. Hold the back of the collection support frame and slide the upper support rod between the collector support rod and collector support rod (back). Secure with two hex head bolts, tighten bolts with 12 mm wrench.

Figure 7

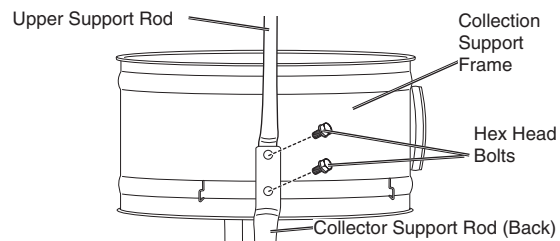

7. Place the gasket onto the top of the opening in the main frame housing.
8. Place the adapter on top of the gasket and use eight hex head bolts to secure. Tighten bolts with 12 mm wrench.

Figure 8

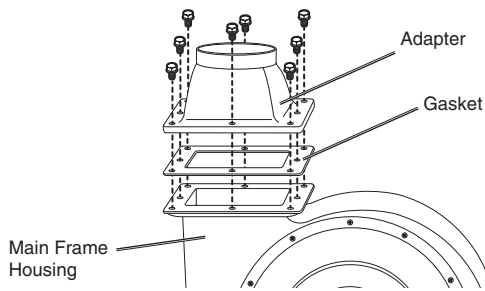

- 4 9. Place the hose clamps on each end of the 5" flexible hose. Place one end over the adapter on the main frame housing and the other end on the outlet on the collector support frame. Tighten screws on the hose clamps to secure in place.

Figure 9

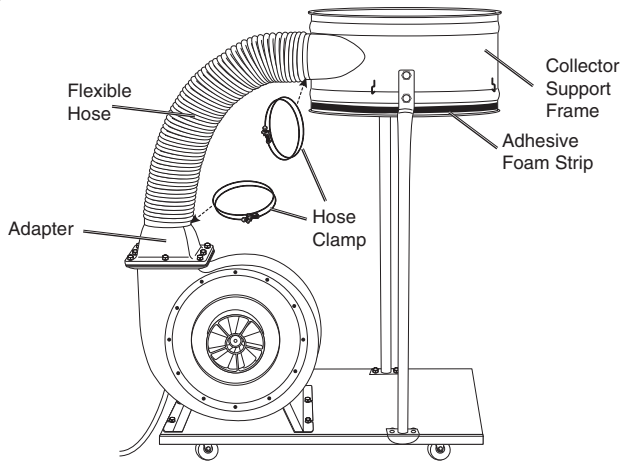

10. Use the pan head screw to attach the dual inlet to the 6" opening of the main frame housing. Tighten with phillips head screw driver.

Figure 10

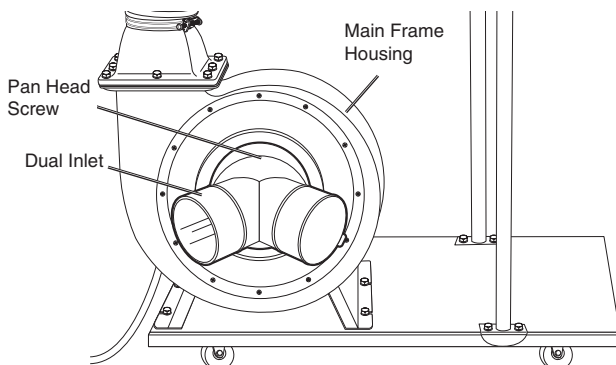

11. Thread a bag clamp through the hemmed opening in the filter bag.

Figure 11

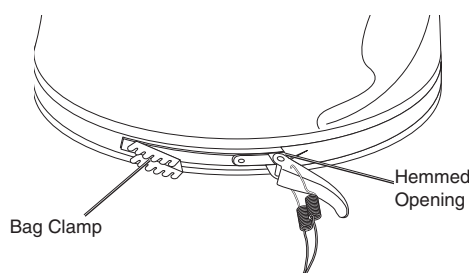

12. Place the filter bag over the top of the collector support frame and hook the top loop over the hook on upper collection support rod. Secure the filter bag in place by fastening the bag clamp.
13. Place the adhesive foam strip (supplied) around the bottom of the dust collector support frame (Figure 9).
14. Place the plastic collection bag over the bottom of the collector support frame and secure in place with the second bag clamp.

Figure 12

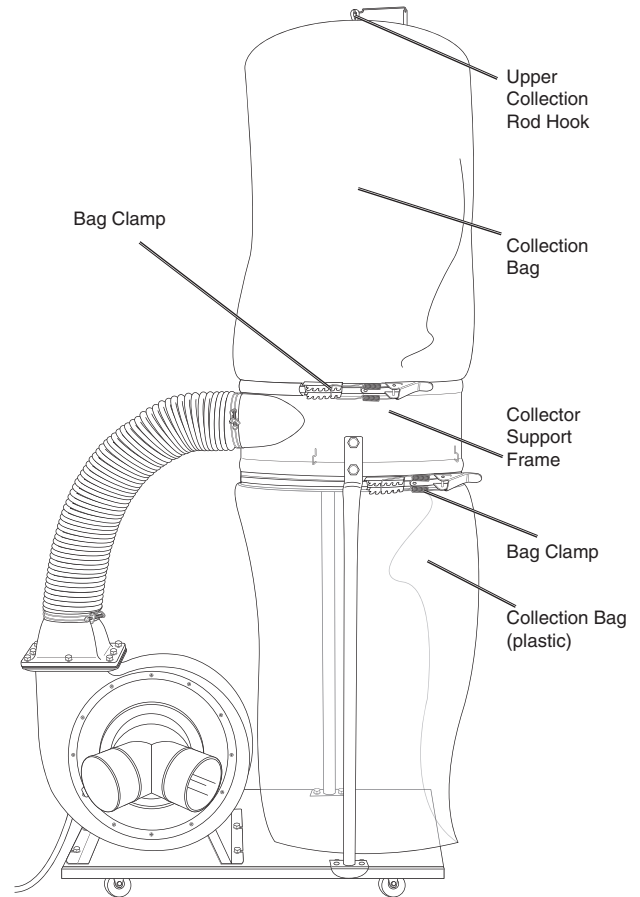

TEST

⚠ WARNING

Before starting the dust collector, make sure you have read and understood the manual and you are familiar with the functions and safety features on the machine. Failure to do so may cause serious personal injury.

Run a test to ensure the dust collector operates properly and the safety key works properly.

1. Ensure all tools used for assembly are removed from the work area.
2. Plug the power cord into the correct receptacle. (Refer to **Power Source** paragraph in this section of the manual.)
3. Turn the dust collector ON. (Refer to **On/Off Switch** paragraph in **Operation** section of the manual.)

4. If unusual noise or excessive vibration is noticed, shut off the machine immediately and disconnect the cord from the power source. Check all the assembled parts once again and investigate to find the problem.
5. If the dust collector operates correctly, turn the machine OFF and remove the safety key on the switch. Once the safety key is removed, turn the switch ON. The machine should not run with the safety key removed.

If everything operates correctly the dust collector is ready for use.

POWER SOURCE

WARNING

Do not connect dust collector to the power source until all assembly steps have been completed.

The motor is designed for operation on the voltage and frequency specified. Normal loads will be handled safely on voltages not more than 10% above or below specified voltage. Running the unit on voltages which are not within the range may cause overheating and motor burn-out. Heavy loads require that the voltage at motor terminals be no less than the voltage specified on nameplate.

- Power supply to the motor is controlled by a single pole locking rocker switch. Remove the key to prevent unauthorized use.
- The motor is prewired to operate on a 120V power supply circuit. The motor can be converted to operate on a 240 power supply. See **To Convert to 240 Power Supply** for instructions.

GROUNDING INSTRUCTIONS

WARNING

Improper connection of equipment grounding conductor can result in the risk of electrical shock. Equipment should be grounded while in use to protect operator from electrical shock.

- Check with a qualified electrician if you do not understand grounding instructions or if you are in doubt as to whether the tool is properly grounded.
- This tool is equipped with an approved cord rated at 120V and a 3-prong grounding type plug (see Figure 13) for your protection against shock hazards.

Figure 13

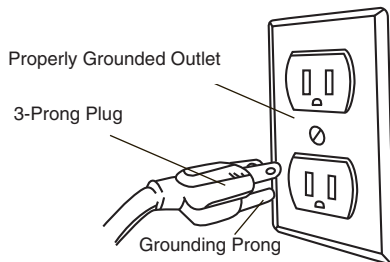

Grounding plug should be plugged directly into a properly installed and grounded 3-prong grounding type receptacle, as shown (see Figure 13).

- Do not remove or alter grounding prong in any manner. In the event of a malfunction or breakdown, grounding provides a path of least resistance for electrical shock.

WARNING

Do not allow fingers to touch the terminals of plug when installing or removing from outlet.

- Plug must be plugged into matching outlet that is properly installed and grounded in accordance with all local codes and ordinances. Do not modify plug provided. If it will not fit in outlet, have proper outlet installed by a qualified electrician.
- Inspect tool cords periodically, and if damaged, have repaired by an authorized service facility.
- Green (or green and yellow) conductor in cord is the grounding wire. If repair or replacement of the electric cord or plug is necessary, do not connect the green (or green and yellow) wire to a live terminal.

EXTENSION CORDS

- The use of an extension cord is not recommended. The use of any extension cord will cause some drop in voltage and loss of power.
- Wires of the extension cord must be of sufficient size to carry the current and maintain adequate voltage.
- Use the table to determine the minimum wire size (A.W.G.) extension cord.
- Use only 3-wire extension cords having 3-prong grounding type plugs and 3-pole receptacles which accept the tool plug.
- If the extension cord is worn, cut or damaged in any way, replace it immediately.
- Extension Cord Length

| | |
|-----------------------|----------|
| Wire Size | A.W.G. |
| Up to 50 ft | 14 gauge |

NOTE: Using extension cords over 50 ft. long is not recommended.

MOTOR

The dust collector is assembled with motor and wiring installed. The electrical wiring schematic is shown in Figure 14.

The permanently split capacitor motor has the following specifications:

| | |
|--------------------------------|---------|
| Horsepower (Peak HP) | 1.5 |
| Voltage | 120/240 |
| Amp | 18/9 |
| Hertz | 60 |
| Phase | Single |
| RPM | 3450 |

NOTE: These circuit requirements apply to a dedicated circuit, where only one machine will be running at a time. If this machine is connected to a shared circuit with multiple machines running at the same time, consult with a qualified electrician to ensure the circuit is properly sized for safe operation.



ELECTRICAL CONNECTIONS



All electrical connections must be performed by a qualified electrician. Make sure tool is off and disconnected from power source while motor is mounted, connected, reconnected or anytime wiring is inspected. Motor and wires are installed as shown in wiring schematic (See Figure 14). Motor is assembled with approved, 3-conductor cord to be used at 120 volts.

The power lines are inserted directly into the switch. The green ground line must remain securely fastened to the frame to properly protect against electrical shock. The power supply to the motor is controlled by a single pole locking rocker switch.

- Remove the key to prevent unauthorized use.

TO CONVERT TO 240V POWER SUPPLY

To convert the dust collector to 240V the switch box must be rewired and a new plug attached. A qualified electrician **MUST** inspect the switch box and new plug before the dust collector is connected to the power source.

The 240V power supply circuit must have a verified ground and meet these requirements:

- Circuit Type 240V/240V, 60 Hz, Single Phase
- Circuit Size 15 Amps
- Plug Receptacle NEMA 6-15

TO CONVERT

1. Make sure the tool is unplugged.
2. Open the switch box cover.
3. Follow the 240V wiring diagram on the inside of the switch box cover. **NOTE:** The 240V wiring diagram is also in Figure 14. Call the customer service line at **847-780-6120** for assistance if needed.
4. After rewiring make sure all wire nuts are tight and use electrical tape to secure them in place.
5. Replace the plug on the existing power cord with a NEMA 6-15 plug. The plug must be plugged into matching outlet that is properly installed and grounded in accordance with all local codes and ordinances.
6. Have the wiring inspected by a qualified electrician.
7. Replace the switch box cover.

Figure 14

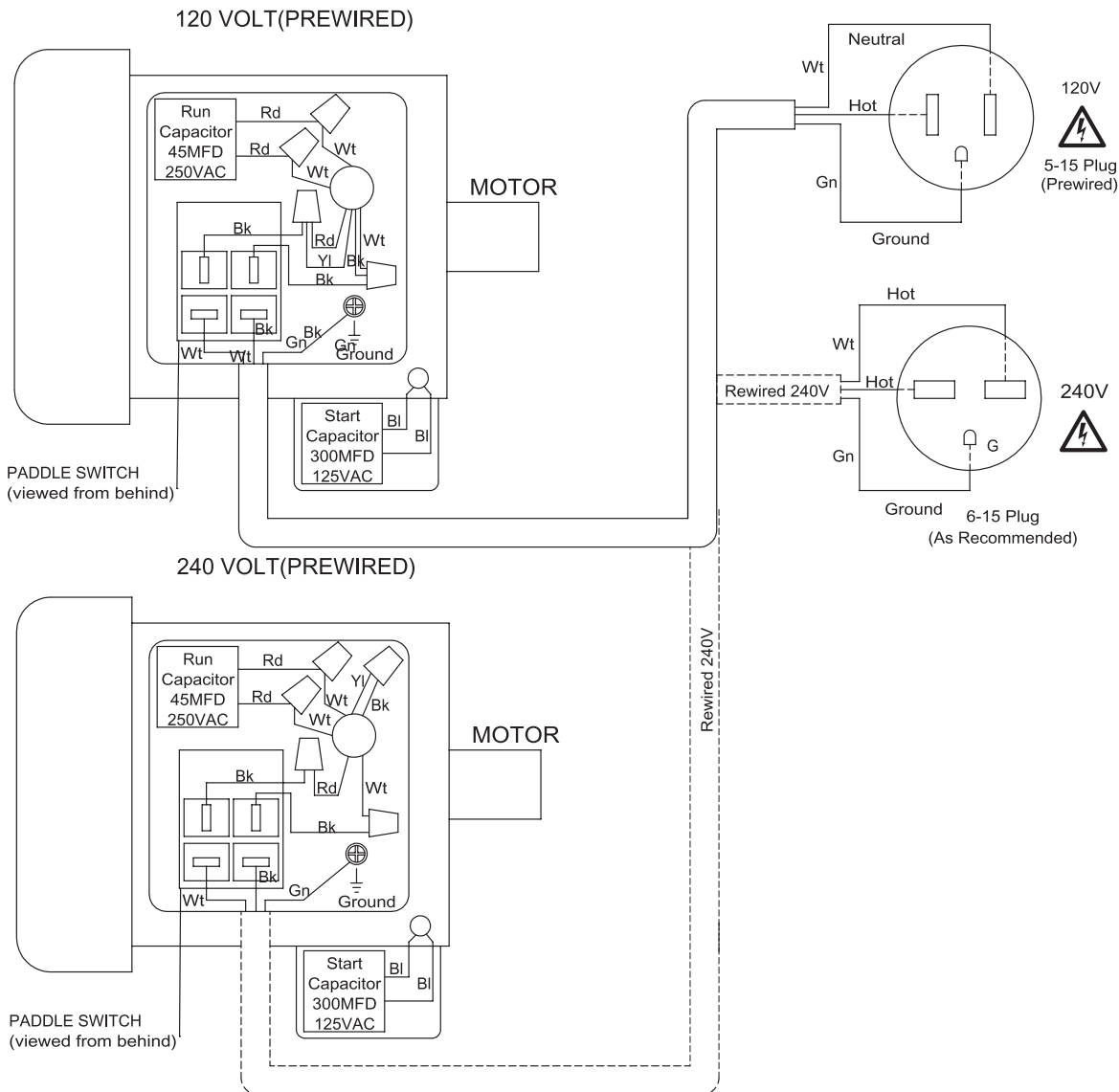

BASIC OPERATIONS

ON/OFF Switch

The keyed switch is intended to prevent unauthorized use of the dust collector.

1. To turn the dust collector ON insert the yellow key into the key slot in the center of the switch.
2. Push the key firmly into the slot, then push switch to the ON position to start the dust collector.
3. To turn the dust collector OFF push the switch to the down position.
4. Remove the yellow switch key, when the dust collector has come to a complete stop, by gently pulling it outward.

WARNING

Remove the switch key whenever the dust collector is not in use.

Place it in a safe place and out of reach of children.

WARNING

ALWAYS lock the switch OFF when the dust collector is not in use. Remove the key and keep it in a safe place. In the event of power failure, blown fuse, or tripped circuit breaker, turn the switch OFF and remove the key, preventing accidental startup when power comes on.

Figure 15

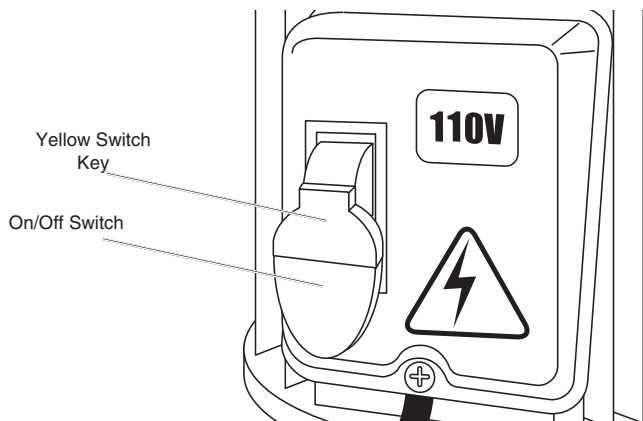

Operation

WARNING

ALWAYS guard against static electric build-up by grounding all dust collection lines.

NOTE: This dust collector is designed to be a stationary unit connected to a shop dust collection system or a mobile unit.

NOTE: Only open blast gates being used if connected to a shop dust collection system

1. **For stationary usage**, locate the dust collector out of the way in a corner or separate room. Connect the dust collector to a shop dust collection system (not included). Follow all instructions included with the shop dust collection system. See **Shop Dust Collection System Set-up** section for more information.
For mobile usage, position the dust collector close to the tools being used. Connect collector hoses (not included) to the dust collector dual inlet, connect the other end of the hoses to the machine outlets. Secure both ends of the hose with hose clamps (not included). **NOTE:** If only connecting to one machine the second inlet, close the cap on the second collector dual inlet.
2. This dust collector is designed to collect dust from up to two machines running at the same time.
3. Turn the dust collector ON. (Refer to **On/Off Switch** paragraph in this section of the manual.)

Figure 16

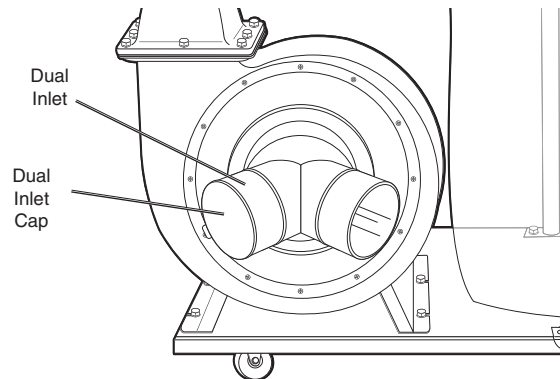

SHOP DUST COLLECTION SYSTEM SET-UP

NOTE: The following information is provided as a basic guideline to help plan and setup your dust collection system. To complete and fine tune the design of your system several books and web based information is available. Simply search for **Dust collection system design** or **Dust Collection Basics**.

WARNING

ALWAYS guard against static electric build-up by grounding all dust collection lines.

WARNING

RISK OF EXPLOSION. ALWAYS make sure there are no open flames or pilot lights in the same room as the dust collector.

Choose the duct material

For best results, use metal duct for the main line and branch lines, then use short lengths of flexible hose to connect each machine to the branch lines.

To prevent fire or explosion hazard when using plastic duct material the system will need to be grounded against static electrical charge build-up. See the **Grounding the Shop Dust Collection System** section.

Metal Duct

- Metal duct is conductive, efficient and does not contribute to static electrical charge build-up. However, static charges are still produced when dust particles strike other dust particles as they move through the duct. Since metal duct is a conductor, it can be grounded quite easily to dissipate any static electrical charges.
- Choose metal duct that is manufactured for dust collection systems. The metal duct should be made of high quality metal duct with smooth welded internal seams to minimize airflow resistance. This type of duct usually connects to other ducts or elbows with self-sealing clamps that make it easy to assemble and disassemble.
- Avoid using metal duct material not manufactured for dust collection systems.

Plastic Duct

- Plastic duct is economical and readily available. It is simple to assemble and easily sealed against air loss. The primary disadvantage of plastic duct for dust collection is the inherent danger of static electrical build-up.

Flexible Duct

- Flexible hose is used for short runs, small shops and duct-to-tool connections. Flexible hoses are available, in different materials such as polyethylene, PVC, cloth hose dipped in rubber and even metal, including steel and aluminum.

- Choose flexible hose designed for the movement of solid particles, i.e. dust, grains, and plastics.
- The recommended flex hose material is metal.
- Non-perforated drainage type hoses and dryer vent hoses are not recommended to be used with a dust collection system.

GROUNDING THE SHOP DUST COLLECTION SYSTEM

WARNING

ALWAYS guard against static electric build-up by grounding all dust collection lines.

Plastic hose is abundant, relatively inexpensive, easily assembled and air tight, making it a popular material to be used in dust collection systems. Flexible hose (flex-hose) is recommended when connecting the woodworking machine to the dust collector. Plastic flex-hose and plastic duct are insulators and **MUST** be grounded. If not grounded the electrical discharge created, from the dust particles moving against the walls of the plastic duct, may cause an explosion and subsequent fire inside the system.

To Ground

To protect against static electrical build up inside a non-conducting duct, a bare copper wire should be placed inside the duct along its length and grounded to the dust collector. You must also confirm that the dust collector is continuously grounded through the electrical circuit to the electric service panel.

- Insert a continuous bare copper ground wire inside the entire duct system and attach the bare ground wire to each stationary woodworking machine and attach it to the dust collector frame with a ground screw (Figure 17).

Figure 17

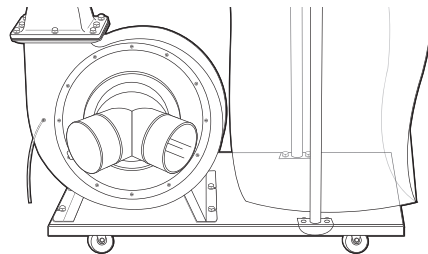

- Extend the bare copper wire down all branches of the system. Make sure all wires are connected to each other with wire nuts when two branches meet at a "Y" or "T" connection (Figure 18).

Figure 18

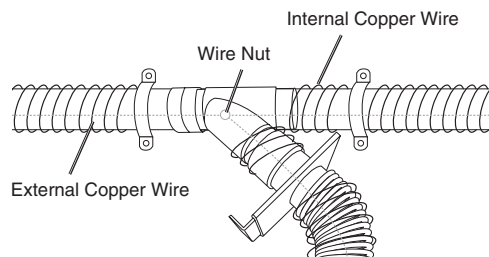

- Wrap the outside of all plastic ducts with bare copper wire to ground the outside of the system against static electrical build up. Make sure all wires are connected to each other with wire nuts when two branches meet at a "Y" or "T" connection (Figure 19).

Figure 19

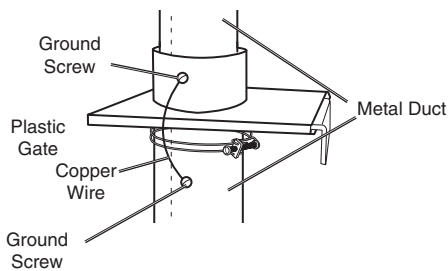

- When plastic blast gates are used the grounding wire must be jumped around the blast gate without interruption to the grounding system.
- Ensure that each machine is properly grounded. Refer to the machine owner's manual for correct procedure.

DUST COLLECTION SYSTEM LAYOUT

Use the following information as a guide to layout a dust collection system for a small to medium shop. More research or the help from an expert will be needed to layout a dust collection system for a large shop.

NOTE: To complete and fine tune the design of your system several books and web based information is available. Simply search for **Dust collection system design** or **Dust Collection Basics**.

1. Sketch the layout of the shop floor. Include each machine and the dust collector.
2. Sketch the layout of the main line ducts and the branch line ducts to connect each machine to the dust collection system.
 - Place the machines that produce the most saw dust nearest to the dust collector
 - The main line and secondary branch ducts should be designed to be as short as possible.
 - Keep direction changes to a minimum. Directional change fittings increase the overall resistance to flow.
 - Used the largest corner radius possible when changing hose or pipe direction, a gradual directional change is more efficient.
 - Each individual branch line should have a blast gate.
3. Determine the required CFM to determine the size of duct work needed.
 - Each machine produces a different amount of sawdust. The minimum amount of CFM needed to move the sawdust is different for each machine.
 - The Table 1 shows the approximate required CFM per machine based on the dust port size. **NOTE:** Place machines that generate the most sawdust close to the dust collector (planers, sanders).

NOTE: If a machine has multiple dust ports the CFM required is the sum of all ports.

TABLE 1

| MACHINE DUST PORT SIZE | APPROXIMATE REQUIRED CFM |
|------------------------|--------------------------|
| 2" | 98 |
| 2.5" | 150 |
| 3" | 220 |
| 4" | 395 |
| 5" | 614 |
| 6" | 884 |
| 7" | 1203 |
| 8" | 1570 |
| 9" | 1990 |
| 10" | 2456 |

- See Table 2 to help determine what size dust port is needed on machines without a built-in dust port.

TABLE 2

| MACHINE | DUST PORT SIZE |
|---------------------------------------|----------------|
| Bandsaw | 4" |
| Belt Sander (6" and smaller) | 2" |
| Belt Sander (7"-9") | 3" |
| Disc Sander (12" and smaller) | 2" |
| Disc Sander (13-18") | 4" |
| Drum Sander (24" and larger) | 4 x 4" |
| Drum Sander (24" and smaller) | 2 x 4" |
| Edge Sander (6" x 80" and larger) | 5" |
| Edge Sander (6" x 80" and smaller) | 4" |
| Jointer (6" and smaller) | 4" |
| Jointer (8"-12") | 5" |
| Lathe | 4" |
| Miter/Radial-Arm Saw | 2" |
| Router (mounted to table) | 2" |
| Shaper | 4" |
| Table Saw | 4" |
| Thickness Planer (13" and smaller) | 4" |
| Thickness Planer (14"-20") | 6" |
| Widebelt Sander (18" and smaller) | 5" |
| Widebelt Sander (24"-37" single head) | 2 x 6" |
| Widebelt Sander (24"-51" double head) | 5 x 4" |

4. Determine the main line duct size.
 - Add the required CFM to your sketch for each machine.
 - The velocity of the airflow must not fall below 3500 CFM.
 - Using the inlet size of the dust collector as the main line duct size will usually keep the air velocity above 3500 CFM.

- Figure 20 gives an example of the CFM for each machine, the dust collector inlet size being used as the main line and the determined branch line size.
5. Determine the branch line duct size.
- The velocity of the airflow must not fall below 4000 CFM.
 - In small to medium size shops make the branch size the size of the machine's dust port size.
 - If the machine's dust port size is smaller than 4" make the branch line 4" and neck the line down at the machine.
 - Add the determined branch line sizes to the sketch,
 - If two machines will share a branch line and both will operate at the same time, add the required CFM for each machine together. See Table 3 and find the closest CFM to determine the branch line size required. If the machines will never run at the same time use the machine with the largest dust port to determine the required branch line size. Add a Y-connector and blast gate to each machine to open/close when needed.

TABLE 3

| TOTAL CFM | BRANCH LINE SIZE |
|-----------|------------------|
| 400 | 4" |
| 500 | 4" |
| 600 | 5" |
| 700 | 5" |
| 800 | 6" |
| 900 | 6" |
| 1000 | 6" |

6. Plan the drop downs for each machine.
- Use blast gates wherever possible to control the air flow (Figure 21).

Figure 21

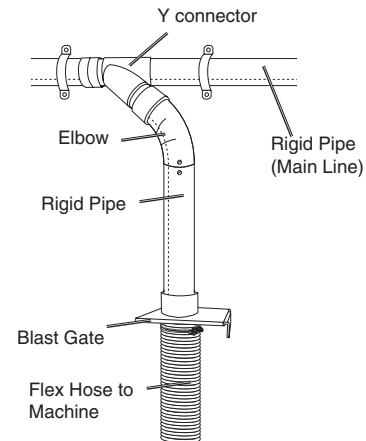
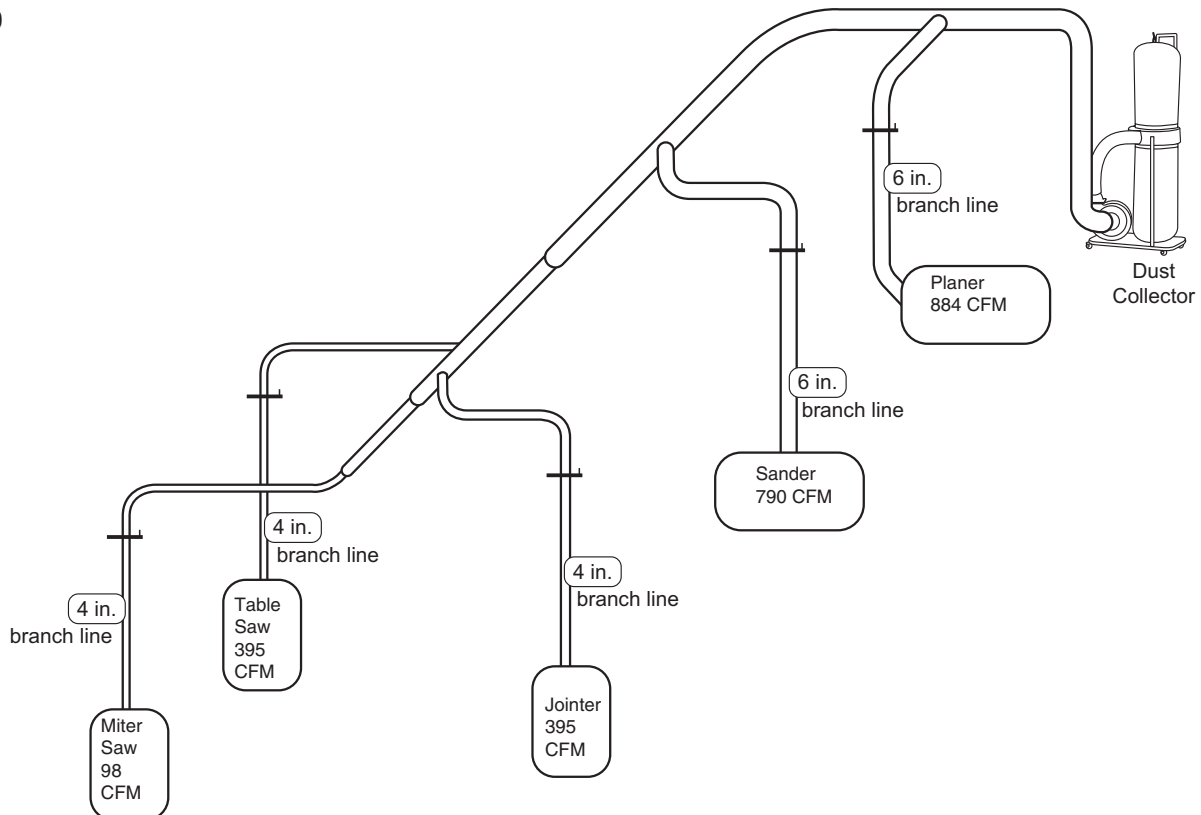

Figure 20





GENERAL MAINTENANCE

WARNING

Make sure the machine is turned off and the cord is disconnected from the power source before servicing and removing/replacing any components on the machine.

- Check the dust collector daily for loose mounting bolts, screws, damaged wires, worn switch, full collection bag and any other unsafe condition.

CLEANING

WARNING

ALWAYS wear a respirator and safety goggles when emptying the collector bags.

Check and empty the collection bag on your dust collector regularly. The machine operates at a much higher level of efficiency when the collection bag is empty.

LUBRICATION

The sealed bearings in the motor have been permanently lubricated at the factory. They require no further lubrication.

MACHINE STORAGE

- When the dust collector is not in use, disconnect the cord from the power source and store the machine in a dry place.
- Do not expose the machine to rain.
- Ensure the cord is kept away from potential damage sources such as; sharp objects, chemicals, heat sources and water.

TOOL REPAIRS

- If power cord is worn, cut, or damaged in any way, have it replaced immediately.
- Replace worn abrasives when needed.
- Replace any damaged or missing parts. Use parts list to order parts. Any attempt to repair motor may create a hazard unless repair is done by a qualified service technician. Call the customer service line at **847-780-6120** for assistance.

12 ?

TROUBLESHOOTING

| SYMPTOM | POSSIBLE CAUSE(S) | CORRECTIVE ACTION |
|-------------------------------------------------------------------------------------------------------------------------------------------------------------------------------|-------------------------------------------------------------------------------------------------------------------------------------------------------------------------------------------------------------------------------------------------------------------------------------------------------------------------------------------------------------------------------------------------------------------------------------------------------|-------------------------------------------------------------------------------------------------------------------------------------------------------------------------------------------------------------------------------------------------------------------------------------------------------------------------------------------------------------------------------------------------------------------------------------------------------------------------------------------------------------------------------------------------------------------------------------|
| Motor will not start | <ol style="list-style-type: none"> 1. Low voltage 2. Open circuit in motor or loose connections 3. Defective switch 4. Defective capacitor 5. Switch key is removed | <ol style="list-style-type: none"> 1. Check power line for proper voltage 2. Inspect all lead connections on motor for loose or open connection 3. Replace switch 4. Replace capacitor 5. Insert switch key |
| Motor will not start; fuses blown or circuit breakers are tripped | <ol style="list-style-type: none"> 1. Short circuit in line cord or plug 2. Short circuit in motor or loose connections 3. Incorrect fuses or circuit breakers in power line | <ol style="list-style-type: none"> 1. Inspect line cord or plug for damaged insulation and shorted wires 2. Inspect all lead connections on motor for loose or shorted terminals or worn insulation on wires 3. Install correct fuses or circuit breakers |
| Unit has vibration or noisy operation | <ol style="list-style-type: none"> 1. Motor or components are loose 2. Motor mount is loose/broken 3. Motor fan is rubbing cover 4. Motor bearings faulty 5. Dust collector is not on a flat surface | <ol style="list-style-type: none"> 1. Inspect/replace any stripped or damaged bolts/nuts and re-tighten. 2. Tighten/replace 3. Replace fan cover; replace loose/damaged fan 4. Call the customer service line at 847-780-6120 for assistance 5. Place the dust collector on a flat surface. |
| <p>Loud, repetitious noise or excessive vibration coming from dust collector</p> <p>OR</p> <p>Dust collector does not adequately collect dust or chips; poor performance.</p> | <ol style="list-style-type: none"> 1. Dust collection bag is full 2. Dust collector hose restricted 3. The lumber is wet and dust is not flowing through the hose smoothly 4. There is a leak in the hose 5. Restriction in duct line. 6. Dust collector is too far away, or there are too many sharp bends in the ducting. 7. The machine dust collection design is inadequate. | <ol style="list-style-type: none"> 1. Empty collection bag. 2. Remove hose from dust collector inlet and unblock the restriction in the hose. A plumbing snake may be necessary. 3. Process lumber with less than 20% moisture content. 4. Inspect and replace hose. 5. Remove restriction in the duct line. A plumbing snake may be necessary. 6. Relocate the dust collector closer to the point of suction and rework ducting without sharp bends. 7. Ensure the correct sized ducts and fittings are used. |
| Sawdust blown into the air from the dust collector | Hose clamps or dust collection bag is not properly clamped and secured. | Check hose and dust collection bag, ensure hose and bag clamps are tight and completely over the hose and bag. |

Thank you for investing in a **POWERTEC** power tool. This product has been designed and manufactured to meet high quality standards and is guaranteed for domestic use against defects in workmanship or material for a period of 12 months from the date of purchase. This guarantee does not affect your statutory rights.

SOUTHERN TECHNOLOGIES LLC. BENCH TOP AND STATIONARY POWER TOOL LIMITED 1 YEAR WARRANTY AND 30-DAY SATISFACTION GUARANTEE POLICY

POWERTEC products are designed and manufactured by **Southern Technologies LLC**. All warranty communications should be directed to **Southern Technologies LLC** by calling 847-780-6120 (toll free), 9 AM to 5 PM, Monday through Friday, US Central Time.



30- DAY SATISFACTION GUARANTEE POLICY

During the first 30 days after the date of purchase, if you are dissatisfied with the performance of this **POWERTEC** tool for any reason, you may return the tool to the retailer from which it was purchased for a full refund or exchange. You must present proof of purchase and return all original equipment packaged with the original product. The replacement tool will be covered by the limited warranty for the balance of the one year warranty period.

LIMITED ONE YEAR WARRANTY

This warranty covers all defects in workmanship or materials in this **POWERTEC** tool for a one year period from the date of purchase. This warranty is specific to this tool. **Southern Technologies, LLC** reserves the right to repair or replace the defective tool, at its discretion.

HOW TO OBTAIN SERVICE

To obtain service for this **POWERTEC** tool you must return it, freight prepaid, to **POWERTEC**. You may call (toll free) 847-780-6120 for more information. When requesting warranty service, you must present the proof of purchase documentation, which includes a date of purchase. **POWERTEC** will either repair or replace any defective part, at our option at no charge to you. The repaired or replacement unit will be covered by the same limited warranty for the balance of one year warranty period.

WHAT IS NOT COVERED

This warranty applies to the original purchaser at retailer and may not be transferred.

This warranty does not cover consumable items such as saw blades, knives, belts, discs, cooling blocks and sleeves. This warranty does not cover required service and part replacement resulting from normal wear and tear, including accessory wear.

This warranty does not cover any malfunction, failure or defect resulting from:

- 1) misuse, abuse, neglect and mishandling not in accordance with the owner's manual.
- 2) damage due to accidents, natural disasters, power outage, or power overload.
- 3) commercial or rental use.
- 4) alteration, modification or repair performed by persons not recommended by **POWERTEC**.

DISCLAIMER

To the extent permitted by applicable law, all implied warranties, including warranties of MERCHANTABILITY or FITNESS FOR A PARTICULAR PURPOSE, are disclaimed. Any implied warranties, that cannot be disclaimed under state law are limited to one year from the date of purchase. **Southern Technologies LLC**. is not responsible for direct, indirect, incidental or consequential damages. Some states do not allow limitations on how long an implied warranty lasts and/or do not allow the exclusion or limitation of incidental or consequential damages, so the above limitations may not apply to you. This warranty gives you specific legal rights, and you may also have other rights which vary from state to state. Southern Technologies LLC., makes no warranties, representations, or promises as to the quality or performance of its power tools other than those specifically stated in this warranty.



DUST COLLECTOR PARTS ILLUSTRATION

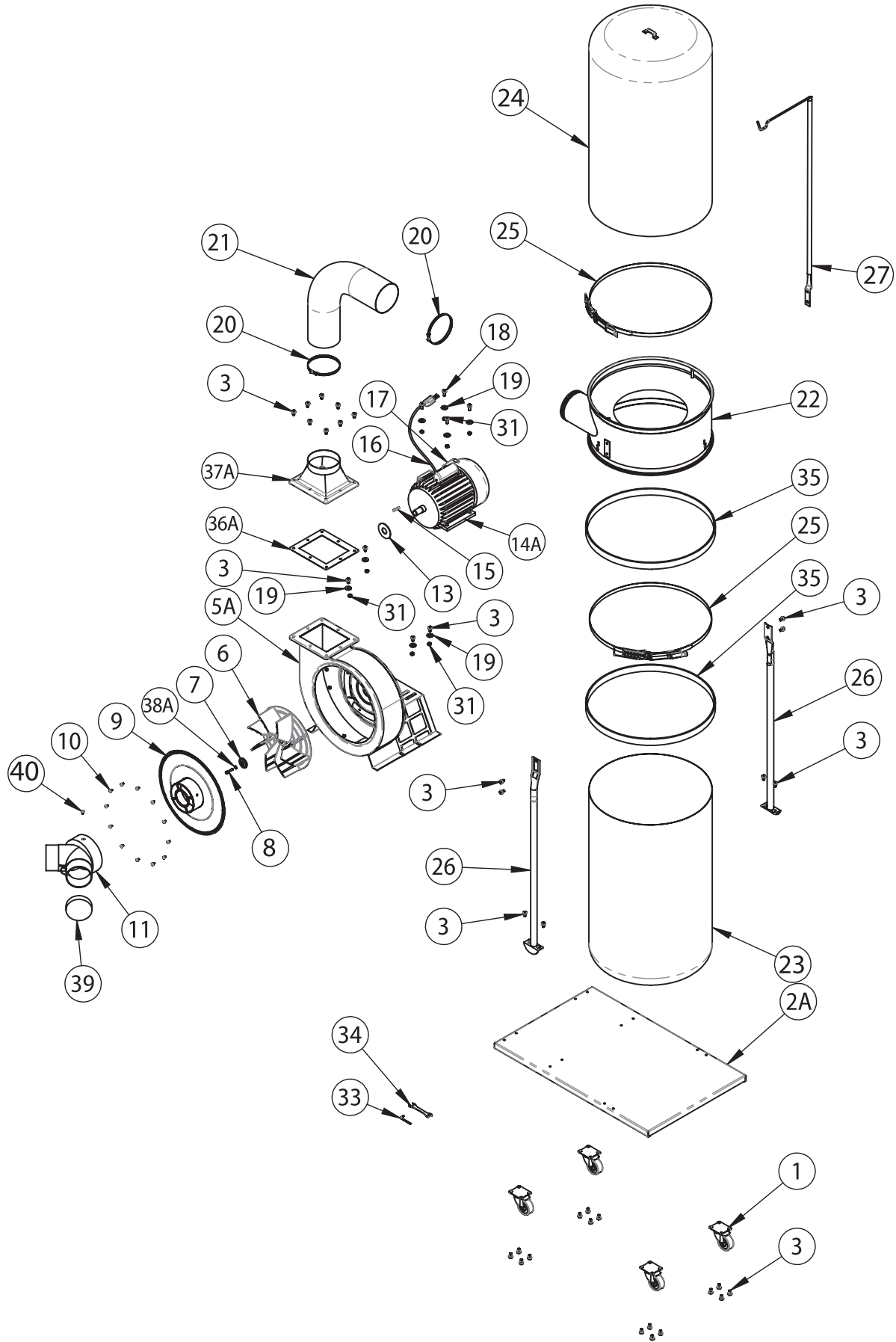

DUST COLLECTOR PARTS LIST



| Item# | Description | Specification | Q'ty | |
|-------|-------------|-----------------------------|------------------|----|
| 1 | DC1512001 | Caster | 4 | |
| 2A | DC1512002 | Base Plate | 1 | |
| 3 | DC1512003 | Screw Hex.flange.head | 5 / 16"- x 1/2" | 38 |
| 5A | DC1512004 | Collector | 1 | |
| 6 | DC1512005 | Turbo Fan | 1 | |
| 7 | DC1512006 | Washer | 1 | |
| 8 | DC1512007 | Cap Screw | M6 x 1.0 x 19 mm | 1 |
| 9 | DC1512008 | Inlet Cover | 1 | |
| 10 | DC1512009 | Screw | 12 | |
| 11 | DC1512010 | Inlet | 1 | |
| 13 | DC1512011 | Anti Vibration Plate | 3 | |
| 14A | DC1512012 | Motor | 1 | |
| 15 | DC1512013 | Pin | 1 | |
| 16 | DC1512014 | Power Cord | 1 | |
| 17 | DC1512015 | Switch | 1 | |
| 18 | DC1512016 | Flange Bolt | 5/16" x 3/4" | 4 |
| 19 | DC1512017 | Washer | 5/16" | 4 |
| 20 | DC1512018 | Hose Clamp.5" Expandable | 2 | |
| 21 | DC1512019 | Hose,5" Expandable | 1 | |
| 22 | DC1512020 | Collector | 1 | |
| 23 | DC1512021 | Bottom Bag | 1 | |
| 24 | DC1512022 | Top Bag With Logo | 1 | |
| 25 | DC1512023 | Belt Clamp | 2 | |
| 26 | DC1512024 | Collector Frame Support Rod | 2 | |
| 27 | DC1512025 | Upper Bag Supporter Rod | 1 | |
| 31 | DC1512026 | Nut | 5/16" | 8 |
| 33 | DC1512027 | Allen Key | 1 | |
| 34 | DC1512028 | Open And Wrench | 10 x 12 mm | 1 |
| 35 | DC1512029 | Foam | 2 | |
| 36A | DC1512030 | Outlet Gasket | 1 | |
| 37A | DC1512031 | Outlet Flange | 1 | |
| 38A | DC1512032 | Screw Hex.sic Head | M6 x 13 | 1 |
| 39 | DC1512033 | Cap | 1 | |
| 40 | DC1512034 | Screw | 1 | |



POWERTEC

Southern Technologies, LLC
3816 Hawthorn CT,
Waukegan, IL 60087