



MODELS

AX-413

to



AX-824RHD

For operator. Do not discard.



Dear client, thank you and congratulations for buying this appliance; we are confident that this is the beginning of a positive and long-lasting collaboration.

This manual has all the necessary information for the correct use, maintenance and installation of this appliance. The objective of this manual is to enable the technician and user to take all measures and precautions necessary for the safe, efficient, long-term use of the appliance. Keep this booklet in a safe place, over the entire life cycle of the product for subsequent reference by the operators designated to use and specialized technicians.

Where documents are lost or damaged, the replacement documentation must be requested directly from the manufacturer or retailer. The manufacturer is not held liable for any damage caused by people, things or for inappropriate use of the appliance, modifications or repairs carried out by unauthorized personnel or used with spare parts not recommended by the manufacturer and not intended for use with this model. This appliance complies with the EEC directives in force. Please refer to the warranty documentation in the booklet.



MVP GROUP CORPORATION
12000 Biscayne Blvd, Suite #108
Miami, FL, United States 33181
Telephone: (786) 600-4687
Toll Free Telephone: 1-844-218-8477
Fax: (786) 661-4100
Email: service@mvpgroupcorp.com

Contents



| | |
|---------|-------------------------------------|
| PAGE 4 | WARRANTY |
| PAGE 5 | CONNECTING YOUR OVEN |
| I | WARNING |
| II | PRELIMINARY OPERATIONS |
| III | INSTALLATION AREA |
| PAGE 6 | |
| IV | PREPARING FOR INSTALLATION |
| V | ELECTRICAL CONNECTIONS |
| PAGE 7 | |
| | CABLE CONNECTION |
| PAGE 8 | |
| | EQUIPOTENTIAL CONNECTION |
| PAGE 9 | |
| VI | WATER CONNECTION |
| VII | VENT CONNECTION |
| VIII | STACKING OVENS |
| PAGE 10 | |
| IX | SERIAL PLATE |
| PAGE 11 | |
| | INSTRUCTION TO USER |
| I | WARNING |
| PAGE 12 | |
| II | USING IT FOR THE FIRST TIME |
| | TESTING |
| PAGE 13 | QUICK GUIDE |
| PAGE 15 | MECHANICAL CONTROLS |
| PAGE 16 | ELECTRONIC CONTROLS |
| PAGE 18 | FIRST TIME CLEANING THE OVEN |
| PAGE 20 | TROUBLESHOOTING |
| PAGE 21 | SCHEDULED MAINTENANCE |
| | CONTACT INFORMATION |



MANUFACTURERS LIMITED WARRANTY

MVP Group Corporation (Axis) hereby warrants all new ovens bearing the name "AXIS" and installed within the continental United States of America or Canada to be free from defects in material or workmanship, under normal and regular usage and operation, for a period of one (1) year following the date of original installation, (unless specified otherwise) but in no event can exceed eighteen (18) months from the date of shipment from the factory.

If a defect in material(s) or workmanship is detected; or found to exist within the stated period above, Axis, at its sole discretion, shall either repair or replace any original equipment manufacturers part which has proven to fail within the machine; providing that the equipment has not been altered or tampered with in any manner, has been installed correctly as per the owner's manual, and maintained and operated in complete accordance with this manual.

The labor cost to repair or replace any part proven to be defective, as per above clause(s), shall be covered by Axis, within the continental United States of America or Canada; provided that: prior authorization for this labor was approved by Axis, the service work was performed by an authorized Axis service agency; and that this agency installed an original and genuine Axis part in the machine. Any repair work performed by a non-authorized service depot remains the sole responsibility of the user, and Axis Systems will not be held responsible. The installation of any generic part will not be valid; and therefore voids this warranty. All authorized labor coverage shall be limited to regular hourly rates only. Any supplemental hourly rates or charges, such as weekends or emergency premiums remain the responsibility of the user.

MVP Group Corp. (Axis) hereby states that: warranty travel time shall be limited to, and without exception, a one-time round-trip total of two (2) hours OR mileage up to a maximum of one hundred (100) miles round-trip. Any charges exceeding those stated herein must have prior authorization by the factory.

Exceptions to above warranty are: (A) Damages resulting from shipping, handling or abuse. (B) Incorrect installation and/or connections. (C) Adjustments or calibration of any parts. (D) Faults due to lack of regular maintenance or cleaning of any internal part(s). (E) Replacement of any wearable items such as: gaskets. (F) Excessive lime, mineral, alkali or hard water conditions and (G) Excessive or inadequate water temperature(s) or pressure conditions.

Models AX-413, AX-513 and AX-514 are bench warranty (Carry-In)

MVP GROUP CORPORATION STATES THAT THERE ARE NO OTHER WARRANTIES, EXPRESSED OR IMPLIED, THAT ARE NOT SET FORTH HEREIN, MVP GROUP CORPORATION SHALL ASSUME NO OTHER RESPONSIBILITY, EITHER DIRECT OR NON-DIRECT, OR BE LIABLE FOR ANY OTHER OR ADDITIONAL LOSS OR DAMAGE WHETHER BEING DIRECT OR CONSEQUENTIAL, AS A RESULT OF ITS EQUIPMENT.

CONNECTING YOUR NEW OVEN



This oven must be installed on a level, rigid, non flammable surface. Four adjustable feet must be installed to level the unit. They are located in the oven chamber.

NOTE: Be sure to provide a minimum of 2" clearance on top and both sides of unit.

NOTE: Be sure to provide adequate space for water & electrical connections.

I. WARNING

Read this instructions booklet carefully before starting the installation and start-up operations.

All installation, assembly, assistance and maintenance shall be carried out by qualified personnel and supplied with necessary professional (authorizations by the manufacturer or retailer), in accordance with local laws in effect where installation takes place regarding product and workplace safety.

Incorrect installation, assistance, maintenance, cleaning, tampering or modifications can cause malfunction, damage and breakage.

The appliance must only be used for cooking or heating of foods in commercial kitchens. Any other use is inappropriate and dangerous.



II. PRELIMINARY OPERATIONS

Upon receipt of the product, make sure it has not been damaged during transport and that the packaging has not been tampered with. In the case of damage or missing parts inform the carrier and retailer/manufacturer immediately, indicating **the model code (Art.) and serial number (Ser N°)** and attach a photo.

Check that the installation area is kept clear so that doors, corridors and passageways are accessible.

WARNING: the appliance may fall over during transport leading to breakage and damage. Use suitable transport capable of taking the weight of the appliance. Do not drag or lean the device for any reason. Lift it up straight from the ground and place horizontally.

III. INSTALLATION AREA

The appliance shall be installed indoor in a well ventilated areas (not outdoors).

Before positioning the appliance, check the overall dimensions and the exact position of the electrical, water connections.

It is advised to place the oven under a vent hood or in such a way that hot fumes and odours exit the oven via adequate ventilation to the outside.

The oven must be placed on a flat surface so that it does not slip or turn over.

The installation area must be able to support the weight of the appliance filled to the maximum.

See the information level on the back of the oven for the gross weight.

Make sure that the oven is placed so that the oven door may open fully.

Position it so that the back of the oven is easily accessible for maintenance, connection to the mains sockets, and water.

The appliance is not meant to be installed attached to a counter or walls and a 2 inch space must be left all round it. It is not advised to place it heat source like fryers or other hot liquids.

Do not place the oven near materials or inflammable liquids or material (such as walls, furniture, screens, gas canisters) as it can be a fire hazard.

When ovens are placed on cabinets, stainless steel tables or other ovens, it is not **advisable** to use shelves so high that the inside of the oven is not at eye level. Apply the sticker included in the packaging "Burning hazard", after installing the oven at a height of 5' 3" (1.600m) from the ground. (See image)

If this is not possible at least respect the following distances from machinery: 20" (50cm) from the sides and above the appliance and 27" (70cm) from behind.

IV. PREPARING FOR INSTALLATION

Remove the outer packaging (wooden caging and/or carton box) and dispose it in compliance with the laws in force in the country of installation.

REMOVING PROTECTIVE FILM ETC.

Remove the protection film from the external and internal walls. (See image)
Remove all information covering from the inside, and take off all plastic packaging.

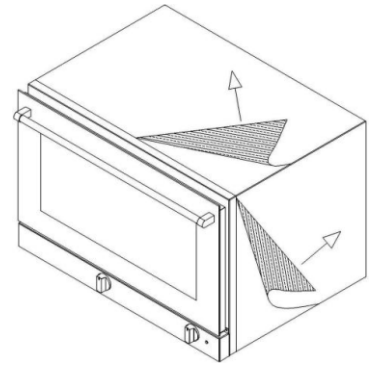

STAND ADJUSTMENT

Do not use the appliance without feet.

Inside the oven, there is a box with the legs (feet). Take the feet from the box and screw them in the positions shown. They have threaded inserts (see image). The legs give a gap that allows airflow and cooling the electric parts and outsides of the oven. If they are not used, it will cause over-heating and damage to components. The oven has to be installed on a flat surface. The unit must be leveled.

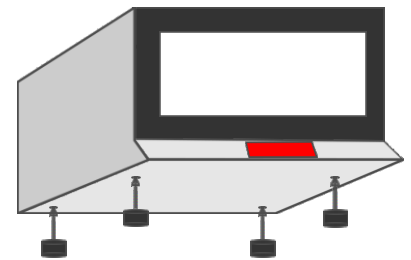

V. ELECTRICAL CONNECTION

WARNING: Mains connection must be carried out by a qualified and licensed technician or electrician according to national, international and local laws in the country where it is installed. Before mains connection, ensure that the frequency (.....Hz) and voltage (...V) meet the requirements indicated in the in the information tag on the back of the appliance.

WARNING: It is advisable to connect it first then place it in position in the work area ensuring the cable is not damaged during placement. This enables easy and safe connection. Ensure that the cable is uniformly exposed to a room temperature no higher than 125F (50°C).



OVENS WITH CABLE AND SINGLE PHASE PLUGS

For appliance with cable and plug (single phase 220-240V) the plug merely needs to go into the appropriate wall socket. The product must be positioned so that the plug is always accessible. The appliance comes with certified cable and plug therefore they must not be tampered with or modified. Only the cable can be substituted: **this must be carried out by a qualified authorized technician.** The earth wire must always be yellow green.

APPLIANCE NOT SUPPLIED WITH CABLE WITH THREE PHASE TERMINALS

Ovens are supplied with terminals such as in the image. To connect to the mains see the label in the manual and to the lower part of the back of the appliance near the Information Plate. The oven must be connected to the electricity with a rubber cable such as Cab-Tire.

WARNING: the yellow/green voltage wires in the earth cable must be 1 1/2" (3cm) longer than the others.

The oven must be connected directly to the mains, dedicated circuit, and must have an easily accessible switch. This switch must be installed according to the national, international and local laws in the country where it is installed. This switch must disconnect all poles guaranteeing complete disconnection in accordance with the overvoltage III category. Correct grounding is obligatory and the ground wire must not be operated by the protection switch.



CABLE CONNECTION

Proceed as follows to connect the power supply wire to the terminal block:

(A1) Loosen the tops of the cable gland and remove the bottom panel on the back of the appliance by removing the screws.

(A2) Feed the new cable through the cable gland. Connect the cable voltage to the terminal strips following the connection diagram on the label on the back of the appliance. Only connect what is indicated inserting the copper bridge and the electricity cable together under the screws, in the tightening direction, so the cable and the bridge are tightly fixed by tightening the screw. The type of cable to be used (HO7RN-F) is indicated on the label for each connection and the wire size is in mm².

(A4) Close the bottom panel of the back of the appliance with the screws and secure the cable by tightening the cable gland nut.

Incorrect connection could lead to overheating of the terminal board which could lead to blowout and electric shock.

Check that all the connections are tight before connecting the oven to the mains.

PE = GND = Yellow/Green:
“EARTH” protection
conductor.

N = Blue: neutral conductor.

L1, L2, L3 = Brown, Grey,

Black: live conductors

Check there is no static discharge between live and earth. Check the limit switch continuity between the external casing and the earth wire of the mains. It is advised to use a multi tester to

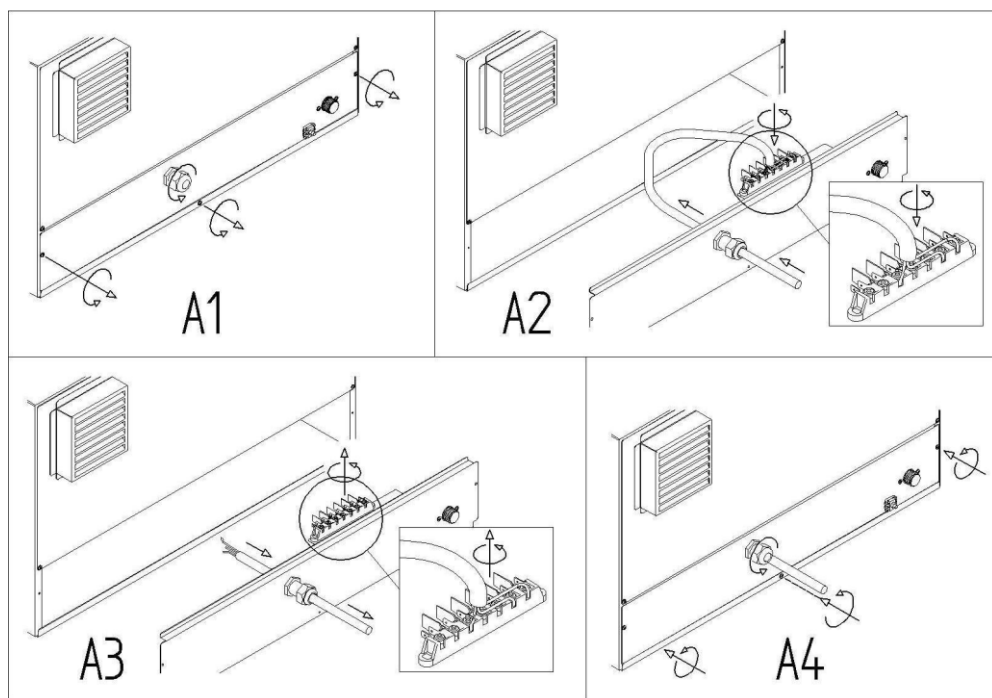

| Product Code (Ref) | AXIS MODELS | Connection references |
|--------------------|-------------|-----------------------|
| P403 | AX-413 | ETI00021 |
| P503 , G503 | AX-513 | ETI00021 |
| P503U , G503U | AX-513H | ETI00022 |
| P503UD , G503UD | AX-513RHD | ETI00022 |
| P504 , G504 | AX-514 | ETI00022 |
| P504GU , G504GU | N/A | ETI00022 |
| P504U , G504U | AX-514H | ETI00022 |
| P504UD , G504UD | AX-514RHD | ETI00022 |
| P524RU | AX-514RHD | ETI00022 |
| P524RUD | AX-P524 | ETI00020 |
| P704U , G704U | N/A | ETI00021 |
| P704UD , G704UD | N/A | ETI00022 |
| P800GU , G800GU | N/A | ETI00020 |
| P800U , G800U | N/A | ETI00020 |
| P823RU | AX-813RH | ETI00020 |
| P823RUEXP | AX-C813RH | ETI00020 |
| P824U , G824U | AX-824H | ETI00019 |
| P824UD | AX-824RHD | ETI00019 |
| P854U , G854U | N/A | ETI00019 |

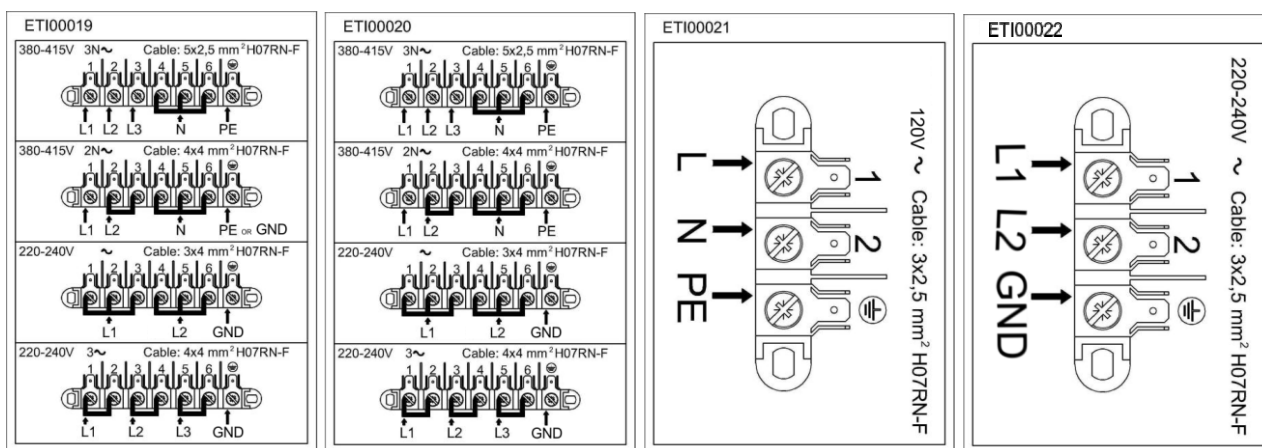

carry out these operations. The appliance must be connected to the mains using a H07RN-F cable or equivalent.

EQUIPOTENTIAL CONNECTION

Electrical bonding is the practice of intentionally electrically connecting all exposed metallic items not designed to carry electricity in a room or building as protection from [electric shock](#). If a failure of electrical insulation occurs, all bonded metal objects in the room will have substantially the same electrical potential, so that an occupant of the room cannot touch two objects with significantly different potentials. Even if the connection to a distant earth ground is lost, the occupant will be protected from dangerous [potential differences](#).



This connection shall be carried between the different appliances with the terminal marked by the symbol: (see image).

This terminal enables the connection of Yellow/Green cable (ground wire) with a section between **12 AWG (2.5mm²)** and 2/0 BWG (10mm²).

The appliance shall be included in an equipotential system whose efficiency shall be duly verified according to the provisions of the laws in force.

VI. WATER CONNECTION

A shut-off valve and a mechanical filter shall be installed to supply water to the oven. There is a G3/4" input on the back of the oven with a filter.

WARNING: only use the material supplied to connect the oven (pipe with fittings and check valve) and do not use or re-use other pipes.

Before connecting the hose to the appliance, let the water flow out to get rid of residues in the pipe. The inflowing water shall have a dynamic pressure value between 20 PSI (1,5 bar) and 30 PSI (2bar) and a maximum temperature of 90F (30°C). If the inflow pressure value exceeds 30 PSI (2bar), a pressure reducer will have to be installed, calibrated at 30 PSI (2 bar).

WATER TREATMENT

The water shall have a maximum hardness of 5 °F (for possible accumulations limestone within the cooking chamber). Use of demineralising appliances is recommended (Reverse Osmosis) with the aim of avoiding deposit of limestone and other minerals in the oven.

| American Wire Gauge (AWG) | Diameter (inches) | Diameter (mm) | Cross Sectional Area (mm ²) |
|---------------------------|-------------------|---------------|---|
| 5 | 0.1819 | 4.62 | 16.76 |
| 6 | 0.162 | 4.11 | 13.29 |
| 7 | 0.1443 | 3.67 | 10.55 |
| 8 | 0.1285 | 3.26 | 8.36 |
| 9 | 0.1144 | 2.91 | 6.63 |
| 10 | 0.1019 | 2.59 | 5.26 |
| 11 | 0.0907 | 2.3 | 4.17 |
| 12 | 0.0808 | 2.05 | 3.31 |

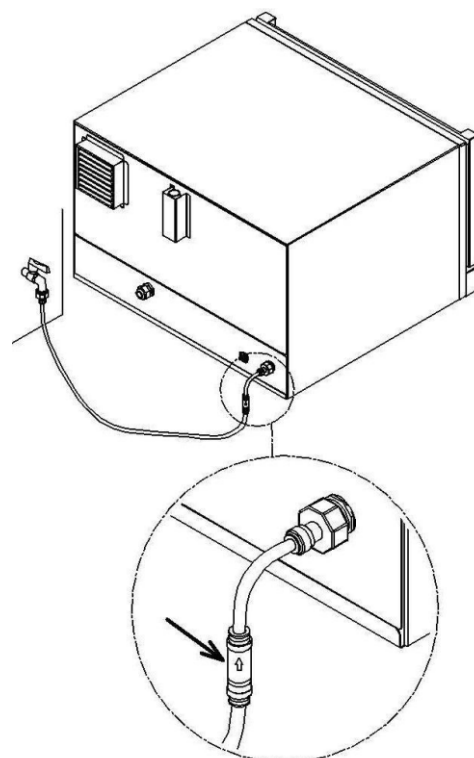

| Unit | mekv/l | °dH (°dH) | °e | °f (°tH) | mg/l CaCO ₃ | gpg CaCO ₃ |
|--------------------------|--------|-----------|--------|----------|------------------------|-----------------------|
| 1 mekv/l | 1 | 2.805 | 3.51 | 5 | 50 | 2.924 |
| 1 °dH (°dH) | 0.3536 | 1 | 1.25 | 1.78 | 17.8 | 1.042 |
| 1 °e | 0.2852 | 0.8 | 1 | 1.43 | 14.3 | 0.833 |
| 1 °f (°tH) | 0.2 | 0.561 | 0.702 | 1 | 10 | 0.585 |
| 1 mg/l CaCO ₃ | 0.02 | 0.0561 | 0.0702 | 0.1 | 1 | 0.0585 |
| 1 gpg CaCO ₃ | 0.342 | 0.9593 | 1.2004 | 1.71 | 17.1 | 1 |

According to definition, water hardness is a value characteristic of the dissolved salts found in water (calcium and magnesium hydrogen-carbonate, °dH = 0.357 meq/l).

VII. VENT CONNECTION FUMES DISCHARGE

Hot fumes and odours are emitted from the cooking chamber during cooking. This is located at the top part of the back of the oven. Do not place objects on the discharge so as not to hinder the outflow of the fumes and hence avoid causing damage thereto. It is advisable to position the oven under an adequate ventilation to outside for hot fumes and odours through a pipe or duct no smaller than the oven vent. Avoid bends and blockages.

VIII. STACKING OVENS

Stacking several ovens requires the use of the special kit which keeps the correct distance between the two ovens.

IX. SERIAL PLATE

P504UD — D: electrically operated version
 — U: with humidifier
 — Interface identification n° of baking trays
 — P= baking oven / G= cooking oven

P504GU — U: with humidifier
 — G: with GRILL resistance
 — Baking tray n°
 — P= baking oven / G= cooking oven

IMPORTANT NOTE:

- Reasonable access to and around the machine must be provided for service.
- Disconnecting of hard plumbing or removal of counter tops or cabinets, etc. for servicing is not covered by warranty.
- It is important to reinstall all body panels that were removed during installation.

INFORMATION PLATE

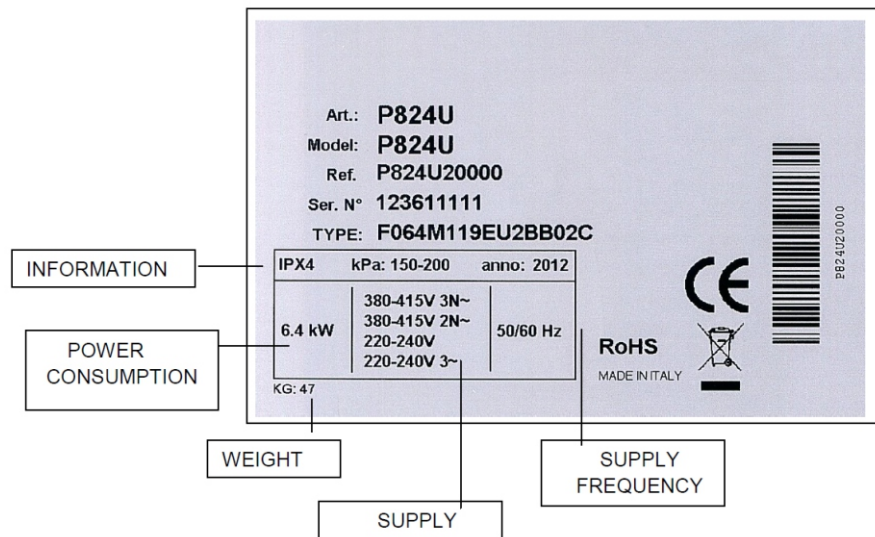

INSTRUCTIONS FOR THE USER

I. WARNING

Read this instruction booklet carefully. This manual provides instructions regarding safety and use of the appliance.

Keep carefully for reference at all times.

Incorrect installation, assistance, maintenance, cleaning, tampering or modifications can cause malfunction, damage and breakage.



The oven must only be used for foods in commercial kitchens. Any other use is inappropriate. MVP Group Corp shall be deemed relieved from any liability arising from uses different from one indicated in this manual.

The oven may be used for the following:

- Baking fresh and frozen pastries and bread
- Cooking all food refrigerated and frozen food products
- Reconditioning refrigerated and frozen food products.

The appliance is intended for commercial use and it shall be used by qualified personnel. The appliance is not suitable for use by people with low physical or mental abilities or lacking experience, unless instructed on the operation of the oven by the personnel in charge of safety their safety. Keep the oven out of reach of children.

It is strongly recommended not to place heat sources near the oven.

Do not under any circumstance, leave flammable material near the appliance: it can be a fire hazard. Food container temperatures, accessories or other objects can be very hot; beware of burns when moving them. Only touch them with relevant thermal protection.

While opening the oven door: danger of scalding due to high temperature emissions.

Do not put flammable or alcohol based foods in the oven as they can cause combustion and explosions. Avoid putting salt on food inside the cooking chamber of the oven. If this cannot be avoided, ensure that it is cleaned as soon as possible as it can cause damage to the cooking chamber.

Use your fingers to manipulate the controls; the use of any other object may damage the oven hence nullify the validity of the warranty.

The exterior of the oven can exceed a temperature of 60°C, therefore in order to avoid burns it is advised not to touch the external parts marked by the symbol shown here.



Damaged or broken glass door components must be replaced immediately (contact the customer support @ 1 888 275 4538).

When not in use for extended periods (for example 12 hours) it is advisable to leave the door slightly open.

If it is not in use for long periods of time (many days) it is advisable to turn it off at the breaker and disconnect the water supply.

MVP Group Corp shall not be deemed liable for any damage incurred by persons or properties, caused by noncompliance with the aforementioned instructions of deriving from tampering with even a single part of the appliance and use of non-genuine spare parts.

This appliance complies with the EU directives in force.

II. USING FOR THE FIRST TIME

Make sure all points required to ascertain a strict adherence with the soundness of the systems and the installation of the appliance with the law regulations as well as technical and safety instructions provided for by this manual are as well are carried out before operating the appliance.

There should not be plastic bags inside it, instruction manuals, plastic film or anything else.

Ensure that the baking tray holders inside the cooking chamber are well secured to the oven walls. If not secured, the baking trays containing food or hot liquids could fall resulting in scalding.

All packaging should have been entirely removed, including the protective film applied on the walls of the oven.

The vents and aeration openings should be open and clear of obstructions.

TESTING

The oven is tested by completing a sample cooking cycle which verifies whether the oven operates correctly and is free of failures or problems.

Start the oven and set a cooking time and temperature for 10 minutes at 300F (150° C) at medium humidity.

Thoroughly verify the conditions listed below:

- The cooking chamber light is ON.

- On reaching the set temperature, the cooking temperature thermostat turns off the heating elements.

- The cooking chamber fans spin in the same direction (for units with two fans).

- Check outflow of water on the fan from the pipe for introducing moisture into the cooking chamber.



CONVECTION OVEN QUICK GUIDE



Press the **ON/OFF** button

Unit is in Manual Mode



Firmly press the **clock** symbol to change times. "END" will flash



Up arrow will increase by minutes



Down arrow, from end will go to "Infi", the unit will run until the user decides to stop it.

The chosen time will flash for 3 seconds then stop flashing.



Pressing the **UP** or **Down** arrow will change the temperature. When the temperature is flashing, press the arrows to change the setting. Once it has stopped flashing the unit is ready to start.



Firmly press firmly **start** to begin cooking.

When the unit has finished the given time, it will emit a beeping sound.

If you open the door during the cooking time, the clock will stop and only continue cooking once the door is closed again.



Unit can inject steam manually during the cooking time by pressing the steam symbol

Note; It is not recommended to inject steam/water if the unit is not at least 200F.

Note: The fan motors will stop after 90 seconds, then change direction 20 seconds later.



CONVECTION OVEN QUICK GUIDE

Programming



Press **P/M**; P 01 will blink.



Press **up** or **down** arrow to choose a program.
The given program will blink/flash for 4 seconds.



Press **Start** to begin program

The indicator light on the right will show which phase it is currently in.

To change the parameters



Press **F** to select the phase.



Press the **clock** symbol, time will blink. Press the **arrows** to change the time.
Once the change is made, wait 3 seconds or press the clock symbol again.



Press **arrows** to change the temperature. Temperature will blink while you are changing it. Wait 3 seconds after your done or press the clock symbol again.



Press **steam** symbol to inject water in the cooking chamber. Choose a percentage (0,20,40,60,80 and 100%). This should be done when temperature is right (+200f). Normally it will be set at F2 & F3.



Press **F** to select the next phase.



Once all your changes are done, press and hold **P/M** 4 seconds to record the changes. It will emit a beeping sound when it is done.

MECHANICAL CONTROLS

TIMER KNOB

Cooking time can be selected up to 2 hours by turning the knob clockwise.

Turning the knob counter-clockwise will put the machine in continuous mode

THERMOSTAT KNOB

This knob allows selecting the desired cooking temperature.

THERMOSTAT LIGHT

This light is on when the heating elements are working therefore the temperature in the cooking chamber is less than that set by the thermostat dial. When the light goes off it means that the heat is off and that the cooking chamber has reached the set temperature.

HUMIDIFIER BUTTON

This button enables humidifying for the length of time it stays pressed.

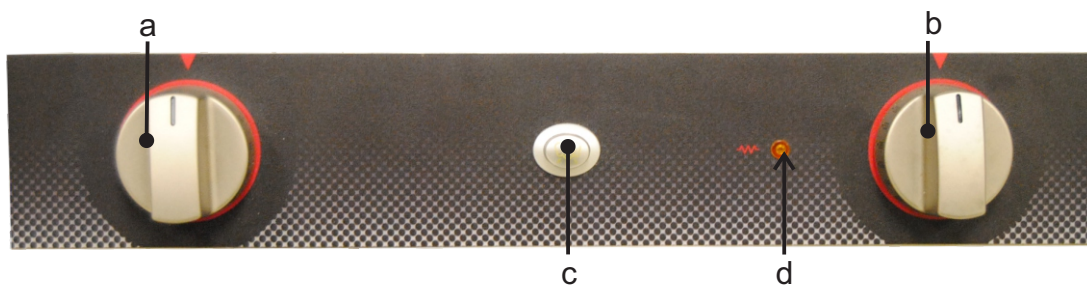

- a Timer Knob
- b Thermostat Knob
- c Humidifier Button
- d Thermostat Light

ELECTRONIC CONTROLS

ON/OFF button

When power is supplied to the oven the control panel lights up and the operating display indicates off. Activating the control panel requires pressing the on/off button.

START/STOP button

This button starts/stops a previously set program or cooking cycle.

TEMPERATURE

When the oven is on "ON" the temperature display shows the temperature in the cooking chamber.

To set the desired cooking temperature press INCREASE (2) or DECREASE (4) buttons (arrows up and down). The temperature display will show the set value. The new value will be memorised by waiting 5 seconds or by pressing the TIME button to see the temperature value in the cooking chamber.

Values go from 90F to 500F (30°C to 260°C).

During cooking the CHAMBER display alternately shows set temperature (TEMPERATURE icon fixed on) with the actual internal chamber temperature (TEMPERATURE icon flashing). RESISTANCE icon is on red when the heat is on and green when it is off.

TIME BUTTON

The value on the display starts to flash when pressing "TIME" and the value can be changed by pressing INCREASE or DECREASE buttons. The CLOCK icon turns on.

The programmable times range from 00hours and 01minutes to 15hours and 59minutes.

To go below the minimum value of 00hours and 01minutes go to:

- END: used from programmed cooking to disable unnecessary phases.
- INF: means "infinite time" the oven will continue to work with the set parameters until START/STOP button is pressed.

The new value is memorized by waiting 5 seconds or by pressing the TIME button.

The time display is by countdown in hours, minutes and seconds during cooking. A value can be changed to infinite time (INF) and vice versa.

MOISTURE/STEAM BUTTON

During cooking, the STEAM icon goes on when steam is being released into the cooking chamber and it flashes when on pause.

PROGRAMS/MANUAL BUTTON

While set at ON, cooking can either be selected manually or programmed.

This button also allows the saving of 99 programs developed by us.

PHASES button

There are 3 different programmable cooking phases. You can program the oven to cook with three different cooking temperatures, times and humidity settings.

MANUAL COOKING

After setting TIME and TEMPERATURE, the cooking cycle begins by pressing START/STOP. The cooking cycle may be stopped at any time by pressing START/STOP. Remaining cooking time can be seen on the display.

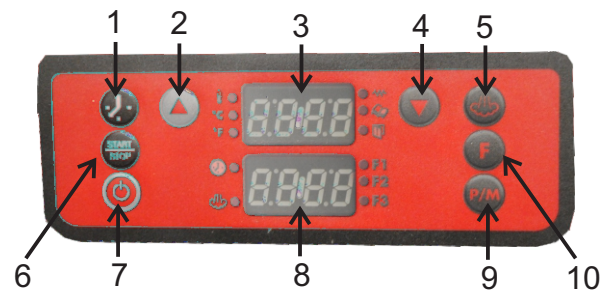

- 1 Time Button
- 2 Increase Button
- 3 Temperature Display
- 4 Decrease Button
- 5 Humidifier Button
- 6 Start/Stop Button
- 7 ON/OFF Button
- 8 Time/Steam Display
- 9 Program Button
- 10 Phase

The cooking cycle will start again by pressing START/STOP from where it left off. END flashes on the display at the end of a cooking cycle, fan, humidifying and heating stop and it beeps for 40 seconds. If a time is programmed during these 40 seconds using the INCREASE / DECREASE buttons and is confirmed by pressing the TIME button, the oven will automatically start cooking again with the previous temperature parameters.

Otherwise START/STOP stops the beep and the oven stops completely.

The oven turns off automatically after 15 minutes of each cooking. To turn it ON again, press ON/OFF.

PROGRAMMED COOKING

The oven has a possibility of 99 pre-programmed recipes, each one with 3 cooking phases.

To put the oven on MANUAL press PROGRAMS / MANUAL once. This enables PROGRAMS and the PROGRAMS LIBRARY light and PHASES comes on.

Recipe P01 can be seen on the CHAMBER/PROGRAMS display. Select the cooking program with INCREASE / DECREASE and the saved values will appear on the display after 5 seconds.

Now the time, temperature and humidifying can be set in the various phases as previously described. The PHASES icon always shows the current program phase.

By pressing PROGRAMS/MANUAL once at any time the program can be viewed.

By pressing START/STOP once the cooking program starts.

END flashes on the display at the end of a cooking cycle, fan, humidifying and heating stop and it beeps for 40 seconds. If a time is programmed during these 40 seconds. After the 40 seconds the beeping stops and the oven is ready to repeat the same previously selected program.

Otherwise START/STOP stops the beep and the oven goes back to MANUAL COOKING.

PROGRAM MEMORIZATION: keep PROGRAMS/MANUAL pressed for per 4 seconds. Memorization is confirmed by a beep for a few seconds and the program number with MEM will appear on the display.

RETURN TO MANUAL COOKING: to go back to MANUAL you have to follow the procedure below to exit programs:

Press PROGRAMS/MANUAL once and the previously selected cooking program number will flash for 5 seconds. By pressing PROGRAMS/MANUAL once during these 5 seconds, MANU (manual) will appear on the display. Wait 5 seconds to confirm selection.

In manual cooking the icons PROGRAM LIBRARY and PHASES will turn off.

| COOKING PROGRAMS | | | | |
|------------------|-------|-------|------|-------|
| P# | PHASE | TIME | TEMP | HUM % |
| PD1 | 1 | 00:05 | 375F | 0% |
| | 2 | 00:25 | 350F | 20% |
| | 3 | 00:10 | 300F | 5% |
| PD2 | 1 | | | |
| | 2 | | | |
| | 3 | | | |
| PD3 | 1 | | | |
| | 2 | | | |
| | 3 | | | |
| PD4 | 1 | | | |
| | 2 | | | |
| | 3 | | | |

SET PARAMETERS

PRE-HEATING

Pre-heating allows the oven to come up to the desired temperature before it is ready to cook. To change the setting for the pre-heating option do the following:

keep INCREASE – DECREASE pressed at the same time for 4 seconds, then press INCREASE until “language” comes up on the display. Press INCREASE to change the desired menu until you reach “Pre-Scaldo”, press HUMIDIFYING to access the menu, press INCREASE– DECREASE to select the ON or OFF, confirm selection by pressing START/STOP.

To exit the menu press ON/OFF.

FIRST TIME CLEANING THE COOKING CHAMBER OF THE OVEN

Disconnect the electrical power from the appliance and wait until the oven is cooled completely before cleaning.

WARNING: the appliance should never be cleaned with high pressure water sprays.

There should never be any residue of solvents or detergents. They should be removed by rinsing thoroughly using a damp cloth. Appropriate eye, mouth and hand protection should be used. Possible danger of corrosion.

Heat the oven empty up to 200° C (392° F) for about 30 minutes so as to eliminate thermal insulation odours. Clean the walls of the cooking chamber using hot water and soap, then rinse; never use aggressive or acid products.

REGULAR MAINTENANCE

The user is solely responsible for regular maintenance. The customer support center must be contacted for special maintenance which requires a specialised authorised technician.

CLEANING: GENERAL RULES

Disconnect electrical power from the appliance and wait until the oven is cooled completely before cleaning.

WARNING: the appliance should never be cleaned with high pressure water sprays.



REGULAR CLEANING OF COOKING CHAMBER

It is recommended to clean the cooking chamber daily so as to maintain correct levels of hygiene and avoid the deterioration of steel.

Do not use high pressure water steam lances or steamers for cleaning. Acidic, abrasive, corrosive sand-based or caustic soda based detergents are prohibited.

For manual cleaning follow the procedure below:

- Turn on the appliance and set the temperature to 175°F (80°C).
- Leave it on for 10 minutes on steam.
- Turn off the appliance and let it cool down.
- Clean with hot water and soap then rinse.

It is strictly prohibited to wash the cooking chamber with cooking temperatures higher than 155°F (70°C), definite danger of scalding.

Daily cleaning of the oven cooking chamber lining must be carried out with a non-abrasive detergent to guarantee its full function.

Use plastic bristles or a sponge with vinegar and warm water in case of dirt crusts.

Warning: fat residue possibly present in the cooking chamber could catch fire when using the oven, hence it is advisable to remove them quickly.

Only use products recommended by the manufacturer of the appliance.

EXTERNAL CLEANING

Only use a damp cloth with warm water or products suitable for cleaning stainless steel. Do not use acidic products or ammonia.

WARNING: the appliance should never be cleaned with high pressure water sprays.

REPLACING LIGHT LAMPS

WARNING: Strictly adhere to the following procedure in order to avoid electrocution or damage to people:

- Disconnect the electrical connection of the oven and leave it to cool.
- Take off the side grids that hold the baking trays.
- Unscrew the glass cover "A" while observing "C".
- Replace the lamp "B" with one having the same characteristics.

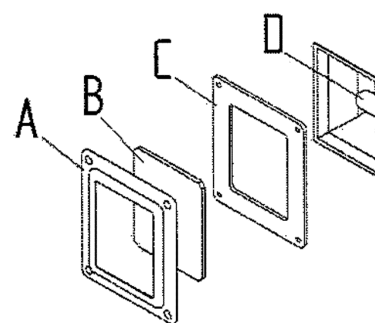

- Screw back on glass cover “A” while observing washer “C”.
- Put the side grids back on ensuring they are well fitted.
- Should the glass lid be broken or damaged, do not use the oven until the lid is replaced (Contact the customer support Centre).

REPLACEMENT AND CLEANING OF COOLING FILTER

WARNING: Strictly adhere to the following procedure in order to avoid electrocution or damage to people:

- Disconnect the electrical connection of the oven and leave it to cool.
- Loosen the grid screws and substitute or clean the filter.
- Once this is done put everything back together.

SPECIAL MAINTENANCE

It is advisable to have the appliance subjected to periodical checks (at least once per year) by a specialised authorized technician.

Any maintenance, installation or repair work must be carried out by qualified authorized personnel by contacting the Customer Support Centre. Before carrying out any operation the appliance must be unplugged at the mains, close the water valve and wait for it to cool down. Before moving the appliance from position, check that the electricity and water connections (electric cables, water pipe and drainage) are correctly disconnected.

If the appliance is on wheels check that electric cables, pipes or anything else are not damaged while moving it. Ensure the wheel-break is on. Avoid placing the device near heat (such as fryers etc.). After carrying out the task and replacing the appliance in it's initial position, check that the electric and water are connected correctly.

MAINTENANCE IN CASE OF BREAK-DOWN

If the appliance breaks, disconnect it from the mains and turn off water. Before calling Customer Service, check the chart on page 22.

POWER FAILURE

In case of power failure during the cooking cycle, the oven turns automatically into the OFF position.

SIGNALS AND ALARMS

Alarms appear on the display while everything else is off and a beep warns of an anomaly. The beep can be stopped by pressing START/STOP.

ER1 Chamber Probe Alarm.

It occurs in case of failure of the chamber probe.

The oven is deactivated completely except for the light and the cycle in progress is interrupted.

ER2 Oven Safety Thermostat Alarm.

It occurs in case of malfunctioning regarding the heating of the oven.

The entirety is deactivated and the cycle in progress is interrupted.

TROUBLESHOOTING

| PROBLEM | CHECK | ACTION |
|---|---|---|
| The oven is completely OFF. There is no water coming from solenoid. | Safety thermostat | Requires service technician for repair |
| | Water inlet is closed | Open water inlet valve |
| | Incorrect connection to water | Check connection to water supply |
| Non-uniform cooking | Fan(s) no longer invert rotation during cooking | Requires service technician for repair |
| | One of the fans is not working | Requires service technician for repair |
| Non-uniform cooking The oven is completely OFF | Heating element is defective | Requires service technician for repair |
| | Supply voltage inadequate | Check breaker or fuse |
| | Incorrect connection to power supply network | Check connection to power supply |
| There is no water inflow from the humidifier pipes Water leaking from the gaskets with the door open | Water filter is blocked with impurities | Clean filter |
| | Dirty lining | Clean lining with damp cloth |
| | Damaged Gasket | Replace gasket |
| Water leaking from the gaskets with the door open The fan stops while the oven is on | Door does not close properly | Verify door mechanism |
| | Safety Thermostat or motor may be defective | Turn off the oven and wait for the motor's thermal protection to reset itself. If the problem persists call a specialised repair technician |
| | Motor Capacitor defective | Requires service technician for repair |
| Light does not work | Loose light bulb | Correctly fit bulb in socket |
| | Light bulb is burnt | Replace light bulb |

SCHEDULED MAINTENANCE

- ❖ **DAILY**, at day end or when the cooking chamber becomes soiled:
 - Turn OFF the power and let cool down.
 - Wipe down the outside of the oven.
 - Remove the rack.
 - Remove rack support.
 - Clean the racks with a brush (Nylon bristles) and mild detergent solution. DO NOT use steel wool. Rinse well.
 - Clean all food particles in the cooking chamber. DO NOT use pressured water in the oven.
 - Wipe clean the interior of the door and the interior of the oven with a damp cloth.
 - Replace and secure all parts that were removed to their original position and close the door.
 - Leave the power OFF.

- ❖ **WEEKLY:**
 - Same as above plus;
 - Remove rear cover panel inside the oven for cleaning.
 - Visual Inspection.
 - Any broken or cracked glass should be replaced.
 - Treat for mineral accumulation if necessary.
 - If your oven has mineral (calcium) accumulation (you will notice a white-colored film inside the unit), it must be treated with a de-scaler. Please contact us for more details.

CONTACT INFORMATION



MVP GROUP CORPORATION
12000 Biscayne Blvd, Suite #108
Miami, FL, United States 33181
Telephone: (786) 600-4687
Toll Free Telephone: 1-844-218-8477
Fax: (786) 661-4100
Email: service@mvpgroupcorp.com

5659 ROYALMOUNT
MONTREAL QUEBEC
CANADA H4P 2P9
514 737 9701 888-275-4538
514 342 3854
WWW.MVPGROUPCORP.COM

IMPORTANT NOTES

Locate and clearly identify the water shut-off valve that supplies the machine and the fuse box or breaker switches.

Only qualified and/or licensed technicians can repair this piece of equipment. Removing panels will expose wires and live current. The breaker should be switched off or fuses removed before removing the panels. The water supply must also be turned off.

