

WALKING PAD USER MANUAL



CAUTION

Read all precautions and instructions in this manual before using this equipment. Save this manual for future reference.

TABLE OF CONTENTS

Warranty Information & After-Sales Service	1
Important Precautions	2
Product Specifications	3
Packing List	5
How to Use the Walking Pad	6
LED Monitor Instruction	7
Description of Remote Control Buttons	8
Troubleshooting and Maintenance	10
Maintenance Instructions	12
Exercise Guidelines	15
Suggested Stretches	16

Warranty Information & After-Sales Service

Welcome to using Lichico series products. This product comes with a **2-YEAR FREE WARRANTY** for normal use, provided that it is not damaged by human intervention. Please note that our company is not responsible for any failures caused by incorrect installation, incorrect use, or replacement of parts, and the warranty does not apply to unauthorized repairs, including resulting repair costs which are the responsibility of the customer.

Please note that this product is intended for home use only, and our company is not responsible for any problems caused by commercial use.

After-sales Service

If you encounter any product problems or have lost the remote control, please contact us through the following methods. We provide 24/7 customer service and support.

Service Team contact information

Important Precautions

1. Carefully read the user manual before using the product.
2. The product must be grounded properly when connected to the power supply. Failure to do so may result in electric shock.
3. Do not replace or modify any parts of the treadmill to ensure safety.
4. Use the treadmill normally according to the user manual and do not remove any parts to avoid injury, such as the motor cover or the rear roller cover.
5. Do not touch the moving parts while the treadmill is in operation and keep children away from it.
6. Exercise moderately to avoid health damage. Stop exercising immediately if you feel dizzy.
7. Wait for the running belt to stop before folding it.
8. If the power cord is damaged, replace it with the help of the manufacturer, its service department, or a professional worker to avoid danger.
9. This product is only suitable for adults in good physical and mental condition. Please do not let children use it.

Product Specifications

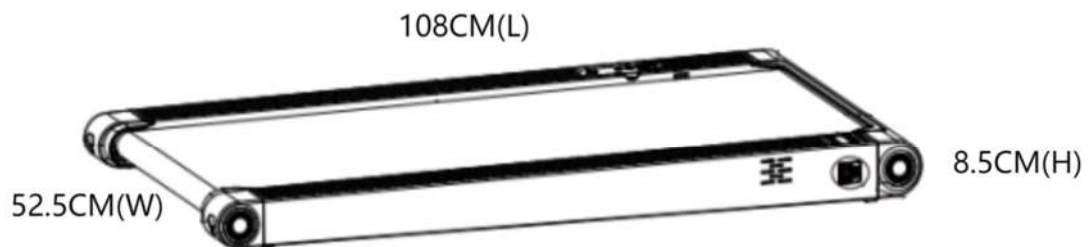
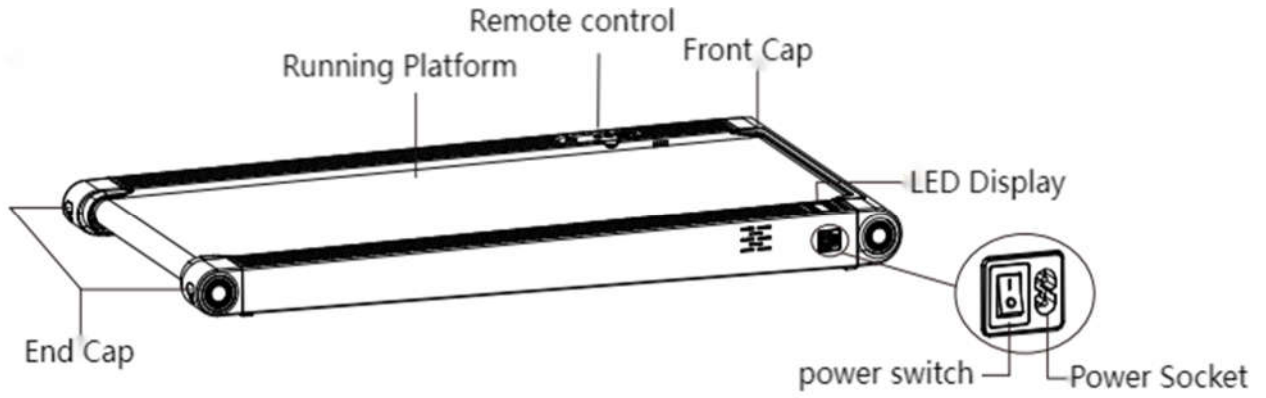

Product name: Walking Pad Treadmill

Product model: 38AG

Product dimensions: 108cm (L), 52.5 (W), 8.5cm (H)

Running area: 1000*380MM

Speed range: 0.8-6 KM/H

Weight capacity: 100KG

Motor horsepower: 1.5 HP

Net weight: 11KG

Gross weight: 14KG

Rated voltage: 220V

Class: HC

①Reminder: The product size, net weight, and gross weight provided are approximate values. For specific size and weight information, please refer to the actual product.

Bluetooth APP:  Besyfit.





JOIN THE APP Besyfit

Scan the QR code to download



Packing List

1. Walking Pad Treadmill
2. Accessory kits:
 - 1) Remote controller x 1
 - 2) Silicone oil x 1
 - 3) L spanner x 1
 - 4) User manual x 1

Treadmill	Remote controller	Silicon oil
		
	<p style="text-align: center;">L spanner</p>	<p style="text-align: center;">Manual</p>
		

How to Use the Walking Pad

To quickly use the walking pad, please follow these steps:

1. Connect the power to the walking pad.
2. Turn on the power switch located on the front of the deck.
3. Press the "Start/Stop" button on the remote controller to start the walking pad, and the LED monitor will display "3-2-1", with the buzzer sounding once for every count down. After this, the motor will start running.
4. Once the walking pad is running, you can use the remote controller's "speed +" and "speed -" keys to adjust the speed according to your needs. The data on the LED monitor will automatically cycle and display every 5 seconds while the walking pad is in use.
5. To stop the walking pad, press the "Start/Stop" button on the remote controller.

LED Monitor Instruction

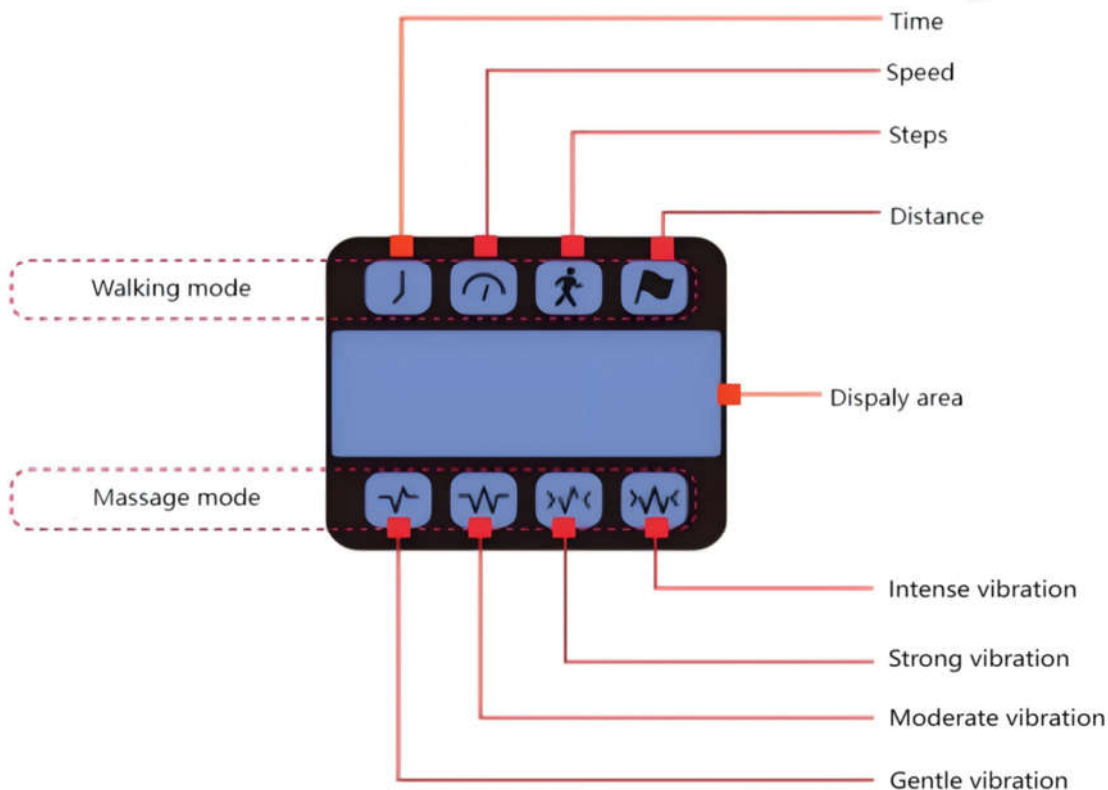



The LED window on the walking pad displays the following functions:

- A. Time Window: Shows time. Range: 0:00 - 99:59. The time indicator light is lit when displaying time.
- B. Speed Window: Shows speed. Range: 0.8 - 6.0 km/h. The speed indicator light is lit when displaying speed.
- C. Step Count Window: Shows distance data. Range: 0 - 99999. The distance indicator light is lit when displaying distance.
- D. Calories Window: Shows calories data. Range: 0 - 9999. The calorie indicator light is lit when displaying calories.
- E. Distance Window: Shows distance reading. Range: 0 - 9999. The distance indicator light is lit when displaying distance.
- F. Displays F01: Gentle vibration. Vibration level 1 indicator light is lit.
- G. Displays F02: Moderate vibration. Vibration level 2 indicator light is lit.
- H. Displays F03: Strong vibration. Vibration level 3 indicator light is lit.
- I. Displays F04: Intense vibration. Vibration level 4 indicator light is lit.

Description of Remote Control Buttons

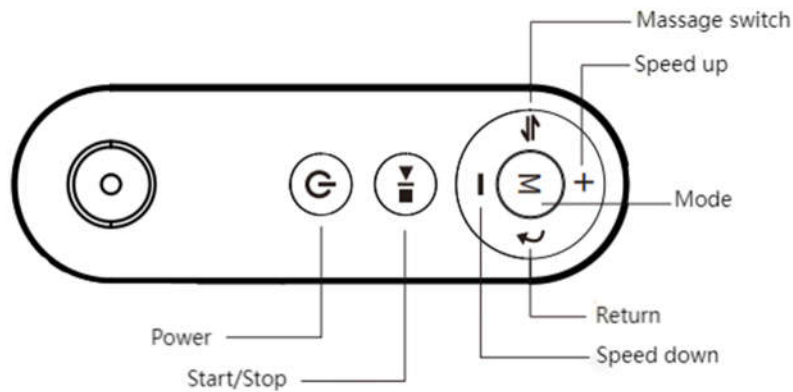
Remote control function buttons: power, start/stop, mode, speed increase and decrease. massage switch



 The "Power" button is used to turn off the walking pad when it is running. When the walking pad is in standby mode, pressing this button will turn off the display and enter sleep mode.

 The "Start/Stop" button is used to start or stop the walking pad. When the power is turned on, pressing this button in the stop state will start the walking pad. Pressing the button when the walking pad is running will stop the walking pad.

 The "Mode" button is used to select the countdown mode for time, distance or calorie, as well as a free mode. Pressing this button will cycle through the options of "30:00" (time countdown mode), "1.0" (distance countdown mode), "50.0" (calorie countdown mode), and "0.0" (free mode).

 The "Speed +" button is used to increase the speed of the walking pad after it is started. After a single press, the speed will be adjusted by 0.1 KM/H. When the button is pressed continuously for more than 1 second, the speed will continue to increase.

— The "Speed -" button is used to decrease the speed of the walking pad after it is started. After a single press, the speed will be adjusted by 0.1 KM/H. When the button is pressed continuously for more than 1 second, the speed will continue to decrease.

↔ The "Massage switch" button is used to switch between massage and walking modes. When the treadmill is in standby mode, the massage mode can be activated and different massage modes can be switched. The display screen will correspondingly show F01-F04, and the corresponding indicator lights will also light up. This mode is not available in the walking mode.

↵ The "Return" button is used to exit the settings when use the "M" key to set the mode.

Usage Precautions

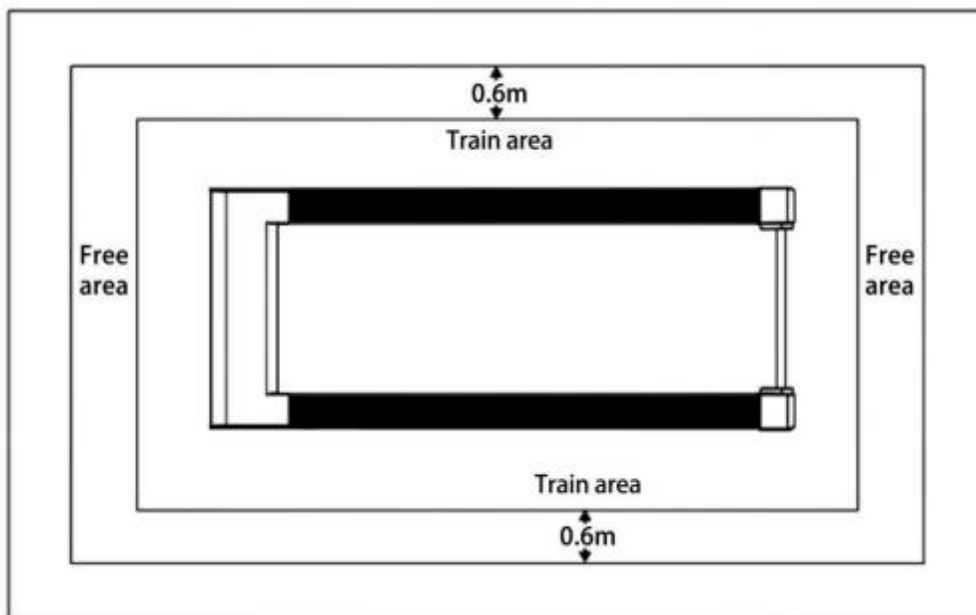

1. There should be sufficient space around the walking pad, and a safe area of 2000mm*1000mm behind the walking pad should be maintained.

2. Children should not be allowed to use the walking pad to prevent potential hazards.

3. Prior to using the walking pad, it is recommended to warm up.

4. The walking pad should be placed on a stable and level surface.

5. While using the walking pad, it is recommended that the user stands on one-third of the walking surface at the front of the walking pad for walking.

6. The product's free area in the direction of use must be at least 0.6m larger than the training area, including the emergency jumping area, as shown in the figure.

Troubleshooting and Maintenance

Fault Code	Main reason	Solution
Treadmill not working	A. No power	Plug in to get power
	B.Connection wire not work well	Check all connection wire
Belt not running smoothly	A.Lubrication oil is less	Add some silicon oil
	B.Running belt is too tight	Loosen running belt
E01	The wire from computer to bottom control board didn't connected well	<ol style="list-style-type: none"> 1. If communication between the electrical control and screen is obstructed, check each connection of the communication line from the screen to the lower control, ensuring that each wire is properly connected. 2. Check if there is any wire damage between the screen and controller, and replace the communication line if necessary.
E02	IGBT breakdown or motor open circuit (DC brushless motor is over-voltage, under-voltage)	<ol style="list-style-type: none"> 1. Check if the power supply voltage is below 50% of the normal voltage, and retest using the correct voltage specifications. 2. Check if there is any abnormal odor coming from the controller, and replace it if necessary. 3. Check if the motor wires are properly connected, and reconnect if needed.
E03	Speed sensor fail	<ol style="list-style-type: none"> 1. If no speed sensor signal is detected for 5-8 seconds, check whether the sensor plug is properly connected or damaged, and reconnect or replace the sensor accordingly. 2. Check if there is any abnormal odor coming from the controller, and replace it if necessary. 3. If there is no motor input signal detected for 5-8 seconds, check whether the motor wires are properly connected or if the motor is defective.

E05	Over-current Protection	<ol style="list-style-type: none"> 1. The system may be drawing excessive current due to the load being over the rated capacity, triggering the protective shutdown. The system can be restarted after a complete shutdown. 2. If a certain part of the treadmill becomes stuck, it can cause the motor to be unable to rotate normally, resulting in excess load and current flow. This may trigger the system protection and shut down the system. To resolve this issue, the treadmill needs to be adjusted and once done, the system can be restarted for normal operation. 3. Inspect the motor for any signs of excessive noise or a burning smell during operation. If such signs are present, it may indicate a faulty motor that needs to be replaced. 4. Check if there is any burnt smell coming from the components of the controller. If any components show signs of damage, it may indicate a faulty controller that needs to be replaced. 5. Inspect if the power supply voltage are incorrect or lower than required. Use the appropriate voltage and retest the machine. For DC brushless machines, also check if the motor wires are properly connected.
E08	Driver failure (internal self-test error 'driver overheating')	<ol style="list-style-type: none"> 1. Wait for a period of time, then restart the power after it has cooled down. (Only applicable for brushless controllers.) 2. The controller is faulty. Replace the controller.
E09	Communication failure	<p>If the lower-level controller is not receiving signals from the higher-level controller, replace the communication cable and check if the communication port is functioning properly.</p>
E10	Motor open circuit	<ol style="list-style-type: none"> 1. Check whether the motor wires are properly connected, and reconnect if necessary. 2. Check if the motor brushes are stuck.

Maintenance Instructions

Walking pads require regular maintenance and upkeep.

We recommend the following:

1. Check the equipment frequently for wear and damage, such as the running belt and attachment points. After repairing any issues, the equipment should remain safe for a period of time.
2. If the walking pad experiences a malfunction, do not use it. Seek guidance and replace any defective parts as needed.
3. How to adjust the running belt tension and off set position:

(1) Adjustment of running belt tightness

Before leaving the factory and after installation, the running belt needs to be adjusted. However, after a period of use, it may become loose, causing the belt to slip or pause. In this case, adjust the running belt by turning the adjustment bolts clockwise in half-circle increments. If the running belt is too loose, it will slip when stepped on, while being too tight can increase the electric load and damage the motor, running belt, and roller, etc.

(2) Running belt deviation adjustment

All treadmills need to be adjusted before leaving the factory and after installation, but it may still become misaligned due to following reasons:

- a) Uneven placement of the walking pad
- b) The user's feet not being in the center of the running belt when running.
- c) The uneven force of the user's feet causes the deviation. The deviation can sometimes be self-corrected after a few minutes of no-load rotation, but if it persists, the user can use a T-type wrench to gradually adjust it in units of a quarter of a turn.

It's important to note that the deviation of the running belt is not covered by the warranty and users should follow the instructions for self-maintenance. Failure to correct the deviation in time can seriously damage the running belt.

d) To adjust the running belt deviation, start the walking pad at a speed of 3MPH and then use the method shown in the figure for adjustment.

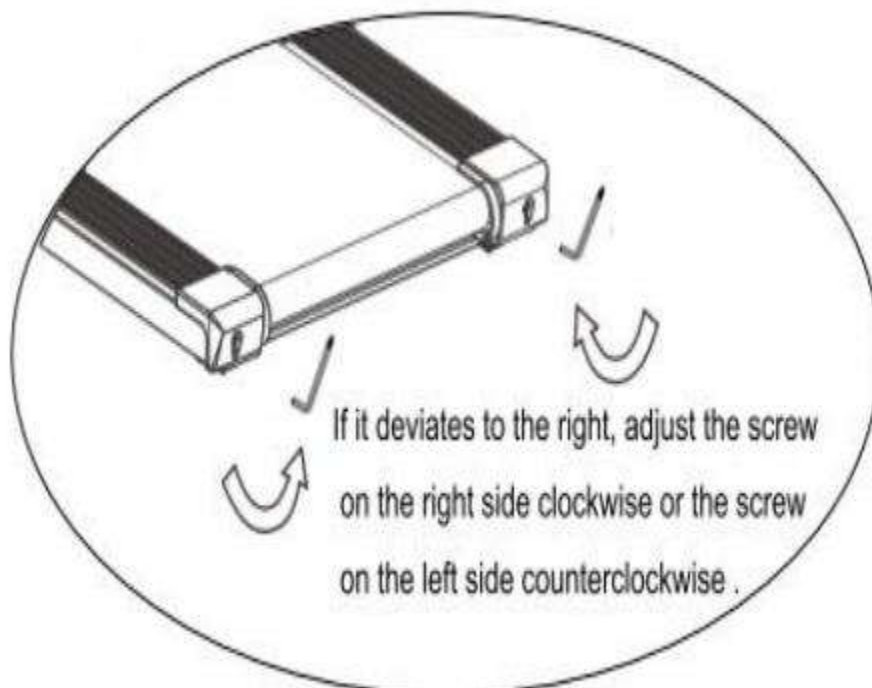
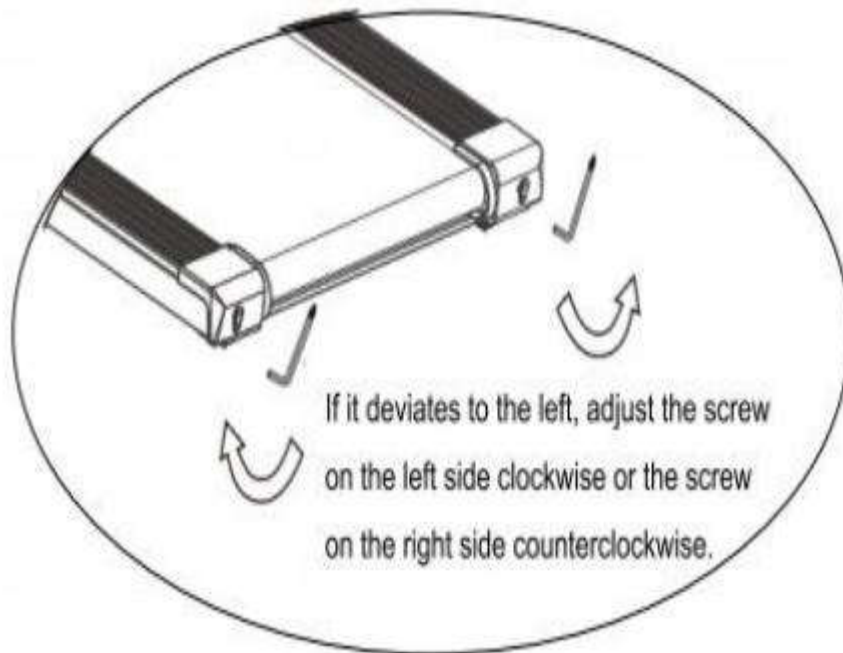

(3)Lubrication

After the running belt has been used for a period of time, it must be lubricated with a special configuration of methyl silicone oil. Please note that only 2-4 drops of lubricating oil need to be added each time.

a) Suggestions

Use walking pad less than 3 hours per week, to lubricate once every 5 months.

Use walking pad 4-7 hours per week, to lubricate once every 2 months.

Use walking pad more than 7 hours per week, to lubricate once a month.

It's important to avoid over-lubrication, as more lubricant doesn't necessarily mean better performance. Remember that reasonable lubrication is a key factor in extending the lifespan of your walking pad.

b) Lubrication method

The lubrication method is shown in the figure. Lift the middle of the running belt with your hands, and then squeeze the lubricant between the running deck and the running belt.

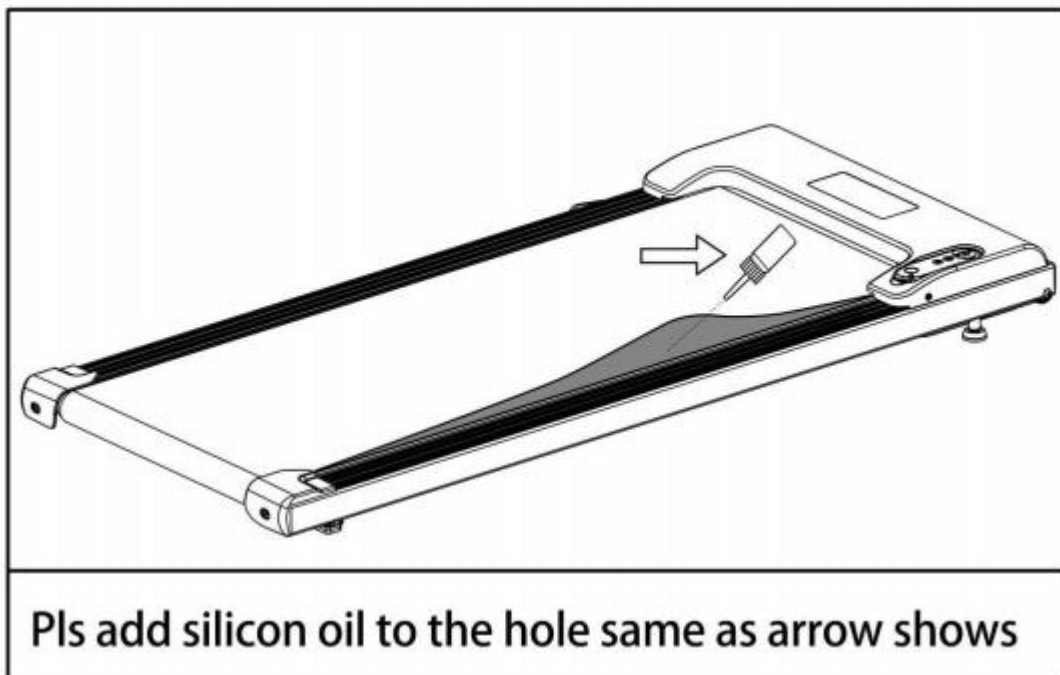

Exercise Guidelines

Warm-up: It is necessary to do 5 to 10 minutes of warm-up exercise before each use of the machine.

Breathing: Breathing cannot be blocked during exercise. It is recommended to inhale through the nose and exhale through the mouth while coordinating with the action. If breathing becomes too fast, stop exercising immediately.

Frequency: It is important to give a 24-hour rest period for the same muscle group before exercising again.

Load: Determine the amount of training based on individual physical training state and practice according to the principle of progressive load. Muscle soreness during initial training is normal and will disappear with continued training.

Diet: Exercise one hour after a meal to protect the digestive system. Wait at least half an hour after training before eating. It is recommended to drink less water during exercise and avoid drinking too much to prevent an increase in the burden on the heart and kidneys.

Stretching: It is recommended to stretch before exercising. Warm muscles are easier to stretch.

So walk for 5-10 minutes to warm up first. Stop and do stretching exercises 5 times, holding each leg for at least 10 seconds each time. Repeat the stretching exercises after the workout.

Suggested Stretches

1. Stretch Down

Bend your knees slightly, and slowly bend your body down, letting your back and shoulders relax and try to touch your toes with your hands. Hold for 10-15 seconds, then relax. Repeat 3 times (picture 1)



2. Hamstring Stretch

Sit on a clean seat cushion and straighten one leg. Put the other leg in so that it fits against the inside of the straightened leg. Measure with your hands and touch your toes as much as possible. Hold for 10-15 seconds, then relax. Repeat 3 times for each leg. (picture 2)



3. Calf and Achilles Tendon Stretches

Stand with two hands against a wall or tree, one foot behind. Keep your hind legs upright and land on your heels and lean toward the wall or tree. Hold for 10-15 seconds, then relax. Repeat 3 times for each leg. (Picture 3)

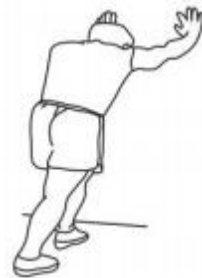

4. Ankle Stretch

Hold the balance with your left hand against the wall or table, then stretch your right hand back. Grab the toe of your right toe and slowly pull toward your buttocks until you feel the muscles on the face are very tense. Hold for 10-15 seconds, then relax. Repeat 3 times for each leg.(Picture 4)



5. Stretch Sartorius (inner thigh muscle)

Sit with your feet facing each other and your knees facing out. Grab both feet with both hands toward the abdomen and pull in the direction of the ditch. Hold for 10-15 seconds, then relax. Repeat 3 times for each leg (Picture 5)



FCC Statement:

This device complies with part 15 of the FCC Rules. Operation is subject to the following two conditions:

- (1) This device may not cause harmful interference, and
- (2) this device must accept any interference received, including interference that may cause undesired operation.

This equipment has been tested and found to comply with the limits for a Class B digital device, pursuant to part 15 of the FCC Rules. These limits are designed to provide reasonable protection against harmful interference in a residential installation. This equipment generates, uses and can radiate radio frequency energy and, if not installed and used in accordance with the instructions, may cause harmful interference to radio communications. However, there is no guarantee that interference will not occur in a particular installation. If this equipment does cause harmful interference to radio or television reception, which can be determined by turning the equipment off and on, the user is encouraged to try to correct the interference by one or more of the following measures:

- Reorient or relocate the receiving antenna.
- Increase the separation between the equipment and receiver.
- Connect the equipment into an outlet on a circuit different from that to which the receiver is connected.
- Consult the dealer or an experienced radio/TV technician for help.

Caution: Any changes or modifications not expressly approved by the party responsible for compliance could void the user's authority to operate the equipment.

This equipment complies with FCC radiation exposure limits set forth for an uncontrolled environment. This transmitter must not be co-located or operating in conjunction with any other antenna or transmitter.

RF exposure warning:

This equipment complies with radiation exposure limits set forth for an uncontrolled environment. This equipment should be installed and operated with Minimum distance 20cm between the radiator and your body.