

# VEVOR<sup>®</sup>

## TOUGH TOOLS, HALF PRICE

Technical Support and E-Warranty Certificate  
[www.vevor.com/support](http://www.vevor.com/support)

## **Moveable Welding Table USER MANUAL**

We continue to be committed to provide you tools with competitive price. "Save Half", "Half Price" or any other similar expressions used by us only represents an estimate of savings you might benefit from buying certain tools with us compared to the major top brands and does not necessarily mean to cover all categories of tools offered by us. You are kindly reminded to verify carefully when you are placing an order with us if you are actually saving half in comparison with the top major brands.

Model: WT600

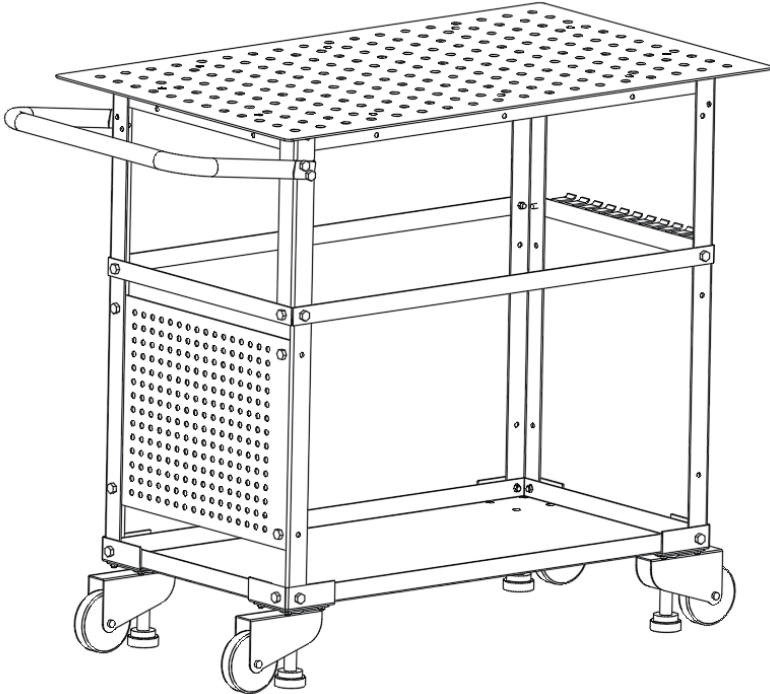

Note: the quantity of parts shown in the manual is the actual usage and the unused parts are spare parts.

### NEED HELP? CONTACT US!

Have product questions? Need technical support? Please feel free to contact us:

✉ [CustomerService@vevor.com](mailto:CustomerService@vevor.com)

This is the original instruction, please read all manual instructions carefully before operating. VEVOR reserves clear interpretation of our user manual. The appearance of the product shall be subject to the product you received. Please forgive us that we won't inform you again if there is any technology or software updates on our product.

## ASSEMBLY PRECAUTIONS

1. Assemble only according to these instructions. Incorrect assembly can be a hazard.
2. Wear safety goggles and heavy-duty work gloves during assembly.
3. Do not assemble when tired or when under the influence of alcohol, drugs or medication.
4. Weight capacity and other product capabilities apply to properly and completely assembled product only.





## USE PRECAUTIONS



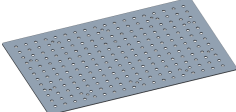
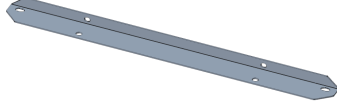

1. This product is not a toy. Do not allow children to play with or approach this item.
2. Use as intended only. Do not sit or stand on table.
3. Inspect before every use. Do not use if parts are loose or damaged.
4. Use only on flat, level, hard surface.
5. Do not exceed listed weight capacity. Tighten all knobs securely before applying load.  
Be aware of dynamic loading! Sudden load movement may briefly create excess load causing product failure.
6. The maximum load of the product is 600 lb (272 Kg).

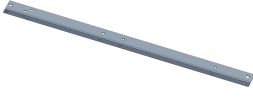
## ASSEMBLY INSTRUCTIONS

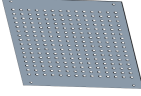
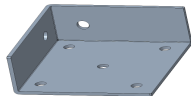
For additional information regarding the parts listed in the following pages, refer to the Assembly Diagram of this manual. Unwrap and separate all parts on a clear work area.

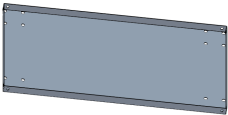
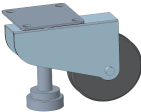
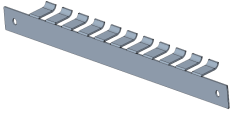
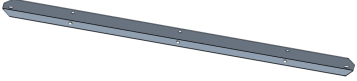
## PACKAGE CONTENTS

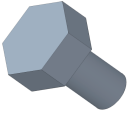
 <p>1. Table Top × 1</p>	 <p>2. Plate 1 × 2</p>
 <p>3. Handle × 1</p>	 <p>4. Table leg × 4</p>
 <p>5. Plate 2 × 2</p>	 <p>6. Plate 3 × 1</p>
 <p>7. Front plate × 1</p>	 <p>8. Wheel support × 4</p>

 <p>9. Tool palette × 1</p>	 <p>10. Casters Wheel × 4</p>		
 <p>11. Couple plate × 1</p>	 <p>12. Plate 4 × 2</p>		
 <p>13. M8 Nut × 58</p>	 <p>14. M8x20 Screw × 32</p>	 <p>15. M8x15 Grub screw × 10</p>	 <p>16. M8x12 Round head screw × 16</p>

## ASSEMBLY STEPS

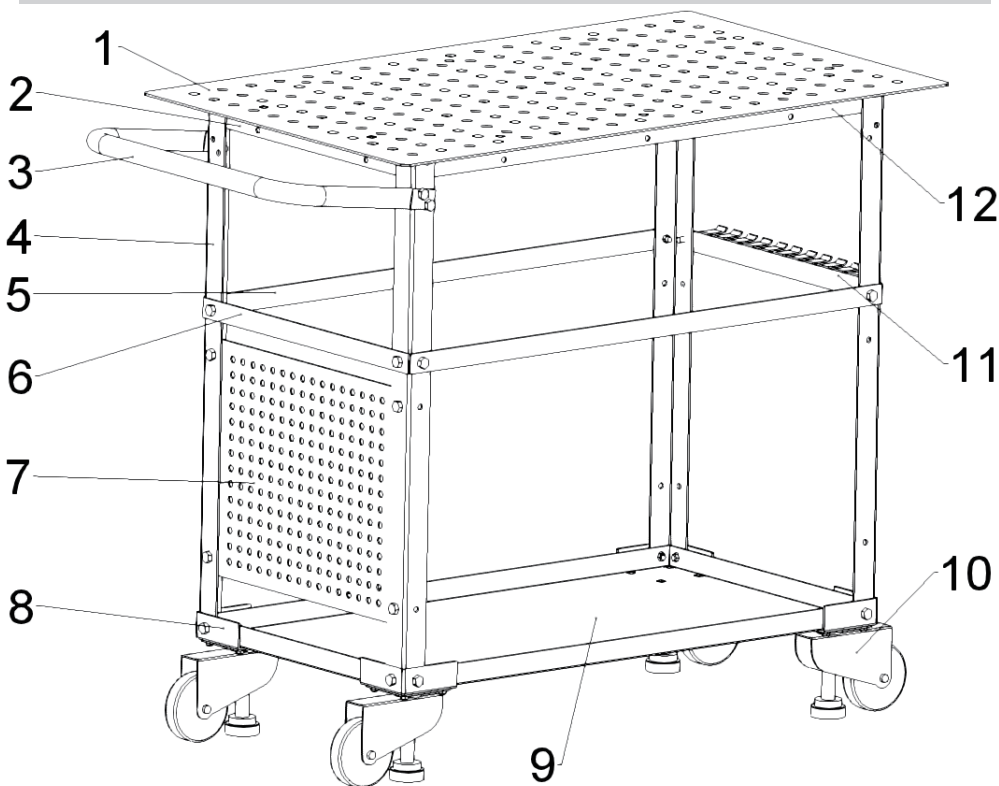

# STEP 1

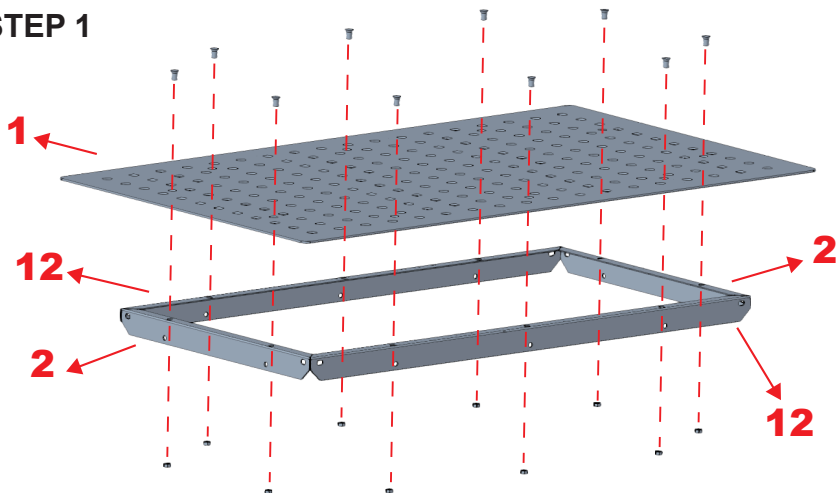

Component 1

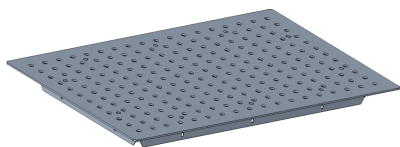

15  × 10

13  × 10

# STEP 2

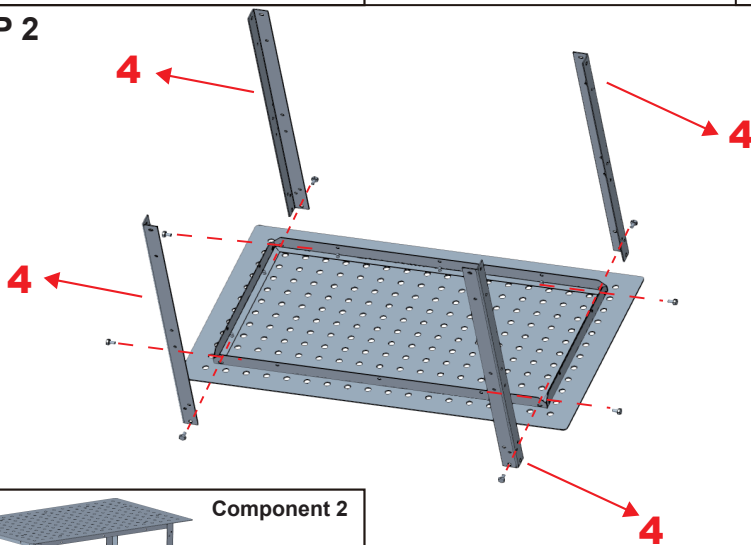

Component 2



14  × 8

13  × 8

### STEP 3

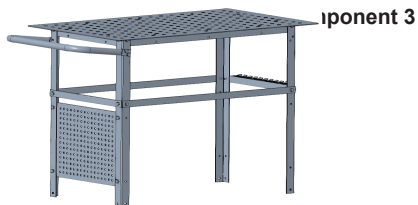
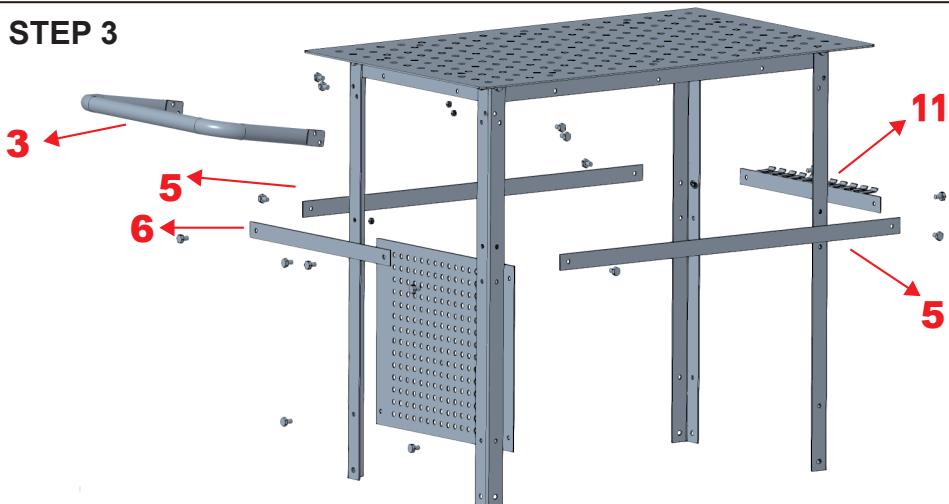



**NOTE: Each screw is locked with a nut.**

14		× 16
13		× 16

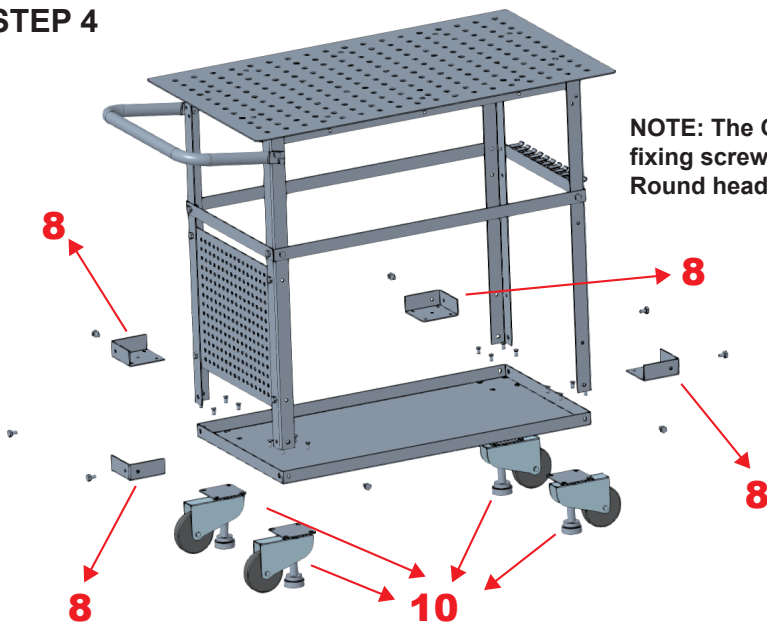
### STEP 4



**NOTE: The Casters Wheel fixing screws are M8x12 Round head screw.**

14		× 8
13		× 8
16		× 16

**Complete your product.**



**VEVOR<sup>®</sup>**

**TOUGH TOOLS, HALF PRICE**

**Technical Support and E-Warranty Certificate**

**[www.vevor.com/support](http://www.vevor.com/support)**

**Made In China**

# VEVOR<sup>®</sup>

## TOUGH TOOLS, HALF PRICE

Assistance technique et certificat de garantie  
électronique [www.vevor.com/support](http://www.vevor.com/support)

## Table de soudage mobile MANUEL D'UTILISATION

Nous continuons à nous engager à vous fournir des outils à des prix compétitifs. « Économisez la moitié », « Moitié prix » ou toute autre expression similaire utilisée par nous ne représente qu'une estimation des économies que vous pourriez réaliser en achetant certains outils chez nous par rapport aux grandes marques et ne couvre pas nécessairement toutes les catégories d'outils que nous proposons. Nous vous rappelons de bien vouloir vérifier soigneusement lorsque vous passez une commande chez nous si vous économisez réellement la moitié par rapport aux grandes marques.

**VEVOR**<sup>®</sup>  
TOUGH TOOLS, HALF PRICE

## Table de soudage mobile

INSTRUCTIONS D'INSTALLATION

Modèle : WT600

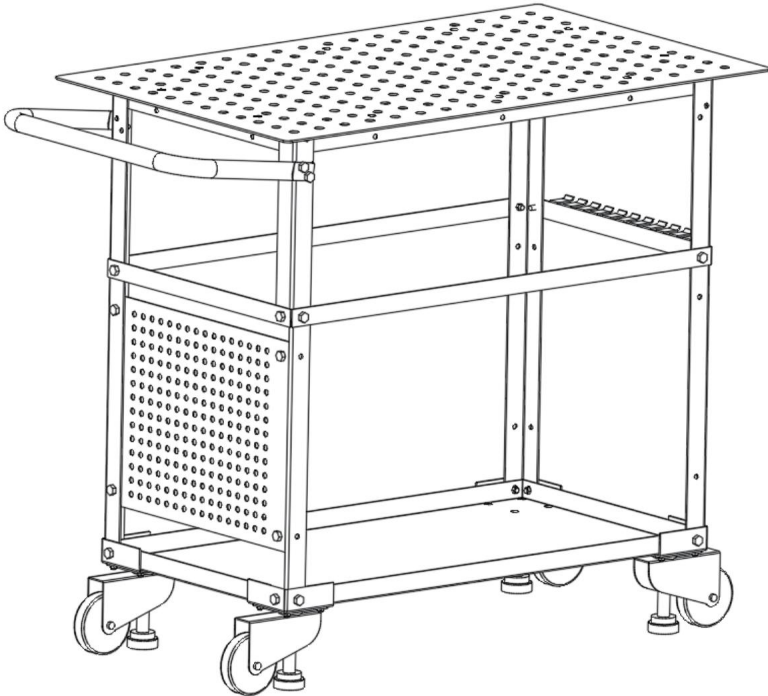

Remarque : la quantité de pièces indiquée dans le manuel correspond à l'utilisation réelle et les pièces non utilisées sont des pièces de rechange.

### BESOIN D'AIDE? CONTACTEZ-NOUS!

Vous avez des questions sur les produits ? Vous avez besoin d'une assistance technique ? N'hésitez pas



à nous contacter : [CustomerService@vevor.com](mailto:CustomerService@vevor.com)

Il s'agit des instructions d'origine, veuillez lire attentivement toutes les instructions du manuel avant de l'utiliser.

VEVOR se réserve le droit d'interpréter clairement notre manuel d'utilisation. L'apparence du produit dépend du produit que vous avez reçu. Veuillez nous excuser, nous ne vous informerons plus si des mises à jour technologiques ou logicielles sont disponibles sur notre produit.

## PRÉCAUTIONS D'ASSEMBLAGE

1. Assemblez uniquement en suivant ces instructions. Un assemblage incorrect peut être dangereux.
2. Portez des lunettes de sécurité et des gants de travail résistants pendant l'assemblage.
3. Ne montez pas lorsque vous êtes fatigué ou sous l'influence de l'alcool, de drogues ou de médicaments.
4. La capacité de poids et les autres capacités du produit s'appliquent aux produits correctement et complètement assemblés, produit uniquement.







## PRÉCAUTIONS D'EMPLOI

1. Ce produit n'est pas un jouet. Ne laissez pas les enfants jouer avec ou s'en approcher.
2. Utiliser uniquement comme prévu. Ne pas s'asseoir ou se tenir debout sur la table.
3. Inspectez l'appareil avant chaque utilisation. N'utilisez pas l'appareil si certaines pièces sont desserrées ou endommagées.
4. Utiliser uniquement sur une surface plane, horizontale et dure.
5. Ne pas dépasser la capacité de poids indiquée. Bien serrer tous les boutons avant d'appliquer la charge.  
Soyez attentif aux charges dynamiques ! Un mouvement de charge soudain peut brièvement créer une charge excessive entraînant une défaillance du produit.
6. La charge maximale du produit est de 600 lb (272 kg).

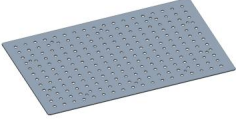
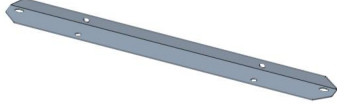
## INSTRUCTIONS DE MONTAGE

Pour plus d'informations sur les pièces répertoriées dans les pages suivantes, reportez-vous au schéma d'assemblage de ce manuel. Déballez et séparez toutes les pièces sur une zone de travail dégagée.

## CONTENU DU COLIS

 <p>1. Plateau de table × 1</p>	 <p>2. Planche 1 × 2</p>
 <p>3. Poignée × 1</p>	 <p>4. Pied de table × 4</p>
 <p>5. Plaque 2 × 2</p>	 <p>6. Plaque 3 × 1</p>
 <p>7. Plaque avant × 1</p>	 <p>8. Support de roue × 4</p>

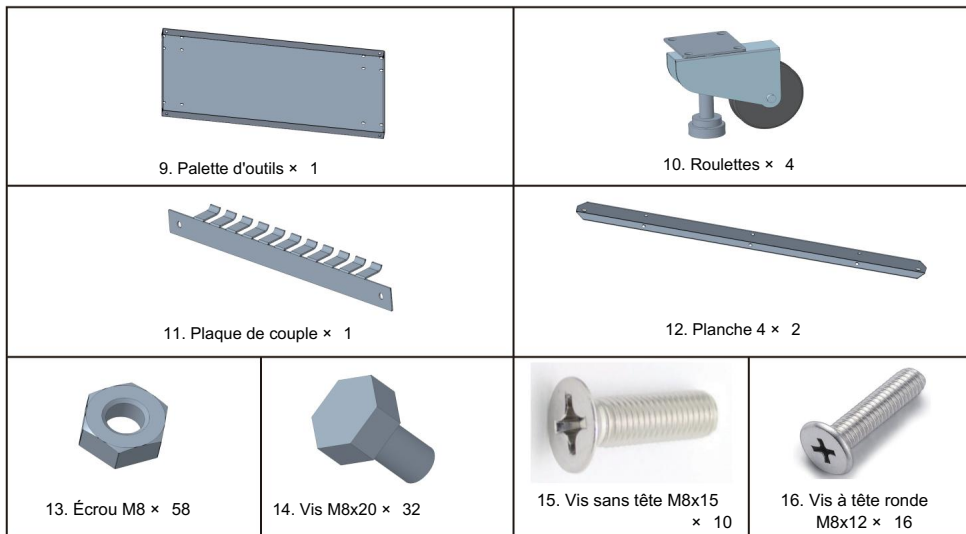

## ÉTAPES D'ASSEMBLAGE

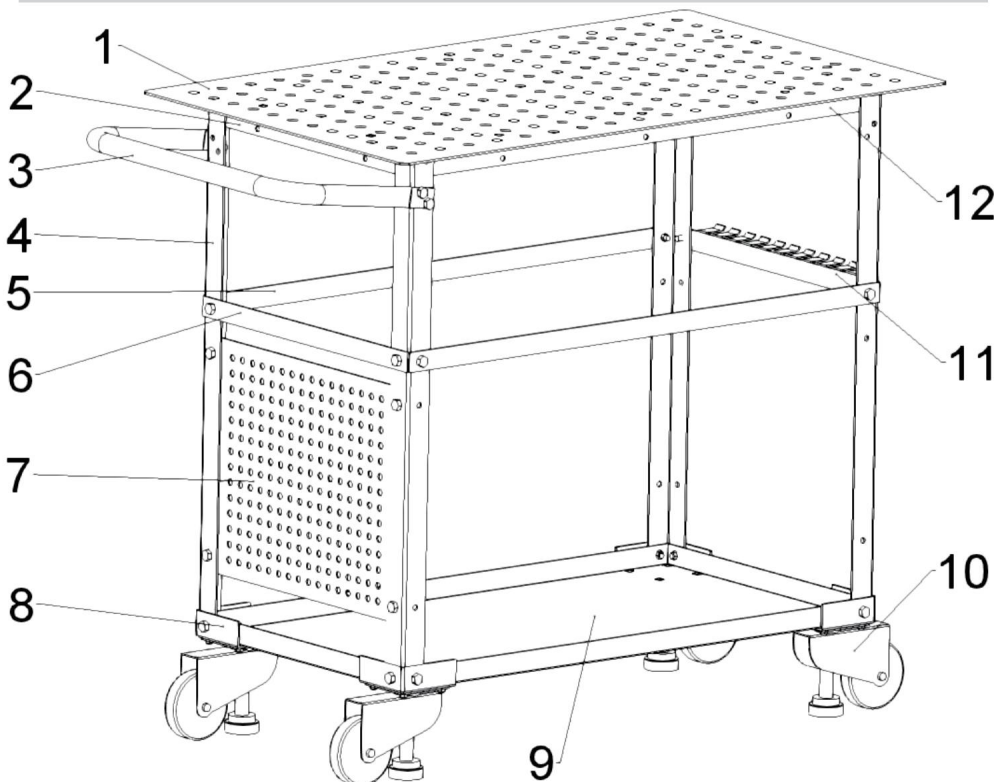

### ÉTAPE 1

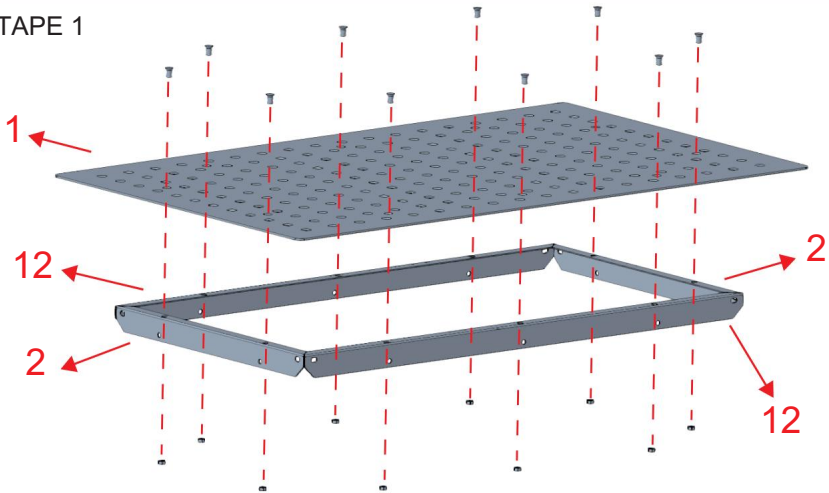

Composante 1



15  × 10

13  × 10

### ÉTAPE 2

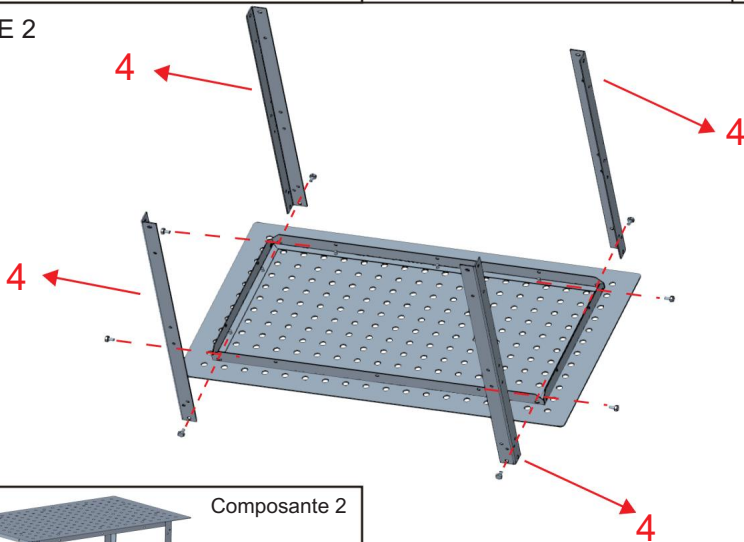

Composante 2



14  × 8

13  × 8

### ÉTAPE 3

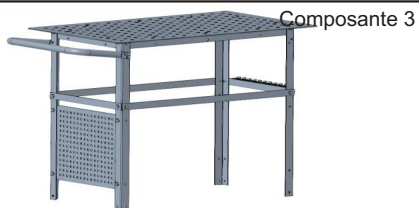
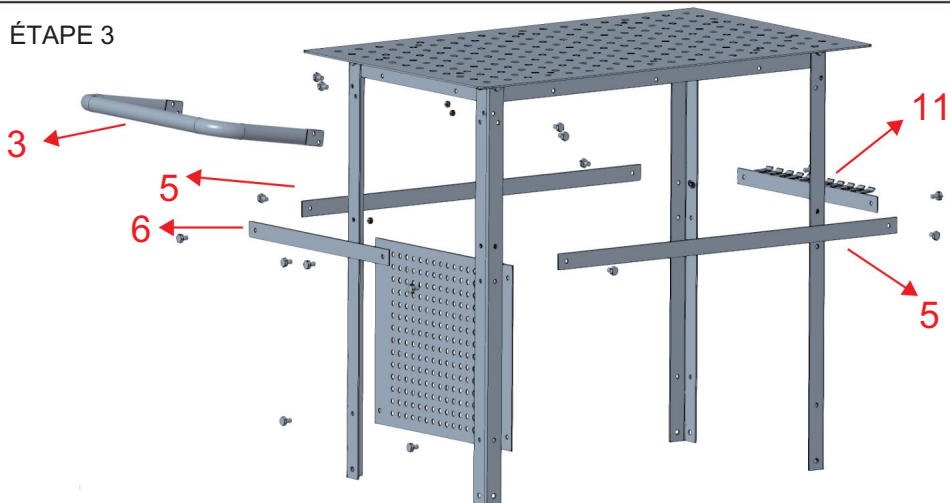

REMARQUE : Chaque vis est verrouillée avec un écrou.

14		× 16
13		× 16

### ÉTAPE 4

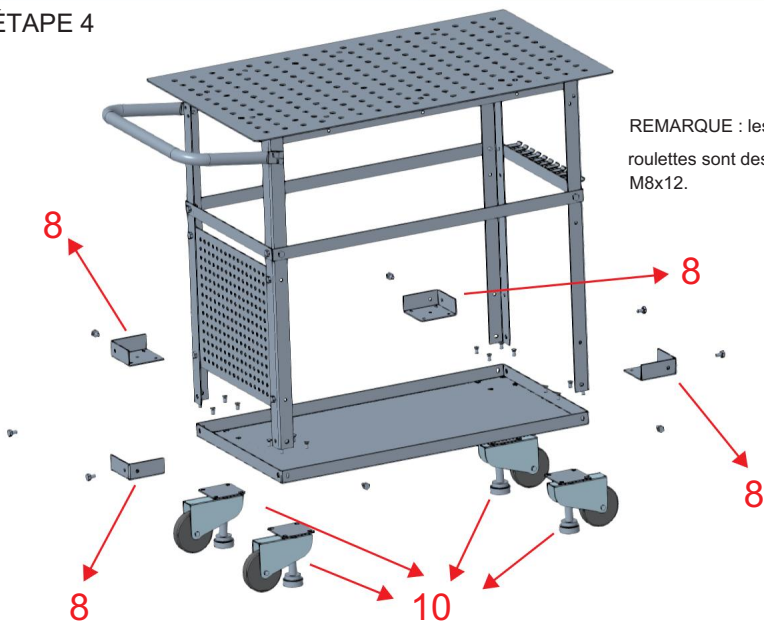

REMARQUE : les vis de fixation des roulettes sont des vis à tête ronde M8x12.

14		× 8
13		× 8
16		× 16

Complétez votre produit.



**VEVOR<sup>®</sup>**

**TOUGH TOOLS, HALF PRICE**

Assistance technique et certificat de garantie électronique

[www.vevor.com/support](http://www.vevor.com/support)

Fabriqué en Chine

# VEVOR®

## TOUGH TOOLS, HALF PRICE

Technischer Support und E-Garantie-Zertifikat  
[www.vevor.com/support](http://www.vevor.com/support)

## Beweglicher Schweißstisch BENUTZERHANDBUCH

Wir sind weiterhin bestrebt, Ihnen Werkzeuge zu wettbewerbsfähigen Preisen anzubieten. „Sparen Sie die Hälfte“, „Halber Preis“ oder andere ähnliche Ausdrücke, die wir verwenden, stellen nur eine Schätzung der Ersparnis dar, die Sie beim Kauf bestimmter Werkzeuge bei uns im Vergleich zu den großen Topmarken erzielen können, und bedeuten nicht unbedingt, dass sie alle von uns angebotenen Werkzeugkategorien abdecken. Wir möchten Sie freundlich daran erinnern, bei Ihrer Bestellung bei uns sorgfältig zu prüfen, ob Sie im Vergleich zu den großen Topmarken tatsächlich die Hälfte sparen.

**VEVOR**<sup>®</sup>  
TOUGH TOOLS, HALF PRICE

# Beweglicher Schweißstisch

## INSTALLATIONSANLEITUNG

Modell: WT600

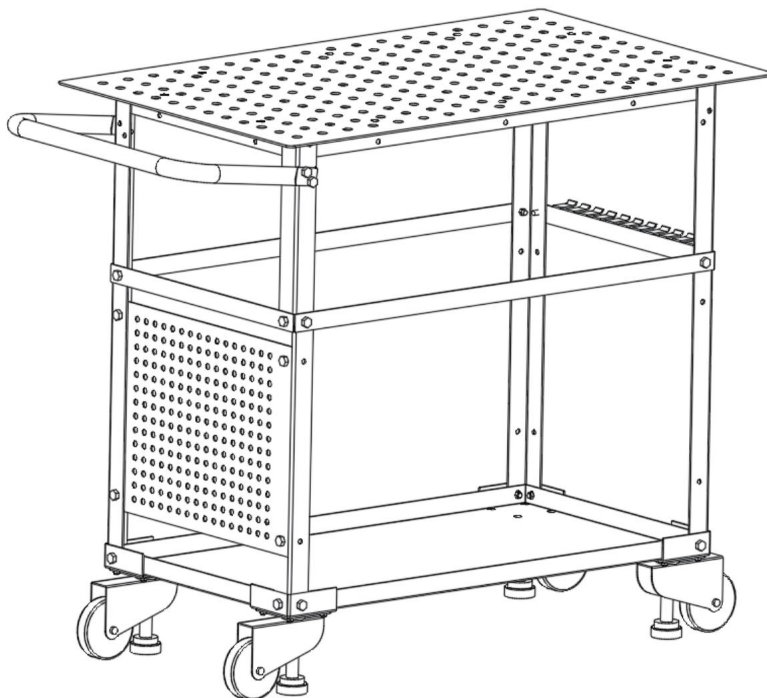

Hinweis: Die in der Anleitung angegebene Teilmenge entspricht der tatsächlichen Nutzung und die nicht verwendeten Teile sind Ersatzteile.

### Brauchen Sie Hilfe? Kontaktieren Sie uns!

Haben Sie Fragen zum Produkt? Benötigen Sie technischen Support? Kontaktieren Sie



uns gerne: [CustomerService@vevor.com](mailto:CustomerService@vevor.com)

Dies ist die Originalanleitung. Lesen Sie vor der Inbetriebnahme bitte alle Anweisungen im Handbuch sorgfältig durch. VEVOR behält sich die genaue Auslegung unseres Benutzerhandbuchs vor. Das Erscheinungsbild des Produkts richtet sich nach dem Produkt, das Sie erhalten haben. Bitte verzeihen Sie uns, dass wir Sie nicht erneut informieren, wenn es Technologie- oder Software-Updates für unser Produkt gibt.

## VORSICHTSMASSNAHMEN BEI DER MONTAGE

1. Bauen Sie das Gerät nur gemäß dieser Anleitung zusammen. Eine falsche Montage kann gefährlich sein.
2. Tragen Sie während der Montage eine Schutzbrille und strapazierfähige Arbeitshandschuhe.
3. Nicht montieren, wenn Sie müde sind oder unter dem Einfluss von Alkohol, Drogen oder Medikamenten stehen.
4. Die Gewichtskapazität und andere Produkteigenschaften gelten für ordnungsgemäß und vollständig montierte nur Produkt.







## VORSICHTSMASSNAHMEN BEIM GEBRAUCH



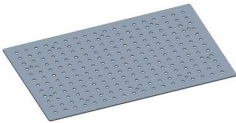
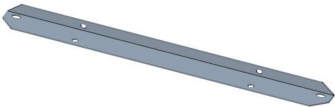

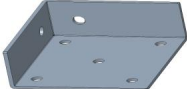

1. Dieses Produkt ist kein Spielzeug. Erlauben Sie Kindern nicht, mit diesem Produkt zu spielen oder sich ihm zu nähern.
2. Nur bestimmungsgemäß verwenden. Nicht auf dem Tisch sitzen oder stehen.
3. Vor jedem Gebrauch überprüfen. Nicht verwenden, wenn Teile lose oder beschädigt sind.
4. Nur auf flachen, ebenen und harten Oberflächen verwenden.
5. Die angegebene Gewichtskapazität darf nicht überschritten werden. Ziehen Sie alle Knöpfe fest an, bevor Sie eine Last aufbringen.  
Achten Sie auf dynamische Belastungen! Plötzliche Lastbewegungen können kurzzeitig zu einer Überlastung und damit zu Produktversagen führen.
6. Die maximale Belastung des Produkts beträgt 600 lb (272 kg).

## MONTAGEANLEITUNG

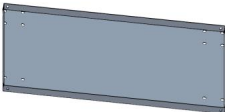
Weitere Informationen zu den auf den folgenden Seiten aufgeführten Teilen finden Sie im Montageprogramm dieses Handbuchs. Packen Sie alle Teile auf einem freien Arbeitsbereich aus und trennen Sie sie voneinander.

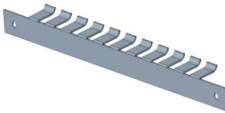
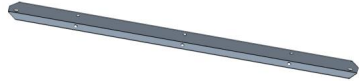
## PACKUNGSGEHALT

 <p>1. Tischplatte x 1</p>	 <p>2. Platte 1 x 2</p>
 <p>3. Griff x 1</p>	 <p>4. Tischbein x 4</p>
 <p>5. Platte 2 x 2</p>	 <p>6. Platte 3 x 1</p>
 <p>7. Frontplatte x 1</p>	 <p>8. Radunterstützung x 4</p>

 <p>9. Werkzeugpalette x 1</p>	 <p>10. Lenkrollen x 4</p>		
 <p>11. Paarplatte x 1</p>	 <p>12. Platte 4 x 2</p>		
 <p>13. M8 Mutter x 58</p>	 <p>14. M8x20 Schraube x 32</p>	 <p>15. M8x15 Madenschraube x 10</p>	 <p>16. M8x12 Rundkopfschraube x 16</p>

## MONTAGEANLEITUNG

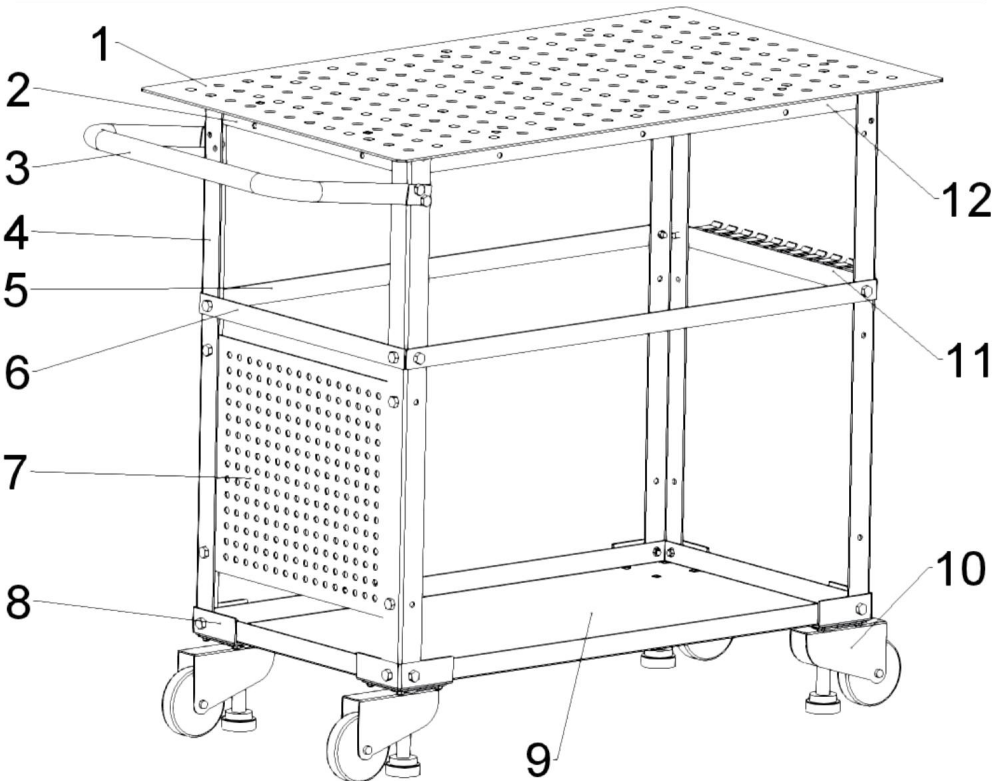

### SCHRITT 1

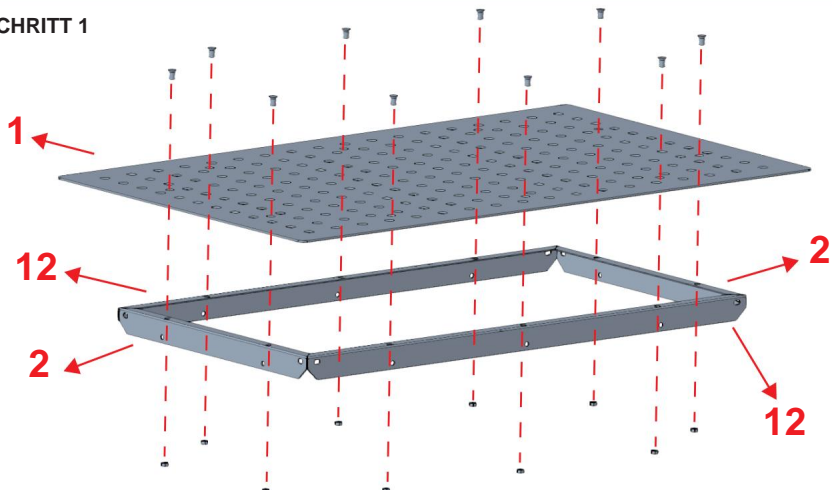

Komponente 1



15  x 10

13  x 10

### SCHRITT 2

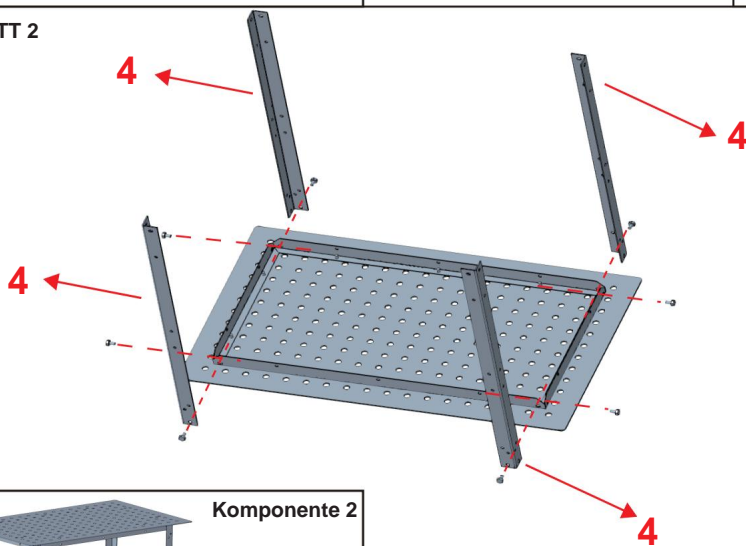

Komponente 2



14  x 8

13  x 8

### SCHRITT 3

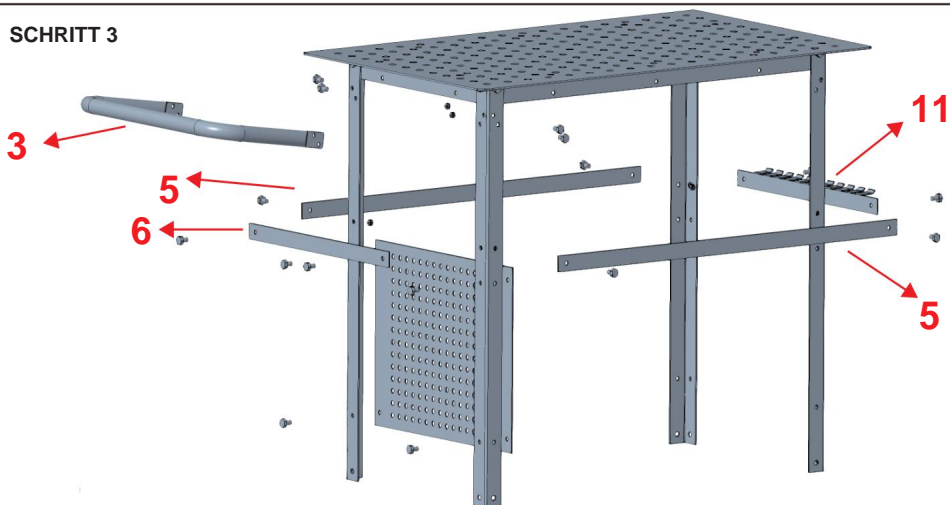

HINWEIS: Jede Schraube ist mit einer Mutter gesichert.

14  x 16

13  x 16

### SCHRITT 4

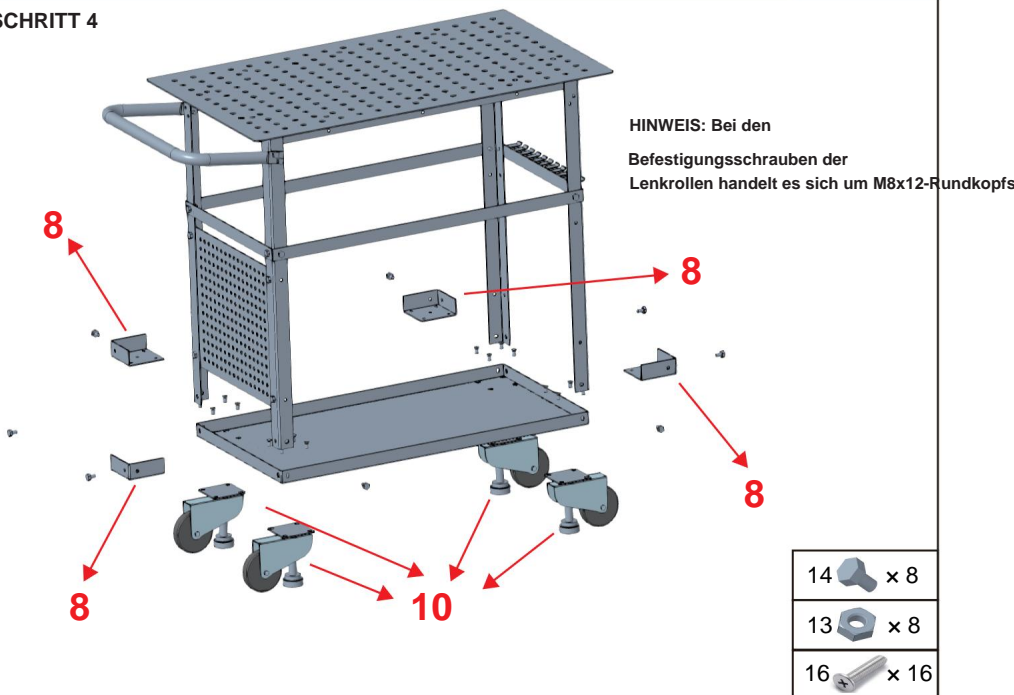

HINWEIS: Bei den Befestigungsschrauben der Lenkrollen handelt es sich um M8x12-Rundkopfs

14  x 8

13  x 8

16  x 16

**Vervollständigen Sie Ihr Produkt.**



**VEVOR<sup>®</sup>**

**TOUGH TOOLS, HALF PRICE**

**Technischer Support und E-Garantie-Zertifikat**

**[www.vevor.com/support](http://www.vevor.com/support)**

**In China hergestellt**

# VEVOR<sup>®</sup>

## TOUGH TOOLS, HALF PRICE

Supporto tecnico e certificato di garanzia  
elettronica [www.vevor.com/support](http://www.vevor.com/support)

## Tavolo di saldatura mobile MANUALE D'USO

Continuiamo a impegnarci per fornirvi strumenti a prezzi competitivi. "Risparmia la metà", "Metà prezzo" o qualsiasi altra espressione simile da noi utilizzata rappresenta solo una stima del risparmio che potresti ottenere acquistando determinati utensili con noi rispetto ai principali marchi principali e non necessariamente intende coprire tutte le categorie di utensili da noi offerti. Ti ricordiamo cortesemente di verificare attentamente quando effettui un ordine con noi se stai effettivamente risparmiando la metà rispetto ai principali marchi principali.

**VEVOR**<sup>®</sup>  
TOUGH TOOLS, HALF PRICE

## Tavolo di saldatura mobile

ISTRUZIONI PER L'INSTALLAZIONE

Modello: WT600

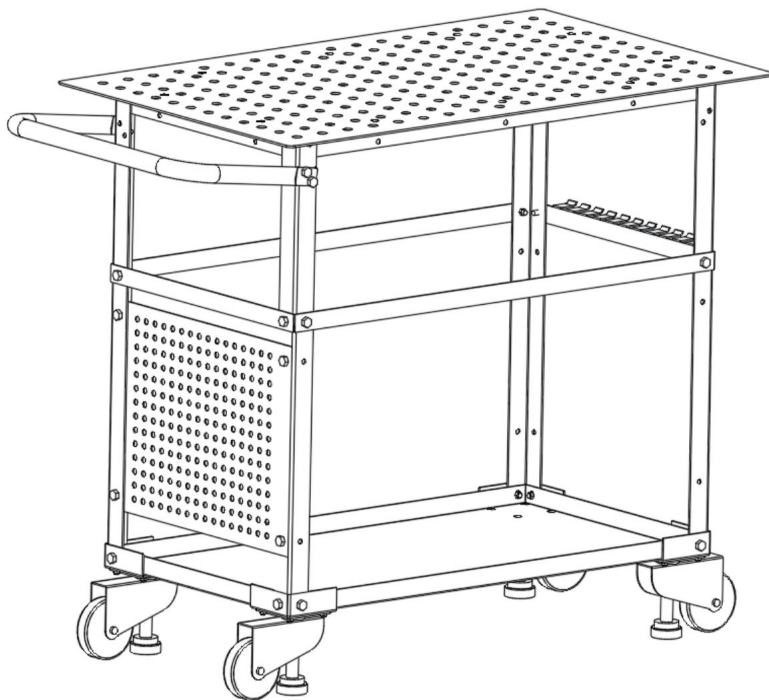

Nota: la quantità di parti indicata nel manuale corrisponde all'uso effettivo e le parti non utilizzate sono pezzi di ricambio.

### HAI BISOGNO DI AIUTO? CONTATTACI!

Hai domande sul prodotto? Hai bisogno di supporto tecnico? Non esitare a

✉ contattarci: [CustomerService@vevor.com](mailto:CustomerService@vevor.com)

Queste sono le istruzioni originali, leggere attentamente tutte le istruzioni del manuale prima di utilizzare il prodotto. VEVOR si riserva la chiara interpretazione del nostro manuale utente. L'aspetto del prodotto sarà soggetto al prodotto ricevuto. Vi preghiamo di perdonarci se non vi informeremo di nuovo se ci saranno aggiornamenti tecnologici o software sul nostro prodotto.

## PRECAUZIONI DI MONTAGGIO

1. Montare solo secondo queste istruzioni. Un montaggio non corretto può essere pericoloso.
2. Durante il montaggio, indossare occhiali protettivi e guanti da lavoro resistenti.
3. Non riunirsi quando si è stanchi o sotto l'effetto di alcol, droghe o farmaci.
4. La capacità di peso e le altre capacità del prodotto si applicano a prodotti correttamente e completamente assemblati solo prodotto.







## PRECAUZIONI D'USO

1. Questo prodotto non è un giocattolo. Non permettere ai bambini di giocare con questo articolo o di avvicinarsi ad esso.
2. Utilizzare solo come previsto. Non sedersi o stare in piedi sul tavolo.
3. Ispezionare prima di ogni utilizzo. Non utilizzare se le parti sono allentate o danneggiate.
4. Utilizzare solo su superfici piane, livellate e dure.
5. Non superare la capacità di peso indicata. Serrare saldamente tutte le manopole prima di applicare il carico.  
Siate consapevoli del carico dinamico! Un movimento improvviso del carico può creare brevemente un carico eccessivo, causando il guasto del prodotto.
6. Il carico massimo del prodotto è di 600 libbre (272 kg).

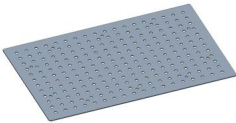
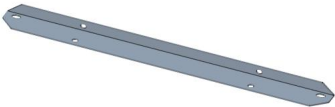
## ISTRUZIONI DI MONTAGGIO

Per ulteriori informazioni sulle parti elencate nelle pagine seguenti, fare riferimento allo schema di montaggio di questo manuale. Disimballare e separare tutte le parti su un'area di lavoro libera.

## CONTENUTO DELLA CONFEZIONE

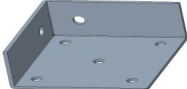
 1. Piano del tavolo x 1	 2. Piatto 1 x 2
 3. Maniglia x 1	 4. Gamba del tavolo x 4
 5. Piatto 2 x 2	 6. Piatto 3 x 1
 7. Piastra frontale x 1	 8. Supporto ruota x 4

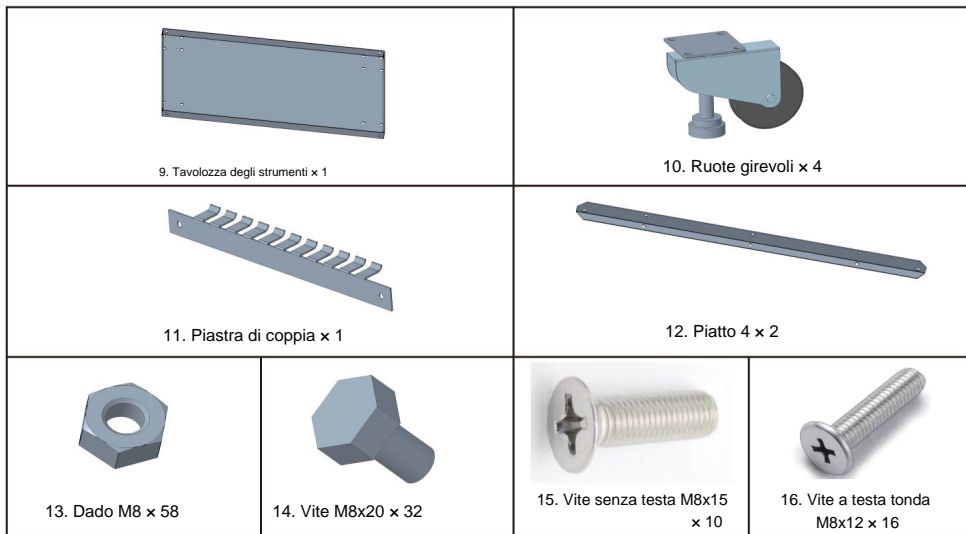

## FASI DI MONTAGGIO

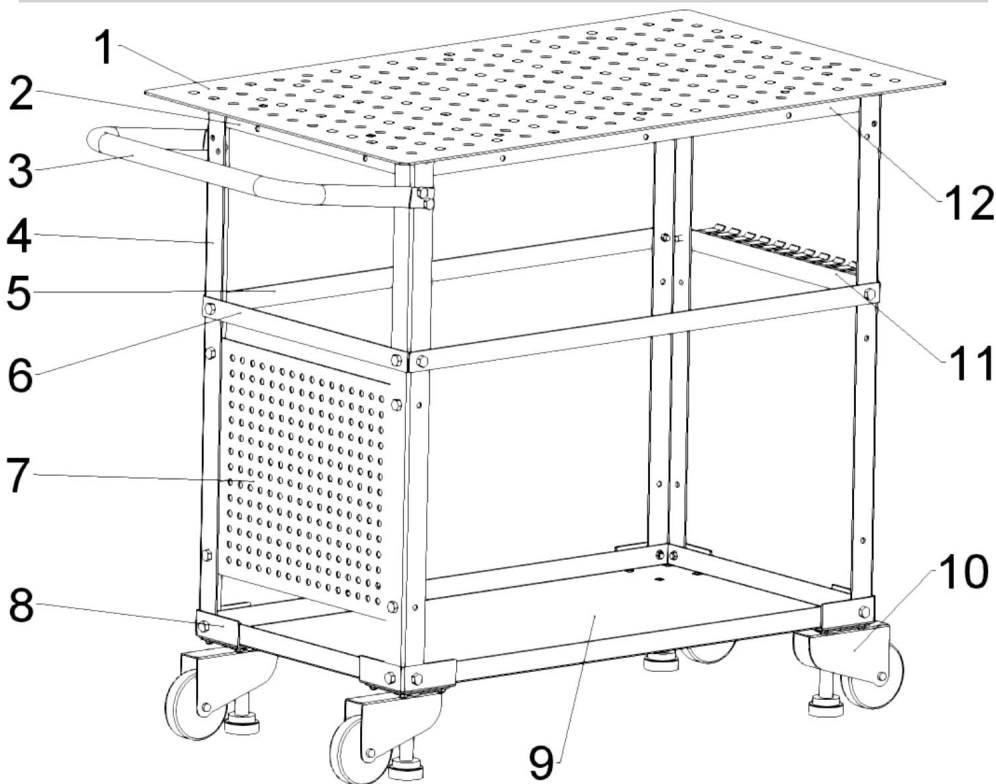

### PASSO 1

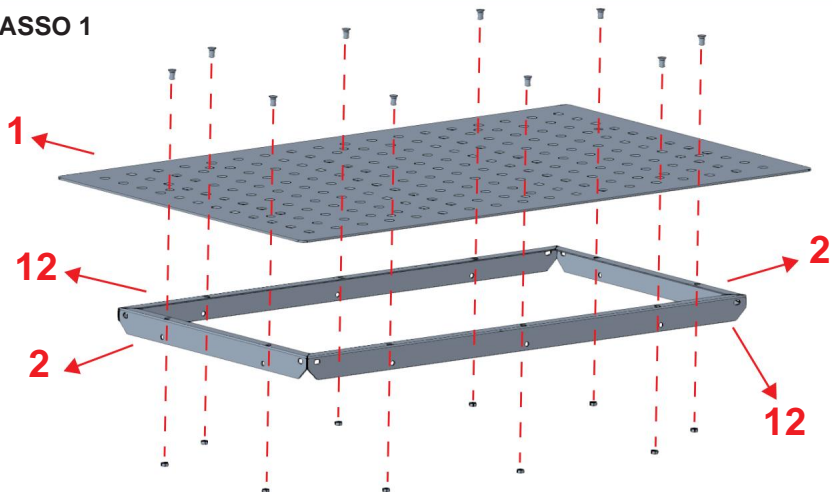

Componente 1



15  x 10

13  x 10

### PASSO 2

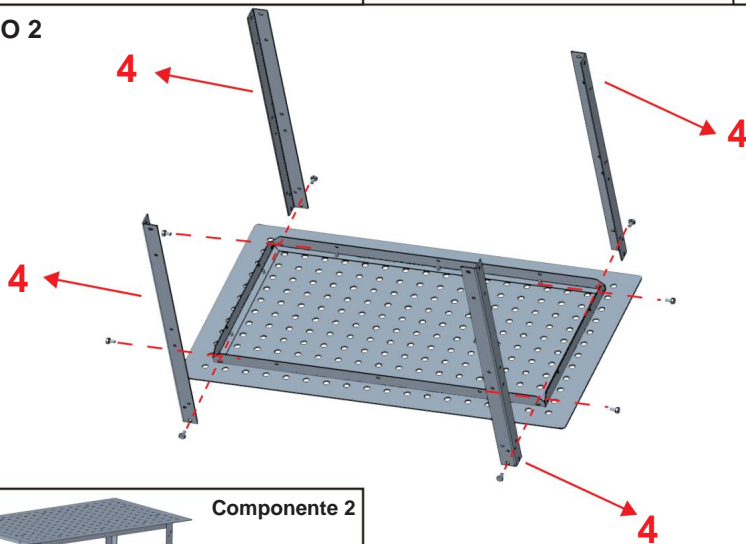

Componente 2



14  x 8

13  x 8

### PASSO 3

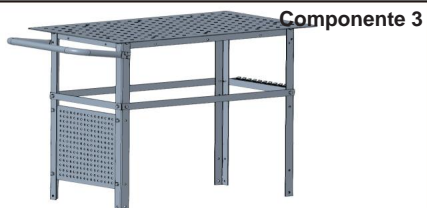
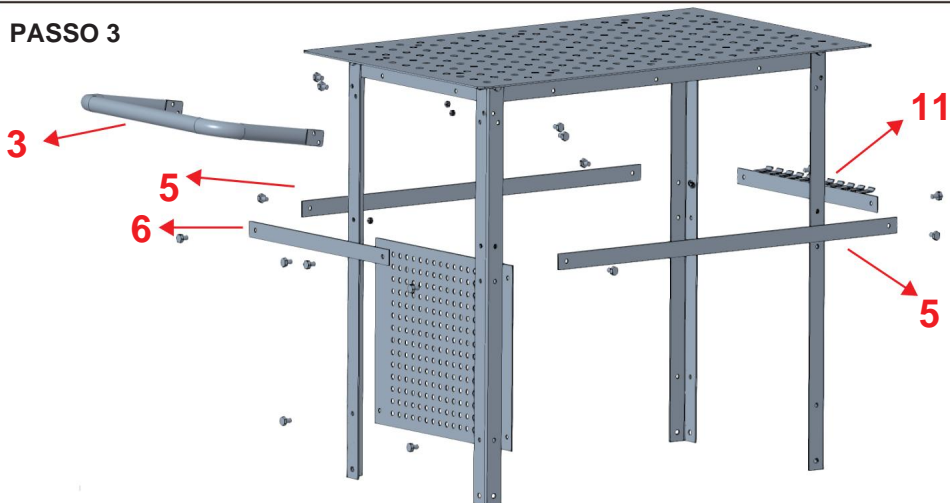

NOTA: Ogni vite è bloccata con un dado.

14  x 16

13  x 16

### PASSO 4

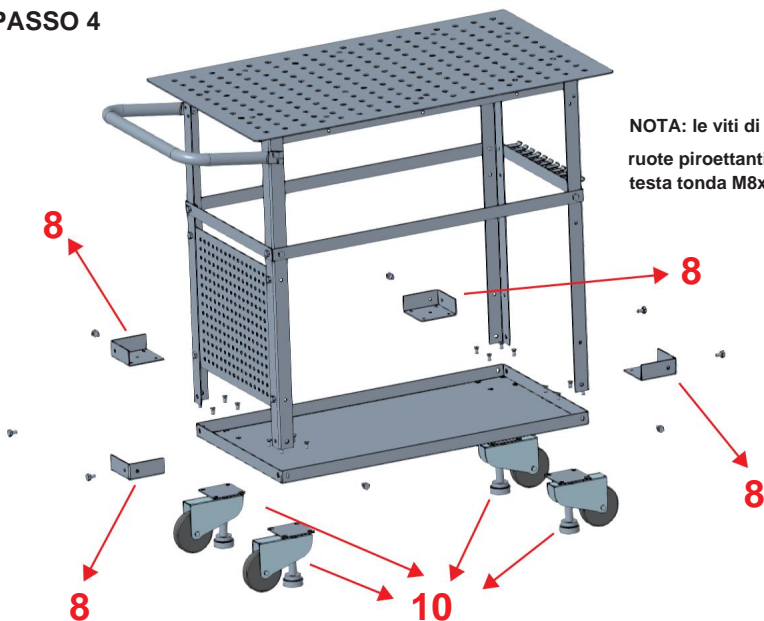

NOTA: le viti di fissaggio delle ruote piroettanti sono viti a testa tonda M8x12.

14  x 8

13  x 8

16  x 16

**Completa il tuo prodotto.**



**VEVOR<sup>®</sup>**

**TOUGH TOOLS, HALF PRICE**

**Supporto tecnico e certificato di garanzia  
elettronica [www.vevor.com/support](http://www.vevor.com/support)**

**Made in China**

# VEVOR®

## TOUGH TOOLS, HALF PRICE

Soporte técnico y certificado de garantía  
electrónica [www.vevor.com/support](http://www.vevor.com/support)

## Mesa de soldadura móvil

### MANUAL DEL USUARIO

Seguimos comprometidos a brindarle herramientas a precios competitivos. "Ahorre la mitad", "mitad de precio" o cualquier otra expresión similar que utilicemos solo representa una estimación del ahorro que podría obtener al comprar ciertas herramientas con nosotros en comparación con las principales marcas y no necesariamente significa que cubra todas las categorías de herramientas que ofrecemos. Le recordamos que, al realizar un pedido con nosotros, verifique cuidadosamente si realmente está ahorrando la mitad en comparación con las principales marcas.

**VEVOR**<sup>®</sup>  
TOUGH TOOLS, HALF PRICE

## Mesa de soldadura móvil

INSTRUCCIONES DE INSTALACIÓN

Modelo: WT600

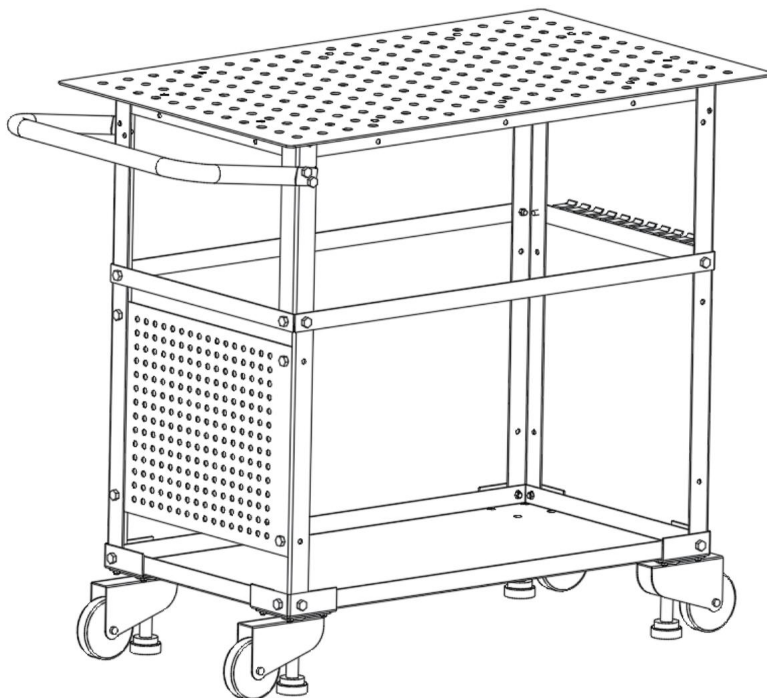

Nota: la cantidad de piezas que se muestra en el manual es el uso real y las piezas no utilizadas son piezas de repuesto.

**¿NECESITA AYUDA? ¡CONTÁCTENOS!**

¿Tiene preguntas sobre el producto? ¿Necesita asistencia técnica? No dude en ponerse en



contacto con nosotros: [CustomerService@vevor.com](mailto:CustomerService@vevor.com)

Estas son las instrucciones originales, lea atentamente todas las instrucciones del manual antes de operar. VEVOR se reserva el derecho de interpretar nuestro manual de usuario. La apariencia del producto dependerá del producto que haya recibido. Le rogamos que nos disculpe por no informarle nuevamente si hay actualizaciones tecnológicas o de software en nuestro producto.

## PRECAUCIONES DE MONTAJE

1. Realice el montaje únicamente de acuerdo con estas instrucciones. Un montaje incorrecto puede suponer un riesgo.
2. Use gafas de seguridad y guantes de trabajo resistentes durante el montaje.
3. No se reúna cuando esté cansado o bajo la influencia del alcohol, drogas o medicamentos.
4. La capacidad de peso y otras capacidades del producto se aplican a productos ensamblados de manera correcta y completa.  
Sólo producto.





## PRECAUCIONES DE USO





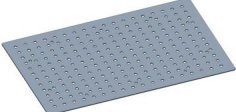
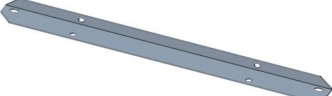

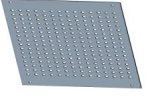
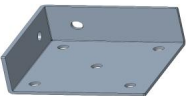

1. Este producto no es un juguete. No permita que los niños jueguen con este artículo ni se acerquen a él.
2. Utilícelo únicamente para el fin previsto. No se sienta ni se pare sobre una mesa.
3. Inspeccione el producto antes de cada uso. No lo utilice si hay piezas sueltas o dañadas.
4. Úselo únicamente en superficies planas, niveladas y duras.
5. No exceda la capacidad de peso indicada. Ajuste bien todas las perillas antes de aplicar la carga.  
¡Tenga cuidado con la carga dinámica! El movimiento repentino de la carga puede generar brevemente un exceso de carga que provoque la falla del producto.
6. La carga máxima del producto es de 600 lb (272 Kg).

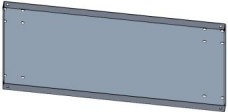
## INSTRUCCIONES DE MONTAJE

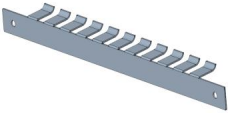
Para obtener información adicional sobre las piezas que se enumeran en las páginas siguientes, consulte el diagrama de ensamblaje de este manual. Desenvuelva y separe todas las piezas en un área de trabajo despejada.

## CONTENIDO DEL PAQUETE

 <p>1. Tablero de mesa × 1</p>	 <p>2. Placa 1 × 2</p>
 <p>3. Mango × 1</p>	 <p>4. Pata de mesa × 4</p>
 <p>5. Placa 2×2</p>	 <p>6. Plato 3×1</p>
 <p>7. Placa frontal × 1</p>	 <p>8. Soporte de rueda × 4</p>

 <p>9. Paleta de herramientas x 1</p>	 <p>10. Ruedas giratorias x 4</p>		
 <p>11. Placa de pareja x 1</p>	 <p>12. Placa 4x2</p>		
 <p>13. Tuerca M8 x 58</p>	 <p>14. Tornillo M8x20 x 32</p>	 <p>15. Tornillo prisionero M8x15 x 10</p>	 <p>16. Tornillo de cabeza redonda M8x12 x 16</p>

## PASOS DE MONTAJE

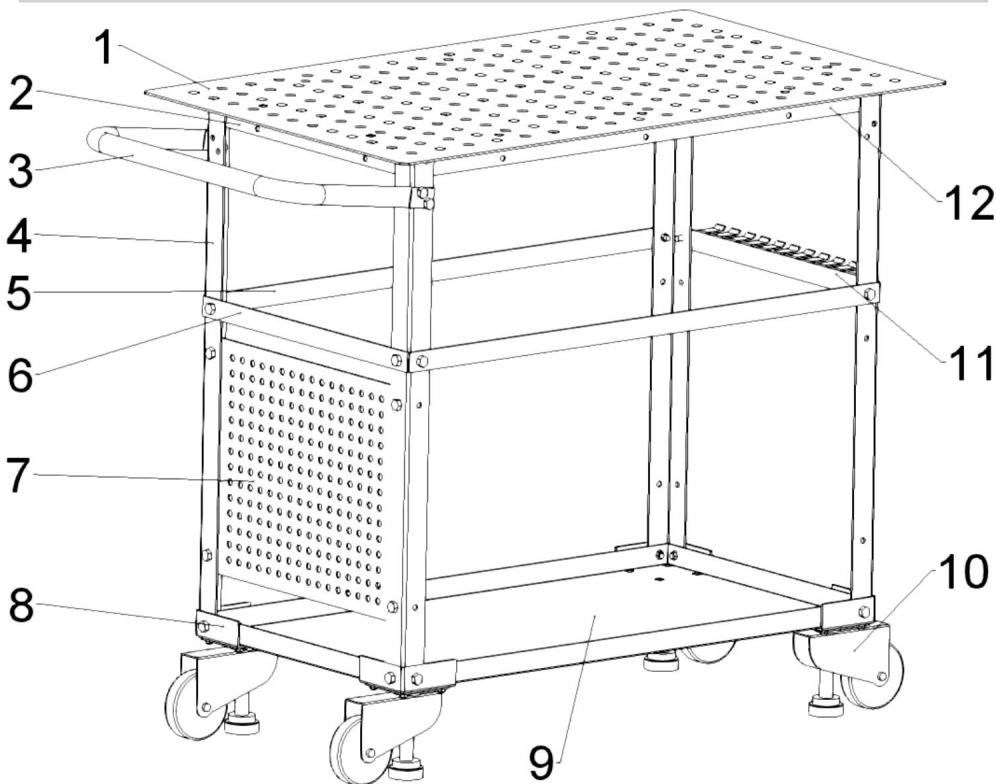

### PASO 1

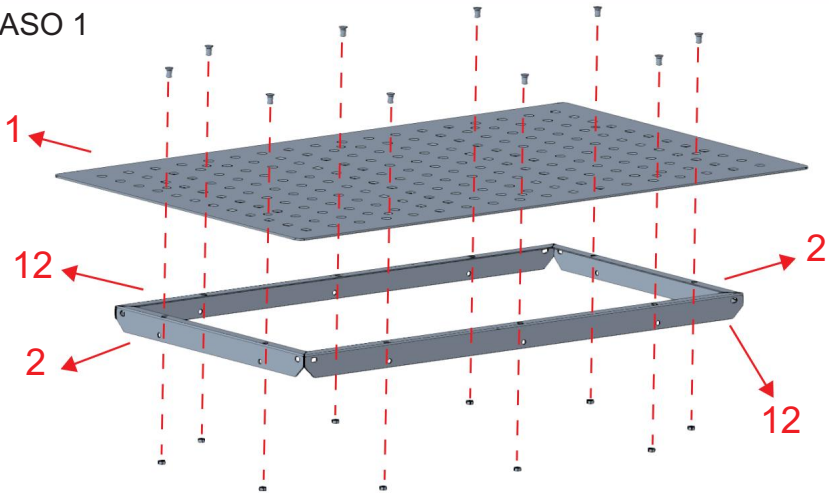

Componente 1



15  × 10

13  × 10

### PASO 2

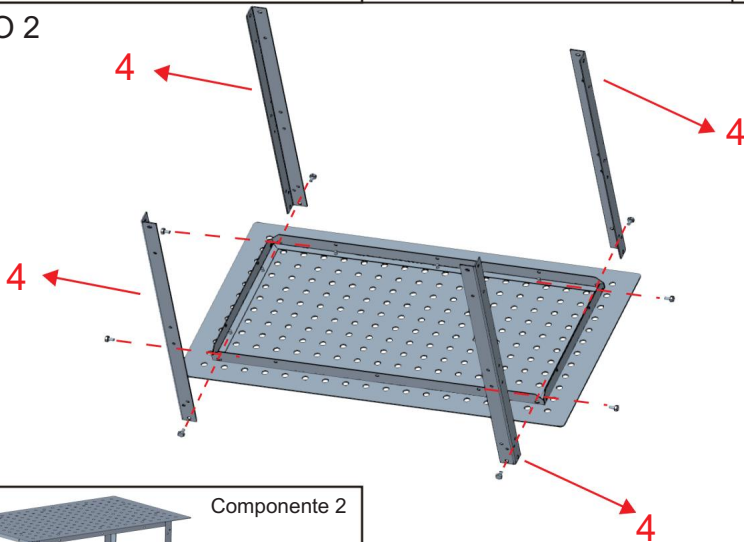

Componente 2



14  × 8

13  × 8

### PASO 3

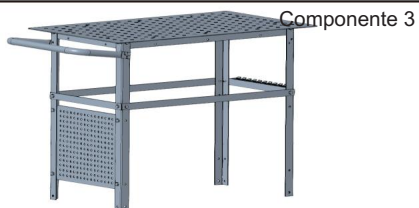
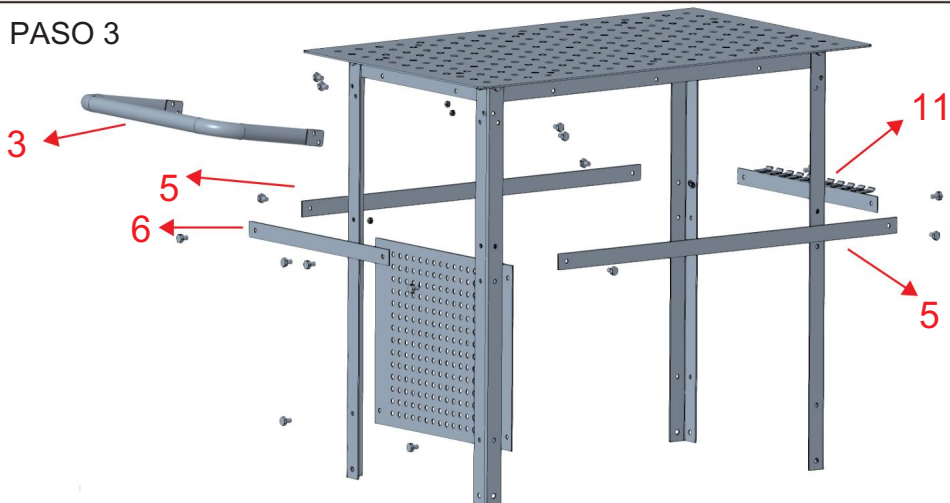

NOTA: Cada tornillo está bloqueado con una tuerca.

14  × 16

13  × 16

### PASO 4

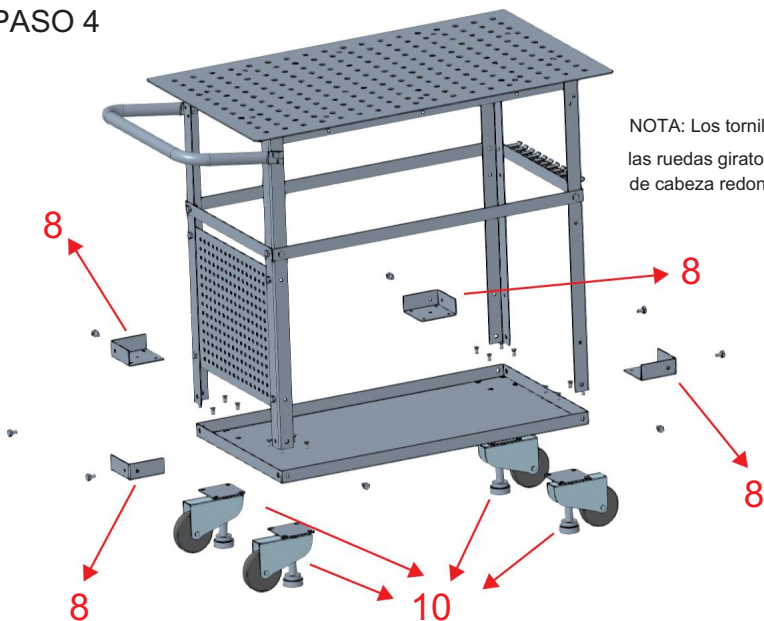

NOTA: Los tornillos de fijación de las ruedas giratorias son tornillos de cabeza redonda M8x12.

14  × 8

13  × 8

16  × 16

Completa tu producto.



**VEVOR<sup>®</sup>**

**TOUGH TOOLS, HALF PRICE**

Soporte técnico y certificado de garantía  
electrónica [www.vevor.com/support](http://www.vevor.com/support)

Hecho en china

# VEVOR®

## TOUGH TOOLS, HALF PRICE

Wsparcie techniczne i certyfikat gwarancji  
elektronicznej [www.vevor.com/support](http://www.vevor.com/support)

## Ruchomy stół spawalniczy INSTRUKCJA OBSŁUGI

Nadal staramy się oferować Państwu narzędzia w konkurencyjnych cenach. „Oszczędź połowę”, „Połowa ceny” lub inne podobne wyrażenia używane przez nas stanowią jedynie szacunkowe oszczędności, jakie możesz uzyskać kupując u nas określone narzędzia w porównaniu z głównymi markami i niekoniecznie oznaczają one objęcie wszystkich kategorii narzędzi oferowanych przez nas. Uprzejmie przypominamy, aby dokładnie sprawdzić, czy składając u nas zamówienie faktycznie oszczędzasz połowę w porównaniu z głównymi markami.

**VEVOR**<sup>®</sup>  
TOUGH TOOLS, HALF PRICE

## Ruchomy stół spawalniczy

INSTRUKCJA INSTALACJI

Model: WT600

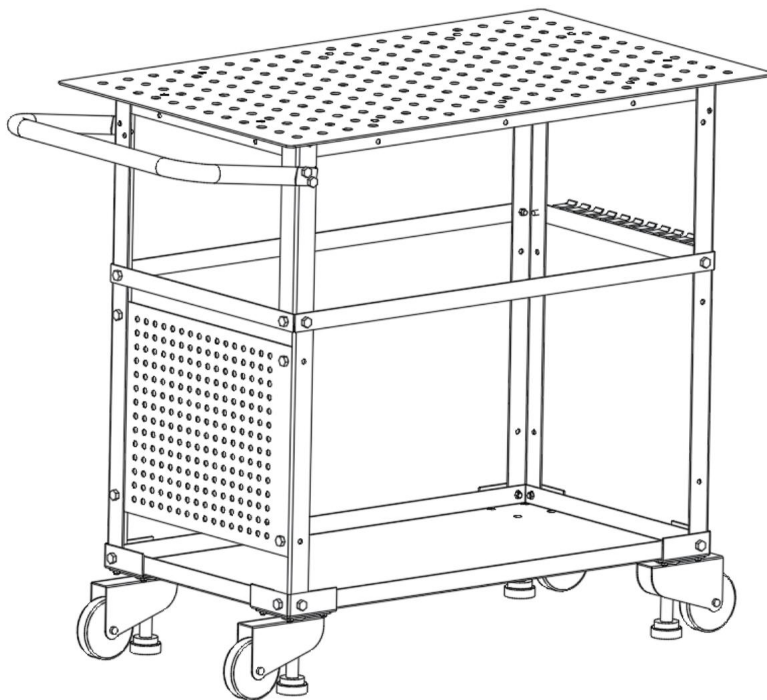

Uwaga: ilość części podana w instrukcji oznacza faktyczne zużycie, części nieużywane są częściami zamiennymi.

**POTRZEBUJESZ POMOCY? SKONTAKTUJ SIĘ Z NAMI!**

Masz pytania dotyczące produktu? Potrzebujesz wsparcia technicznego? Skontaktuj

✉ się z nami: [CustomerService@vevor.com](mailto:CustomerService@vevor.com)

To jest oryginalna instrukcja, przed rozpoczęciem użytkowania należy uważnie przeczytać wszystkie instrukcje. VEVOR zastrzega sobie prawo do jasnej interpretacji naszej instrukcji obsługi. Wygląd produktu będzie zależał od produktu, który otrzymałeś. Prosimy o wybaczenie, że nie poinformujemy Cię ponownie, jeśli w naszym produkcie pojawiają się jakiegokolwiek aktualizacje technologiczne lub oprogramowania.

## ŚRODKI OSTROŻNOŚCI PODCZAS MONTAŻU

1. Montaż należy wykonywać wyłącznie zgodnie z niniejszą instrukcją. Nieprawidłowy montaż może być niebezpieczny.
2. Podczas montażu należy nosić okulary ochronne i solidne rękawice robocze.
3. Nie przychodź na spotkania, jeśli jesteś zmęczony lub pod wpływem alkoholu, narkotyków lub leków.
4. Nośność i inne parametry produktu dotyczą produktu prawidłowo i całkowicie zmontowanego.  
tylko produkt.







## ŚRODKI OSTROŻNOŚCI



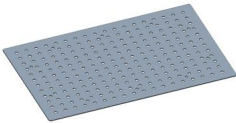
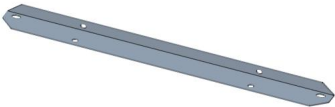

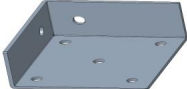

1. Ten produkt nie jest zabawką. Nie pozwalaj dzieciom bawić się tym przedmiotem ani zbliżać się do niego.
2. Używać wyłącznie zgodnie z przeznaczeniem. Nie siadać ani nie stawać na stole.
3. Przed każdym użyciem sprawdź. Nie używaj, jeśli części są luźne lub uszkodzone.
4. Stosować wyłącznie na płaskiej, równej i twardej powierzchni.
5. Nie przekraczaj podanego udźwigu. Przed zastosowaniem obciążenia dokręć mocno wszystkie pokręta.  
Należy pamiętać o dynamicznym obciążeniu! Nagły ruch obciążenia może chwilowo spowodować nadmierne obciążenie powodujące awarię produktu.
6. Maksymalne obciążenie produktu wynosi 600 funtów (272 kg).

## INSTRUKCJA MONTAŻU

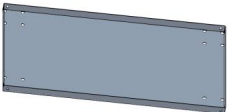
Aby uzyskać dodatkowe informacje dotyczące części wymienionych na kolejnych stronach, zapoznaj się ze schematem montażu w tym podręczniku. Rozpakuj i oddziel wszystkie części na czystym obszarze roboczym.

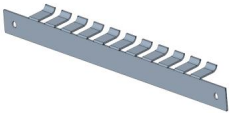
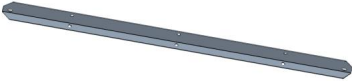
## ZAWARTOŚĆ OPAKOWANIA

 <p>1. Błat stołu × 1</p>	 <p>2. Talerz 1 × 2</p>
 <p>3. Uchwyt × 1</p>	 <p>4. Noga stołu × 4</p>
 <p>5. Talerz 2 × 2</p>	 <p>6. Talerz 3 × 1</p>
 <p>7. Płyta przednia × 1</p>	 <p>8. Podpora koła × 4</p>

 <p>9. Paleta narzędzi × 1</p>	 <p>10. Kółka × 4</p>		
 <p>11. Talerz parowy × 1</p>	 <p>12. Talerz 4 × 2</p>		
 <p>13. Nakrętka M8 × 58</p>	 <p>14. Śruba M8x20 × 32</p>	 <p>15. Śruba imbusowa M8x15 × 10</p>	 <p>16. Śruba z łbem okrągłym M8x12 × 16</p>

## KROKI MONTAŻU

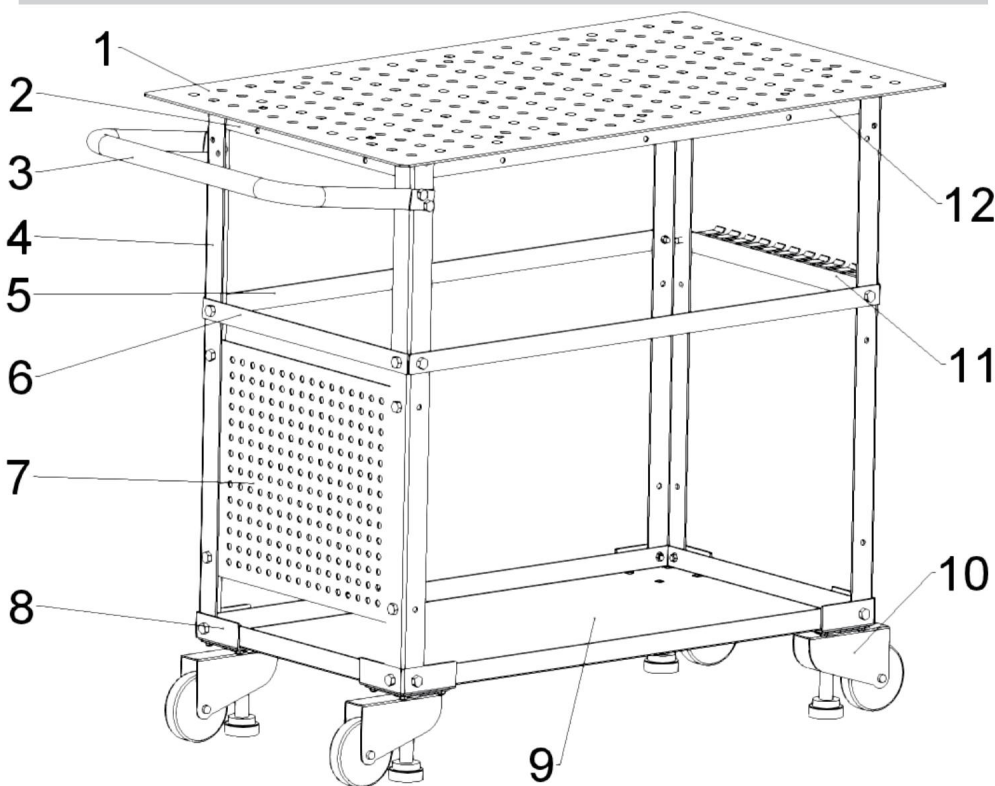

### KROK 1

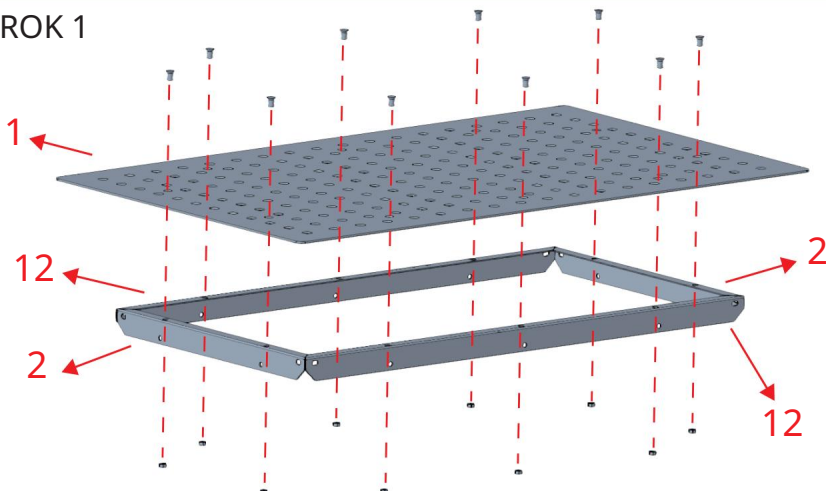

Składnik 1



15  ×10

13  ×10

### KROK 2

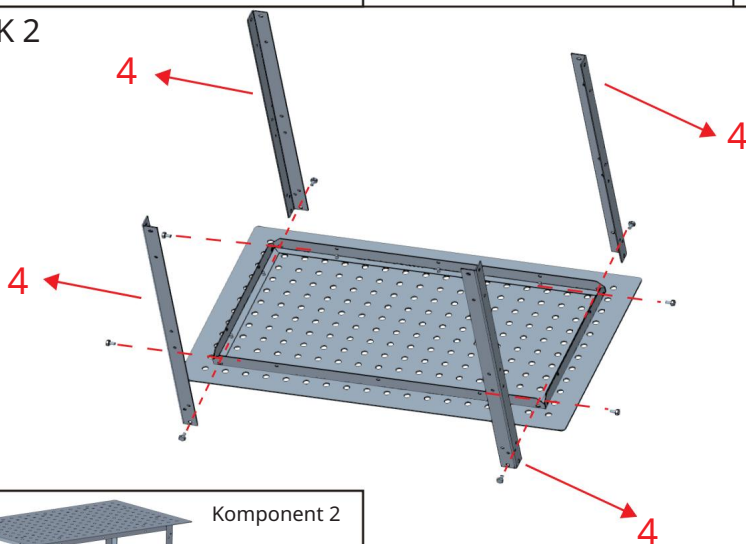

Komponent 2



14  ×8

13  ×8

### KROK 3

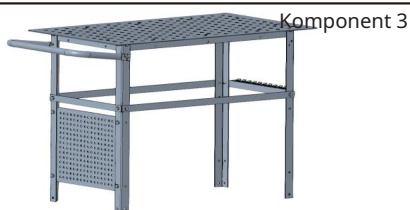
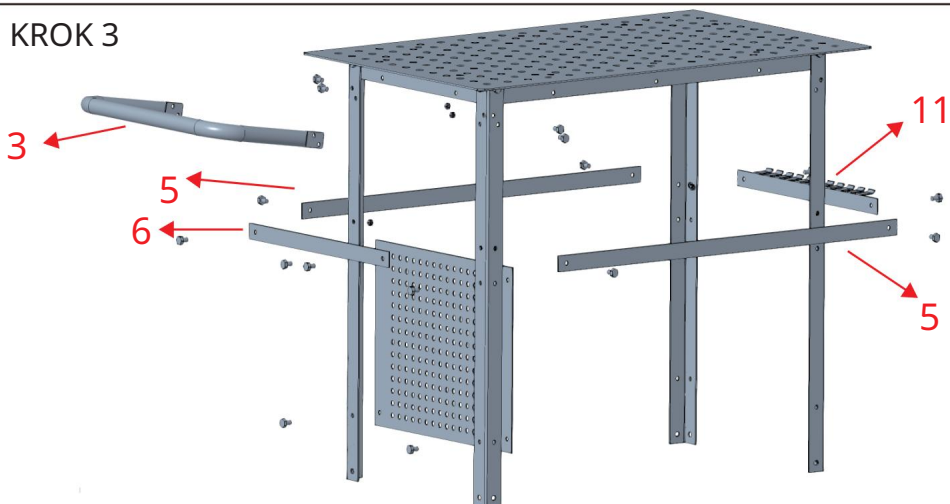

Komponent 3

UWAGA: Każda śruba jest zabezpieczona nakrętką.

14  ×16

13  ×16

### KROK 4

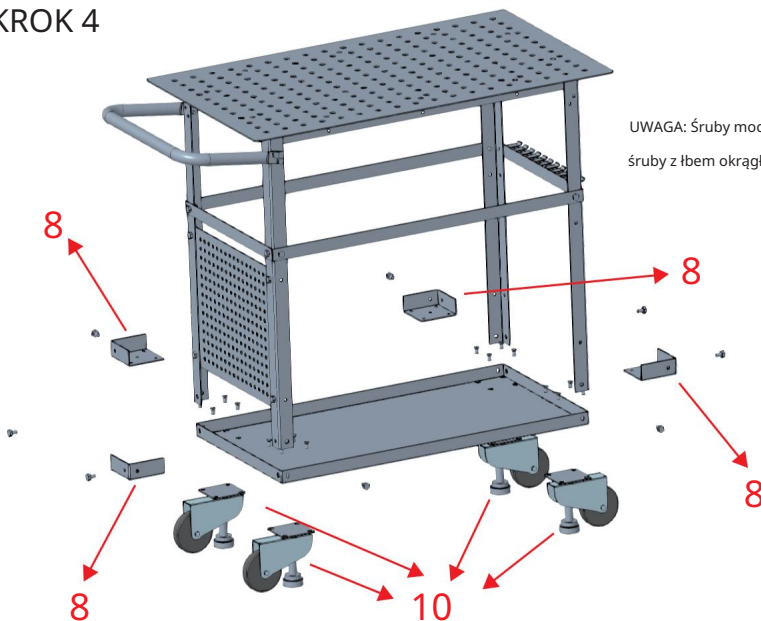

UWAGA: Śruby mocujące kółka jezdne to śruby z łbem okrągłym M8x12.

14  ×8

13  ×8

16  ×16

Uzupełnij swój produkt.



**VEVOR<sup>®</sup>**

**TOUGH TOOLS, HALF PRICE**

Wsparcie techniczne i certyfikat gwarancji elektronicznej

[www.vevor.com/support](http://www.vevor.com/support)

Wyprodukowano w Chinach

# VEVOR<sup>®</sup>

## TOUGH TOOLS, HALF PRICE

Technische ondersteuning en e-  
garantiecertificaat [www.vevor.com/support](http://www.vevor.com/support)

## Verplaatsbare lastafel

### GEBRUIKERSHANDLEIDING

Wij streven er voortdurend naar om u gereedschappen tegen concurrerende prijzen te leveren. "Bespaar de helft", "halve prijs" of andere soortgelijke uitdrukkingen die wij gebruiken, geven alleen een schatting van de besparingen die u kunt behalen door bepaalde gereedschappen bij ons te kopen in vergelijking met de grote topmerken en doseringen betekenen niet noodzakelijkerwijs dat ze alle categorieën gereedschappen dekken die wij aanbieden. Wij herinneren u eraan om zorgvuldig te controleren of u daadwerkelijk de helft bespaart in vergelijking met de grote topmerken wanneer u een bestelling bij ons plaatst.

**VEVOR**<sup>®</sup>  
TOUGH TOOLS, HALF PRICE

## Verplaatsbare lastafel

INSTALLATIE-INSTRUCTIES

Model: WT600

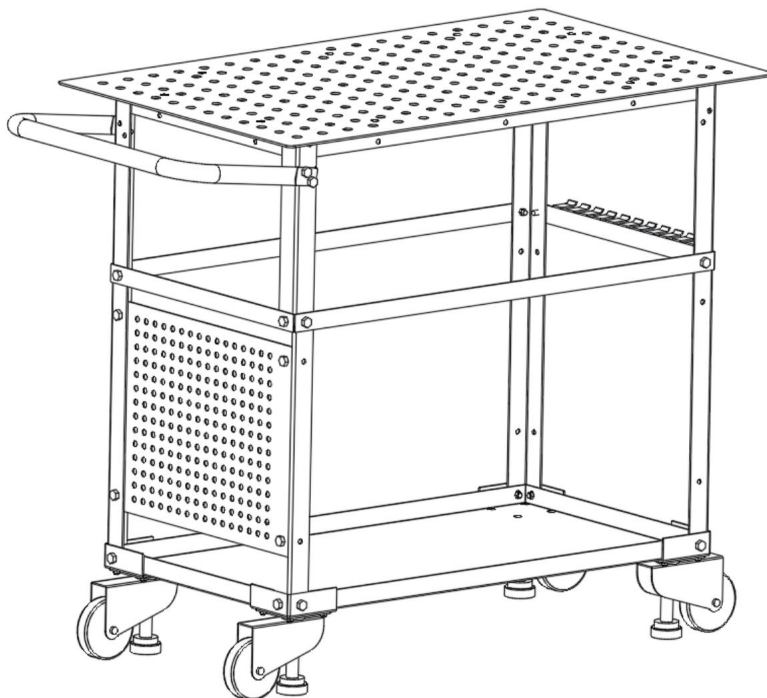

Let op: de in de handleiding vermelde hoeveelheid onderdelen is het daadwerkelijke gebruik. De ongebruikte onderdelen zijn reserveonderdelen.

### HULP NODIG? NEEM CONTACT MET ONS OP!

Heeft u vragen over het product? Heeft u technische ondersteuning nodig? Neem dan gerust



contact met ons op: [CustomerService@vevor.com](mailto:CustomerService@vevor.com)

Dit zijn de originele instructies. Lees de volledige handleiding zorgvuldig door voordat u het product gebruikt.

VEVOR behoudt zich een duidelijke interpretatie van onze gebruikershandleiding voor. Het uiterlijk van het product is afhankelijk van het product dat u hebt ontvangen. Vergeef ons dat we u niet opnieuw zullen informeren als er technologie- of software-updates voor ons product zijn.

## MONTAGEVOORZORGSMAATREGELEN

1. Monteer alleen volgens deze instructies. Onjuiste montage kan gevaarlijk zijn.
2. Draag tijdens de montage een veiligheidsbril en stevige werkhandschoenen.
3. Kom niet bijeen als u moe bent of onder invloed van alcohol, drugs of medicijnen.
4. Het draagvermogen en andere producteigenschappen zijn van toepassing op correct en volledig gemonteerde producten. alleen product.







## GEBRUIK VOORZORGSMAATREGELEN



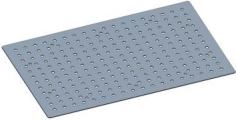
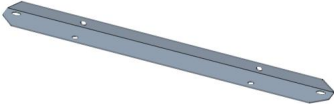



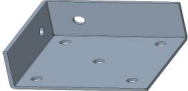

1. Dit product is geen speelgoed. Laat kinderen niet met dit item spelen of in de buurt ervan komen.
2. Gebruik alleen zoals bedoeld. Ga niet op de tafel zitten of staan.
3. Inspecteer voor elk gebruik. Niet gebruiken als onderdelen los of beschadigd zijn.
4. Alleen gebruiken op een vlakke, vlakke en harde ondergrond.
5. Overschrijd de vermelde gewichtscapaciteit niet. Draai alle knoppen stevig vast voordat u de belasting aanbrengt.  
Let op dynamische belasting! Plotselinge belastingbewegingen kunnen kortstondig overmatige belasting veroorzaken, waardoor het product kan falen.
6. De maximale belasting van het product bedraagt 600 lb (272 kg).

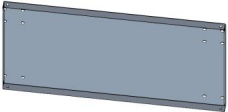
## MONTAGE-INSTRUCTIES

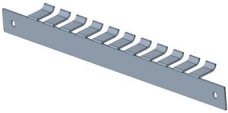
Voor aanvullende informatie over de onderdelen die op de volgende pagina's worden vermeld, raadpleegt u het montageschema van deze handleiding. Pak alle onderdelen uit en scheid ze op een leeg werkgebied.

## INHOUD VAN HET PAKKET

 <p>1. Tafelblad x 1</p>	 <p>2. Plaat 1 x 2</p>
 <p>3. Handvat x 1</p>	 <p>4. Tafelpoot x 4</p>
 <p>5. Plaat 2 x 2</p>	 <p>6. Plaat 3 x 1</p>
 <p>7. Frontplaat x 1</p>	 <p>8. Wielondersteuning x 4</p>

 <p>9. Gereedschappenpalet x 1</p>	 <p>10. Zwenkwielen x 4</p>		
 <p>11. Koppelplaat x 1</p>	 <p>12. Plaat 4 x 2</p>		
 <p>13. M8 moer x 58</p>	 <p>14. M8x20 Schroef x 32</p>	 <p>15. M8x15 Stelschroef x 10</p>	 <p>16. M8x12 Ronde kopschroef x 16</p>

## MONTAGESTAPPEN

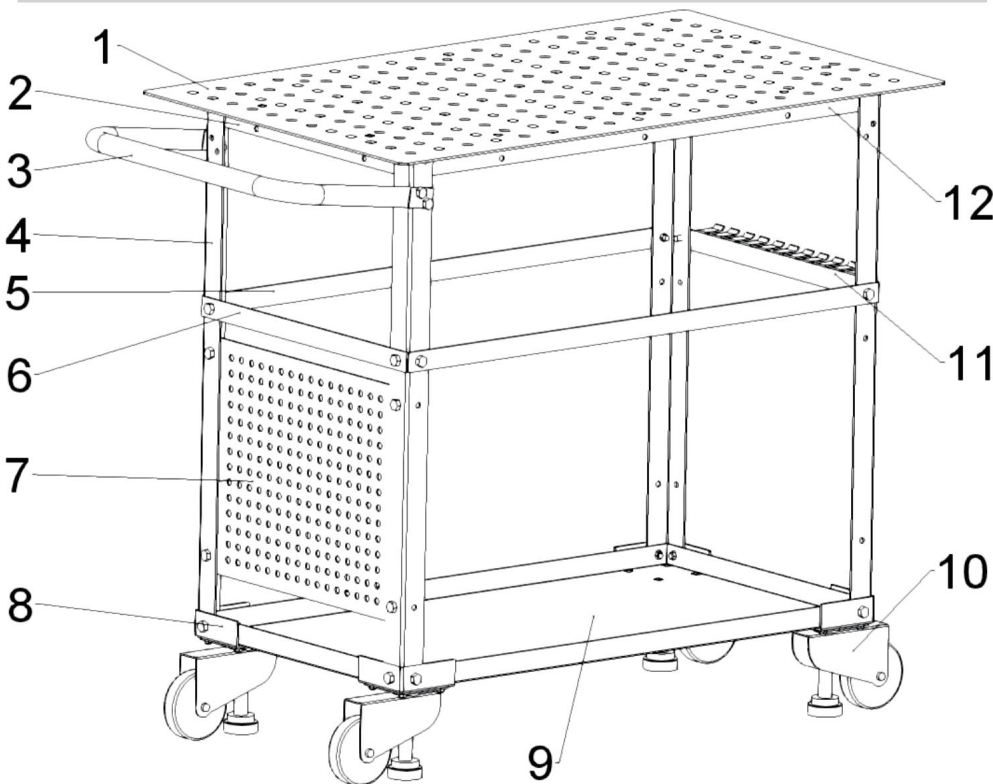

### STAP 1

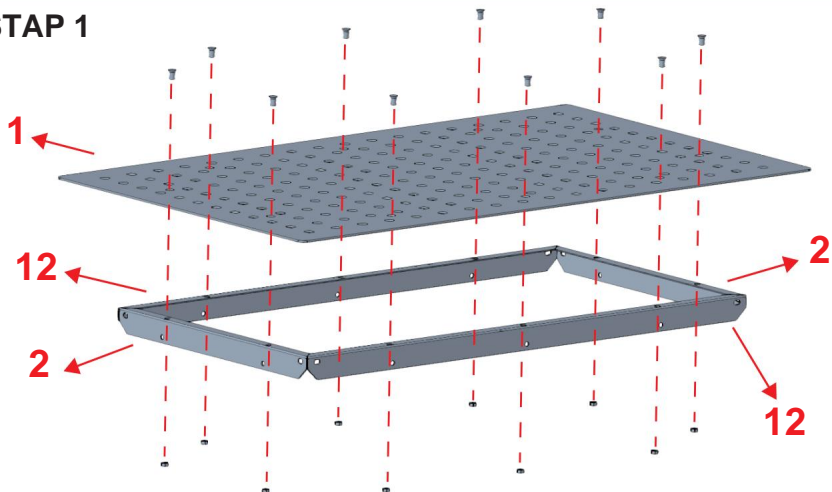

Onderdeel 1



15  x 10

13  x 10

### STAP 2

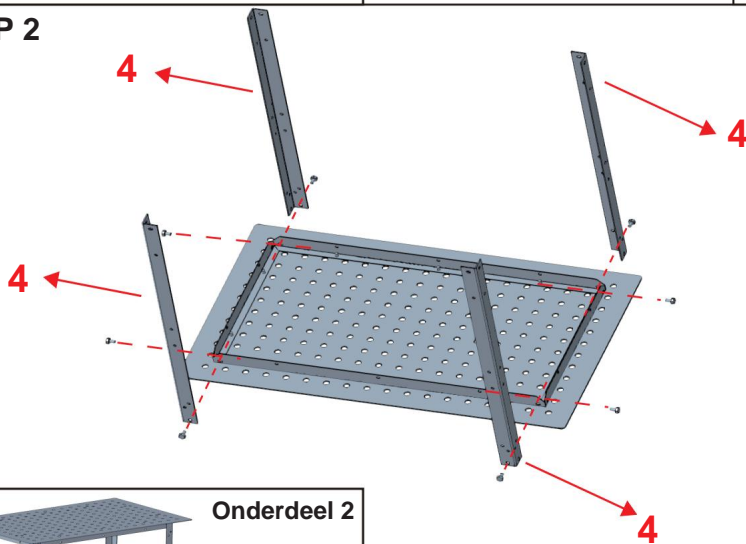

Onderdeel 2



14  x 8

13  x 8

### STAP 3

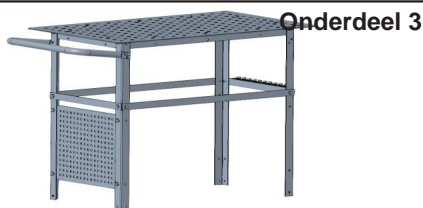
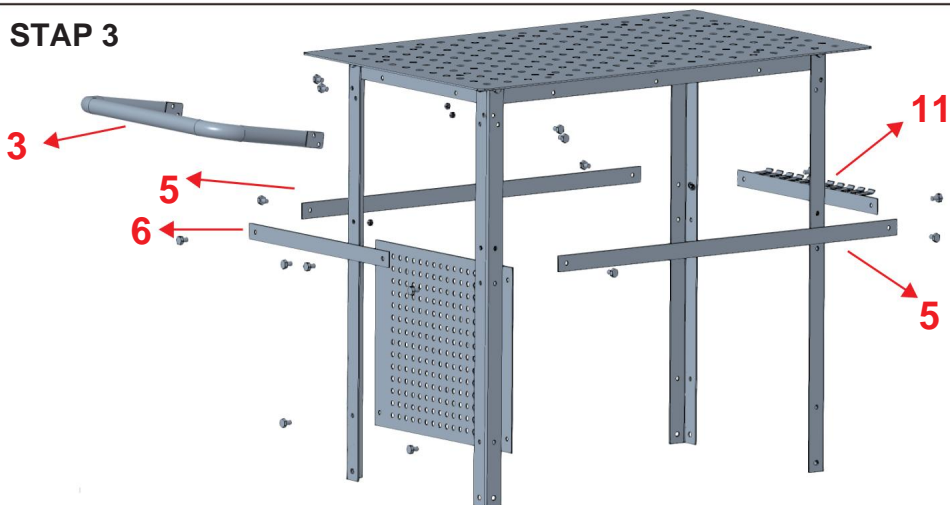

LET OP: Elke schroef is vastgezet met een moer.

14  x 16

13  x 16

### STAP 4

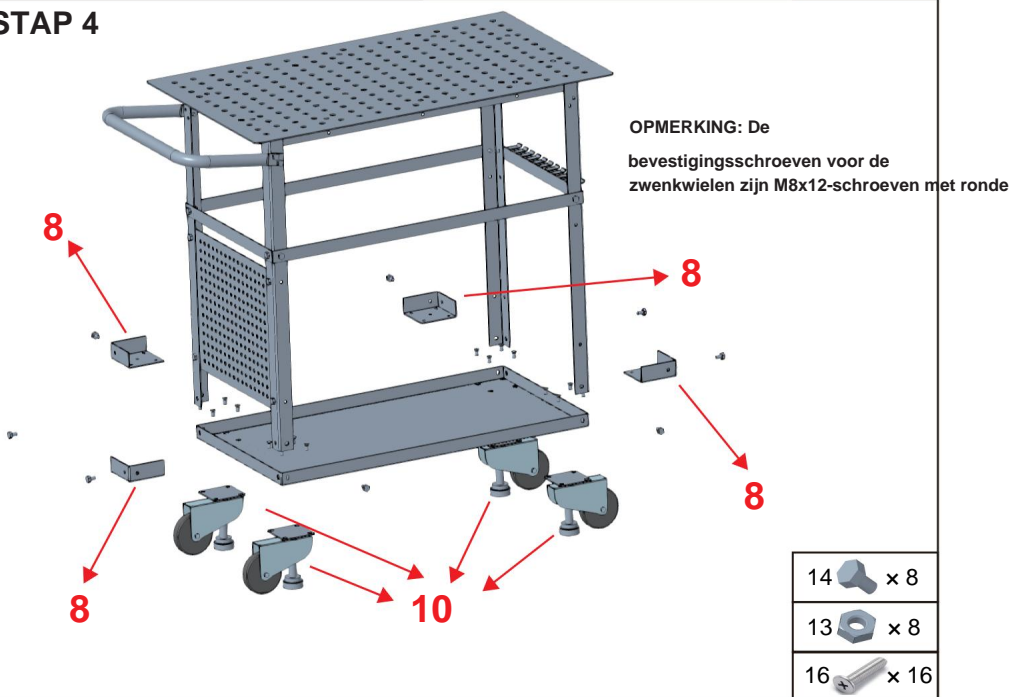

OPMERKING: De bevestigingsschroeven voor de zwenkwieken zijn M8x12-schroeven met ronde

14  x 8

13  x 8

16  x 16

**Maak uw product compleet.**



**VEVOR<sup>®</sup>**

**TOUGH TOOLS, HALF PRICE**

**Technische ondersteuning en e-garantiecertificaat**

**[www.vevor.com/support](http://www.vevor.com/support)**

**Gemaakt in China**

# VEVOR®

## TOUGH TOOLS, HALF PRICE

Teknisk support och e-garanticertifikat  
[www.vevor.com/support](http://www.vevor.com/support)

## Flyttbart svetsbord

### ANVÄNDARMANUAL

Vi fortsätter att vara engagerade i att ge dig verktyg till konkurrenskraftiga priser. "Spara halva", "halva priset" eller andra liknande uttryck som används av oss representerar bara en uppskattning av besparingar du kan dra nytta av att köpa vissa verktyg hos oss jämfört med de stora toppmärkena och doser behöver inte nödvändigtvis täcka alla kategorier av verktyg som erbjuds av oss. Du påminns vänligen om att noggrant kontrollera när du gör en beställning hos oss om du faktiskt sparar hälften i jämförelse med de främsta stora varumärkena.

**VEVOR**<sup>®</sup>  
TOUGH TOOLS, HALF PRICE

## Flyttbart svetsbord

INSTALLATIONSANVISNING

Modell: WT600

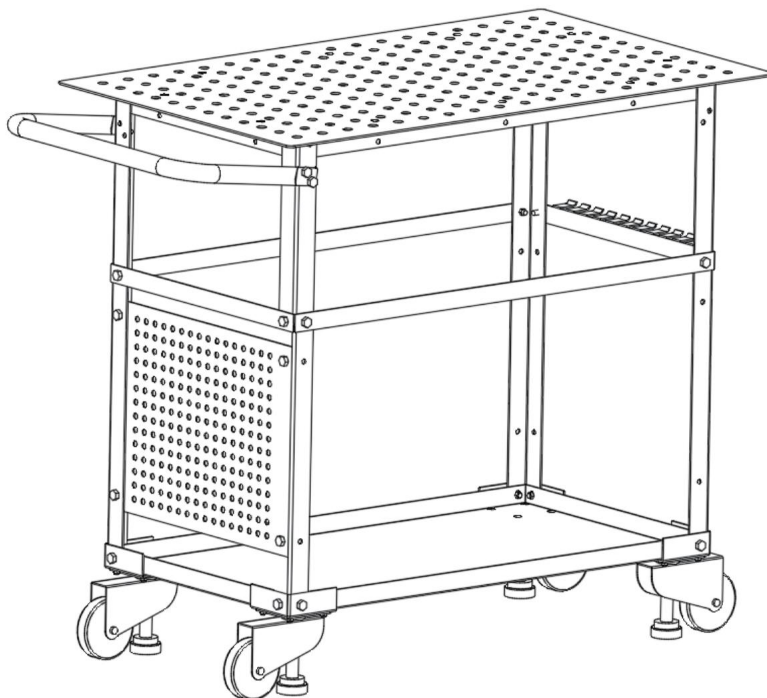

Obs: mängden delar som visas i manualen är den faktiska användningen och de oanvända delarna är reservdelar.

### BEHÖVER HJÄLP? KONTAKTA OSS!

Har du produktfrågor? Behöver du teknisk support? Kontakta oss gärna:



**CustomerService@vevor.com**

Detta är den ursprungliga instruktionen, läs alla instruktioner noggrant innan du använder den. VEVOR reserverar sig för en tydlig tolkning av vår användarmanual. Utseendet på produkten är beroende av den produkt du fått. Ursäkta oss att vi inte kommer att informera dig igen om det finns någon teknik eller mjukvaruuppdateringar på vår produkt.

## FÖRSIKTIGHETSÅTGÄRDER FÖR MONTERING

1. Montera endast enligt dessa instruktioner. Felaktig montering kan vara en fara.
2. Använd skyddsglasögon och kraftiga arbetshandskar vid montering.
3. Sätt dig inte ihop när du är trött eller påverkad av alkohol, droger eller mediciner.
4. Viktkapacitet och andra produkttegenskaper gäller för korrekt och fullständig monterade endast produkt.







## ANVÄND FÖRSIKTIGHETSÅTGÄRDER



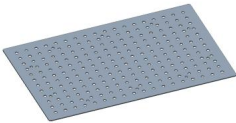
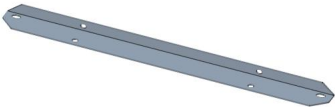



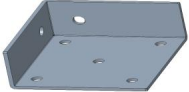

1. Denna produkt är inte en leksak. Låt inte barn leka med eller nära sig detta föremål.
2. Använd endast på avsett sätt. Sitt eller stå inte på bordet.
3. Inspektera före varje användning. Använd inte om delar är lösa eller skadade.
4. Använd endast på plan, jämn, hård yta.
5. Överskrid inte den angivna viktkapaciteten. Dra åt alla knoppar ordentligt innan du applicerar belastning.  
Var uppmärksam på dynamisk laddning! Plötsliga laströrelser kan kortvarigt skapa överbelastning som orsakar produktfel.
6. **Produktens maximala belastning är 600 lb (272 kg).**

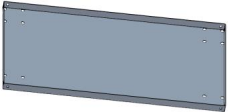
## MONTERINGSINSTRUKTIONER

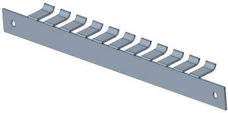
För ytterligare information om delarna som listas på följande sidor, se monteringsdiagrammet i denna handbok. Packa upp och separera alla delar på en fri arbetsyta.

## PAKETENS INNEHÅLL

 <p>1. Bordsskiva x 1</p>	 <p>2. Tallrik 1 x 2</p>
 <p>3. Handtag x 1</p>	 <p>4. Bordsben x 4</p>
 <p>5. Tallrik 2 x 2</p>	 <p>6. Tallrik 3 x 1</p>
 <p>7. Frontplåt x 1</p>	 <p>8. Hjulstöd x 4</p>

 <p>9. Verktogsplatt x 1</p>	 <p>10. Hjul Hjul x 4</p>		
 <p>11. Parplatta x 1</p>	 <p>12. Tallrik 4 x 2</p>		
 <p>13. M8 Mutter x 58</p>	 <p>14. M8x20 Skruv x 32</p>	 <p>15. M8x15 Gubbskruv x 10</p>	 <p>16. M8x12 skruv med rund huvud x 16</p>

## MONTERINGSSEG

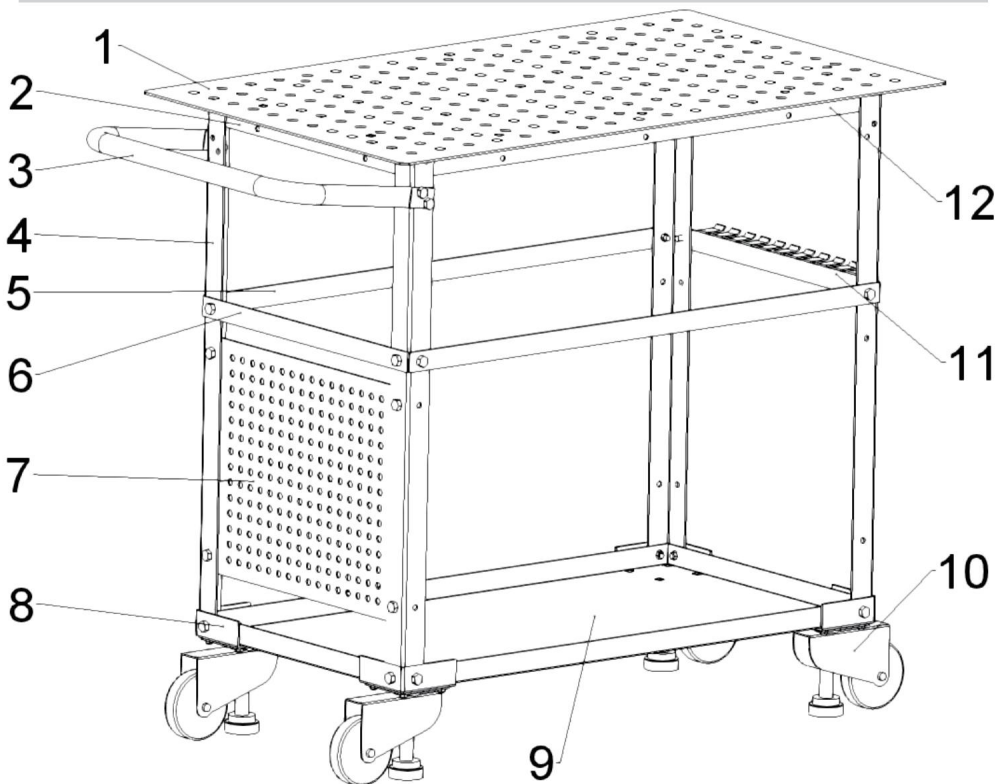

### STEG 1

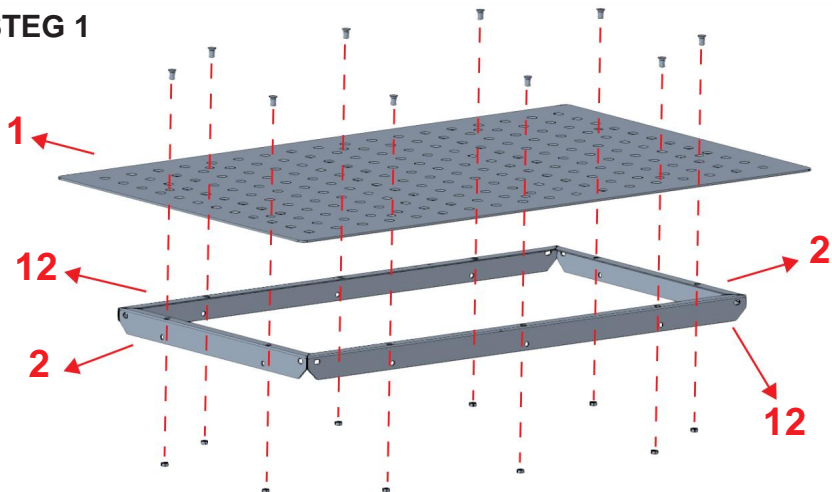

Komponent 1



15  x 10

13  x 10

### STEG 2

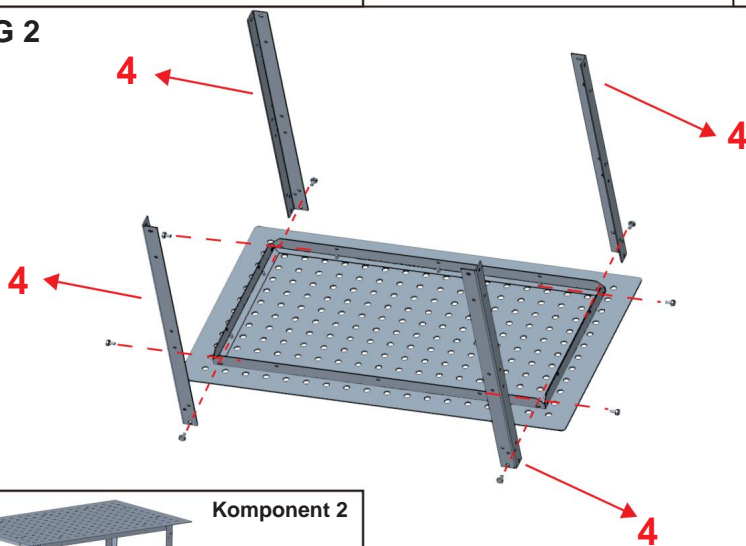

Komponent 2



14  x 8

13  x 8

### STEG 3

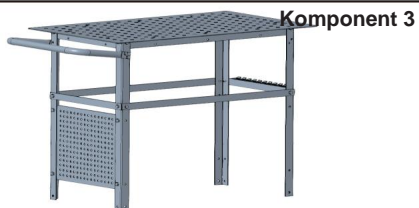
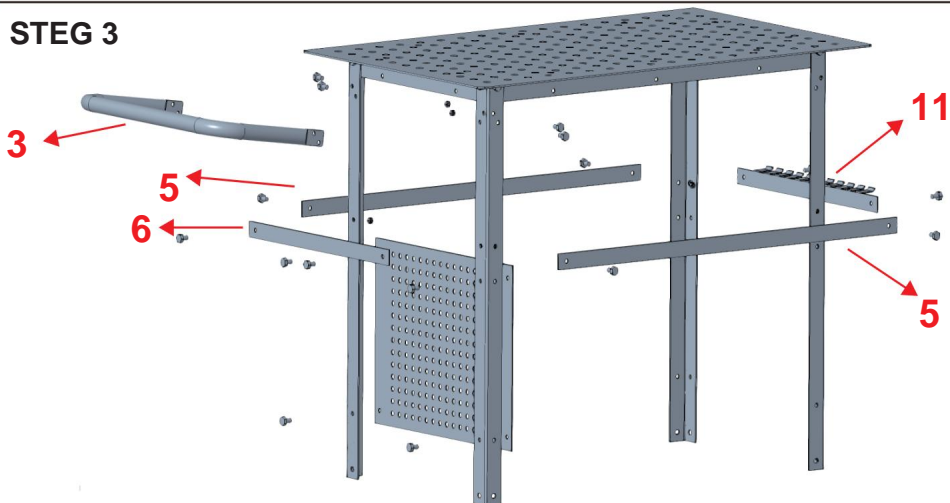

OBS: Varje skruv är låst med en mutter.

14  x 16

13  x 16

### STEG 4

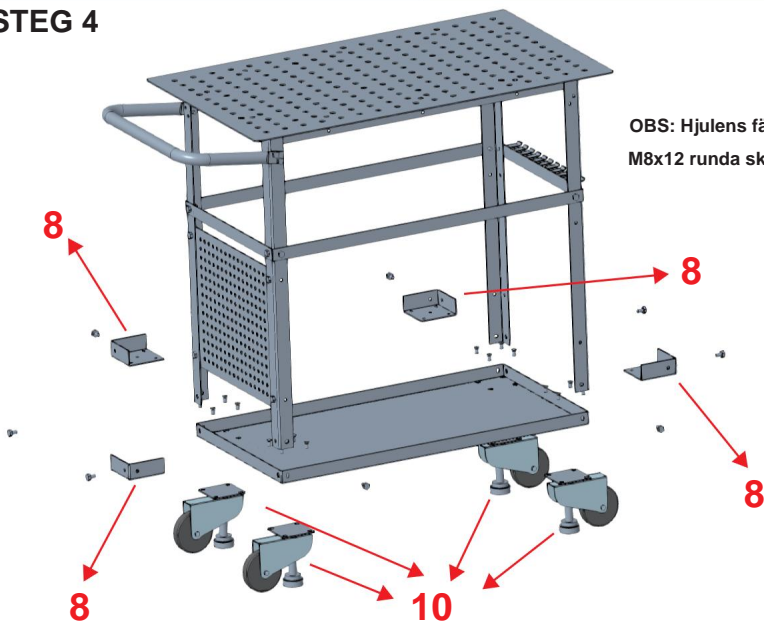

OBS: Hjulens fästskruvar är M8x12 runda skruv.

14  x 8

13  x 8

16  x 16

## Komplettera din produkt.



**VEVOR<sup>®</sup>**

**TOUGH TOOLS, HALF PRICE**

**Teknisk support och e-garanticertifikat**

**[www.vevor.com/support](http://www.vevor.com/support)**

**Tillverkad i Kina**