

KitchenAid®

PRO LINE™ SERIES

MODEL

KPCG100

BURR COFFEE MILL

Introduction Section Contents

Table of Contents	3
Proof of Purchase & Registration.....	5
Coffee Mill Safety	6
Important Safeguards.....	7
Electrical Requirements.....	8



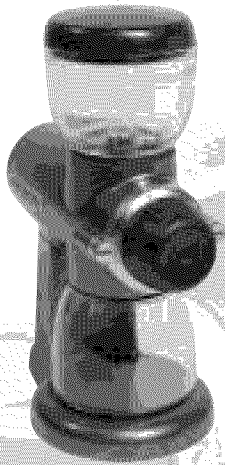

Designed to the highest standards of commercial performance and reliability, the **KitchenAid® PRO LINE™ Series Burr Coffee Mill** is your key to making the finest coffee and espresso possible.

Two precision, flat cutting burrs will grind your coffee to superb consistency, while the low-noise DC motor and gear reduction system work to minimize the frictional heating of the grinds, maximizing your coffee's flavor and aroma. The all-metal housing and glass hoppers are not only durable, stylish, and easily cleaned, they help reduce the static "cling" of coffee grinds common with plastic components.

The PRO LINE™ Series Burr Coffee Mill has been designed for years of heavy use: the durable stainless steel cutting burrs can be easily adjusted to compensate for wear or replaced if damaged. Like the famous KitchenAid® Stand Mixer, the PRO LINE™ Series Burr Coffee Mill features performance that can be enjoyed from generation to generation.

The KitchenAid® PRO LINE™ Series: commercial quality for the discriminating home chef. From the company distinguished by its legendary craftsmanship.

TABLE OF CONTENTS

INTRODUCTION

Introduction.....	2
Proof of Purchase & Product Registration	5
Coffee Maker Safety	6
Important Safeguards	7
Electrical Requirements	8

FEATURES AND OPERATION

Coffee Mill Features.....	10
Using the Coffee Mill	
Before First Use.....	13
Operating the Mill	13
Grind Setting Table	16
Adjusting the Cutting Burrs	16
Coffee Mill Tips	19
How the Grind Affects Flavor	21

CARE AND CLEANING

Cleaning the Motor Housing & Hoppers	24
Cutting Burrs	
Cleaning	25
Adjusting for Wear	28
Replacing	29
Troubleshooting.....	30

TABLE OF CONTENTS

WARRANTY AND SERVICE INFORMATION

Warranty for the 50 United States & District of Columbia.....	32
Warranty for Puerto Rico	33
Arranging for Hassle-Free Replacement.....	34
Ordering Accessories and Replacement Parts	34
Arranging for Service After the Warranty Expires	35
Arranging for Service Outside the 50 United States & Puerto Rico.....	35

PROOF OF PURCHASE & PRODUCT REGISTRATION

Always keep a copy of the sales receipt showing the date of purchase of your Coffee Mill. Proof of purchase will assure you of in-warranty service.

Before you use your Coffee Mill, please fill out and mail your product registration card packed with the unit. This card will enable us to contact you in the unlikely event of a product safety notification and assist us in complying with the provisions of the Consumer Product Safety Act. This card does not verify your warranty.

Please complete the following for your personal records:

Model Number: KPCG100

Serial Number _____

Date Purchased _____

Store Name _____

COFFEE MILL SAFETY

Your safety and the safety of others are very important.

We have provided many important safety messages in this manual and on your appliance. Always read and obey all safety messages.



This is the safety alert symbol.

This symbol alerts you to potential hazards that can kill or hurt you and others.

All safety messages will follow the safety alert symbol and either the word "DANGER" or "WARNING." These words mean:

 **DANGER**

You can be killed or seriously injured if you don't immediately follow instructions.

 **WARNING**

You can be killed or seriously injured if you don't follow instructions.

All safety messages will tell you what the potential hazard is, tell you how to reduce the chance of injury, and tell you what can happen if the instructions are not followed.

IMPORTANT SAFEGUARDS

When using electrical appliances, basic safety precautions should always be followed, including the following:

1. Read all instructions.
2. To protect against the risk of electric shock, do not put the Coffee Mill in water or other liquids.
3. Close supervision is necessary when any appliance is used by or near children.
4. Unplug the Coffee Mill from the outlet when not in use, before putting on or taking off parts, and before cleaning.
5. Avoid contacting moving parts.
6. Do not operate any appliance with a damaged cord or plug, or after the appliance malfunctions or is dropped or damaged in any manner. Return the appliance to the nearest authorized service facility for examination, repair, or electrical or mechanical adjustment.
7. The use of attachments not recommended or sold by KitchenAid may cause fire, electric shock, or injury.
8. Do not use outdoors.
9. Do not let cord hang over edge of table or counter, or touch hot surfaces.
10. Check the bean hopper for the presence of foreign objects before using.
11. This product has been UL Listed for household and commercial use.

SAVE THESE INSTRUCTIONS

ELECTRICAL REQUIREMENTS

Volts: 120 V.A.C. only.

Hertz: 60 Hz

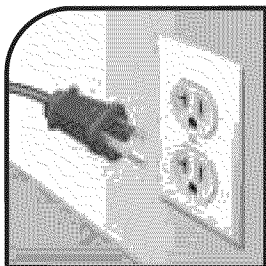

NOTE: This Coffee Mill has a 3 prong grounded plug. To reduce the risk of electrical shock, this plug will fit in an

outlet only one way. If the plug does not fit in the outlet, contact a qualified electrician. Do not modify the plug in any way.

A short power-supply cord is provided to reduce the risk resulting from becoming entangled in or tripping over a longer cord.

Extension cords are available and may be used if care is exercised in their use.

If a longer extension cord is used:

- The marked electrical rating of the extension cord should be at least as great as the electrical rating of the appliance.
- The extension cord should be a grounding-type 3 wire cord.
- The cord should be arranged so it will not drape over the countertop or tabletop where it can be pulled on by children or tripped over.

WARNING



Electrical Shock Hazard

Plug into a grounded 3 prong outlet.

Do not remove ground prong.

Do not use an adapter.

Failure to follow these instructions can result in death, fire, or electrical shock.



KitchenAid[®]
PRO LINE™ SERIES

FEATURES AND OPERATION

Features and Operation Section Contents

Coffee Mill Features	10
Using the Coffee Mill	
Before First Use	13
Operating the Coffee Mill	13
Grind Setting Table	16
Adjusting the Cutting Burrs	16
Coffee Mill Tips	19
How the Grind Affects Flavor	21



MODEL KPCG100

BURR COFFEE MILL FEATURES

Model KPCG100
Burr Coffee Mill



Motor Housing

Die-cast metal housing is stable, durable, and easy to clean.

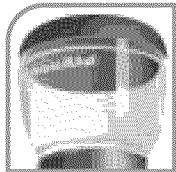

Bean Hopper

7 oz. capacity bean hopper unscrews from the motor housing for simple cleaning. Press-fit hopper lid makes for quick and easy filling. Hopper and lid are dishwasher-safe (top rack only).

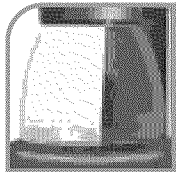

Coffee Bin

Coffee bin is glass to minimize the static "cling" of coffee grinds. Bin is dishwasher-safe (top rack only).

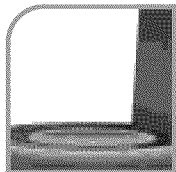

Bin Platform

Platform pad seats the coffee bin under the grinding spout.

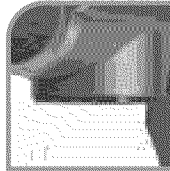

Bin Seal Plate

Plate helps position the coffee bin under the grinding spout and prevents coffee grinds from escaping.

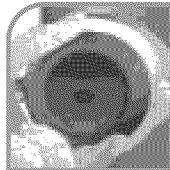

Grind Control Dial

Large, easy-to-use dial selects one of 15 grind levels in half-step increments from 1 to 8.

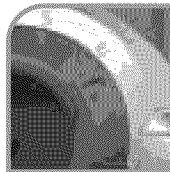

Grind Level Ring

Metal ring displays grind levels 1 (coarse) through 8 (fine).

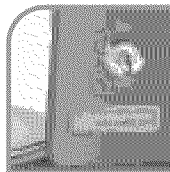

On/Off Switch

Switch "On" to grind, "Off" to stop.

Continued...

BURR COFFEE MILL FEATURES

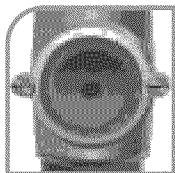

Faceplate Assembly & Screws

Assembly includes the grind control dial and grind level ring. Two

faceplate screws attach the faceplate assembly to the motor housing. Loosen the screws and remove the faceplate assembly to access the burrs.

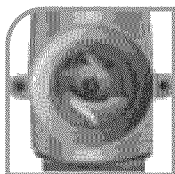

Precision Stainless Steel Cutting Burrs

Large 2¼-inch diameter flat cutting burrs provide long life

and superb grind consistency. Burrs can be adjusted to compensate for wear, or calibrated to meet stringent Specialty Coffee Association of America guidelines for espresso and French Press grinds.

Low-RPM Operation

A special DC motor and gear reduction system slows the rotation of the cutting burrs, minimizing the frictional heating of the grinds and preserving coffee flavor and aroma. The low rpm operation also reduces the static charge – and “cling” – of coffee grinds.

Power Cord with Tie

Round cord has no grind-trapping seams; the tie can be used to bundle any excess.

One-Piece Metal Base with No-Slip Rubber Feet

Metal base provides a stable platform for the grinder. Rubber feet dampen noise and vibration, and help protect the countertop.

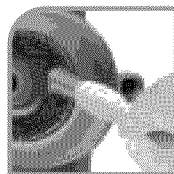

Burr Cleaning Brush

Dense bristles sweep grinds from the cutting burrs quickly and easily.

USING THE PRO LINE™ SERIES

BURR COFFEE MILL

Before First Use

Before using the coffee mill, wipe the motor housing and cord with a clean damp cloth. Wash the bean hopper, hopper lid, and coffee bin in hot soapy water, then rinse and dry. The bean hopper, hopper lid, and coffee bin can also be washed in the top rack of a dishwasher.

Operating the Coffee Mill

1. Make certain the coffee mill is unplugged. Attach the bean hopper to the top of the motor housing by turning the hopper clockwise until snug.

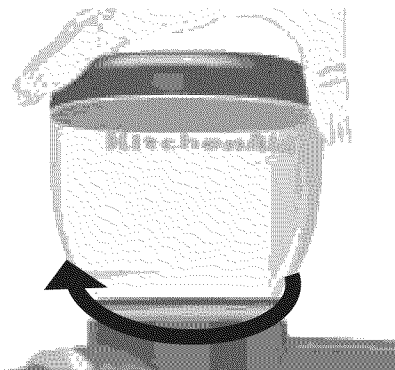

2. Slide the coffee bin onto the bin platform; the bin seal plate on the motor housing will compress slightly to accommodate the bin. Make certain the bin is centered in the middle of the bin platform.

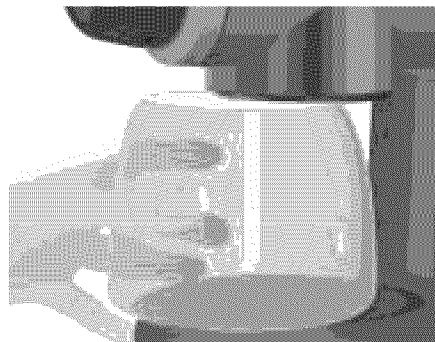

3. Fill the bean hopper to the level desired. At maximum, the hopper holds 7 oz. of beans.

NOTE: This product is intended to grind whole coffee beans only.

Continued...

USING THE PRO LINE™ SERIES

BURR COFFEE MILL

⚠ WARNING



Electrical Shock Hazard

Plug into a grounded 3 prong outlet.

Do not remove ground prong.

Do not use an adapter.

Failure to follow these instructions can result in death, fire, or electrical shock.

4. Place the hopper lid onto the hopper.
5. Plug into a grounded 3 prong outlet. The tie provided on the power cord can be used to bundle any excess cord.

6. Select the grind by turning the grind control dial to the desired setting on the grind level ring. See the grind setting table on the next page to match the grind level to your brewing process. With use, you'll be able to refine the settings to match your own tastes.

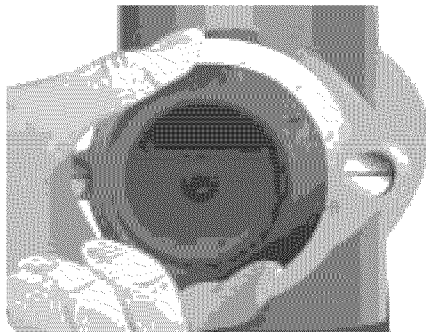

NOTE: Because partially ground coffee beans may remain between the burrs after the grinder is turned off, selecting a finer grind may be easier when the coffee mill is running.

7. To grind coffee, flip the On/Off Switch to the "On" position.

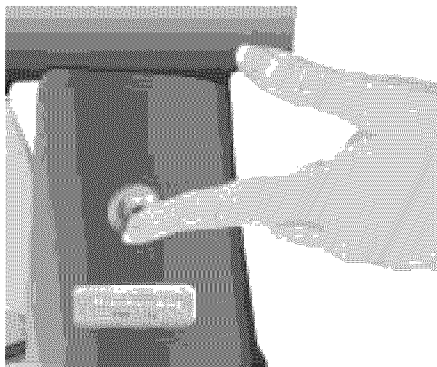

8. When the desired amount of coffee has been ground, flip the On/Off Switch to the "Off" position, remove the coffee container, and scoop out the ground coffee.

ADJUSTING THE CUTTING BURRS

Grind Setting Table

Setting	Grind	For	Average Grind Size <small>produced by the coffee mill before adjustment</small>
8	Fine	Espresso	325 microns
5	Medium	Automatic Drip	750 microns
1	Coarse	French Press	1250 microns

Adjusting the Cutting Burrs

From the factory, the PRO LINE™ Series Burr Coffee Mill will provide grinds suitable for almost all types of brewing. If you're an espresso or French Press aficionado, however, you may wish to adjust the cutting burrs to provide optimum performance for your style of brewing. With adjustment, the PRO LINE™ Series Burr Coffee Mill will easily meet stringent Specialty Coffee Association of America grind-size specifications for espresso (250 micron grind size) or French Press brewing (1500 micron grind size).

Adjusting for Maximum Grind Fineness

Adjusting the mill to provide maximum fineness will slightly decrease the grind sizes throughout the grinding range. (To adjust the mill to provide coarser grinds, see page 18.)

1. Empty the bean hopper, then run the mill a few seconds to clear any remaining beans from the machine.
2. Turn the grind control dial to level "8".

- Using a ½-inch allen wrench or hex-head screwdriver, remove the screw located in the front of the grind control dial by turning it counter-clockwise. Hold the grind control dial so that it does not rotate as the screw is removed. Once the screw is free, remove the grind control dial.

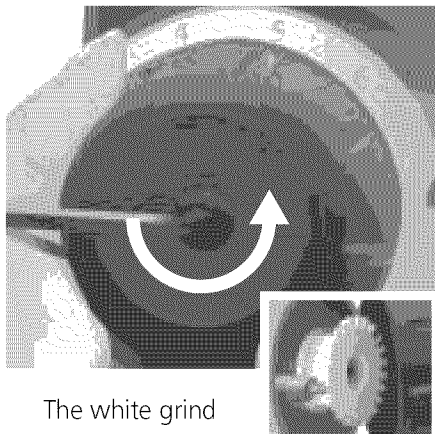

The white grind control gear should be visible once the grind control dial is removed.

- Turn on the mill by flipping the On/Off Switch to the "On" position.

- Rotate the grind control gear clockwise 1 "click" or detent at a time until you hear the burrs touching one another – when they touch, the burrs will make a distinct "rubbing" or grating sound.

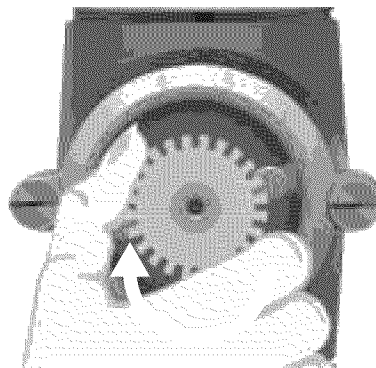

- When the burrs are touching, turn the grind control gear counter-clockwise 1 "click" or detent. The grating or "rubbing" sound will stop. Turn off the mill by flipping the On/Off Switch to the "Off" position. The mill is now calibrated to provide maximum fineness.

ADJUSTING THE CUTTING BURRS

7. Re-attach the grind control dial, making certain the dial indicator points to grind level "8".

NOTE: If the coffee mill produces a grating or "rubbing" sound during use, the burrs have been improperly adjusted. Damage to the burrs will result. Readjust the burrs immediately.

Adjusting to Provide Coarser Grinds

When the mill is adjusted to provide coarser grinds, grind sizes will increase throughout the grinding range and the finest level may become too coarse for espresso. (To re-calibrate the grinder for maximum fineness, see page 16.)

1. Turn the grind control dial to level "1".
2. Using a $\frac{5}{32}$ -inch allen wrench or hex-head screwdriver, remove the screw located in the front of the grind control dial by turning it counter-clockwise. Once the

screw is free, remove the grind control dial. The white grind control gear should be visible once the dial is removed.

3. Rotate the grind control gear counter-clockwise 1 "click" or detent at a time until the "clicking" sound diminishes and the gear offers little resistance to being turned.

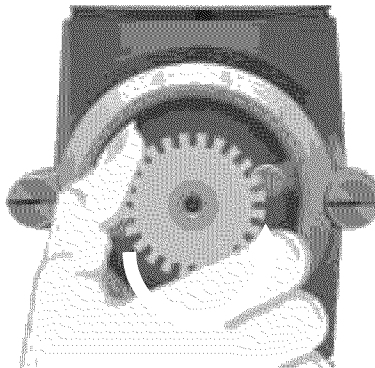

4. Re-attach the grind control dial, making certain the dial indicator points to level "1".

BURR COFFEE MILL TIPS

1



Select the correct grind for the brew process you are using. 15 grind levels are available in half-step increments from 1 to 8. Level 8 produces a very fine grind perfect for espresso, 4½ to 6 are medium grinds appropriate for automatic drip coffee makers, and 1 is a coarse grind suited to French Press brewing. Experiment – your tastes may be better served by using a slightly finer or coarser grind.

2



For standard drip-process coffee, a good starting point is to use 1 ounce of coffee for every 4 cups of brew water as measured with the carafe (a carafe “cup” is about 4¼ ounces). Finer grinds usually require less coffee, but using too fine a grind will result in bitter flavor – see “How the Grind Affects Flavor” on page 21.

If you prefer substantially weaker-than-average coffee, it’s best to brew using a normal amount of ground coffee and then dilute the result with hot water. Doing this will maximize flavor and minimize bitterness.

BURR COFFEE MILL TIPS

3

Ground coffee loses flavor and aroma very quickly. For the best results, grind only as much as you intend to immediately use.

4

To retain freshness, coffee beans should be stored in an airtight container and kept in a cool, dark place. It is not recommended that you store beans in the grinder's bean hopper for a prolonged period.

5

Clean the coffee bin and cutting burrs frequently.

6

Grinding flavored coffee beans will impart an off-taste to any other coffee that is ground in the mill. If you enjoy flavored coffee, it's best to add flavored syrups or creamers to your coffee after brewing or dedicate another mill for grinding flavored beans only.

NOTE: The burrs will require more frequent cleaning when grinding flavored coffee beans. The coffee mill is intended for grinding whole coffee beans only. Do not grind other food items.

HOW THE GRIND AFFECTS FLAVOR

The flavor of coffee depends on a variety of factors, including the quality, freshness, and roast of the beans, the purity of the brew water, the cleanliness of the brewing equipment, and the brewing temperature. The fineness and consistency of the grind is also critical.

oils and essences, resulting in a very thin and weak flavor. If the correct grind is used, adding more coffee simply makes a brew stronger without making it excessively bitter.

The consistency of the grind is also an important factor in the flavor of coffee – and absolutely critical



Coffee that is ground too fine for a particular brewing process – using a fine espresso grind in a drip coffee maker, for example – will result in the brew water over-extracting the oils and aromatic compounds in the coffee, yielding a brew that is extremely pungent and bitter. Conversely, coffee that is too coarsely ground for a particular process will result in the under-extraction of the

when making great espresso. If the grounds are uniform, equal amounts of soluble compounds will be extracted from each. If the grounds vary in size, some will be over-extracted and some will be under-extracted, leading to extremely poor quality. It's not surprising that a precision grind is mandatory for good espresso, which is brewed with near-boiling water under 130-lbs. of pressure.

Continued...

Coffee grind quality is directly related to the type of grinder used. High speed grinders with small burr sets are usually not able to produce the fineness or consistency required for the best espresso. They also excessively heat the beans while grinding, resulting in lost flavor and aroma.

The PRO LINE™ Series Burr Coffee Mill uses a pair of large, commercial-style cutting burrs to grind coffee with precision. Frictional heating is minimized with a gear reduction system that slows burr rotation, and uniformity is enhanced with a helical-gear that transports beans to the burrs at a controlled rate. The result is a superb grind that makes your coffee and espresso the best it can be.

KitchenAid®

PRO LINE™ SERIES

CARE AND CLEANING

Care and Cleaning Section Contents

Cleaning the Housing & Hoppers.....	24
Cutting burrs	
Cleaning	25
Adjusting for Wear	28
Replacing	29
Troubleshooting.....	30

CARE AND CLEANING

Cleaning the Motor Housing and Hoppers

- Make sure the coffee mill is switched off and unplugged before cleaning.
- Do not immerse the motor housing in water.
- Never immerse the cutting burrs, burr-shaft assembly, or face-plate assembly in water. Keep them dry at all times.
- Do not use abrasive cleansers or scouring pads.

Wipe the motor housing and cord with a clean damp cloth. Dry with a soft cloth.

Wash the coffee bin, bean hopper, and hopper lid in hot soapy water, then rinse and dry.

The bean hopper, hopper lid, and coffee bin can also be washed in the top rack of a dishwasher.

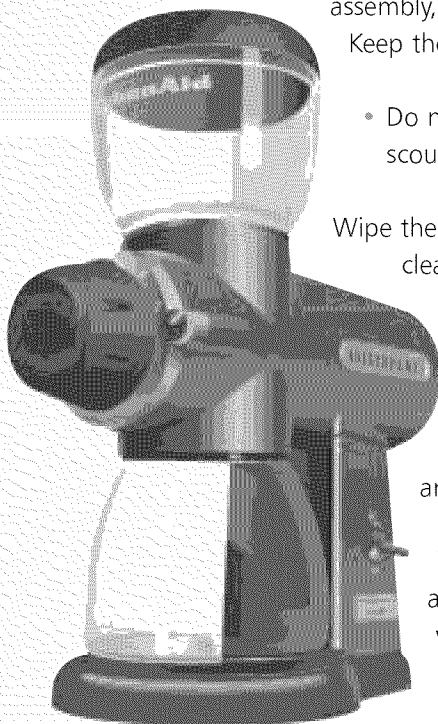

Cleaning the Cutting Burrs

If the mill is used frequently, the cutting burrs need to be cleaned every few weeks for best performance. Cleaning enables the burrs to achieve the finest, most consistent grinds possible – which is especially important when grinding coffee for espresso.

Foreign objects – like pebbles or twigs – sometimes find their way into whole bean coffee. These objects may cause the mill to jam. If this happens, follow the burr-cleaning procedure to remove the foreign material.

1. Make sure the mill is switched off and unplugged. Remove the coffee bin and bean hopper from the mill.

2. Using a flat-head screwdriver, turn the two faceplate screws counter-clockwise until the faceplate assembly is free. (The faceplate screws have retaining clips that prevent them from being removed from the faceplate assembly.)

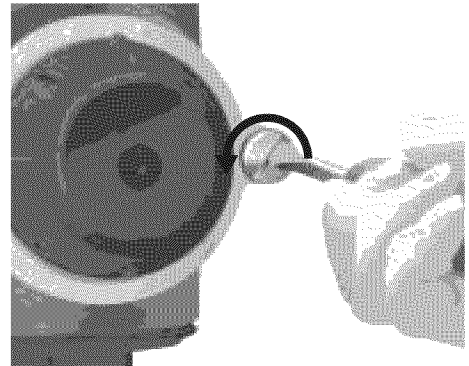

Continued...

CARE AND CLEANING

- Carefully slide the faceplate assembly away from the motor housing. A separate burr-shaft assembly on the inside of the motor housing will usually slide out with the face plate assembly. Place a hand under the burr-shaft assembly to prevent it from falling as the faceplate assembly is removed. If the burr-shaft assembly does not slide out with the face-plate assembly, grasp the center shaft of the burr-shaft assembly and remove it from the housing.

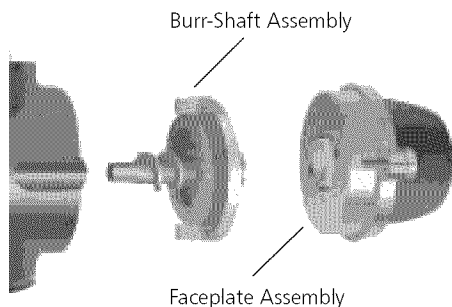

- Using the burr-cleaning brush, clean the burr mounted on the burr-shaft assembly and the burr mounted within the motor housing.

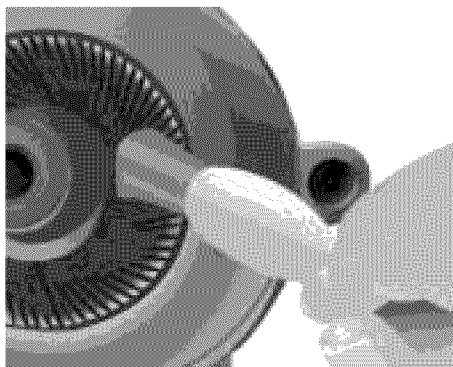
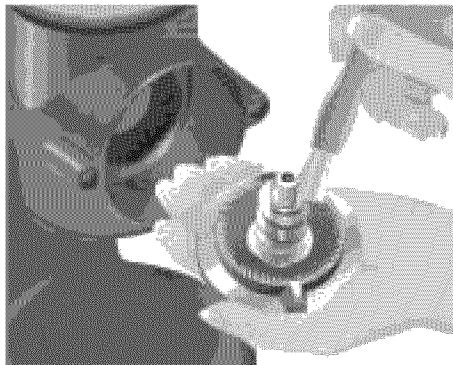

NOTE: Never wash the burrs or burr-shaft assembly in water. Keep them dry at all times.

5. After cleaning, tilt the grinder backward so the front of the motor housing faces upward.

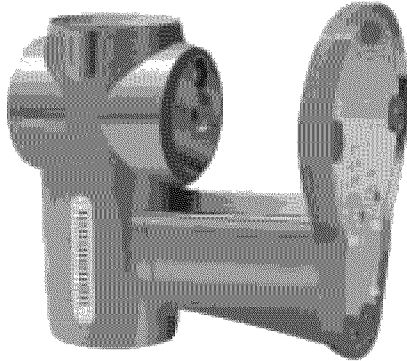

6. With the corkscrew-shaped auger shaft facing into the motor housing, insert the burr-shaft assembly into the grinder. Keep the burr-shaft assembly level, so the tip of the auger shaft will line up with the small socket in the motor housing.

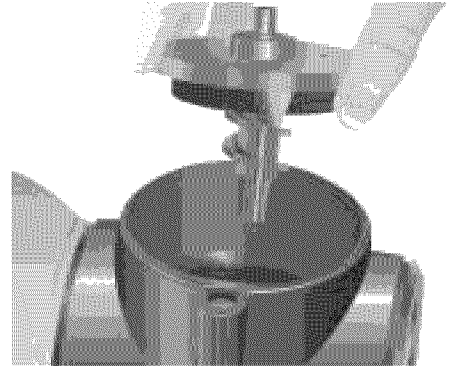

7. Once the burr-shaft assembly is in the motor housing, rotate the assembly until it falls into place. When correctly positioned, the burr-shaft assembly cannot be rotated.

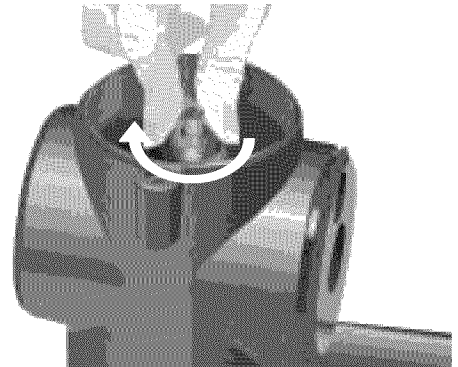

Continued...

CARE AND CLEANING

- Place the faceplate assembly onto the motor housing. Make sure the numbers on grind level ring are positioned across the top of the assembly. Using your fingers, tighten the faceplate screws by turning them clockwise. Alternate tightening the screws, keeping them even – do not completely tighten one screw before tightening the other.

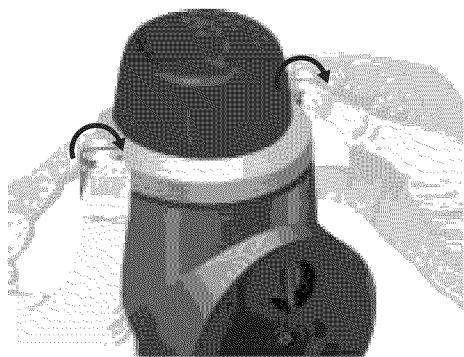

- After the faceplate screws have been finger-tightened, use a flat-head screwdriver to tighten them until snug.
- Place the grinder upright. It is now ready for use.

Adjusting The Cutting Burrs For Wear

The cutting burrs are made of high-quality stainless steel for exceptional longevity. After prolonged use, however, the burrs might require adjustment to compensate for wear. If your grinds – especially espresso – are not as fine as they used to be, an adjustment probably needs to be made.

Please see “Adjusting the Cutting Burrs” on page 16 for information on adjusting the burrs to provide maximum grind fineness.

Replacing the Cutting Burrs

If the cutting burrs are damaged, or have reached the end of their life (usually after grinding 600–800 lbs. of coffee), they can be replaced easily. Contact KitchenAid at 1-800-541-6390 to order a set of replacement burrs.

To replace the burrs:

1. Remove the faceplate and burr-shaft assemblies. For instructions, see “Cleaning the Cutting Burrs” steps 1, 2, and 3 on pages 25 and 26.
2. With a Phillips screwdriver, remove the burr from the burr-shaft assembly by turning the two burr-mounting screws counter-clockwise until free.

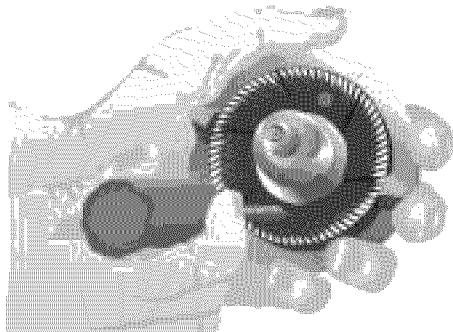

3. Remove the burr from the motor housing by turning the two burr-mounting screws counter-clockwise until free.

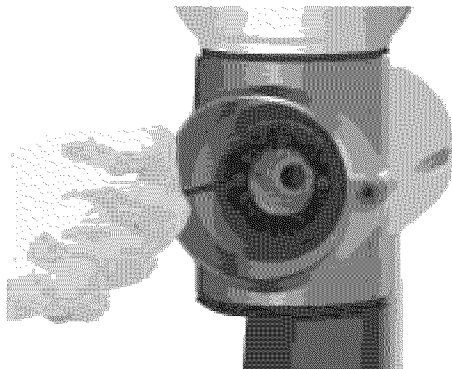

4. Attach the replacement burrs to the burr-shaft assembly and motor housing using the burr-mounting screws. Make certain the cutting surfaces of the burrs face outward, and the burr-mounting screws are tight.
5. Insert the burr-shaft assembly into the motor housing and attach the faceplate assembly. For instructions, see “Cleaning the Cutting Burrs” steps 5 – 10 on pages 27 and 28.

TROUBLESHOOTING

- **If the mill does not run when switched on:**

Check to see if the mill is plugged into a grounded 3 prong outlet. If it is, unplug the mill, then plug it back in again. If the grinder still does not work, check the fuse or circuit breaker on the electrical circuit the mill is connected to and make sure the circuit is closed. If the mill does not run after taking these steps, a foreign object may be jamming the cutting burrs. See “Cleaning the Cutting Burrs” on page 25 for more information.

- **If the mill runs when switched on, but coffee does not grind:**

The cutting burrs require cleaning or are worn. See “Cleaning the Cutting Burrs” on page 25 or “Replacing the Cutting Burrs” on page 29 for more information.

- **If the mill is operating normally, but stops abruptly:**

Immediately turn off the grinder. A foreign object, such as a pebble or twig, may have jammed the cutting burrs. See “Cleaning the Cutting Burrs” on page 25 for more information.

- **If the grind is too coarse, or the mill isn’t producing an acceptable range of grinds:**

See “Adjusting the Cutting Burrs” on page 16 or “Replacing the Cutting Burrs” on page 29 for more information.

If the problem cannot be fixed with the steps above, see the KitchenAid Warranty and Service section on the following page.*

*Do not return the coffee mill to the retailer. Retailers do not provide service.

KitchenAid®

PRO LINE™ SERIES

WARRANTY AND SERVICE INFORMATION

Warranty Information Section Contents

Warranty for the U.S.	32
Warranty for Puerto Rico	33
Arranging for Hassle-Free Replacement	34
Ordering Accessories and Replacement Parts	34
Arranging for Service After the Warranty Expires	35
Arranging for Service Outside the U.S. & Puerto Rico	35

COFFEE MILL **WARRANTY**

FOR THE **50 UNITED STATES**

AND DISTRICT OF COLUMBIA

This warranty extends to the purchaser and any succeeding owner for PRO LINE™ Series Burr Coffee Mills operated in the 50 United States and District of Columbia.

Length of Warranty:	KitchenAid Will Pay For Your Choice of:	KitchenAid Will Not Pay For:
<p>Two Year Full Warranty for Household Use, from date of purchase.</p>	<div data-bbox="364 413 517 567" data-label="Image"> </div> <p>Hassle-Free Replacement of your Coffee Mill. See "Arranging for Hassle-Free Replacement" for details, or call the KitchenAid Customer Satisfaction Center toll-free at 1-800-541-6390. OR The replacement parts and repair labor costs to correct defects in materials and workmanship. Service must be provided by an Authorized KitchenAid Service Center. See the KitchenAid® PRO LINE™ Series Burr Coffee Mill Warranty for Puerto Rico for details on how to arrange for service.</p>	<ul style="list-style-type: none"> A. Repairs when the Coffee Mill is used in other than normal single family home use. B. Damage resulting from accident, alteration, misuse or abuse. C. Any shipping or handling costs to deliver your Coffee Mill to an Authorized Service Center. D. Replacement parts or repair labor costs for Coffee Mills operated outside the 50 United States and District of Columbia.

KITCHENAID DOES NOT ASSUME ANY RESPONSIBILITY FOR INCIDENTAL OR CONSEQUENTIAL DAMAGES. Some states do not allow the exclusion or limitation of incidental or consequential damages, so this exclusion may not apply to you. This warranty gives you specific legal rights and you may also have other rights which vary from state to state.

COFFEE MILL
WARRANTY
FOR **PUERTO RICO**

A limited two year warranty extends to the purchaser and any succeeding owner for PRO LINE™ Series Burr Coffee Mills operated in Puerto Rico. During the warranty period, all service must be handled by an Authorized KitchenAid Service Center.

Please bring the Coffee Mill, or ship it prepaid and insured, to the nearest Authorized Service Center. Call toll-free **1-800-541-6390** Monday through Friday, 8 a.m. to 8 p.m. (Eastern Time), or Saturday, 10 a.m. to 5 p.m. to learn the location of a Service Center near you. Your repaired Coffee Mill will be returned to you prepaid and insured.

ARRANGING FOR **HASSLE-FREE** REPLACEMENT

IF YOU RESIDE IN THE 50 UNITED STATES and your KitchenAid® PRO LINE™ Series Burr Coffee Mill should fail within two years of ownership, simply call our toll-free Customer Satisfaction Center at **1-800-541-6390** Monday through Friday, 8 a.m. to 8 p.m. (Eastern Time), or Saturday, 10 a.m. to 5 p.m. Give the consultant your complete shipping address. (No P.O. Box Numbers, please.)

KitchenAid will arrange to deliver an identical or comparable replacement to your door free of charge and arrange to have your “failed” Coffee Mill returned to us. Your replacement unit will also be covered by our two year full warranty.

When you receive your replacement PRO LINE™ Series Burr Coffee Mill, use the carton and packing materials to pack-up your “failed” Coffee Mill. In the carton, include your name and address on a sheet of paper along with a copy of the proof of purchase (register receipt, credit card charge slip, etc.).

ORDERING **ACCESSORIES** AND **REPLACEMENT** PARTS

To order accessories or replacement parts for your Coffee Mill, call toll-free **1-800-541-6390** Monday through Friday, 8 a.m. to 8 p.m. (Eastern Time), or Saturday, 10 a.m. to 5 p.m., or write to: Customer Satisfaction Center, KitchenAid Portable Appliances, P.O. Box 218, St. Joseph, MI 49085-0218.

ARRANGING FOR **SERVICE** AFTER THE **WARRANTY** EXPIRES

For service information, call toll-free **1-800-541-6390** Monday through Friday, 8 a.m. to 8 p.m. (Eastern Time), or Saturday, 10 a.m. to 5 p.m., or write to: Customer Satisfaction Center, KitchenAid Portable Appliances, P.O. Box 218, St. Joseph, MI 49085-0218.

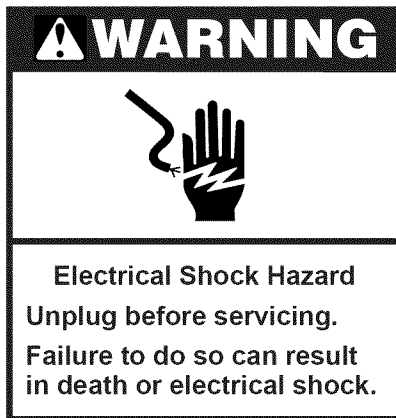

ARRANGING FOR **SERVICE** OUTSIDE THE **50 UNITED STATES** AND PUERTO RICO

Consult your local KitchenAid dealer or the store where you purchased your PRO LINE™ Series Burr Coffee Mill for information on how to obtain service.