

PIONEER®

CENTRAL SPLIT AIR CONDITIONER

Installation Manual

HIGH EFFICENCY AIR HANDLER

Models:

- DR024GHFD18HT2
- DR036GHFD18HT2
- DR048GHFD18HT2
- DR060GHFD18HT2

-
- R-410A REFRIGERANT
 - 208/230V, 1 Phase, 60Hz
 - 18 SEER

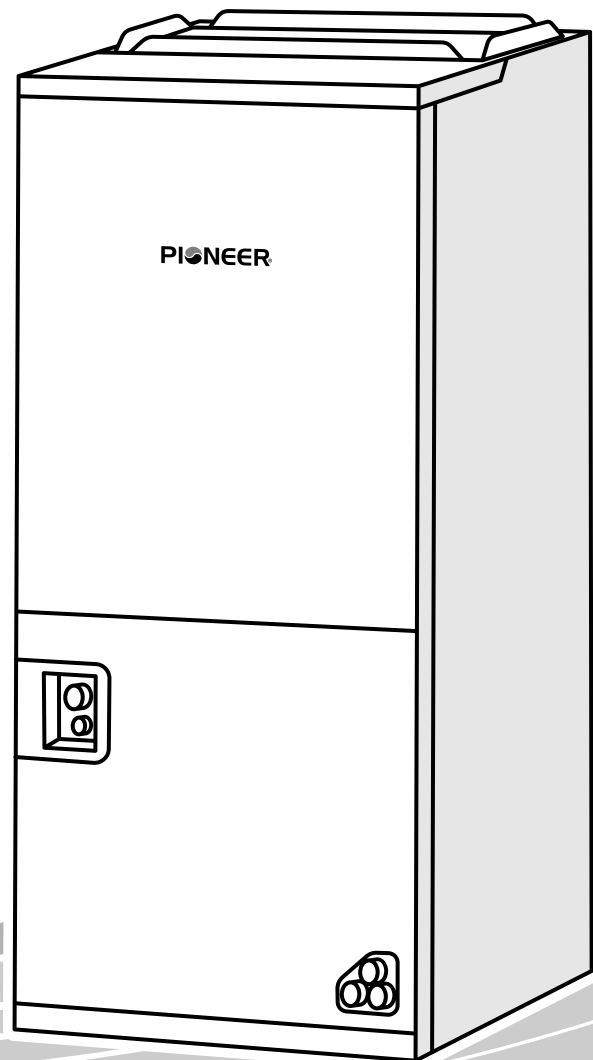

IMPORTANT NOTICE: Thank you very much for purchasing this Air Conditioner. Please read this manual carefully before installing or operating your new air conditioning system. Be sure to save this manual for future reference.

This page intentionally left blank.

Safety Precautions	1
Components of the Air Conditioner	3
Troubleshooting	4
Filter Cleaning	4
Installation and Maintenance	5
1. Safety Notice	5
2. Installation of the Indoor Unit	5
2.1. Initial Check	5
2.2. Installation Location.....	6
2.3. Installation	6
2.4. Air Duct.....	6
3.Special Instructions for Down-flow Conversion	7
4.Refrigerant Pipe	8
4.1. Pipe Material.....	8
4.2. Piping Connection.....	8
5.Drain Piping.....	8
6.Electrical Wiring	9
6.1. Electrical Installation.....	9
6.2. Change of Static Pressure.....	10
7.Test Run	10
8.TXV Replacement Information	11
9.Electric Heat Kit Selection Table.....	11

Safety Precautions

Alert Symbols:

 **DANGER** : This symbol refers to a hazard which can result in severe personal injury or death.

 **WARNING** : This symbol refers to a hazard or an unsafe practice which may result in severe personal injury or death.

 **CAUTION** : This symbol refers to a hazard or an unsafe practice which may result in minor personal injury, product, or property damage.

NOTE : This mark refers to the remarks and instruction to the operation, maintenance and service.

- Installation, maintenance, and repair of this unit must be performed by qualified, licensed service personnel.
- Read these instructions thoroughly before installation or operation. Failure to follow these instructions may result in improper installation, service or maintenance, possibly resulting in fire, electrical shock, property damage, personal injury or death.
- Before installation, check if the voltage of the power supply at installation site is the same as the voltage shown on the nameplate.

 **DANGER**

- Do not perform any alterations to this product, otherwise, it can cause water leakage, breakdown, short circuit, electric shock, fire, etc.
- Piping, welding, and other such work should be carried out far away from the flammable and explosive materials, including air conditioner refrigerant, to guarantee the security and safety of the site.
- To protect the air conditioner from heavy corrosion, avoid installing the outdoor unit in a place in which sea water can splash directly onto it, or in sulfurous air, such as near a spa. Do not install the air conditioner where excessively high heat-generating objects are located.

 **WARNING**

- If the supply cord is damaged, it must be replaced by the factory or its service department in order to avoid danger.
- The place where this product is installed must have reliable electrical grounding facilities and protections. Please do not connect the grounding of this product to any various sorts of air feeding ducts, drain pipes, lightning protection facilities, as well as other piping lines, to avoid electric shock and damage caused by external factors.
- All wiring must be done by a qualified electrician. All wiring operations must be conducted according to the local electrical codes.
- It is strongly advised to consider the capacity of the electric current of the available electrical meter and socket before installation.
- The power source of where this product is installed should have an independent leakage protection device. An electric current over-load protection device should also be provided for this product.
- Never use gasoline or other inflammable gas near the air conditioner to avoid danger. When any abnormality, like burnt smells, deformation, fire, smoke, etc. is discovered, immediately cut off the main power supply to the air conditioner and contact the dealer.
- The first 6 inches of supply air plenum and duct work must be constructed of sheet metal, as required by NFPA 90B.
- The supply air plenum or duct must have a solid sheet metal bottom piece directly after the air handler unit, with no opening, registers or flexible air ducts located in it. If flexible supply air ducts are used, they may be located only in the side walls of the rectangular plenum, a minimum of 6 inches from the solid bottom.

- **Read this manual carefully before using this air conditioner. If you still have any difficulties or problems, consult your dealer for further assistance.**
- **The air conditioner is designed to provide you with comfortable room conditions. Use this unit only for its intended purpose, as described in this instruction manual.**

WARNING

PROPOSITION 65:

- This appliance contains fiberglass insulation. Respirable particles of fiberglass are known in the State of California to cause cancer.
- All manufacturer products meet current federal OSHA Guidelines for safety. California Proposition 65 warnings are required for certain products, which are not covered by the OSHA standards.
- California's Proposition 65 requires warnings for products sold in California that contain or produce any of over 600 listed chemicals known to the State of California to cause cancer or birth defects, such as fiberglass insulation, lead in brass, and combustion products from natural gas.
- All "new equipment" shipped for sale in California will have labels stating that the product contains and/or produces Proposition 65 chemicals. Although we have not changed our processes, having the same label on all our products facilitates manufacturing and shipping. We cannot always know "when, or if" products will be sold in the California market.
- You may receive inquiries from customers about chemicals found in, or produced by, some of our heating and air conditioning equipment, or found in natural gas used with some of our products. Listed below are those chemicals and substances commonly associated with similar equipment in our industry and other manufacturers:
 - Glass Wool (Fiberglass) Insulation
 - Carbon Monoxide(CO)
 - Formaldehyde
 - Benzene
- More details are available at the websites for OSHA (Occupational Safety and Health Administration), at www.osha.gov and the State of California's OEHHA (Office of Environmental Health Hazard Assessment), at www.oehha.org. Consumer education is important since the chemicals and substances on the list are found in our daily lives. Most consumers are aware that products present safety and health risks, when improperly used, handled and maintained.

CAUTION

- Do not turn the air conditioner on and off from the main power switch. Use the ON/OFF operation button unless not possible.
- Do not stick anything into the air inlet and air outlet of both the indoor and outdoor units. This is dangerous as the fan could be rotating at a high speed.
- Do not cool or heat the room to extreme temperatures if babies or invalids are present.
- Type and rating of circuit breakers / ELB are detailed below.
- The method of connection of the appliance to the electrical supply and interconnection of separate components are detailed below.
- The information of dimensions of the space necessary for correct installation of the appliance, including the minimum permissible distances to adjacent structures, is detailed below.
- The range of external static pressures for ducted appliances is detailed below.
- Ensure that the blower motor support is tight (3-motor mounting bolts). Next, check to see if the wheel is tightly secured to the motor shaft before operation of the unit.

NOTE:

Storage Conditions: Temperature -13~140°F (-25~60°C)
Humidity 30% ~ 80%

Components of the Air Conditioner

Indoor Unit

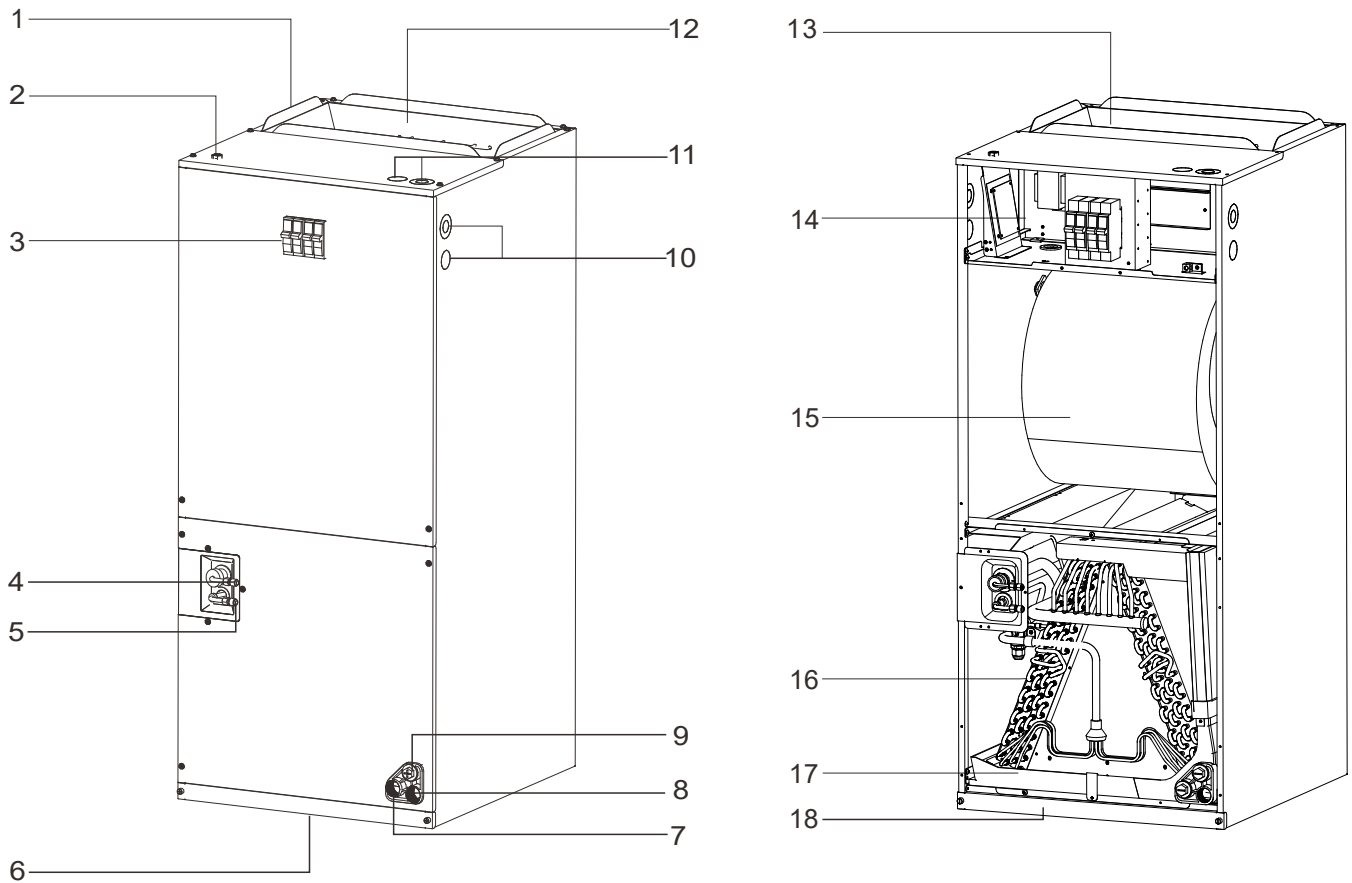

1. Air Outlet Flange
2. Low Voltage Connection (for 24V)
3. Circuit Breaker Switch (Optional)
4. Refrigerant Pipe (Gas)
5. Refrigerant Pipe (Liquid)
6. Air Inlet
7. Auxiliary Drainage Hole
8. Drainage Hole
9. Auxiliary Drainage Hole
10. High Voltage Connection
11. High Voltage Connection
12. Air Outlet

13. Auxiliary Heater (Optional)
14. Electronic Control Box
15. Fan Volute
16. Evaporator
17. Drainage Pan
18. Filter Cover

NOTE: These figures are based on external views of the standard model.
Consequently, the shape may differ for the air conditioner model you have selected.

Troubleshooting



If drainage water overflows from the indoor unit, cease all operation and contact your dealer. If you smell or see white smoke coming out of the unit, turn OFF the main power supply and contact your dealer.

1. If Issues Persist

If the issues continue even after checking the following, contact your dealer and have the following information ready:

- (1) Unit Model Name
- (2) Description of the Issue

2. No Operation

Check whether the SET TEMP is set to the desired temperature.

3. Not Cooling or Heating Properly

- Check for obstruction of air flow at the outdoor or indoor units.
- Check if there are too many heating sources in the room.
- Check if the air filter is clogged with dust or other obstructions.
- Check if doors or windows are open.
- Check if the ambient temperature conditions are within the operation range.

4. The Following Are Not Abnormal:

• Odor from Indoor Unit

Unpleasant odor diffuses from indoor unit after a long period of time. Clean the air filter and panels and ensure that there is sufficient ventilation.

• Sounds from Moving Parts

When starting or stopping the system, a sound might be made. However, this is likely due to thermal deformation of plastic parts. If so, it is not abnormal.

• Steam from Outdoor Heat Exchanger

During the defrosting operation, ice on the outdoor heat exchanger melts, resulting in steam.

• Dew on Air Panel

When the cooling operation operates for an extended period of time under high humidity conditions, dew can form on the air panel.

• Refrigerant Flow Sound

While the system is starting or stopping, the sound of refrigerant flowing may be heard.

Air Filter

Filter Cleaning (Filter Not Factory-Installed)

Please replace or clean the filter regularly, as dust can gradually accumulate onto the surface of the filter after a long period of time.

Follow these steps to properly replace the filter:

After removing the two manual bolts, take down the filter cover and pull out the filter from the case, then insert the new one into the case along the filter rail. Finish by fixing the filter cover with manual bolts.

Model	Filter size (LxWxH) in.
24K/36K	20x18x1
48K/60K	22x20x1

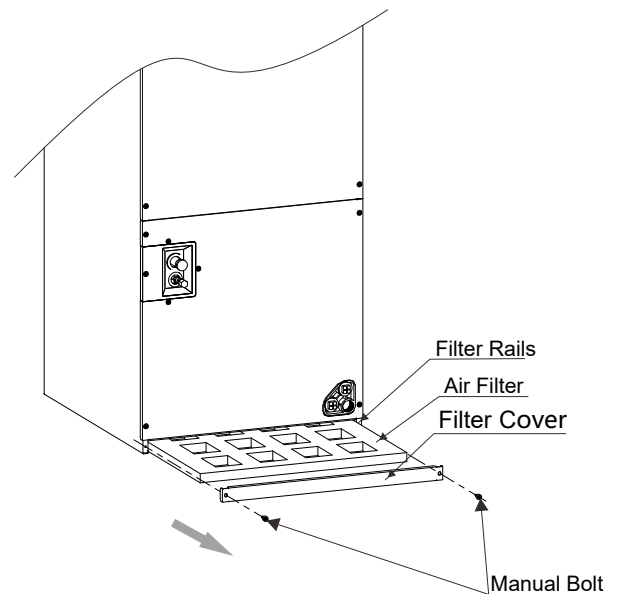

1. Safety Notice and Tips

▲ WARNING

- Install the air conditioner on a solid base that can support the unit's weight. (An inadequate base or incomplete installation may cause injury, due to falling off from the base.)
- Electrical work should be carried out in accordance with the installation manual and the local and national electrical wiring rules or codes.
(Insufficient capacity or incomplete electrical work may cause electrical shock or fire.)
- Be sure to use a dedicated power circuit. (Never use a power supply shared by another appliance.)
- For wiring, use a cable long enough for the entire distance, and do not use an extension cord.
- Do not put other loads on the power supply, and ensure a dedicated power circuit is used.
- Use the specified types of wires for electrical connections between the indoor and outdoor units. (Firmly clamp the interconnecting wires so that the terminals receive no external stress.)
- Incomplete connections or clamping may cause terminal overheating or fire.
- After establishing connection between all the wires, secure the cables to prevent undue force on the electrical covers or panels. (Install covers over the wires. Incomplete cover installation may cause terminal overheating, electrical shock, or fire.)
- There is 100PSIG of high pressure nitrogen in the evaporator, that must be released it first before installation. It indicates that the evaporator is sealed if nitrogen escapes, otherwise, it can indicate an evaporator leak.
- When installing or relocating the system, be sure to keep the refrigerant circuit free from air (Air in the refrigerant circuit may cause an abnormal pressure rise or rupture, resulting in injury or damage.)
- If any refrigerant leakage occurs during the installation work, ventilate the room liberally.
- After all installation is completed, ensure that no refrigerant leaks. (The refrigerant can produce toxic gas if exposed to flames.)
- When carrying out piping connections, do not allow air substances other than the specified refrigerant to enter the refrigeration cycle, else it can cause decreased performance, abnormally high pressure in the refrigeration cycle, explosion, and injury.)
- Ensure that the installation has a proper ground-earth connection. Do not ground the unit to a utility pipe, arrester, or telephone grounding. Incomplete grounding may cause electrical shock. (A high surge current from lightning or other sources may cause damage to the air conditioner.)
- An earth leakage circuit breaker may be required depending on the site condition, to prevent electrical shock.
- Disconnect the power supply before wiring, piping, or checking the unit.

2. Installation of the Indoor Unit

2.1 Initial Check

▲ CAUTION

- When moving the unit after unpacking, exercise caution to not exert any pressure on other parts, especially the refrigerant piping, drain piping and flange parts.
- Wear personal protective equipment when installing the unit.

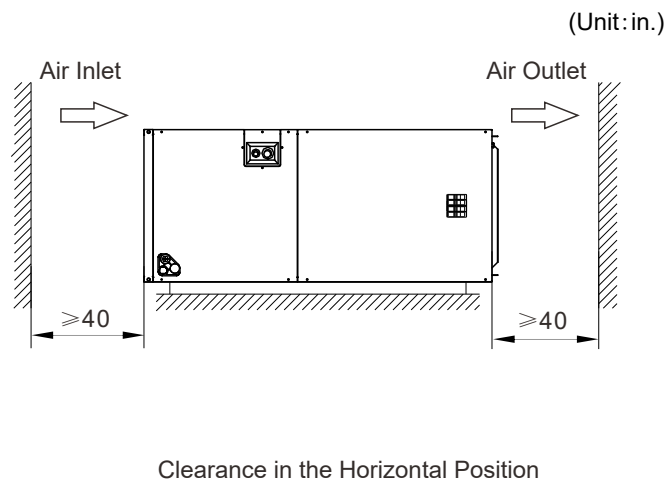
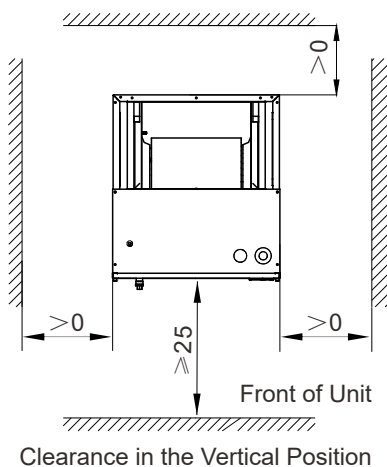

2.2 Installation Location

Before selecting the installation site, obtain all required permissions and follow the below parameters:

- Optimal air distribution is ensured.
- The air path is not blocked or obstructed.
- Condensation is able to drain properly.
- Ensure sufficient clearance for future maintenance and servicing.
- Piping between the indoor and outdoor units should be within the allowable limits. (Refer to the installation of the outdoor unit manual)
- The indoor unit, outdoor unit, power supply wiring, and transmission wiring should be kept at least 3 feet away from televisions and radio, which prevents image interference and noise in those electrical appliances. (Noise may be generated depending on the conditions under which the electric wave is generated, even if this distance is maintained.)
- Do not install the indoor unit in a machinery shop or kitchen where vapors from oils or any mists can reach the indoor unit. Any oils will collect on the heat exchanger, thereby reducing the performance of the indoor unit, and may deform, and in the worst case, break the plastic parts of the indoor unit.
- When the unit is installed in a hot and humid place, it is recommended to insulate the cabinet exterior and to use auxiliary drain pans.
- If installed above a finished living space, an auxiliary drain pan (as required by many building codes) must be installed under the entire unit, and its condensate drain line must be routed to a location such that the user will see the condensate discharge.

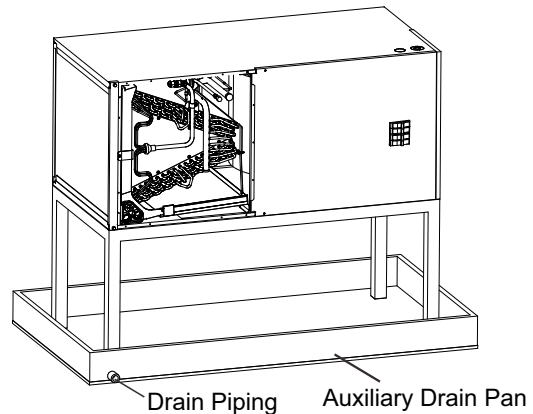

2.3b: Horizontal Right Installation (or hanging from ceiling)

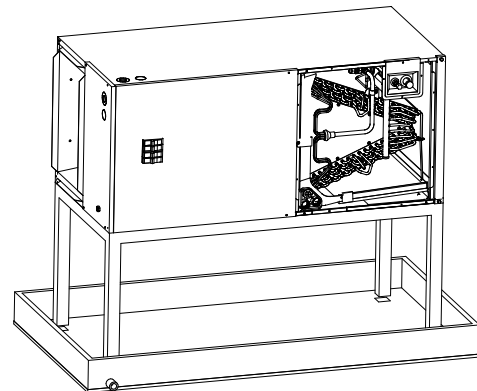

2.3c: Horizontal Left Installation (or hanging from ceiling)

The upright installation method is selected by default. When the unit is horizontal-right mounted, rotate it to the right by 90 degrees, as shown in the image for horizontal-right installation (2.3b).

When the unit is horizontally-left mounted (2.3c), the following steps are required.

- 1). Disassemble the lower panel and the sealed plate.
- 2). Disassemble the retaining clips for the evaporator so that the evaporator can be pulled out along the lead rail easily.
- 3). Rotate the evaporator by 180 degrees and insert it into the upper side of the lead rail.
- 4). Rotate the unit to the left by 90 degrees, as shown in the image "2.3b: Horizontal-Left Installation".
- 5). Reinstall the sealed plate and the lower panel.

2.4 Air Duct

Field duct work must comply with the National Fire Protection Association NFPA 90/NFPA 90B, and any applicable local ordinances.

▲ WARNING

Do not, under any circumstances, connect return duct work to any other heat producing device such as a fireplace insert, stove, etc. Unauthorized use of such devices may result in fire, carbon monoxide poisoning, explosion, personal injury or property damage.

2.3 Installation

NOTE:

These appliances are designed for indoor installation only.

The indoor units can be installed in one of the upright, horizontal left, or horizontal right orientations as shown in the Figures below.

Minor field modifications are necessary to convert to horizontal left.

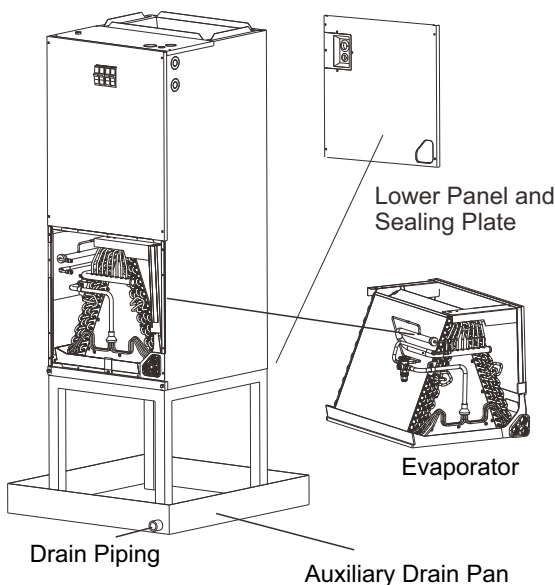

2.3a: Upflow Installation

3. OPTIONAL: Downflow Conversion Instructions

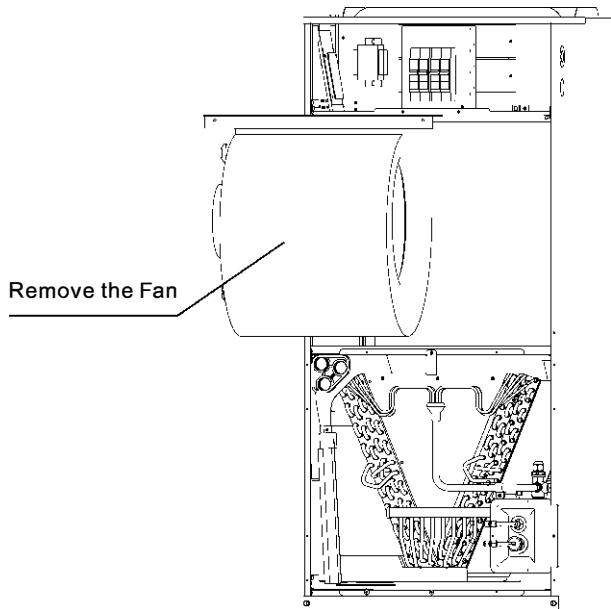
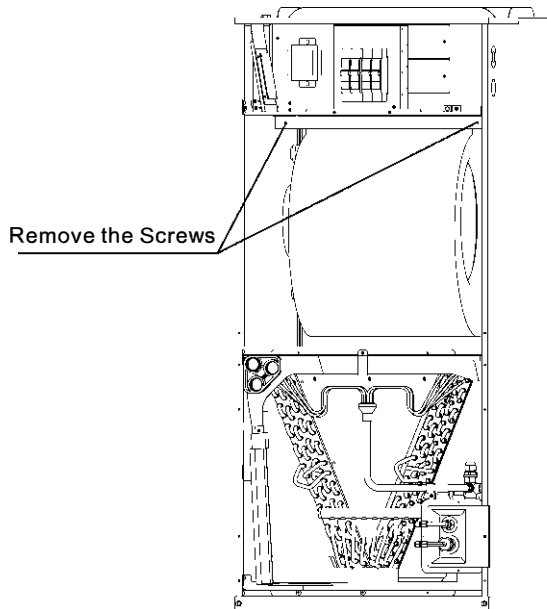

Downflow Installation Steps:

1. When the equipment needs to be installed as downflow, first follow steps 1), 2), 3) of "Horizontal left installation" (2.3c) to complete the rotating installation of the evaporator;
2. Remove the grounding wire of the motor, unplug the power cord on the power supply board, and pull it out from the wire hole of the electrical box;
3. Remove the two screws fixing the fan;
4. Pull the fan out of the guide rail and place it on a flat surface for easy operation;
5. Take out the sponge in the accessories bag and paste the sponge to the surface of the fan according to the scheme shown in the right picture;
6. Reinstall the fan back to the device by following the reverse steps of steps 4, 3, and 2 for the inverted installation, connect the grounding wire and power cable correctly, and fix the upper and lower panels;
7. Rotate the equipment by 180 degrees to convert the air outlet to downflow.

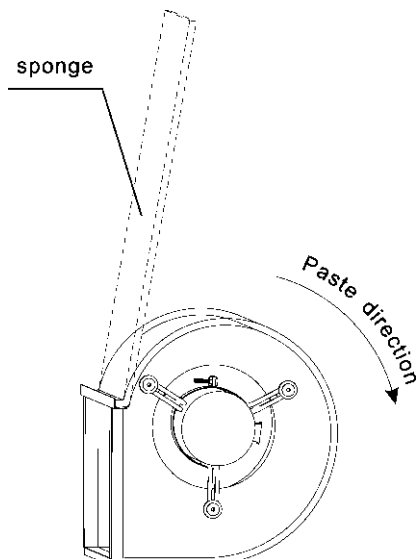

New Downflow Position

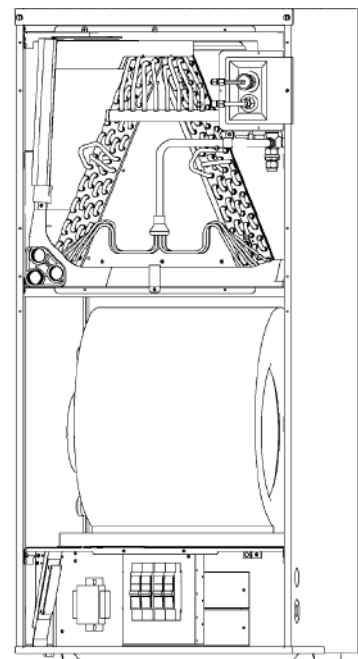

Sheet metal ductwork run in unconditioned spaces must be insulated and covered with a vapor barrier. Fibrous ductwork may be used if constructed and installed in accordance with SMACNA Construction Standard on Fibrous Glass Ducts. Ductwork must comply with National Fire Protection Association as tested by U/L Standard 181 for Class I Air Ducts. Check local codes for requirements on ductwork and insulation.

The duct system must be designed within the range of external static pressure the unit is designed to operate against. It is important that the system airflow is adequate. Ensure that the supply and return duct work, grills, special filters, accessories, etc. are accounted for in total resistance calculations.

4. Refrigerant Pipe

⚠ DANGER

Use refrigerant spec. according to the outdoor unit nameplate. When carrying out the leakage check and test, do not mix in any oxygen, acetylene, or any sort of flammable/reactive gas, as these gases may result in explosion. It is recommended to use nitrogen to perform these procedures.

4.1 Pipe Material

- (1) Prepare the copper pipe on-site.
- (2) Choose dust-free, non-humid, clean copper pipe. Before installing the pipe, use nitrogen or dry air to blow away any dust or impurities on the pipe.
- (3) Select the copper piping according to outdoor manual.

4.2 Piping Connection

- (1) The connection positions of the pipe are shown in Fig. 4.1.

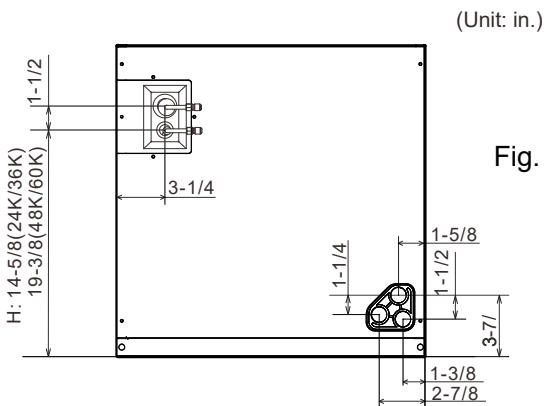

Fig. 4.1.

Fig. 4.1. Connection Positions of the Piping

Refer to the "Outdoor Unit Installation Instructions" for details on piping size selection, piping installation, and charging information.

The coil is shipped filled with Nitrogen. Evacuate the system before charging with refrigerant. Install refrigerant lines so that it does not block service access to the front of the unit.

Nitrogen should flow through the refrigerant lines while brazing.

Use a wet rag or an approved heat paste to protect the TXV sensing bulb during the brazing process.

5. Drain Piping

The indoor units has a field supplied with primary and secondary 3/4-in. NPT drain connections.

When making drain fitting connections to the drain pan, use a thin layer of Teflon paste, silicone, or Teflon tape and install. Hand-tighten afterwards.

When making drain-fitting connections to drain pan, do not over-tighten.

All horizontal drain pipes must be pitched downward away from the unit at a minimum of 1/8" per foot to provide problem-free drainage.

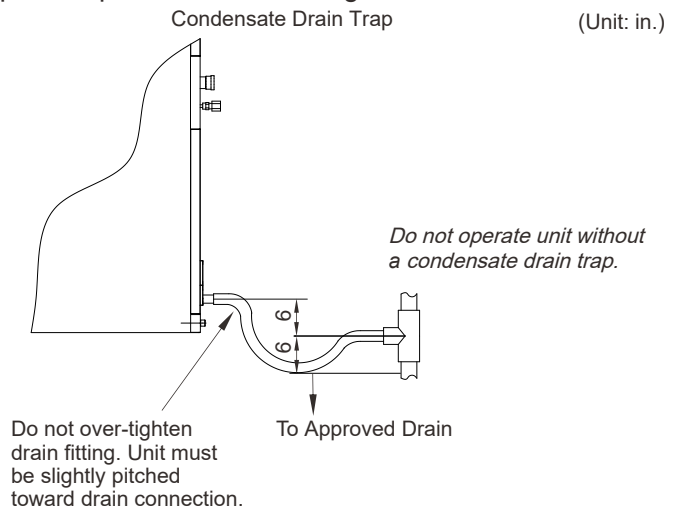

Do not connect the drain pipes directly to sewage pipes, to avoid ammonia odors. The ammonia in the sewage can enter the indoor unit through the drain pipes and corrode the heat exchanger.

Do not twist or bend the drain hose, as excessive force is applied during twisting or bending and may also cause leakage.

The drain line should be insulated where necessary, to prevent sweating and damage due to condensate forming on the outside surface of the pipe.

Test condensate drain pan and drain pipe after installation is complete. Keep the case horizontal (horizontal left or horizontal right) to ensure a smooth drainage, or incline the case 0.5° to the drainage hole, making it the lowest point for draining. Pour water into drain pan, enough to fill drain trap and line. Check to make sure drain pan is draining completely, no leaks are found in drain pipe fittings, and water is draining from the termination of the primary drain pipe.

NOTES:

If unit is located in or above a living space where damage may result from condensate overflow, a field-supplied, external condensate pan should be installed underneath the entire unit, and a secondary condensate line (with appropriate trap) should be run from the unit into the pan. Any condensate in this external condensate pan should be drained to a designated place. The owner of the structure must be informed that when condensate flows from the secondary drain or external condensate pan, the unit requires servicing, or water damage will occur. Install traps in the condensate lines as close to the coil as possible.

6. Electrical Wiring

6.1. Electrical Installation



- Before proceeding with electrical connections, ensure that power supply is as specified on the unit rating plate. See unit wiring label for proper field high and low-voltage wiring. Make all electrical connections in accordance with the NEC and any local codes or ordinances that may apply. Refer to the NEC(USA) or CSA (Canada) for wire sizing. Use properly-sized copper wire only.
- Every installation must include an NEC(USA) or CSA (Canada) approved over-current protection device.



Disconnect all power before servicing or installing this unit.

To avoid electrical shock, fully ensure that the air conditioner is properly grounded.

All routing of electrical wiring must be made through provided electrical knockouts. Do not cut, puncture, or alter the cabinet for electrical wiring.

Knockouts are provided on the indoor unit top panel and sides of the cabinet to allow for entry of the supply voltage conductors. If the knockouts on the cabinet sides are used for electrical conduit, an adapter ring must be used in order to meet UL 1995 safety requirements. An MEC or CEC approved strain relief is to be used at this entry point. Some codes/municipalities require the supply wire to be enclosed in conduit.

Consult your local codes for further details.

Wiring Diagram

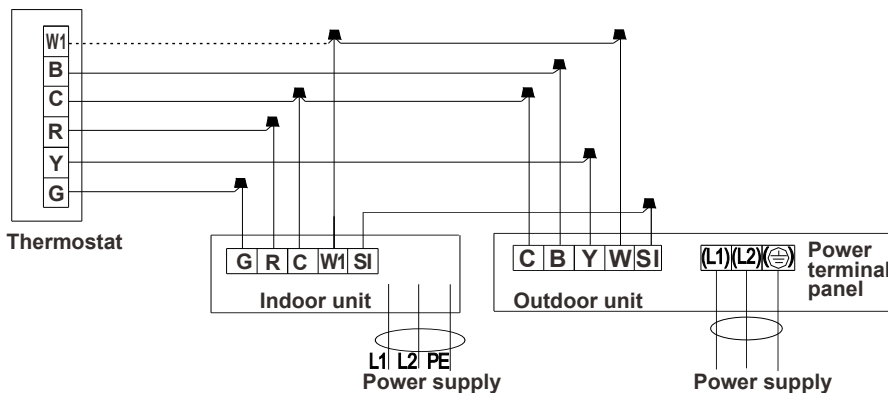

If the matching outdoor (condensing) unit does not have an S1 terminal, then ignore the S1 to S1 connection.

NOTE:

- (1) Do not connect dashed line when electric heater is not used.
- (2) Wiring must be performed according to wiring diagram that is posted on indoor unit.
- (3) The SI wire between the indoor and outdoor units is not mandatory, especially when the outdoor unit is connected to an indoor unit of a different brand. It is more energy-efficient when the outdoor unit is connected to a Pioneer indoor unit via SI wire. However, it still can run without it.
- (4) Since the thermostat is locally provided, the terminal block in the diagram may differ from the actual one. The letter Y is the same as Y1.
- (5) Use standard thermostat wire to make a direct connection between the S1 terminal of the outdoor unit to the indoor S1 connection of the indoor unit. This will add to this system set the ability to digitally communicate between the indoor and outdoor sections to change the indoor unit's fan speed automatically based on operational heat/cool loads.

Electrical data

Model (Capacity)	Power Supply	ELB		Power Source Cable Size	Transmitting Cable Size	Thermostat Signal Size	Fuse or Circuit Breaker (A)
		Rated Current (A)	Nominal Sensitive Current (mA)				
24K/36K	208/230V ~/60Hz	15	30	3×16AWG	5×16AWG	5×18AWG/ 6×18AWG	15
48K/60K	208/230V ~/60Hz	15	30	3×16AWG	5×16AWG	5×18AWG/ 6×18AWG	15

Max. Running Current (A): REFER TO NAMEPLATE





NOTE :

- (1) Follow local codes and regulations when selecting field wires. All the above are the minimum wire sizes.
- (2) When transmission cable length is longer than 262ft. (80m), a thicker wire size should be selected.
- (3) Install main switch and ELB for each system separately. Select a high-response type ELB that activates within 0.1 second.
- (4) If auxiliary heater is required and already installed on indoor unit, power source cable should be installed separately and the size should be selected in accordance with UL standards.

6.2 Change of Static Pressure

The static pressure can be selected by changing the *Dip Switches* on the electrical board.

Static Pressure Setting:

Dip Switch S2 Setting	Blower Speed Tap	Fan Speed Select	Static Pressure (W.C.[kPa]) 24K	Static Pressure (W.C.[kPa]) 36K	Static Pressure (W.C.[kPa]) 48K/60K
ON  OFF 1 2 3 4	2	Medium Low (Default setting)	0.18[0.045]	0.24[0.057]	0.28[0.07]
ON  OFF 1 2 3 4	3	Medium	0.25[0.08]	0.4[0.1]	0.4[0.1]
ON  OFF 1 2 3 4	4	Medium High	0.58[0.145]	0.58[0.145]	0.58[0.145]
ON  OFF 1 2 3 4	5	High	0.8[0.2]	0.8[0.2]	0.8[0.2]

NOTE: Symbol “ ■ ” indicates the position of the dip switch.
 Symbol “ □ ” indicates any position of ON or OFF.

7. Test Run

Please perform the test run according to the installation manual of the outdoor unit.

8. TXV Replacement Information

Please follow the steps below when replacing the TXV:

1. Disassemble the front panel.
2. Take the thermal bulb down by undoing the copper strips around it.
3. Weld the pressure pipe off from the gas pipe with a welding gun. Be careful not to burn the gas pipe.
4. Weld the TXV off from the liquid pipe with a welding gun. Be careful not to burn the liquid pipe.
5. Wrap the new TXV with a piece of wet cloth to prevent it from getting overly hot and connect the nitrogen flow to liquid pipe to prevent it from being oxidized. Weld the TXV to the liquid pipe, and pay attention to the direction of the TXV, then weld the pressure pipe to the gas pipe.
6. When the pipe cools down after welding, connect it with 150PSI nitrogen equipment and test and examine if leakage occurs.
7. Fix the thermal bulb to the gas pipe with copper strips and perform necessary insulation work.
8. Evacuate the unit, start up the system, and set the unit to start cooling operation.
9. When the unit has operated for 20 minutes, adjust the TXV superheat to 6°F.
10. When the unit has operated for another 20 minutes, examine whether the superheat is appropriate and record the figures afterwards.

9. Electric Heat Kit Selection Table

Electric Heat Kit Model	Air Handler Model	Electric Heat (kW)	MIN. Circuit Ampacity		MAX. Fuse or Breaker (HACR) Ampacity		Fan Speed Tap			
			230VAC	208VAC	230VAC	208VAC	2	3	4	5
21-4245-01	24K	5	28.3	25.9	30	30	●	●	●	●
21-4245-02		7.5	40.7	37.2	45	40	×	●	●	●
21-4245-03		10	53.2	48.5	60	50	×	×	●	●
21-4245-01	36K	5	29.8	27.4	30	30	●	●	●	●
21-4245-02		7.5	42.2	38.7	45	40	×	●	●	●
21-4245-03		10	54.7	49.9	60	50	×	×	●	●
21-4245-04		15	42.2+36.9	38.6+33.8	45+40	40+35	×	×	×	●
21-4245-01	48K/60K	5	31.8	29.4	35	30	●	●	●	●
21-4245-02		7.5	44.8	40.7	45	45	×	●	●	●
21-4245-03		10	56.7	51.9	60	55	×	×	●	●
21-4245-04		15	44.8+36.9	40.7+33.8	50+40	50+35	×	×	●	●
21-4245-05		20	56.7+49.9	51.9+45.2	60+50	60+50	×	×	×	●

●: available
×: unavailable

NOTE:

The heat kit is an optional part, and it must be connected to the power supply separately. It is recommended that electric heater kit should be installed in low temperature area or when long piping is used. Check if the heat kit is suitable for AHU 3-way position installation. Ampacities for MCA and Fuse/breaker including the blower motor. Heat pump systems require a specified airflow. Each ton of cooling requires between 350 and 450 cubic feet of air per minute(CFM).



This page intentionally left blank.

The design and specifications of this product are subject to change without prior notice as development continues. Consult with the sales agency or manufacturer for details. Refer to the equipment nameplate for all other applicable specifications.



is a registered trademark of Parker Davis HVAC International, Inc.

Parker Davis HVAC International, Inc.

3250 NW 107 Avenue, Doral, FL 33172 - USA

Tel : (305) 513-4488

Fax : (305) 513-4499

E-mail : info@pdhvac.com

Website: www.pdhvac.com

Pioneer product line, parts, and supplies are available online for convenient ordering at:

www.highseer.com

www.pioneerminisplit.com

Scan the below code to visit our support page where you can find more installation materials:

