

Keystone®

OWNER'S MANUAL

DEHUMIDIFIER



MODELS: KYSTD50AE/KYSTD50PAE

001152***

CONTENTS

IMPORTANT NOTE: Read the manual carefully. Make sure to save this manual for future reference. Illustrations in this manual are for explanatory purposes only, your actual product may look slightly different.

Safety Information	1
Control Panel	3
Operation Instruction	4
Using the Dehumidifier	5
Care and Cleaning	8
Troubleshooting	10



Keystone[®]

Product Warranty Card

Tarjeta de Garantia de Producto

Air conditioner warranty

Your product is protected by this warranty:

Your appliance is warranted by Haier. Any obligations for services and parts under this warranty must be performed by Haier Consumer Services or an authorized Haier servicer.

To contact a Customer Service Representative.

1-800-849-1112[®]

Garantía

Su producto está protegido por esta garantía:

Su producto está garantizado por Haier. Cualquier obligación de proporcionar servicio o repuestos establecida en esta garantía deberá ser cumplida por los Servicios al consumidor de Haier o por un representante autorizado de Haier.

Para comunicarse con un Representante de Servicio al Cliente.

1-800-849-1112[®]

SAFETY INFORMATION

IMPORTANT SAFETY INFORMATION



WARNING

For your safety, the information in this manual must be followed to minimize the risk of fire, electric shock or personal injury.

- Use this appliance only for its intended purpose as described in this Owner's Manual.
- This dehumidifier must be properly installed and grounded as described in this manual before it is used.
- Never operate this dehumidifier in an area that is likely to accumulate standing water. If this condition develops, for your safety disconnect the power supply before stepping into the water.
- Never unplug your dehumidifier by pulling on the power cord. Always grip plug firmly and pull straight out from the receptacle.
- Replace immediately all electric service cords that have become frayed or otherwise damaged. A damaged power supply cord must be replaced with a new power supply cord obtained from the manufacturer and not repaired. Do not use a cord that shows cracks or abrasion damage along its length or at either the plug or connector end.
- If the receptacle does not match the plug, the receptacle must be changed out by a qualified electrician.
- If the POWER SUPPLY CORD is damaged, it must be replaced by the manufacturer, its service agent or similarly qualified person in order to avoid a hazard.
- The appliance shall be installed in accordance with national wiring regulations.
- Turn the dehumidifier OFF and unplug it before cleaning.
- ARTT does not support any servicing of the dehumidifier. We strongly recommend that you do not attempt to service the dehumidifier yourself.
- For your safety, do not store or use combustible materials, gasoline or other flammable vapors or liquids in the vicinity of this or any other appliance.
- All dehumidifiers contain refrigerants, which under federal law must be removed prior to product disposal. If you are getting rid of an old product with refrigerants, check with the company handling disposal about what to do.
- Do not use outdoors.
- This dehumidifier is intended for indoor residential applications only. This dehumidifier should not be used for commercial or industrial applications.
- If the receptacle does not match the plug, the receptacle must be changed out by a qualified electrician.
- This appliance can be used by persons with reduced physical, sensory or mental capabilities or lack of experience and knowledge if they have been given supervision or instruction concerning use of the appliance in a safe way and understand the hazards involved.



CAUTION

Use of extension cords may lead to a risk of fire.
Could cause serious injury or death.

- DO NOT use an extension cord with this dehumidifier.
- DO NOT use surge protectors or multi-outlet adapters with this dehumidifier.

HOW TO CONNECT ELECTRICITY

- Do not, under any circumstances, cut or remove the third (ground) prong from the power cord. For personal safety, this appliance must be properly grounded.
- DO NOT use an adapter plug with this appliance.
- The power cord of this appliance is equipped with a 3-prong (grounding) plug which mates with a standard 3-prong (grounding) wall outlet to minimize the possibility of electric shock hazard from this appliance.
- Have the wall outlet and circuit checked by a qualified electrician to make sure the outlet is properly grounded.
- If you have a 2-prong wall outlet, it is your personal responsibility and obligation to have it replaced with a properly grounded 3-prong wall outlet.
- The dehumidifier should always be plugged into its own individual electrical outlet, which has a voltage rating matching the rating plate.
- This provides the best performance and also prevents overloading house wiring circuits, which could cause a fire hazard from overheated wires.

RECYCLING INFORMATION

For appliance recycling information, please contact your local municipal government or waste management service.



WARNING

Risk of Fire or Explosion. This unit contains flammable refrigerant. Additional safety precautions must be followed.

- Do not use means to accelerate the defrosting process or to clean, other than those recommended by the manufacturer.
- The appliance shall be stored in a room without continuously operating ignition sources (for example: open flames, an operating gas appliance or an operating electric heater).
- Do not pierce or burn refrigerant tubing. Be aware that refrigerants may not contain an odor.
- Keep ventilation openings clear of obstruction.
- When handling, installing, and operating the appliance, care should be taken to avoid damage to the refrigerant tubing.
- Do not drill holes in the unit.
Maintenance, cleaning, and service should only be performed by technicians properly trained and qualified in the use of flammable refrigerants.
- We do not support any servicing of the dehumidifier.
- Dispose of the dehumidifier in accordance with Federal and Local Regulations. Flammable refrigerants require special disposal procedures. Contact your local authorities for the environmentally safe disposal of your dehumidifier.

CONTROL PANEL

Appearance may vary by model.

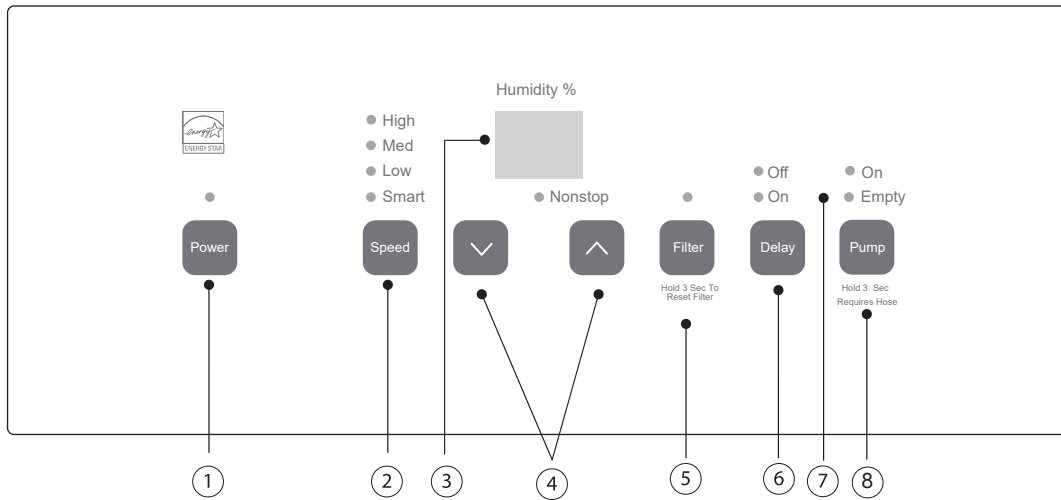





CONTROLS

#	ITEM	DESCRIPTION
1	Power Pad	<ul style="list-style-type: none"> Press to turn the dehumidifier ON and OFF.
2	Fan Speed Pad	<ul style="list-style-type: none"> Controls the fan speed. Press to select either High, Medium, Low, or Smart fan speed. Set the fan control to High for maximum moisture removal. When the humidity has been reduced and quiet operation is preferred, set the fan control to Medium or Low. The Smart Dry setting compares the set humidity level with the actual humidity and adjusts the fan speed automatically.
3	Display	<ul style="list-style-type: none"> Shows the set % humidity level while setting, then shows the actual (+/- 5% accuracy) room % humidity level.
4	Humidity Set Control Pads	<ul style="list-style-type: none"> The humidity level can be set within a range of 35% RH (Relative Humidity) to 80% RH (Relative Humidity) in 5% increments or at Nonstop for continuous operation. To set the unit for continuous operation, press the ⏴ pad until the "Nonstop" indicator light is illuminated. Note: If Nonstop is selected, the dehumidifier will operate continuously at its maximum dehumidification settings if attached to a hose to drain or until the bucket is full. For drier air, press the ⏴ pad and set to a lower percent value (%). For damper air, press the ⏵ pad and set to a higher percent value (%). When you first use the dehumidifier, set the humidity control to 45% or 50%. Allow at least 24 hours for the dehumidifier to achieve the humidity level. If you still have damper air than desired, set the humidity level to a lower setting or select Nonstop for maximum dehumidification.
5	Filter Timer	<ul style="list-style-type: none"> After 250 hours of operation, the Clean The Filter indicator light will glow to remind you to clean the filter. Remove the filter and clean it. Press and hold filter button for 3 seconds to reset the filter reminder. See the Care and Cleaning Section.

OPERATING INSTRUCTIONS

CONTROLS

#	ITEM	DESCRIPTION
6	Delay	<p>Delay Off</p> <ul style="list-style-type: none">• While the dehumidifier is operating press the Delay button.• Press the  /  buttons to select the number of hours you want the dehumidifier to continue to operate before turning OFF. <p>Note: After displaying the time, the Display will revert to showing the current humidity after 5 seconds have passed. Pressing the Delay button will display the number of hours left on the delay.</p> <p>Delay On</p> <ul style="list-style-type: none">• While the dehumidifier is off press the Delay button.• Press the  /  buttons to select the number of hours you want the dehumidifier to remain off before turning ON. <p>Note: The display will show the number of hours left until the dehumidifier turns on.</p> <p>Cancel the Delay</p> <ul style="list-style-type: none">• Press the Delay button once, the hours remaining on the Delay will appear on the display. Press the Delay button again and the Delay will be canceled.
7	Empty Indicator	<ul style="list-style-type: none">• The "Empty" indicator will blink when the bucket is ready to be emptied, or when the bucket is removed and/or not replaced in the proper position.
8	Pump (on some models)	<ul style="list-style-type: none">• Activates the internal pump function. Press for 3 seconds to activate the internal pump for automatic removal of condensate. The internal pump indicator light will remain illuminated after 3 seconds. Press to deactivate the pump. Before turning on the pump, ensure the hose connected.

OTHER FEATURES

Alarm

If the bucket is full or missing, an alarm will sound for about 10 seconds to remind you to empty and replace the bucket.

Auto Shut Off

The Water Level Control Switch shuts off the dehumidifier when the bucket is full, or when the bucket is removed and/or not replaced in the proper position.

NOTE: The fan and compressor will stop running as soon as the bucket is full or removed. The alarm will sound if the bucket is full or not replaced in the proper position after 3 minutes.

Auto Defrost

When frost builds up on the evaporator coils, the compressor will cycle off and the fan will continue to run until the frost disappears.

Power Outage

In the case of a power outage or interruption, the unit will automatically restart, at the settings last used, after the power is restored.

USING THE DEHUMIDIFIER

When first using the dehumidifier, operate the unit continuously for 24 hours.

Dehumidifier Operation

- Moist, humid air is drawn over a cold refrigerated dehumidifying coil. Moisture in the air condenses on this coil and drains into a bucket (or through a hose and drain).
- Dry, clean air is drawn through the condenser where it is heated and discharged out the top grille into the room.
- It is normal for the surrounding air to become slightly warmer as the dehumidifier operates.

Automatic Defrost

- When frost builds up on the evaporator coils, the compressor will cycle off and the fan will continue to run until the frost disappears.
- When the coil is defrosted, the compressor or fan will automatically restart, and dehumidifying will resume.

CHOOSING A LOCATION

A dehumidifier operating in a basement will have little or no effect in drying an adjacent enclosed storage area, such as a closet, unless there is adequate circulation of air in and out of the area.

- Do not use outdoors.
- This dehumidifier is intended for indoor residential applications only. This dehumidifier should not be used for commercial or industrial applications.
- Place the dehumidifier on a smooth, level floor strong enough to support the unit with a full bucket of water.
- Allow at least 18 inches of air space on all sides of the unit for good air circulation.
- Place the dehumidifier in an area where the temperature will not fall below 41°F (5°C) or above 90°F (32°C). The coils can become covered with frost at temperatures below 41°F, which may reduce performance.
- The suggested range of relative humidity is between 40% and 50%.

NOTE: Place the dehumidifier away from the clothes dryer.

- Use the dehumidifier to prevent moisture damage anywhere books or valuables are stored.
- Use the dehumidifier in a basement to help prevent moisture damage.
- The dehumidifier must be operated in an enclosed area to be most effective.
- Close all doors, windows and other outside openings to the room.

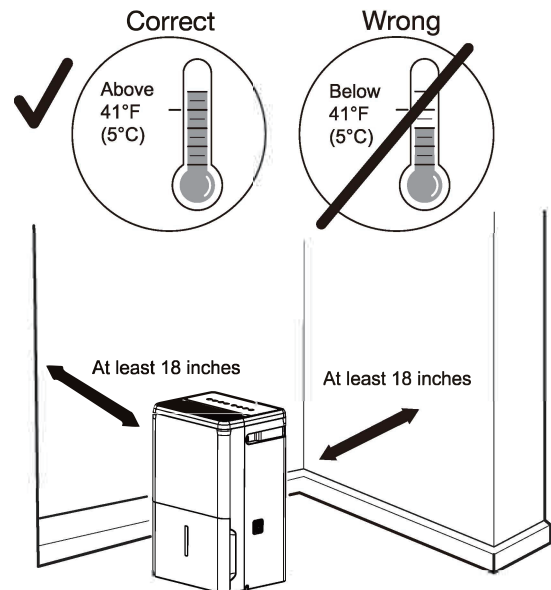

NOTE: The dehumidifier has rollers to aid placement, but it should only be rolled on smooth, flat surfaces. Do not attempt to roll the dehumidifier on carpet or over objects.

Bucket Operation

- DO NOT remove the foam piece in the bucket assembly. If removed, the dehumidifier will not work properly.

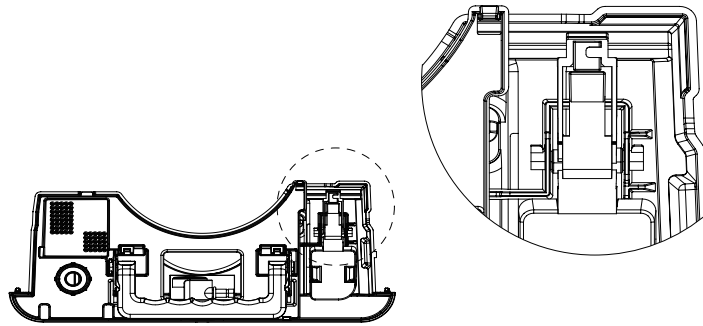

Always make sure the water bucket is locked into place on the humidifier.

Removing Collected Water

There are two ways to remove collected water, either using a bucket or using a hose for continuous drainage.

Use the Bucket

When the bucket is removed, the unit will shut off. Empty and replace bucket.

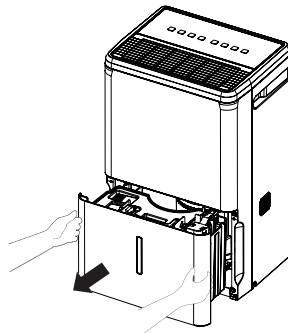

IMPORTANT: Do not use the hose if using the bucket to collect water. When the hose is connected, water will flow through it onto the floor instead of into the bucket.

NOTE:

- Do not remove the bucket while the dehumidifier is operating or if it has just stopped operating. This might cause some water to drip from the drain pan.
- The bucket must be in place and securely seated for the dehumidifier to operate.

Use a garden Hose(3/4-11.5NH)

Water can be automatically emptied into a floor drain by attaching a garden water hose (not included).

1. Remove the bucket from the front of the unit.
2. Open the drain cover on the side of the unit.

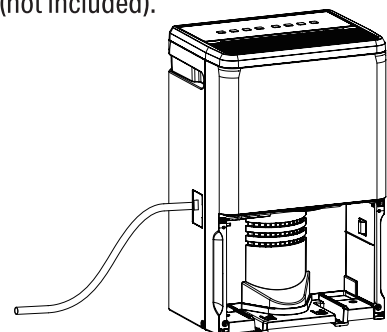

3. Thread a garden hose (not supplied) onto the nozzle, cut to length, and lead it to the floor drain.

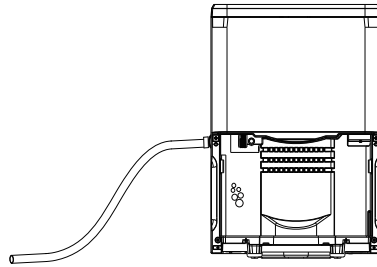

4. Replace the bucket in the unit.

NOTE: The bucket must be in place and securely seated for the dehumidifier to operate. The garden hose must run down from the dehumidifier to the floor drain.

Water Level

- The dehumidifier will turn off automatically when the bucket is full, or when the bucket is removed or not replaced in the proper position.
- The bucket must be replaced in the proper position for the dehumidifier to work. The empty indicator will blink, and the dehumidifier will not run if the bucket is not in the proper position.

Bucket Operation

- DO NOT remove the foam piece in the bucket assembly. If removed, the dehumidifier will not work properly.

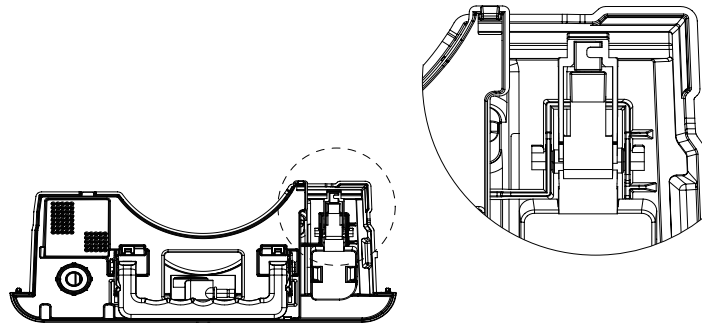

Removing Collected Water (Continued)

Use the internal pump (on some models)

Water can be automatically emptied into a remote location by attaching the included pump hose.

1. Attach the pump hose to the hose connector by pushing the tube fitting into the connector until it fits into place (should not be able to remove the hose when pulled).
2. Position the hose discharge to the desired location.
3. Make sure the pump is activated. To activate the pump, press and hold the Pump button for 3 seconds. The Pump indicator light will flash then remain illuminated once the 3 seconds are complete.

IMPORTANT: Make sure the condensate hose is properly connected and is not kinked, bent or cracked as this may cause water to flow onto the floor. Please ensure the bucket is empty before putting the unit into pump mode. The bucket must also be fully seated for the pump to work properly. Do not operate the machine if the room temperature is 41°F or below.

CARE AND CLEANING

NOTE: Maximum lift height is 16ft.

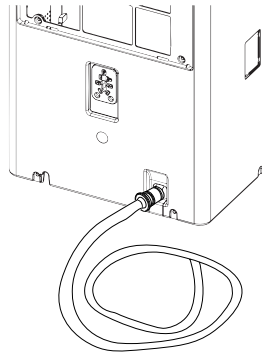

NOTE: DO NOT kink or crimp hose, as it can block water flow.

To Install Pump Hose (on some models): Push in hose and gently pull to make sure it is secure. Should not be able to be removed.

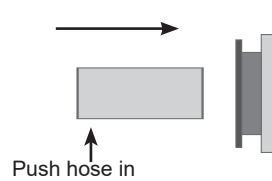

To Release Pump Hose: Hold the grey ring while pulling to remove.

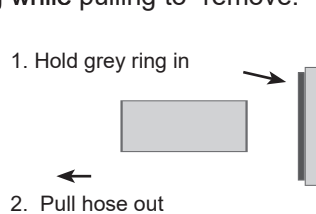

NOTE: DO NOT kink or crimp hose, as it can block water flow. Only use the hose included with the product for Pump mode.

Turn off the dehumidifier and remove the plug from the wall outlet before cleaning.

GRILLE AND CASE

Cleaning the Rear Grille

- Use a vacuum attachment or brush.

Cleaning the Case

- Use water and a mild detergent. Do not use bleach or abrasives.

WATER BUCKET

To Clean

- Every few weeks, clean the bucket to prevent growth of mold, mildew and bacteria.
- Partially fill the bucket with clean water and add a little mild detergent.
- Swish it around in the bucket, empty and rinse.

NOTE: Do not clean the water bucket by using a dishwasher.

To Remove

- Remove the bucket and pour out any water.

To Replace

- Slide the bucket into the dehumidifier.

NOTE: The bucket must be in place and securely seated for the dehumidifier to operate.

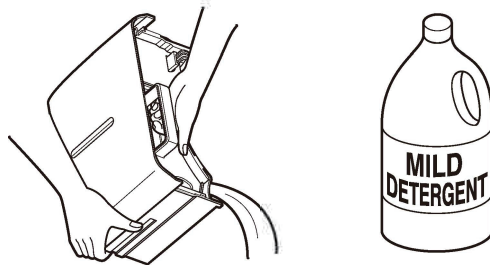

AIR FILTER

- The air filter behind the rear grille should be checked and cleaned at least every 250 hours of operation or more often, if necessary.
- After 250 hours of operation, the Filter indicator light will glow to remind you to clean the filter. Remove the filter and clean it. Replace the filter and press and hold the filter button for 3 seconds.

To Remove

- Remove the rear grille and the filter will be attached.

To Clean

- Clean the filter with warm, soapy water. Rinse and let the filter dry before replacing it.

NOTE: DO NOT put the filter in an automatic dishwasher.



CAUTION

DO NOT operate the dehumidifier without a filter because dirt and lint will clog it and reduce performance.

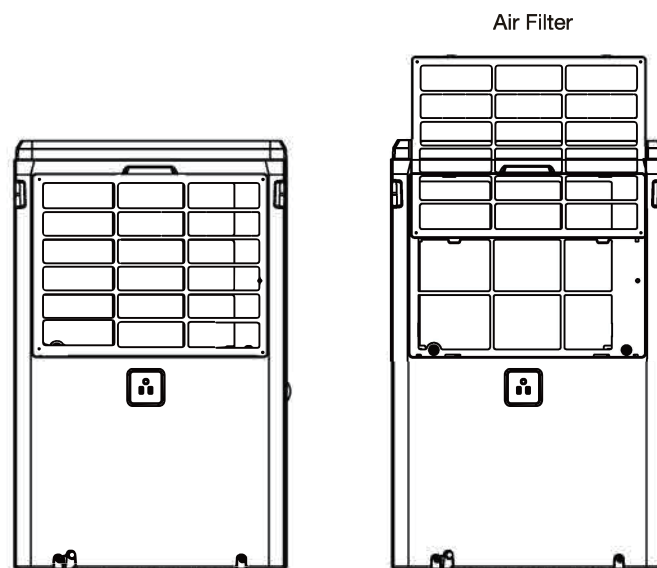

Appearance may vary by model.

TROUBLESHOOTING TIPS

Save time and money!

Review the charts on the following pages first and you may not need to call for service.

Problem	Possible Cause	What To Do
Dehumidifier does not start	The dehumidifier is unplugged.	Makes sure the dehumidifier's plug is pushed completely into the outlet.
	The fuse is blown/circuit breaker is tripped.	Check the house fuse/circuit breaker box and replace the fuse or reset the breaker.
	Dehumidifier has reached its set humidity level or bucket is full.	The dehumidifier automatically turns off when either condition occurs. Change to a lower setting or empty the bucket and replace properly.
	Bucket is not in the proper position.	The bucket must be in place and securely seated for the dehumidifier to operate.
	Power Failure.	There is a protective time delay (up to 3 minutes) to prevent tripping of the compressor overload. For this reason, the unit may not start normal dehumidification for 3 minutes after it turned back on.
Dehumidifier does not dry the air as it should	Did not allow enough time to remove the moisture.	When first installed, allow at least 24 hours to maintain the desired dryness.
	Airflow is restricted.	Make sure there are no curtains, blinds or furniture blocking the top or back of the dehumidifier. See the Choosing a Location section.
	Dirty Filter	See the Care and Cleaning section.
	The Humidity Control may not be set low enough.	For drier air, press the ▼ pad and set to a lower percent value (%) or at the Nonstop setting for maximum dehumidification.
	Doors and windows may not be closed tightly.	Check that all doors, windows and other openings are securely closed.
	Clothes dryer may be blowing moisture-laden air into the room.	Install the dehumidifier away from the dryer. The dryer should be vented to the outside.
	Room temperature is too low.	Moisture removal is best at higher room temperatures. Lower room temperatures will reduce the moisture removal rate. Models are designed to be operated at temperatures above 41°F (5°C).
Dehumidifier runs too much	Area to be dehumidified is too large.	The capacity of your dehumidifier may not be adequate
	Doors and windows are open.	Close all doors and windows to the outside.
Frost appears on the coils	Room temperature is below 41°F (5°C)	Please operate unit at temperatures above 41 F (5 C). Frost will usually disappear within 60 minutes. Under certain conditions, frost may appear on the coils of your dehumidifier at temperatures above 41°F (5°C). This is normal and frost will usually disappear within 60 minutes. See the Automatic Defrost section.
Fan noise	Air is moving through the dehumidifier.	This is normal.
Water on floor	Hose connection may be loose.	Check the hose connection. See the Removing Collected Water section.
	Intended to use the bucket to collect water, but a hose was attached	Disconnect the hose if using a bucket to collect water. See the Removing Collected Water section.
Bucket Full LED light flashing and alarm sounds while drain hose is connected	Drain hose not tight on fitting.	Check drain hose connection.
	Drain hose is kinked.	Ensure the drain hose is pointed straight down to the floor and is not kinked in anyway.
Bucket fills up when using drain pump (on some models)	Unit not in pump mode	Ensure pump is turned on and pump light is illuminated
	Pump hose not installed	Ensure pump hose is properly installed on back of unit
	Water level sensor issue	This may be caused by very humid conditions or error with float sensor. Check unit for a P1 error code on display. If this is present - turn off the unit, unplug unit for a few seconds, plug back in and turn on the unit to reset sensor. If this error continues to occur refer to warranty section for exchange options.



Keystone®

1-800-849-1112 | www.keystone-products.com