

# GAS COOKTOPS

- UHC P (75/95/125/36/48/965/1265)
- UHC PT (75/95/125/36/48/965/1265)
- UHC PM (95/125)
- UHC PMT (95/125)

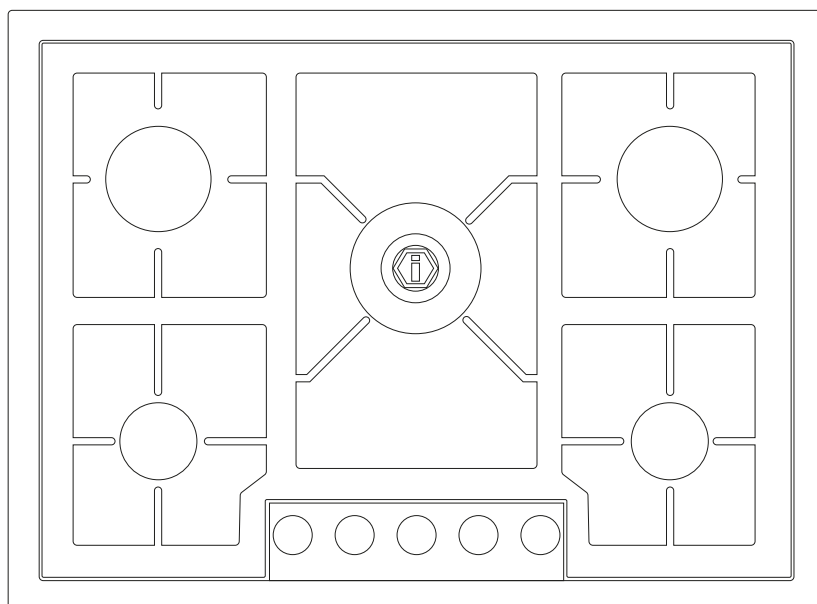

EN | User's manual

 **ILVE**





# IMPORTANT - PLEASE READ AND FOLLOW



- NEVER use this appliance as a space heater to heat or warm the room. Doing so may result in carbon monoxide poisoning (only for GAS cooking).
- Keep appliance area clear and free from combustible materials, gasoline and other flammable vapors and liquids.
- Before beginning, please read these instructions completely and carefully.
- Do not remove permanently affixed labels, warnings, or plates from the product. This may void the warranty.
- Please observe all local and national codes and ordinances.
- Please ensure that this product is properly grounded.
- The installer should leave these instructions with the consumer who should retain for local inspector's use and for future reference.
- Installation must conform with local codes or in absence of codes, the National Fuel Gas Code ANSIZ223.1/NFPA 54 latest edition. Electrical installation must be in accordance with the National Electrical Code, ANSI/NFPA70 latest edition and/or local codes. IN CANADA:
- Installation must be in accordance with the current CAN/CGA-B149.1 National Gas.
- Installation Code or CAN/CGA-B 149.2, Propane. Installation Code and/or local codes. Electrical installation must be in accordance with the current CSA C22.1 Canadian Electrical Codes Part 1 and/or local codes.
- Installation of any gas –fired equipment should be made by a licensed plumber. A manual gas shut-off valve must be installed in the gas supply line ahead of the oven in the gas stream for safety and ease of service.
- In Massachusetts: All gas products must be installed by a "Massachusetts" licensed plumber or gasfitter. A "T" handle type manual gas valve must be installed in the gas supply line to this appliance.
- The manufacturer will not be responsible for any damage to property or to persons caused by incorrect installation or improper use of the appliance.
- The manufacturer reserves the right to make changes to its products when considered necessary and useful, without affecting the essential safety and operating characteristics.
- This appliance has been designed for non-professional, domestic use only.
- This appliance must be used only for the purposes for which it was intended. Any other use is incorrect and therefore dangerous.
- Possible hazards may result from using this appliance for storage space.
- Appliances are not intended for manufactured (mobile) home installation.
- **WARNING: If the information in this manual is not followed exactly, a fine or explosion may result causing property damage, personal injury or death.**
- Do not store or use gasoline or other flammable vapors and liquids in the vicinity of this or any other appliance.
- WHAT TO DO IF YOU SMELL GAS:
  - Do not try to light any appliance.
  - Do not touch any electrical switch.
  - Do not use any phone in your building.
  - Immediately call your gas supplier from a neighbor's phone. Follow the gassupplier's instructions.
  - If you cannot reach your gas supplier, call the fire department.
- Installation and service must be performed by a qualified installer, service agency or the gas supplier. Keep appliance area clear and free from combustible materials, gasoline and other flammable vapors and liquids.

# IMPORTANT INSTRUCTION

- Keep appliance area clear and free from combustible materials, gasoline and other flammable vapors and liquids.
- Proper Installation – Be sure your appliance is properly installed and grounded by a qualified technician.

## All Appliances:

- CAUTION: Do Not Leave Children Alone - Children should not be left alone or unattended in area where appliance is in use.
- They should never be allowed to sit or stand on any part of the appliance. Do not store items of interest to children above or at the back of this appliance, as they could climb on the appliance to reach items and be injured.
- Wear Proper Apparel - Loose-fitting or hanging garments should never be worn while using the appliance.
- User Servicing - Do not repair or replace any part of the appliance unless specifically recommended in the manual.
- All other servicing should be referred to a qualified technician.
- Storage in or on Appliance - Flammable materials should not be stored near surface units.
- Do Not Use Water on Grease Fires - Smother fire or flame or use dry chemical or foam type extinguisher.
- Use Only Dry Potholders - Moist or damp potholders on hot surfaces may result in burns from steam. Do not let potholder touch hot heating elements. Do not use a towel or other bulky cloth.
- When using this appliance, do not touch grates, burner caps, burner bases or any other parts in proximity to the flame. These components may be hot enough to cause burns.
- Never leave this appliance unattended when in use. Boilovers and greasy spills may smoke or ignite
- Do not heat unopened food containers, such as baby food jars and cans. Pressure build-up may cause the container to burst and cause injury.
- Before performing service, shut off gas supply by closing the gas shut-off valve and shut off electricity to this appliance
- For safety when cooking, set burner controls so flame does not extend beyond the bottom of pan.
- Wear proper apparel. Loose-fitting or hanging garments should never be worn while using this appliance.
- Use extreme caution when moving a grease kettle or disposing of hot grease.
- Clean only those parts listed in this guide.
- Do not repair or replace any part of this appliance unless specifically recommended in literature accompanying this appliance.
- Do not obstruct the flow of air to ensure proper combustion and ventilation.
- IMPORTANT: Do not install a ventilation system that blows air downward toward this gas cooking appliance. This type of ventilation system may cause ignition and combustion problems with this gas cooking appliance resulting in personal injury or unintended operation.
- Never Use Your Appliance for Warming or Heating the Room.

# INSTALLATION INSTRUCTIONS

This appliance shall only be installed by an authorized person. This appliance shall be installed in accordance with the manufacturer's installation instructions, IMPORTANT: this appliance must be installed in accordance with the norms in force of the country concerned.

The installation of this appliance must conform to local codes and ordinances. In the absence of local codes, installations must conform to American National Standards, National Fuel Gas Code ANSI Z223.1-54-NFPA54

If local codes permit, a flexible metal appliance connection with the new AGA or CGA certified design, max. 5 feet (1,5m) long, ½" I.D. recommended for connecting this cooktop to the gas supply line. Do not bend or damage the flexible connector when moving the cooktop. The pressure regulator has ½" female pipe thread. You will need to determine the fitting required, depending on the size of your gas supply line, the flexible metal connector and the shutoff valve.

The appliance, when installed, must be electrically grounded in accordance with local codes or, in absence of local codes, with the National Electrical Code, ANSI/NFPA 70, CSA C22.1-02

The correct voltage, frequency and amperage must be supplied to the appliance from a dedicated, grounded circuit which is protected by a properly sized circuit breaker or time delay fuse. The proper voltage, frequency and amperage ratings are listed on the product rating plate.

The appliance and its individual shut off valve must be disconnected from the gas supply piping system any pressure testing of that system at test pressure in excess of ½psi (3,5kPa).

The appliance must be isolated from the gas supply piping system by closing its individual manual shutoff valve during any pressure testing of the gas supply piping system at test pressure equal to or less than ½psi (3,5kPa).

For use with a pressure regulator. The regulator supplied must be used with this appliance; it shall be properly installed in order to be accessible when appliance is installed in definitive position.

The gas appliance pressure regulator must be set for the gas with which the appliance is used.

This appliance can be used with Natural gas and LP Gas. It is shipped from the factory adjusted for use with Natural gas: CONVERSION FIXED ORIFICES ARE LOCATED IN THE LITERATURE PACK SUPPLIED WITH THE UNIT.

Injectors kit for the change of type of gas are contained inside the package jointly with the hob installation kit and Instruction booklet. The maximum inlet gas supply pressure incoming to the gas appliance pressure regulator is 20" water column (5kPa). The minimum gas supply pressure for checking the regulator setting shall be at least 1"w.c.(249Pa) above the inlet specified manifold pressure to the appliance (this operating pressure is 5"w.c. for Natural Gas and 10"w.c. for LP Gas). All opening and holes in the wall and floor, back and under the appliance shall be sealed before installation of the appliance.

ATTENTION: A manual valve shall be installed in an accessible location in the gas line external to the appliance for the purpose

of turning on or shutting off gas to the appliance.

WARNING: Do not use aerosol sprays in the vicinity of this appliance while it is in operation.

The appliances should not be installed with a ventilation system that blows air downward toward the range.

A ventilation hood is recommended (but not required) for use with the gas cooktop.

Warning! Before removing the appliance disconnect the electric power supply cable and close the relevant shut off valve. Make sure that the electric power supply cable is not damaged during cleaning / maintenance operation.

# GAS CONNECTION

The gas cooktop requires a 120 VAC, 60Hz electrical supply to operate the electronic ignition system. The service should have its own 15 amp circuit breaker. A ground fault circuit interrupter (GFCI) is not recommended and may cause interruption of operation. The cooktop is equipped with a power cord with a 3 prong grounding plug. To minimize shock hazard, the power cord must be plugged into a mating 3 prong grounded outlet, grounded to conform with the National Electrical Code, ANSI/NFPA 70 latest edition, or Canadian Electrical Code (CSA) and all local codes and ordinances. Refer to the illustration below. **IMPORTANT NOTE:** Do not ground to a gas pipe.

## Grounded wall Outlet

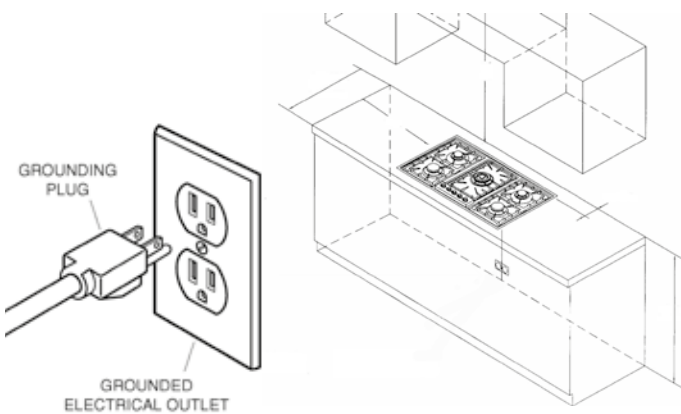

## WARNING

### Electrical Grounding Instructions

This appliance is equipped with a (three-prong) grounding plug for your protection against shock hazard and should be plugged directly into a properly grounded receptacle. Do not cut or remove the grounding prong from this plug.

All gas connections must be made according to national and local codes. This gas supply (service) line must be the same size or greater than the inlet line of the appliance. This range uses a 1/2" NPT inlet. Sealant on all pipe joints must be resistive to LP gas.

1. **Manual Shut-off Valve:** This installer-supplied valve must be installed in the gas service line ahead of the appliance in the gas stream and in a position where it can be reached quickly in the event of an emergency. The manual shut-off valve shall be installed properly in order to be accessible when appliance is installed in definitive position. In Massachusetts: A 'T' handle type manual gas valve must be installed in the gas supply line to this appliance. Refer to the illustration.

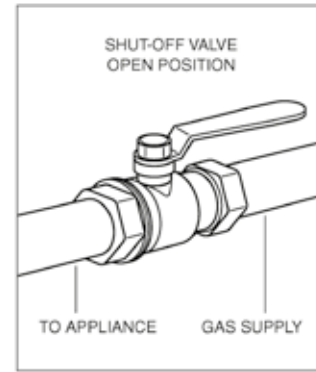

## 2. Pressure Regulator

- All heavy duty, commercial type cooking equipment must have a pressure regulator on the incoming service line for safe and efficient operation, since service pressure may fluctuate with local demand. The pressure regulator is supplied separately with the appliance; regulator has two female threads 1/2" NPT; it shall be installed properly in order to be accessible when appliance is installed in definitive position.
- This range can be used with Natural or LP/Propane gas. It is shipped from the factory adjusted for use with natural gas. The orifice hoods must be screwed snug when LP/Propane gas is used (see LP/Propane conversion).
- The appliance, its individual shut-off valve, and pressure regulator must be disconnected from the gas supply piping system during any pressure testing of that system at pressure is in excess of 1/2psig (3.45kPa).
- The appliance must be isolated from the gas supply piping system by closing its individual manual shut-off valve during any pressure testing of gas supply piping system at test pressures equal to or less than 1/2psig (3.45kPa).

## 3. Flexible Connections:

- If the unit is to be installed with flexible couplings and/or quick disconnect fittings, the installer must use an heavy duty, AGA design-certified commercial flexible connector of at least 1/2" (1.3cm) ID NPT (with suitable strain relieves) in compliance with ANSI Z21.41 and Z21.69 standards.
- In Massachusetts: The unit must be installed with a 36" (3-foot) long flexible gas connector.
- In Canada: CAN 1-6.10-88 metal connectors for gas appliances and CAN 1-6.9M79 quick disconnect device for use with gas fuel.

**CAUTION:** Leak testing of the appliance shall be conducted according to the manufacturer's instructions. Before placing the gas cooktop into operation, always check for leaks with a soapy water solution of other acceptable method. **DO NOT USE AN OPEN FLAME TO CHECK FOR LEAKS!**

# PERFORMANCE CHECKLIST

All burners are tested before leaving the factory. There are no adjustments for the burners if connected according to the information on the rating plate. Check each burner for proper operations. Flames should be blue in all settings. If service is required, contact your dealer for the name of their authorized service agency. Gas conversions and initial installation are not responsibility of the manufacturer.

**The installer should carry out the following performance checks. Refer to instructions below.**

1. Check surface burner ignition.
2. Check air shutter adjustment sharp blue flame, no yellow tipping, shooting or flame lifting.
3. Check low flame adjustment
4. Check for gas leaks (odors) at all gas connections.

## REQUIREMENTS

Room ventilation – Location and venting.

ATTENTION: A exhaust fan may be used with the appliance; in each case it shall be installed in conformity with the national standards in force.

ATTENTION: Exhaust hood operation may affect other vented appliances; in each case it shall be installed in conformity with the national standards in force.

## CONVERSION TO DIFFERENT TYPES OF GAS

Any conversion required must be performed by your dealer or a qualified licensed plumber or gas service company. Please provide the service person with this manual before work is started on the range. (Gas conversions are the responsibility of the dealer or end user.)

## WARNING

This conversion kit shall be installed by a qualified service agency in accordance with the manufacturer's instructions and all applicable codes and requirements of the authority having jurisdiction. If the information in these instructions is not followed exactly, a fire, explosion or production of carbon monoxide may result causing property damage, personal injury or loss of life. The qualified service agency is responsible for the proper installation of this kit. The installation is not proper and complete until the operation of the converted appliance is checked as specified in the manufacturer's instructions supplied with the kit.

## CAUTION

Before proceeding with the conversion, shut off the gas supply to the appliance prior to disconnecting the electrical power.

The appliance is supplied for use with a certain type of gas; if this has to be varied, you must change the burner injectors, adjust the air flow rate and the minimum gas flow.

Before carrying out these operations you must disconnect the electric power supply of the gas cooktop to avoid accidental contacts.

Before carrying out any maintenance work, disconnect the appliance from the gas and electric supply.

# ADAPTATION OF THE PRESSURE REGULATOR FOR USE WITH DIFFERENT TYPE OF GAS

The pressure regulator supplied with the appliance is a convertible type pressure regulator for use with Natural Gas at a nominal outlet pressure of 5" w.c. or LP gas at a nominal outlet pressure of 10" w.c. and it is pre-arranged from the factory to operate with one of these gas/pressure as indicated in the pre-arranging labels affixed on the appliance, package and Instruction booklet.

If Natural gas is converted to LP gas, also by-pass orifice has to be change.

The regulating crew of by-pass orifice must be fully screwed in.

To convert the regulator (Fig.1 and Fig.2) for use with the other gas different from which one it is pre-arranged it is enough perform the following operations:

- Unscrew by hand the upper metal stopper of the regulator.
- Unscrew by hand the white plastic piece screwed under the above mentioned metal stopper, afterward screw it again in opposite way under the metal stopper (for gas reference see the written "LP" and "NAT" with relative indicating arrows on the white piece).
- Screw again by hand the metal stopper in the original position on the regulator. Operating in this way the gas regulator is converted for use with the other gas/pressure

Fig. 1 Pressure regulator

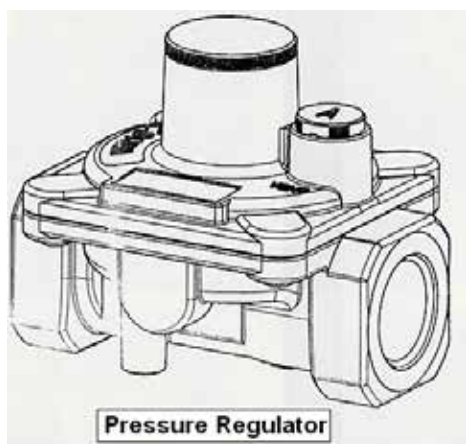
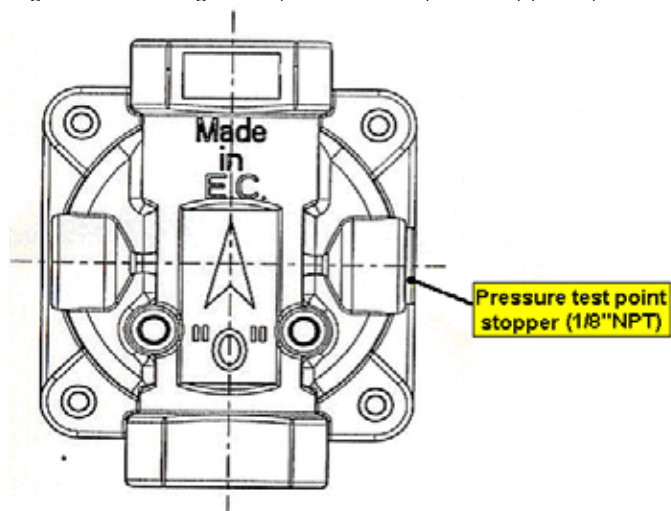

Fig. 2 Pressure regulator; pressure test-point stopper is pointed out



## See the table below for GAS supply pressure requirements

Note: Cooking with the probe cannot be used in the "DEFROST," "QUICK START," "PIZZA," and "ECO" functions.

With the oven in stand-by, insert the meat probe into the appropriate connection socket, which is usually located on the left wall of the oven. The display will show "MEAT" for 2 seconds, and the probe symbol will start flashing. Then, the default probe temperature value (75°C) will appear on the display. Turn and then press the control knob to select the desired end cooking temperature between the two limits of 40°C and 100°C (internal temperature of the food). After 4 seconds from the last setting, the chosen temperature will be stored, and the probe symbol will remain lit. Turn on the oven, select the cooking function, and set the desired temperature using the appropriate knobs. The temperature read by the probe will then appear on the display. When the programmed probe temperature is reached, the oven will turn off, an audible signal will sound, "End" will flash on the display, and the oven will switch to "cooking finished" mode.

During cooking, it is always possible to modify the probe temperature by pressing the knob 3 times and then turning the control knob.

Note: If the probe is inserted into the connection socket during cooking, the oven will turn off, and "Off" will appear on the display.

If the probe is removed from the socket during cooking, the oven will turn off, and "Off" will appear on the display.

Gas Supply		Specifications	
Gaz Type	Pression d'admission (WC)	Min. Gas Supply Pressure (WC)	Max. Input Pressure
Natural	5	6	1/2 psi
PL	10	11	1/2 psi

liance must be disconnected from the GAS supply piëping system during any pressure testing of that system.

# CHANGING THE INJECTORS AND ADJUSTING THE AIR

TABLE 2

Burner	Gas	Input rate [Btu/h]	Orifice size (1/100) mm	Simmer rate [Btu/h]	By-pass orifice size (1/100) mm (* only for UHCP36..., UHCP48..)
SR	NATURAL (A)	7000	120	1400	Adj
R	NATURAL (A)	10500	145	2000	Adj
DUAL	NATURAL (A)	18000	75+190	6300	Adj
DUAL	NATURAL (A)	22000	75+210	6300	Adj
DUAL (only AUX)	NATURAL (A)	2800	75	900	Adj
SR	LP (E)	7000	78	1400	30 / 32*
R	LP (E)	10500	95	2000	38 / 40*
DUAL	LP (E)	18000	52+120	6800	24+65 / 27*+60*
DUAL	LP (E)	22000	52+125	7300	24+65 / 27*+60*
DUAL (only AUX)	NATURAL (A)	2800	52	900	24 / 27*

The kit for the gas conversion of the burners is relevant to the model of the appliance indicated on the label sti-king to the first page of this booklet.

The kit contains the number and type of orifices necessary for the conversion and a label to stick onto the old one to show the new setting ( see table 2)

The appliance is pre-adjusted in factory for the gas indicated on the label put on the gas inlet pipe. For the conversion to another gas refer to table 3.

The positions, types of burner and relevant orifices for the models included in this booklet are depicted in table 3.





The only operation to perform after conversion to a gas different from that shown on the rating platelabel is the adjustment of the minimum gas flow. After conversion remember to put the new gas indication label ( supplied in the conversion kit) as close as possible to the existing rating plate, then check the regular ignition of the burners.

If the appliance is installed at an altitude exceeding 2,000 ft, a new set of orifices can be requested from the supplier or an authorised service parts distributor.

NOTE: Due to the lower atmospheric pressure at higher altitudes, foods tend to take longer to cook. Therefore, recipe adjustments should be made in some cases. In general, no recipe adjustment is necessary for yeast-risen baked goods, although allowing the dough or batter to rise twice before the final pan rising develops a better flavor. Try making the adjustments below for successful recipes. Take note of the changes that work best and mark your recipes accordingly. You may also consult a cookbook on highaltitude cooking for specific recommendations.

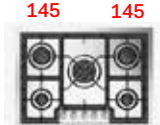
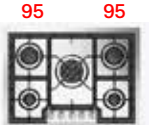
# CONVERSION KIT INSTALLATION INSTRUCTIONS

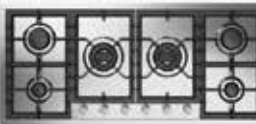
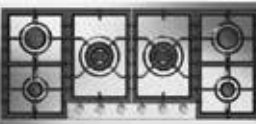
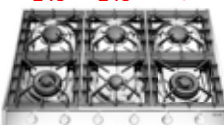
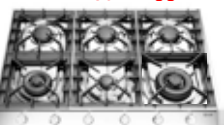
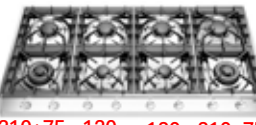
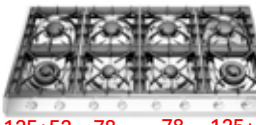
## CONVERSION KIT INSTALLATION INSTRUCTIONS

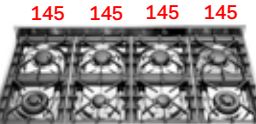
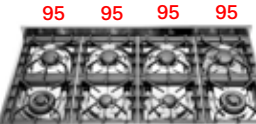
CODE	NATURAL GAS	PROPANE GAS
UHC(P/PT)75 UHC(P/PT)75N	 <p>145 145 120 190+75 120</p>	 <p>95 95 78 120+52 78</p>
UHC(P/PT)95 - UHC(P/PT)95(F/FF) UHC(P/PT)95N - UHC(P/PT)95(F/FF)N UHC(PM/PMT)95 - UHC(PM/PMT)95(F/FF)	 <p>145 145 120 190+75 120</p>	 <p>95 95 78 120+52 78</p>
UHC(P/PT)125 - UHC(P/PT)125(F/FF) UHC(P/PT)125N - UHC(P/PT)125(F/FF)N UHC(PM/PMT)125 - UHC(PM/PMT)125(F/FF)	 <p>145 190+75 145 120 190+75 120</p>	 <p>95 120+52 95 78 120+52 78</p>
UHCP965(6/F) UHCP965(6/F)N	 <p>145 145 145 210+75 120 210+75</p>	 <p>95 95 95 125+52 78 125+52</p>
UHCP1265(8/F) UHCP1265(8/F)N	 <p>145 145 145 145 210+75 120 120 210+75</p>	 <p>95 95 95 95 125+52 78 78 125+52</p>
UHCP36(6/F) UHCP36(6/F)N	 <p>145 145 145 210+75 120 210+75</p>	 <p>95 95 95 125+52 78 125+52</p>
UHCP48(8/F) UHCP48(8/F)N	 <p>145 145 145 145 210+75 120 120 210+75</p>	 <p>95 95 95 95 125+52 78 78 125+52</p>

 **WARNING:** save the orifices removed from the appliance for future use

**NOTE:** To go back to the original set replace old orifices as shown

**WARNING:** This conversion kit shall be installed by a qualified service agency in accordance with the manufacturer's instructions and all applicable codes and requirements of the authority having jurisdiction. If the information in these instructions is not followed exactly, a fire, explosion or production of carbon monoxide may result causing property damage, personal injury or loss of life. The qualified service agency is responsible for the proper installation of this kit. The installation is not proper and complete until the operation of the converted appliance is checked as specified in the manufacturer's instructions supplied with the kit.

# BURNERS OF THE HOB

## Replacement of the injectors

Procedure: SR - R

1. Remove the grill and the burners from the hob.
2. Burners SR - R:

unscrew injectors "U" using a 7 mm spanner and replace them with those for the new gas. Save the orifices removed from the appliance for future use.

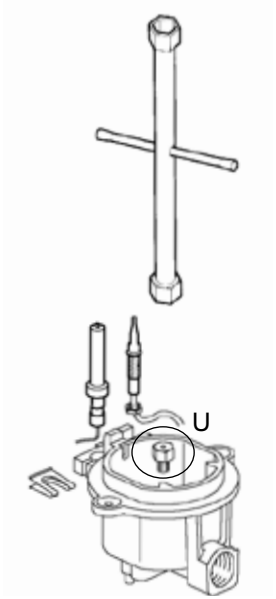

## Adjusting the minimum gas flow

When installing the gas cooktop you must check that the minimum gas flow of the burners is correctly regulated. If the type of gas is changed it is indispensable to adjust the minimum flow. The regulating procedure is as follows.

A) Burners on the hob.

1. Light one burner at a time and turn the flame up to maximum.
2. Remove the knob of the corresponding gas tap and insert screwdriver in the screw as showed in figure.
3. Turn the tap to minimum position.
4. Unscrew, turning to the left, to increase the flame, or screw to the right to decrease it.
5. If a liquid gas is used (Butane - Propane), the regulating screw must be fully screwed in.

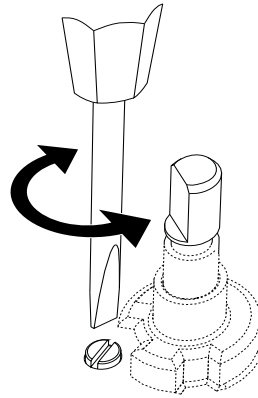

## Procedure: DUAL

1. Dual burners: unscrew the 2 screws "P" and remove cover "C" fig.2.
2. unscrew injectors "U" using a 7 mm spanner and replace them with those for the new gas. Save the orifices removed from the appliance for future use.

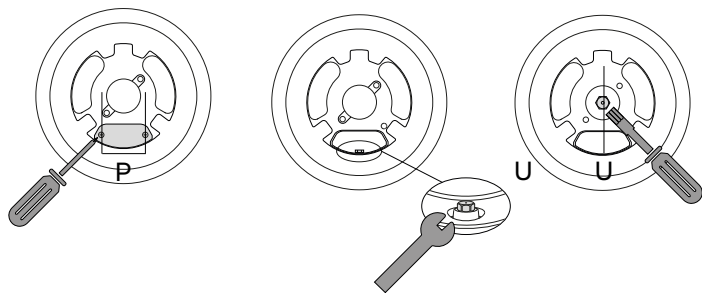

# INSTRUCTIONS FOR USE

## Burners

Position the flame divider "b" correctly. To do this, align the 4 teeth "c" of the flame divider with the recess "d" of the aluminium Cup "a".

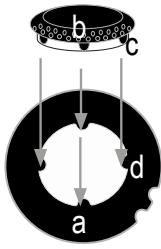

### Service and maintenance instructions

Replacement Parts.

Authorized replacement parts may be used in performing service on the appliance. Replacement parts are available from factory authorized part distributors.

**Service and maintenance only to be carried out by an authorised person.**

To replace parts such as burners, valves and electric components, the hotplate must be removed from the bench top by releasing the attachment hooks, loosening the attachment screws of each burner, unscrewing the hotplate attachment nuts which are visible at the bottom of the surface, removing the hotplate top and finally replacing the defective parts. Note 1: if the valves must be replaced, first disassemble the ignition switches wires. It is recommended to replace the valve gaskets each time the valve is replaced.

Note 2: if the main gas pipe needs replacement, make sure it has the correct welded metal supports for assembly.

**WARNING:** after first installation of the appliance, after gas conversion kit installation or after any service intervention concerning main gas parts of the appliance, make the leak test using water with soap on the gas connections in order to verify the correct installation. Do not use fire for gas leak testing. The test is valid if there is no bubble or foam build-up during a period of one minute.

### Non working appliances

Before calling the After Sales Service, check that the appliance is connected or that the main switch is activated. After, call the After Sales Service. The faults must be checked by an experienced technician.

### Lighting the burners

The index above the knobs will help you to find the corresponding burner. Press the knob by turning it anti-clockwise and bring it to the ignition position; keep the knob pressed for about 5 seconds so that upon its release the flame remains alight. In case of unsuccessful ignition wait 5 minutes before relighting and repeat the operation. By turning the knob, the outer ring lights up red to indicate the GAS burner in operation

Symbol	Function	Knob
	index	
	off	
	max	
	min	

### Burners "DUAL"

Identify the knob with the help of the index near the knobs. Press and turn the knob to the symbol (maximum) for 5 seconds. Once the burner is on, by turning the knob

counterclockwise it gets to its first block that corresponds to the middle one.

By applying a bit of force, the first block is exceeded and the outer ring goes out leaving only the little central burner turned on called AUXILIARY. To adjust the auxiliary burner on minimum, rotate the knob counterclockwise until it stops. At this point, to turn the burner back on, rotate the knob clockwise up to the desired value.

### DUAL

Symbol	Function	Knob
	off	
	max	
	min	

### AUX

Symbol	Function	Knob
	off	
	max	
	min	

# INSTRUCTIONS FOR USE

## Recommended pans according to burner size:

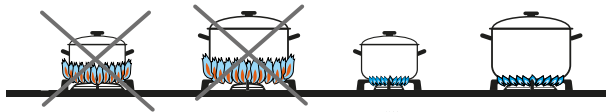

Burners	ID	Diameter Ø (cm)
Medium	SR	12 ÷ 20
Large	R	20 ÷ 24
Dual - Ring	DUAL	12 ÷ 30

## Positioning of the burners

⚠ Always check that the burners are properly positioned, with a uniform flame that is not noisy.

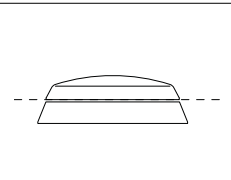
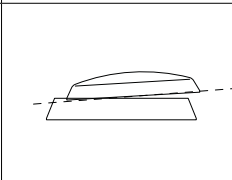
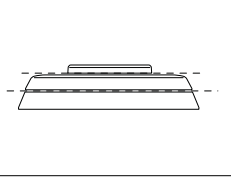
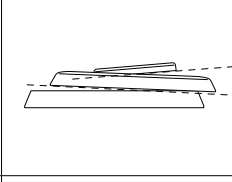
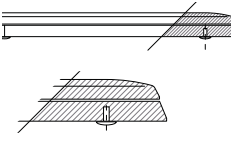
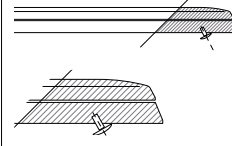
Burners	Right	Wrong
Medium Large		
Dual Ring		
Fish burner Always check that the screws below the burner are fixed		

## Cleaning and maintenance

ATTENTION: burners with nanotechnological coating

Some cleaning and washing methods are recommended in order to preserve the quality of the coating.

Allow the product to cool down at room temperature before cleaning it. It is recommended not to dip it in cold water when it is still hot.

Wash with warm water and a minimum of neutral detergent. Rub with a cloth, better if in natural cellulose, or non-abrasive sponge.

Do not use dust, iron wool, cloths and abrasive sponges.

Do not let food be charred on the burner. In case stains/colorations may appear on the surface. These traces do not alter the functionality of the product, and in some cases can be eliminated with this procedure: immerse the product in hot water, with detergent, wipe gently with a cloth, better if in natural cellulose; in any case, do not use abrasive cloths or sponges. For the most resistant stains, it is advisable to warm white vinegar and rub as indicated above.

Avoid leaving the burners in contact with food for a long time, especially if acidic, such as tomato sauce.

Avoid contact with metal objects; if really needed, use wooden or plastic objects.

Avoid washing in the dishwasher, a part of the product is not coated and would get irreparably damaged.

In order for the DUAL burner to function properly, it is important to keep the ignition channel clean, as shown in the figure below.

# GAS COOKTOP INSTALLATION

## Functions

Remove the cooktop, gas pressure regulator, burner grates and burner caps from the shipping package. Lower the cooktop into the countertop cut-out opening. Center the cooktop in the opening and check that the front edge of cooktop is parallel to the front edge of the countertop. Check that all required clearances are met. Remove the cooktop from the counter-top opening.

**IMPORTANT NOTE:** When repositioning the cooktop in the countertop opening, lift the entire cooktop up from the opening to prevent scratching the countertop. Apply the foam strip, included in the hardware package, to the under side of the cooktop frame. Refer to the illustration below.

Reinsert the cooktop into the countertop opening. Lift the entire cooktop to make adjustments. Attach the brackets to the bottom of the unit. Insert the clamping screws into the brackets. Use a screw-driver to tighten the clamping screws against the underside of the countertop. Refer to the illustration below. Do not overtighten screws.

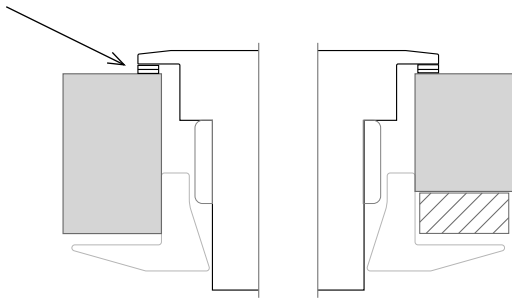

**IMPORTANT NOTE:** Do not seal the cooktop to the countertop. It must be removed if service is necessary.

**GAS PRESSURE REGULATOR** Install the gas pressure regulator with the arrow on the regulator pointing up toward the unit and in a position where you can reach the access cap.

**IMPORTANT NOTE:** All connections must be wrench-tight-ened. Do not make connections to the regulator too tight, as this may crack the regulator and cause a gas leak. Do not allow the regulator to turn on the pipe when tightening fittings.

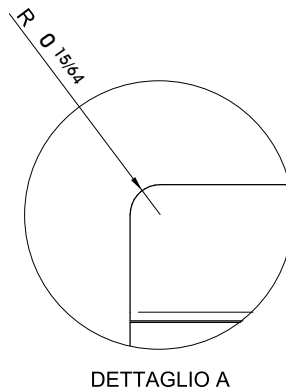
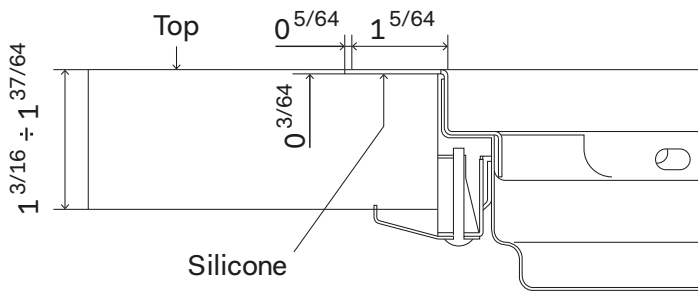
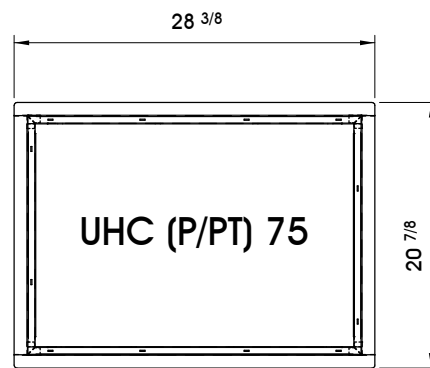
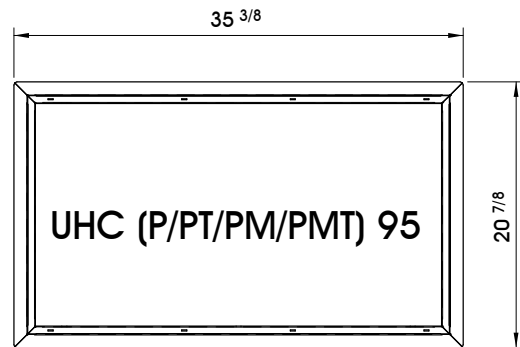
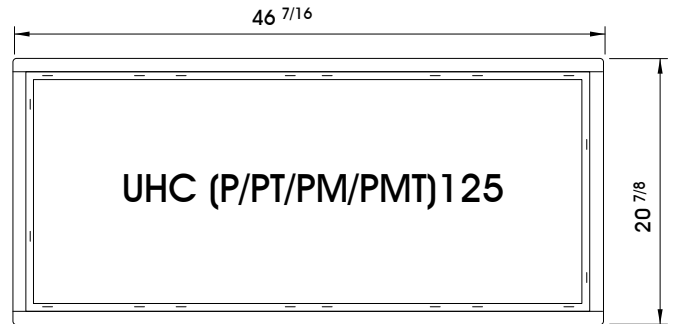

# GAS SUPPLY CONNECTION

Assemble the flexible metal connector from the gas supply pipe to the gas pressure regulator. You will need to determine the fittings required, depending on the size of your gas supply line, flexible metal connector and shut-off valve. Refer to the illustration below. Use a pipe joint compound made for use with natural and LP gas. If a flexible metal connector is used, be sure the tubing is not kinked.

Open the shut-off valve in the gas supply line. Wait a few minutes for the gas to move through the line.

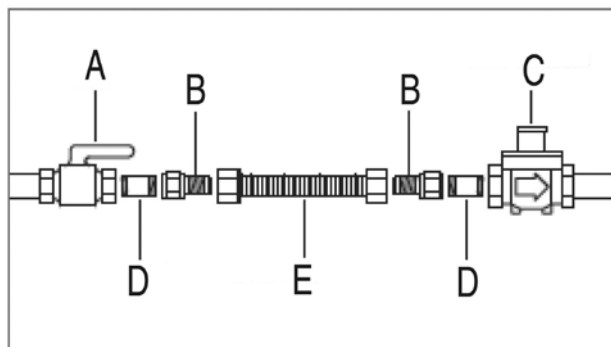

A	Shut-off valve
B	Adapter
C	Gas pressure regulator
D	Nipple
E	Flexible metal connector

## Gas leak testing

Use a brush and liquid detergent to test all gas connections for leaks. Bubbles around connections will indicate a leak. If a leak appears, shut off the gas supply and adjust connections. Then check connections again. Clean the detergent solution from the cooktop.



### WARNING

Never test for a gas leak with a match or other flame

# INSTALLATION

UHC(P/PT)75., UHC(P/PT/PM/PMT)95., UHC(P/PT/PM/PMT)125.,

## Proximity to Side Cabinet Installation

The cooktop may be installed directly to existing base cabinets. The cooktop CANNOT be installed directly adjacent to sidewalls, tall cabinets, tall appliances, or other side vertical surfaces above 36" (91.4 cm) high. There must be a minimum of 8" (20.3 cm) side clearance from the cut-out to such combustible surfaces above the 36" (91.4 cm) counter height. Within the 8" (20.3 cm) side clearance to combustible vertical surfaces above 36" (91.4 cm), the maximum wall cabinet depth must be 13" (33.0 cm) and wall cabinets within this 8" (20.3 cm) side clearance must be 18" (45.7 cm) above the 36" (91.4 cm) high countertop. Wall cabinet above the cooktop must be a minimum of 36" (91.4 cm) above the countertop. This minimum height requirement does not apply if a rangehood is installed over the cooking surface.

### Minimum Clearances from Adjacent

#### Combustible Construction

Above countertop 36" (91.4 cm) minimum

Side 8" (20.3 cm)

Rear 3" (7.62 cm) min.

Wall cabinets no deeper than 13" (33.0 cm)

Must be minimum 18" (45.7 cm) above countertop

Wall cabinets directly above the product must be minimum 36" (91.4 cm) above the countertop

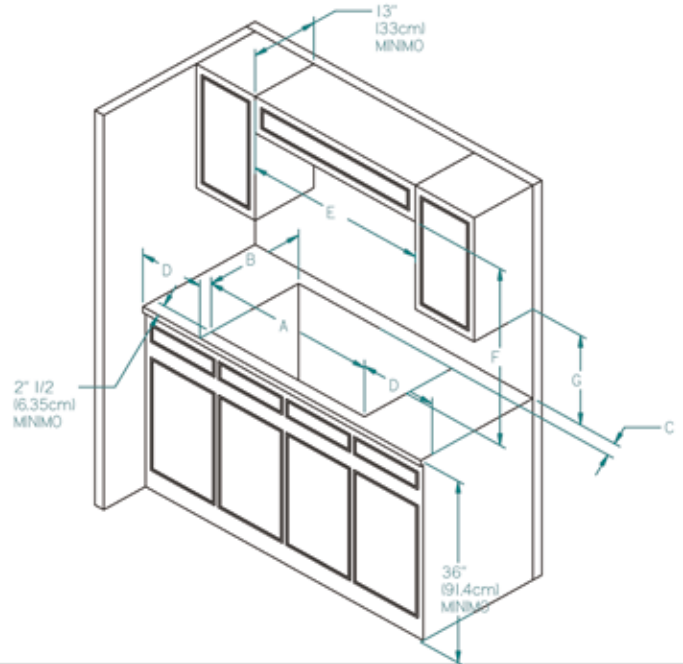

	UHC (P/PT)75...	UHC (P/PT/PM/PMT)95...	UHC (P/PT/PM/PMT)125...
A	26 29/64' (67.2 cm)	33 55/64' (86.0 cm)	44 7/8' (114.0 cm)
B	19 19/64' (49 cm)	19 19/64' (49 cm)	19 19/64' (49 cm)
C	MIN. 3' (7.62 cm)	MIN. 3' (7.62 cm)	MIN. 3' (7.62 cm)
D	MIN. 8' (20.3 cm)	MIN. 8' (20.3 cm)	MIN. 8' (20.3 cm)
E	MIN. 28 1/2 (72.4 cm)	MIN. 35 1/2 (90.2 cm)	MIN. 46 1/2 (118.1 cm)
F	MIN. 36' (91.4 cm)	MIN. 36' (91.4 cm)	MIN. 36' (91.4 cm)
G	MIN. 18' (47.7 cm)	MIN. 18' (47.7 cm)	MIN. 18' (47.7 cm)

# INSTALLATION

UHCP965.., UHCP1265.., UHCP36..., UHCP48..,

## Proximity to Side Cabinet Installation

The cooktop may be installed directly to existing base cabinets. The cooktop CANNOT be installed directly adjacent to sidewalls, tall cabinets, tall appliances, or other side vertical surfaces above 36" (91.4 cm) high. There must be a minimum of 8" (20.3 cm) side clearance from the cooktop to such combustible surfaces above the 36" (91.4 cm) counter height.

Within the 8" (20.3 cm) side clearance to combustible vertical surfaces above 36" (91.4 cm), the maximum wall cabinet depth must be 13" (33.0 cm) and wall cabinets within this 8" (20.3 cm) side clearance must be 18" (45.7 cm) above the 36" (91.4 cm) high countertop.

The maximum wall cabinet depth must be 13" (33.0 cm) and wall cabinets within this 8" (20.3 cm) side clearance must be 18" (45.7 cm) above the 36" (91.4 cm) high countertop

Wall cabinet above the cooktop must be a minimum of 36" (91.4 cm) above the burner grates. This minimum height requirement does not apply if a rangehood is installed over the cooking surface.

Minimum Clearances from Adjacent

Combustible Construction

Above countertop 36" (91.4 cm) minimum

Side 8" (20.3 cm)

Wall cabinets no deeper than 13" (33.0 cm)

Must be minimum 18" (45.7 cm) above countertop

Wall cabinets directly above the product must be minimum 36" (91.4 cm) above the burner grates

A hole of 1" 31/32 (5 cm x 5 cm) must be done on the top for power cable and gas conduit as shown in picture

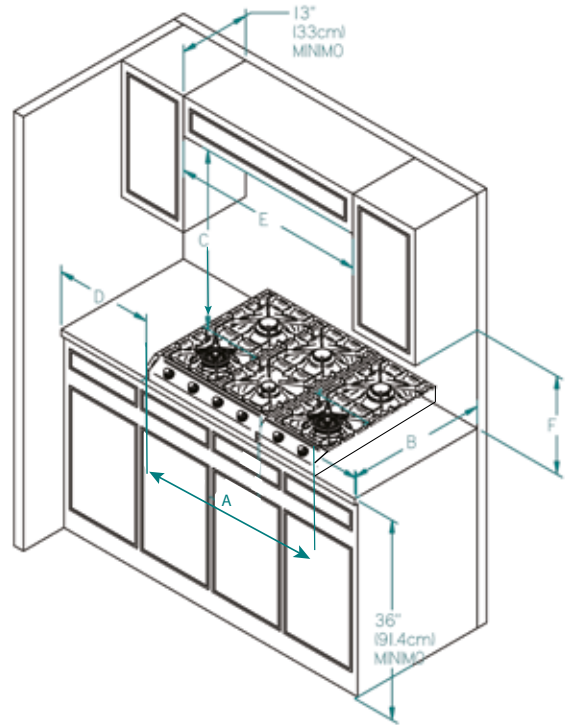

	UHC P 965.. UHC P 36...	UHC P 1265.. UHC P 48...
<b>A</b>	35 7/8" (91.1 cm)	47 7/8" (121.6 cm)
<b>B</b>	25 19/32" (65 cm)	25 19/32" (65 cm)
<b>C</b>	MIN. 36" (91.4 cm)	MIN. 36" (91.4 cm)
<b>D</b>	MIN. 8" (20.3 cm)	MIN. 8" (20.3 cm)
<b>E</b>	MIN. 36" (91.4 cm)	MIN. 48" (121.9 cm)
<b>F</b>	MIN. 18" (47.7 cm)	MIN. 18" (47.7 cm)

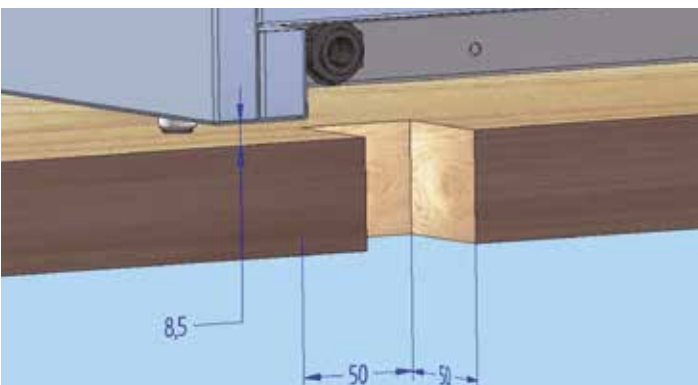
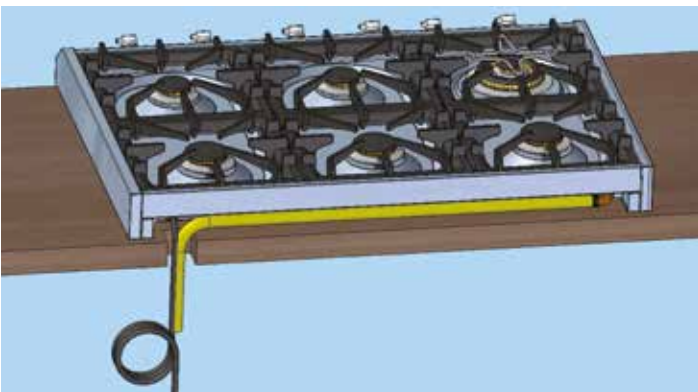

# WIRING DIAGRAM

## LED Display L3

KEYS	
33	White
45	Green
00	Black
SP	Ignition electrode
MA	Ignition microswitch
AA	Ignition transformer
M	Terminal board
F	Phase
N	Neutral

### 8 BURNERS

UHC P 1265... UHC P 48...

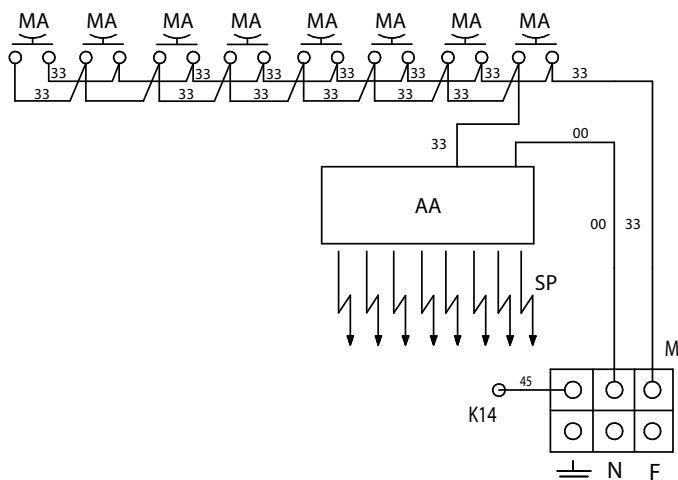

### 5 BURNERS

UHC (P/PT) 75... UHC (P/PT/PM/PMT) 95...

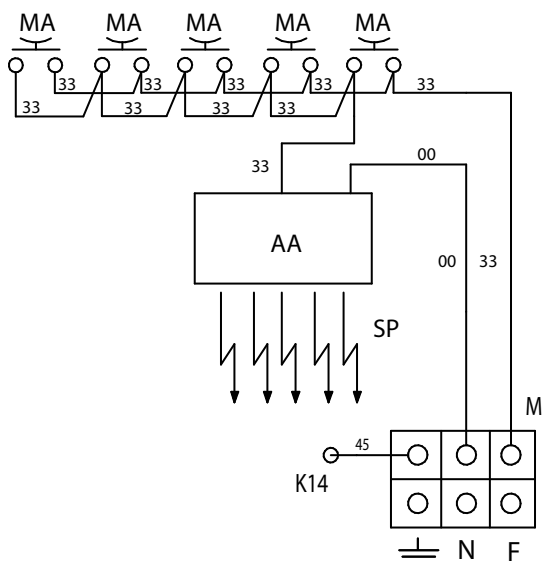



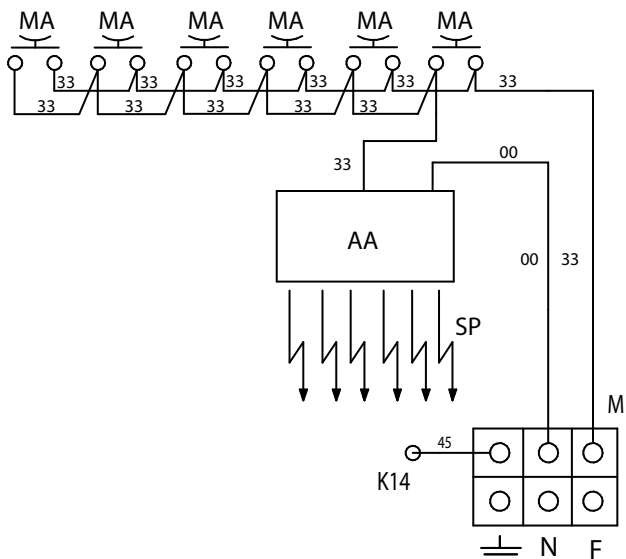

### 6 BURNERS

UHC P 36... UHC (P/PT/PM/PMT) 125...

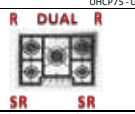
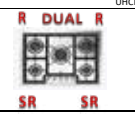
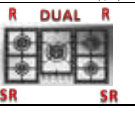
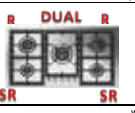
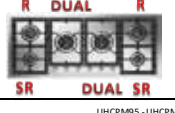
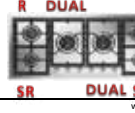
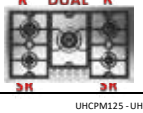
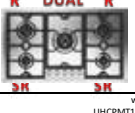
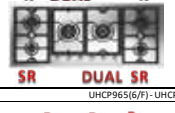
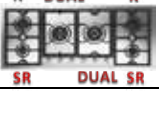
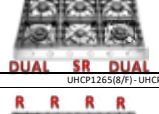
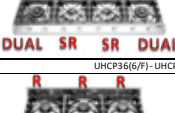
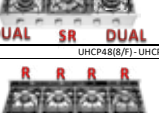

# ELECTRICAL AND GAS POWER TABLE

MODEL	BURNERS				COMPLETE APPLIANCE GAS RATING [Btu/h]	COMPLETE APPLIANCE ELECTRIC RATED INPUT [W]		
	SR 7000 Btu	R 10500 Btu	DUAL 18000 Btu	DUAL 22000 Btu				
BUILT-IN GAS COOKTOP UHC(P/PT)75 UHC(P/PT)75N	2	2	1		53000	1	UHCP75 - UHCP75N 	with Rat frame UHCP75 - UHCP75N 
BUILT-IN GAS COOKTOP UHC(P/PT)95 - UHC(P/PT)95(F/FF) UHC(P/PT)95N - UHC(P/PT)95(F/FF)N	2	2	1		53000	1	UHCP95 - UHCP95(F/FF) - UHCP95N - UHCP95(F/FF)N 	with Rat frame UHCP95 - UHCP95(F/FF) - UHCP95N - UHCP95(F/FF)N 
BUILT-IN GAS COOKTOP UHC(P/PT)125 - UHC(P/PT)125(F/FF) UHC(P/PT)125N - UHC(P/PT)125(F/FF)N	2	2	2		71000	1	UHCP125 - UHCP125(F/FF) - UHCP125N - UHCP125(F/FF)N 	with Rat frame UHCP125 - UHCP125(F/FF) - UHCP125N - UHCP125(F/FF)N 
BUILT-IN GAS COOKTOP UHC(P/PT)95 - UHC(P/PT)95(F/FF)	2	2	1		53000	1	UHCPM95 - UHCPM95(F/FF) 	with Rat frame UHCPM95 - UHCPM95(F/FF) 
BUILT-IN GAS COOKTOP UHC(P/PT)125 - UHC(P/PT)125(F/FF)	2	2	2		71000	1	UHCPM125 - UHCPM125(F/FF) 	with Rat frame UHCPM125 - UHCPM125(F/FF) 
FREESTANDING GAS HOB UHCP965(6/F) UHCP965(6/F)N	1	3		2	82500	1	UHCP965(6/F) - UHCP965(6/F)N 	
FREESTANDING GAS HOB UHCP1265(8/F) UHCP1265(8/F)N	2	4		2	100000	1	UHCP1265(8/F) - UHCP1265(8/F)N 	
FREESTANDING GAS HOB UHCP36(6/F) UHCP36(6/F)N	1	3		2	82500	1	UHCP36(6/F) - UHCP36(6/F)N 	
FREESTANDING GAS HOB UHCP48(8/F) UHCP48(8/F)N	2	4		2	100000	1	UHCP48(8/F) - UHCP48(8/F)N 	
FREESTANDING INDUCTION HOB UHCP1366 UHCP1366N						11520		
FREESTANDING INDUCTION HOB UHCP1486 UHCP1486N						11520		

## Injectors for a device installed at an altitude above 2000 ft

Burner	Gas	Orifice size [1/100] mm
SR	NATURAL (A)	117
R	NATURAL (A)	141
DUAL (18000 Btu/h)	NATURAL (A)	74+185
DUAL (22000 Btu/h)	NATURAL (A)	74+200
SR	PROPANE (E)	75
R	PROPANE (E)	92
DUAL (18000 Btu/h)	PROPANE (E)	50+117
DUAL (22000 Btu/h)	PROPANE (E)	50+120



Live,  
Cook,  
Love.

**ilve.com**

ILVE S.p.A Via Antoniana, 100 – 35011 – Campodarsego (PD) Italy  
T. +39 049 9200990 / Email: mail@ilve.com

cod. EI33960760000EN 06/2025