

TK4 系留供电系统

2026.1 V1.0

用户手册 User Manual

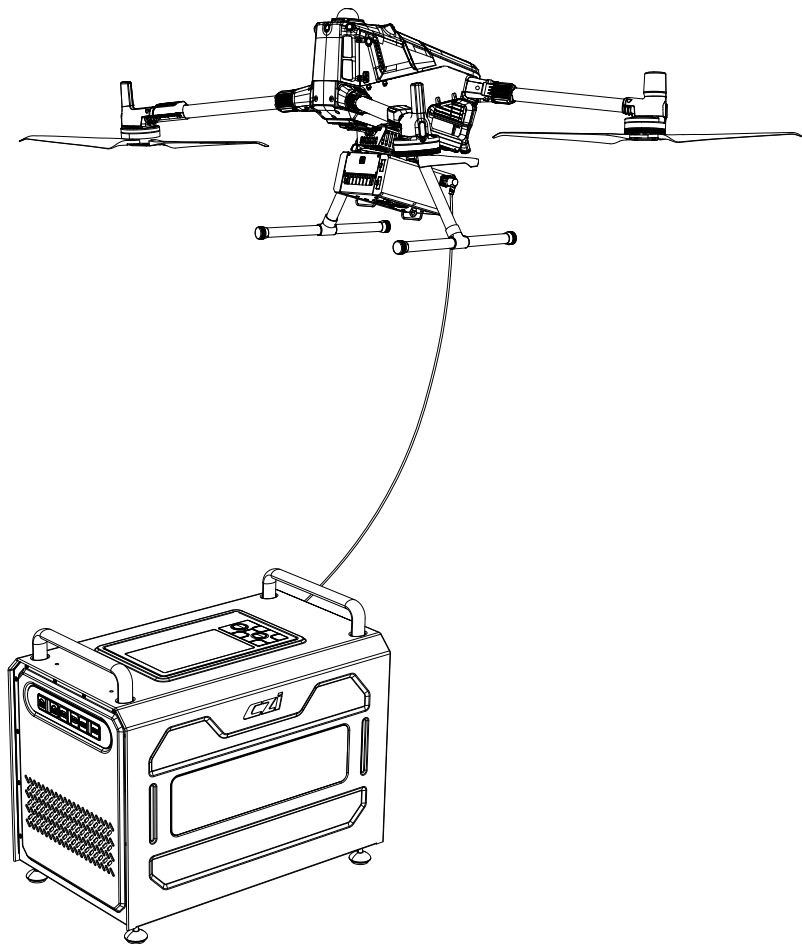

目录

一、免责声明与警告	01
二、TK4供电系统介绍	02
三、设备参数.....	03
四、TK4供电系统安装和使用教程	04
五、产品使用介绍.....	12
六、使用后拆卸及回收TK4_地面端的拆卸:(地面端拆卸之前确保关闭高压)	19
七、附录1:经测试可兼容的发电设备示例	22
八、产品官网链接.....	23

Contents

1.Disclaimers and Warnings	24
2.Overview.....	25
3.Specifications.....	26
4.Installation and Operation Guide.....	28
5.Product Operation Instructions	36
6.Post-Use Procedure.....	43
7.Appendix 1: Examples of Tested Compatible Generators	46
8.Official Website Links	47

电子文档阅读/下载

注意: 本文档内容会持续更新优化, 将通过电子档形式更新, 一切内容以最新版说明书为依据! 用户可扫描二维码阅读或下载最新版《TK4系留供电系统使用说明》



一、免责声明与警告

感谢您购买成至智能产品。本文所提及的内容关系到您的安全以及合法权益与责任。使用本产品之前, 请仔细阅读本文以确保已对产品进行正确的设置。不遵循和不按照本文的说明与警告来操作可能会给您和周围的人带来伤害, 损坏本产品或者其他周围的物品。本文档及所有相关的文档最终解释权归成至智能所有。如有更新, 恕不另行通知。请访问广州成至智能机器科技有限公司官方网站以获取最新的产品信息。

⚠️ 安全注意事项

- ①使用前需要仔细阅读说明书, 确保TK4线缆被正确连接到无人机上。为防止旋转的桨叶打到TK4线缆, 需要将系留线缆上的挂钩正确地固定在天空端上的挂环上。
- ②在使用无人机时, 当地面端线缆出现余线5米的标识时, 请勿继续增加飞行高度; 请勿以手动方式拉扯线缆; 如未按本提示操作, 导致线缆绷断、设备坠毁、人身伤害或第三方损失, 相关责任由操作者承担。
- ③请确保市电输入交流电的范围在176-264V内, 本设备建议使用市电, 市电条件无法满足时, 建议选购逆变器配套使用。避免供电不良造成的设备故障。
- ④如没有市电的条件下, 设备只支持变频发电机作为外部发电设备。为避免使用过程中的功率变化过大, 导致的过载或欠载问题, 请勿使用定频发电机为设备发电。
经本公司技术部门严格测试, 确认以下型号发电机与本产品完全兼容, 性能稳定可靠。推荐型号: 神驰 SC8000iF变频发电机 (详情请看附录1)。

⚠️ 推荐兼容的发电机设备仅供参考, TK4系留供电系统 不对第三方设备的质量、安全性及后续固件更新承担责任。使用中如遇冲突, 建议优先联系对应设备制造商。

- ⑤为保证安全, 使用市电时, 需保证市电插头有输出4500W的能力。需保证市电的电压与电流稳定可靠。
- ⑥无人机飞行过程中, 不能断开市电的插头或者关闭设备。
- ⑦接电顺序: 连接电源线并接通市电后, 再打开紧急断电开关。
- ⑧使用 此设备 时, 无人机系留电池电量不要低于 60%。
- ⑨无人机起飞之前, 开启“紧急断电开关”, 否则无人机将无法起飞。
- ⑩为防止意外发生, 禁止在雨雪、霜雾、雷霆、冰雹、沙尘和强风等环境下使用。
- ⑪为防止意外发生, 任何时候都不可徒手触摸TK4线缆 (高压800V)。如必须带电接触TK4电缆, 请务必带好绝缘手套 (绝缘要求大于800V)。
- ⑫使用此设备时, 在高压塔附近及设备没有接市电时, 请务必接上外置接地钉。
- ⑬为确保设备散热效能, 须保持通风口及进风口畅通, 避免风道阻塞引发内部热量积累导致的过热风险。

二、TK4供电系统介绍

成至TK4地面系留供电系统是一款高性能系留解决方案，专为无人机长时间作业设计。它通过高效电力转换技术，将交流电转化为高压直流电，通过线缆传输至天空端，天空端通过降压技术将高压电力转化为无人机系留电池可直接使用的低压电力，为无人机动力系统和任务载荷提供充足电力供应。系统采用轻量化设计，配备高清显示屏和备用电源，适应严苛环境，具备优异的防护性能。适用于应急照明、安防监控等场景，确保无人机实现全天候不间断飞行作业，满足复杂任务需求。本产品适配有两款安装支架，（分别为A支架，B支架）请参阅4.3节“天空端安装”相关内容介绍。

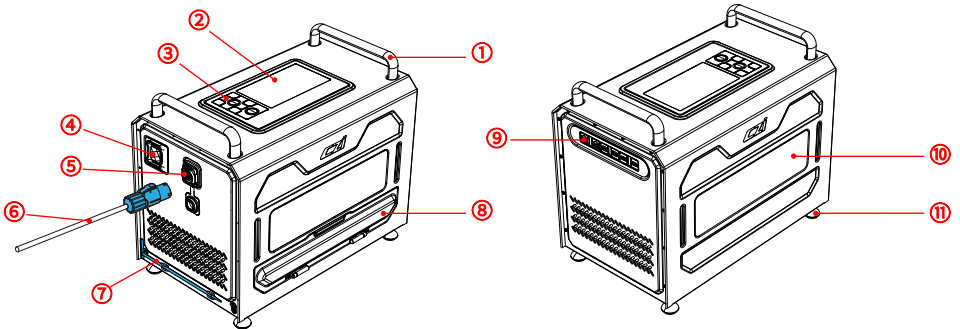
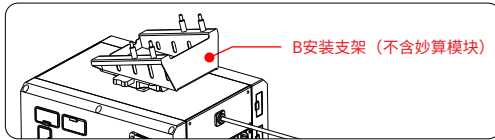
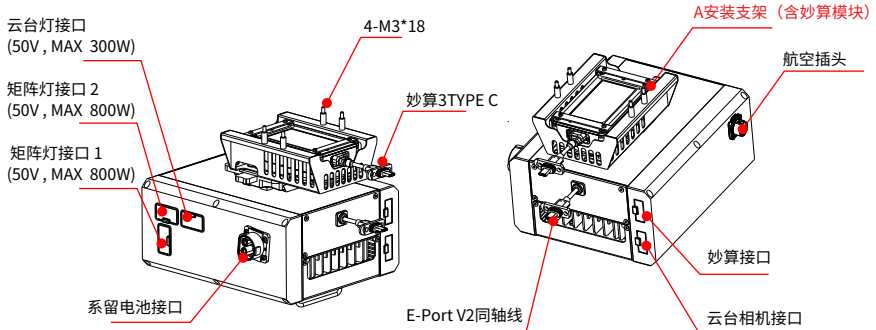

- ① 扶手
- ④ 紧急断电开关
- ⑦ 接地针
- ⑩ 观察视窗
- ② 显示屏
- ⑤ 电源输入口
- ⑧ 导线盖
- ⑪ 脚座
- ③ 按键板
- ⑥ 电源线
- ⑨ 外部设备连接

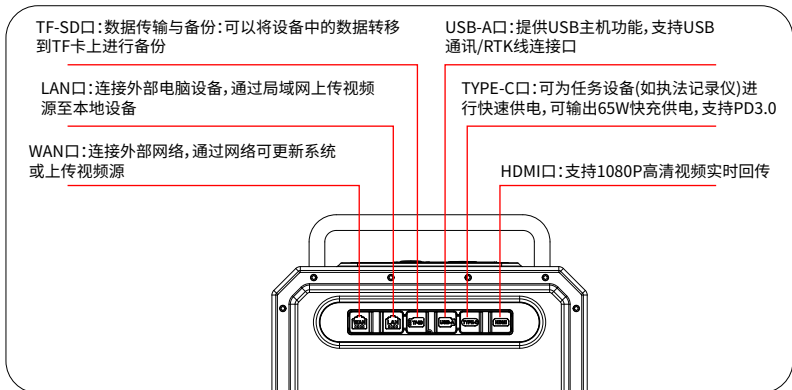

三、设备参数

TK4地面端规格参数	
尺寸	413*345*254mm(包含提手与脚架)
重量	≤13kg(含110m线缆)
输入电压	176-264VAC (50/60HZ)
输出电压	800v
输出功率	4.5kw
通信带宽	100M
TYPE-C快充接口	最大功率65W, 支持PD3.0/QC协议
屏幕尺寸	5.5寸
屏幕分辨率	1920*1080
备用电池	2600mAh, 22.2v
扬声器功率	10W
线缆长度	110m, 最高可选200m
线缆载流	5A
线缆耐压	DC 2000V
线缆重量	1.25kg/100m

线缆抗拉强度	>50kg
视频输出接口	HDMI、网口
使用海拔高度	4000m
工作环境温度	-20°C~50°C (无太阳辐射)
存储温度	-40°C~+70°C
TK4天空端规格参数	
尺寸	≤190*155*86mm (主体尺寸, 不含插头等突出部分)
重量	≤2kg(主体重量, 不含固定件)
输出功率	额定4000w
输出电压	50v
视频输入接口	Type-c
使用海拔高度	4000m
防护等级	IP55
工作环境温度	-20°C~50°C (无太阳辐射)
存储温度	-40°C~+70°C

四、TK4供电系统安装和使用教程

4.1 ML200-M400 矩阵灯的安装教程 (如购买时无灯, 请跳过4.1)

4.1.1 使用说明

1) 将照明灯主机的管夹开口对准支撑脚横杆 (如下图左), 再将主机向箭头方向压, 直到管夹将支撑脚横杆夹紧 (如下图右);

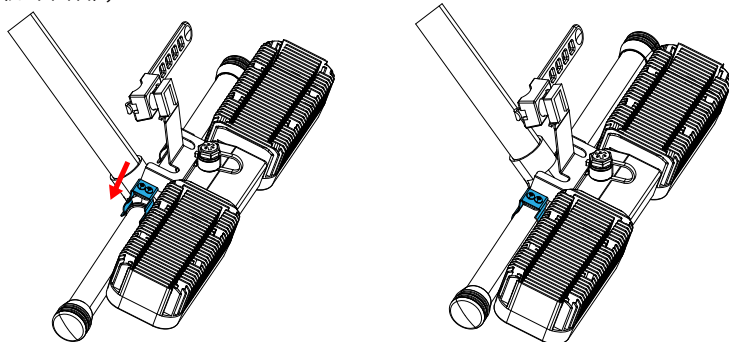

2) 将照明灯副机的管夹开口对准支撑脚横杆(如下图左),然后将副机向箭头方向压,直到管夹将支撑脚横杆夹紧(如下图右);

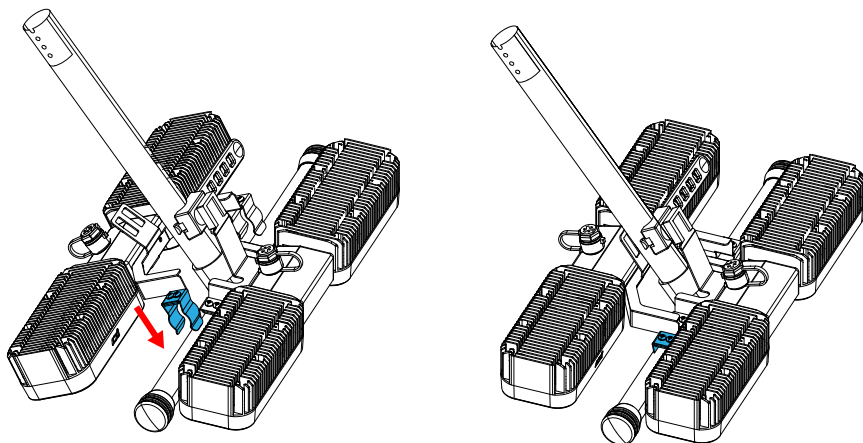

3) 将橡胶绑带穿过副机的连接臂,拉紧橡胶绑带并扣在绑带卡扣上,如下图;

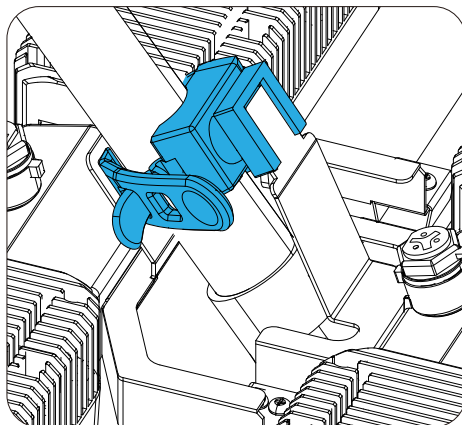

4) 拿出产品配置的电缆,逐一把端部的插头插入对应的插座内。

① 依次插上两个天空端插头;

② 拧开灯体上的插头防水盖再接线;

③ 依次插上灯体上的插头,并将插头上的螺母顺时针拧紧在插座上;

④将电缆按下图方式排布在两个支撑竖管上,用电缆自带的魔术贴将线缆固定,完成安装,如下图。

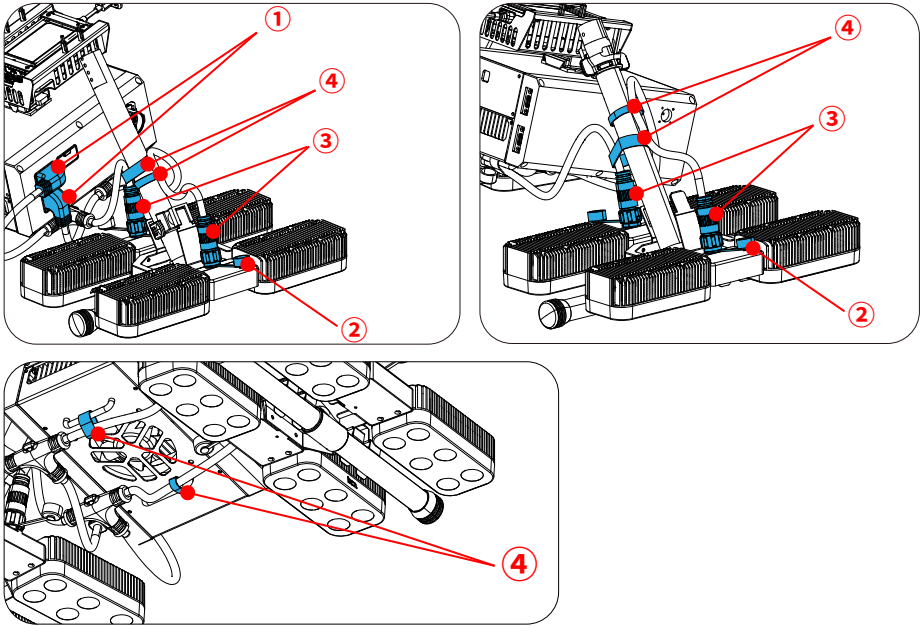

4.1.2 控制

上电后,系留地面端面可控制开关灯。

4.2 TK4 地面端的安装教程

4.2.1 接地针安装:从附件包取出接地钉,将接地钉手拧螺丝松开,拧紧接地线,将插入地下20CM左右。

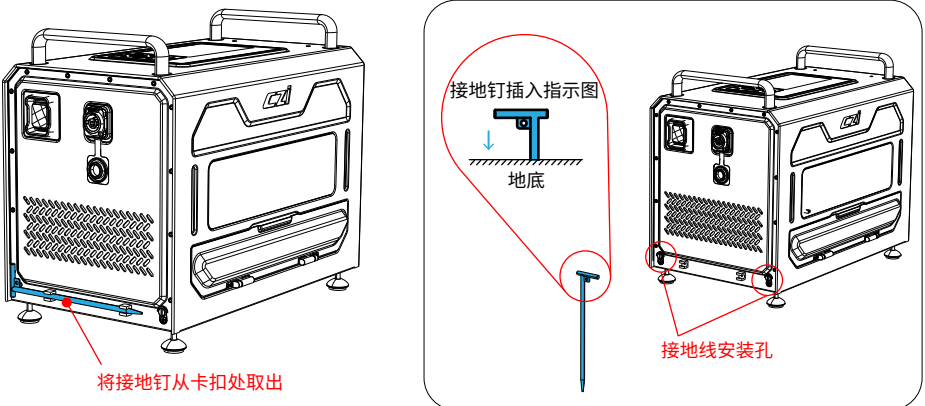

4.2.2 地面端电源连接: 打开电源座面盖, 图示1处的接线柱与图示2的电源输入口对准后, 将电源线插入, 顺时针旋转, 直到听到“咔”声, 表示已完成。

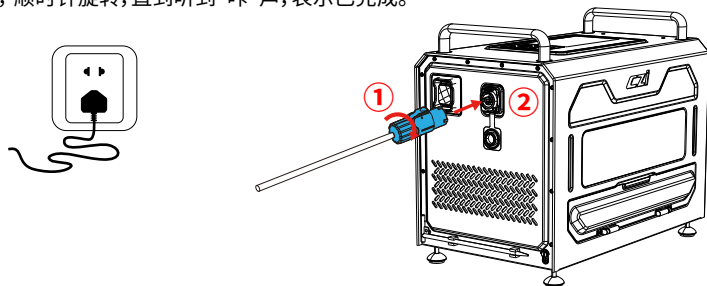

4.3 TK4 天空端的安装教程

4.3.1 取出TK4天空端的安装支架 (A支架已安装好妙算模块, B支架不含妙算模块), 对准大疆无人机 M400底部的4个孔位, 使用4个螺丝拧紧。

A安装支架: 推荐适配大疆单云台, 适配的负载有: 矩阵灯ML200-M400、云台灯GL310、云台相机C50N, 中继CR20, 大疆云台相机H30T, 大疆妙算3。

B安装支架: 推荐适配大疆双云台, 适配的负载有: 矩阵灯ML200-M400、云台灯GL310、云台相机C50N, 中继CR20, 大疆云台相机H30T。

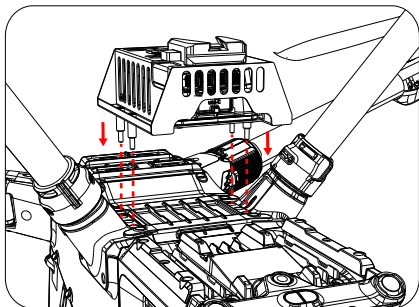

A安装支架 (含妙算模块) 示意图

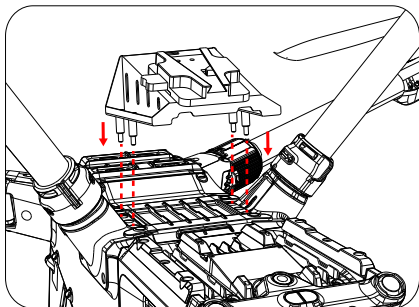

B安装支架 (不含妙算模块) 示意图

4.3.2 将TK4本体取出, 将上面的Y型滑块对准支架底部的Y型快拆座, 推进去直到听到“咔”声, 表示已完成。

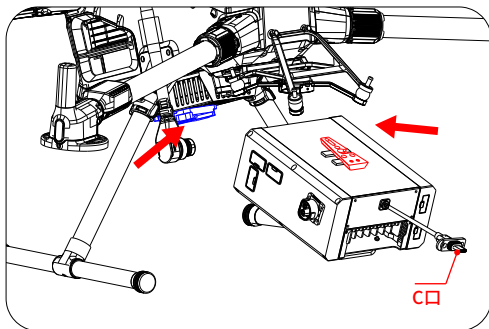

4.3.3 分别将无人机系留电池上的电源插头(红色)插到天空端的电源插座上(蓝色),然后天空端的C口线安装在无人机的“E4”上,并用螺丝刀将C口旁的两颗螺丝锁住。

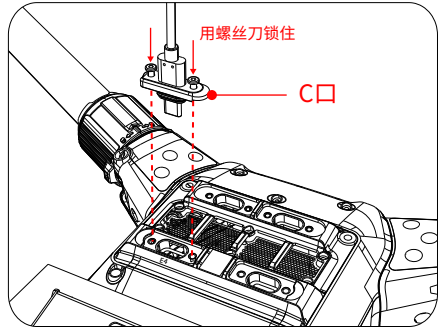
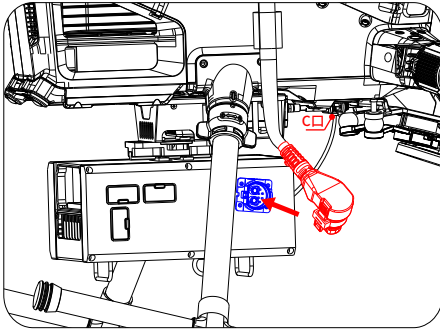

4.4 TK4 地面端与天空端的连接教程

4.4.1 接电顺序:连接电源线并接通市电后,再打开紧急断电开关
打开地面端电源开关:开启地面端,开关打到“ON”。

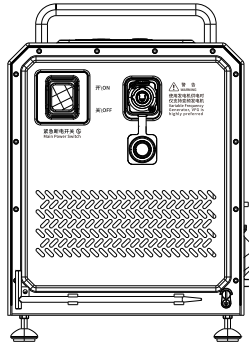

4.4.2 地面端开机:长按【】电源按钮,设备开机。



TK4系留供电系统用户手册

4.4.3 航空插头连接:打开导线盖,拉出系留线缆。*注意:拔出航空插头时按住银色金属按压位,航空插头松动后再拔出插头。

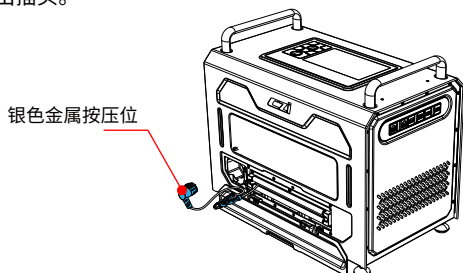

4.4.4 将系留线缆上的挂钩扣到天空端底部的系留线吊环上;然后打开天空端插头保护盖将地面端的航空插头与天空端接头以正确的方向连接,直至听见“咔嗒”一声,即为连接成功;完成后检查是否连接牢固,并检查地面端插头朝向是否正确。

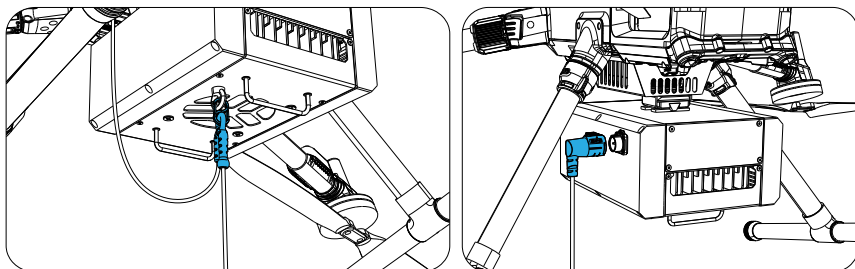

4.4.5 将无人机放置在合理作业场地,戴上静电手套。(详见安全使用事项)

打开系留电池的【】按键,无人机进行自检,等待无人机完成自检。

4.4.6 长按地面端的【】按键,听到“开启高压”的声音,即打开高压输出。

4.5 遥控设置教程

4.5.1 打开遥控,进入飞行界面。

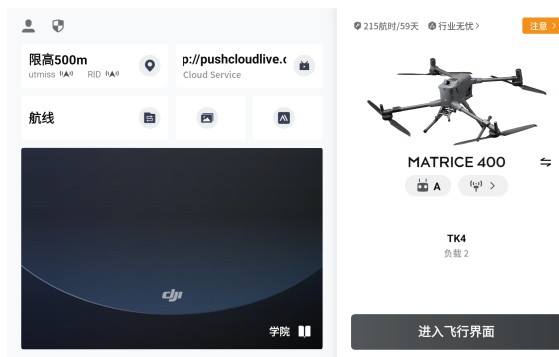

4.5.2 打开psdk栏,如下图所示。



4.5.3 点击浮窗开关,可以查看实时参数,如下图所示。



4.5.4 点击高压开关,可以控制地面端打开高压,如下图所示。



4.5.5 点击开灯按键,可控制矩阵灯开启,如下图所示。



4.5.6 点击亮度调节控件,可控制矩阵灯亮度,如下图所示。



4.5.7 点击收线控件,可控制地面端进行收线,如下图所示。



五、产品使用介绍

5.1 按键板

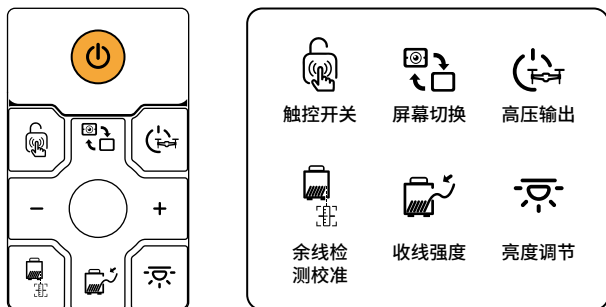

5.2 长按开/关机

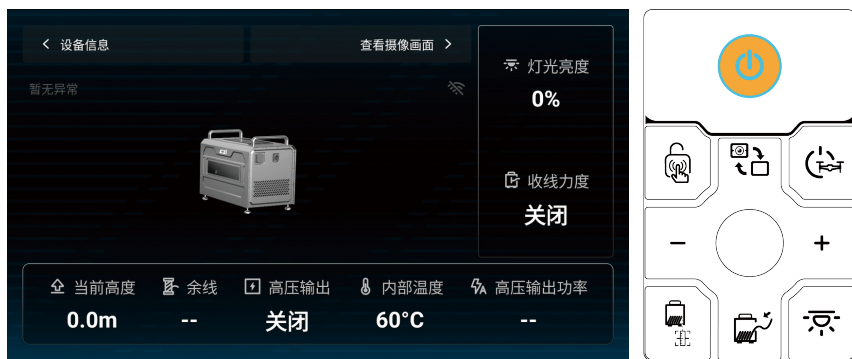

● 电源按键【】:

关机状态下, 长按3秒设备开机, 按键由白色灯变为蓝色灯;

开机状态下, 先短按1秒显示屏提示是否确认关机, 3秒内再次按下代表确认关机, 但此方式不适用于高压开启情况。

开机状态下, 长按3秒强制关机, 此方法无视高压是否开启, 无视飞机是否起飞, 有安全隐患, 仅作为紧急情况使用。

5.3 开启/关闭高压输出按键【】:

长按3秒, 按键白色灯变成蓝色灯, 开始输出高压;

再次长按3秒, 按键蓝色灯变成白色灯, 停止输出高压;

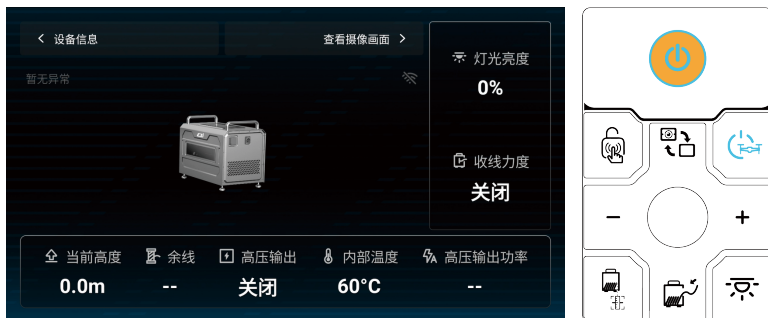

5.4 起飞/降落

- 使用大疆遥控器控制飞机起飞/降落

5.5 设定高度



- 使用大疆遥控器调节飞机高度, 由于线缆长度受限, 飞行高度请勿超出100m

5.6 余线检测重置

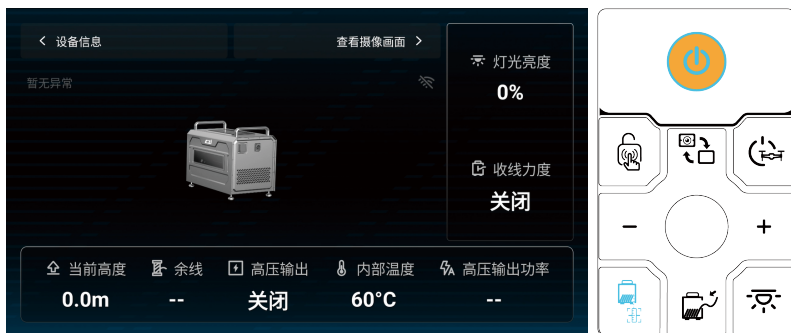
- 长按【】按键5秒, 将余线复位。



5.7 灯光亮度

- 可调节灯光亮度(刻度10%)最高值100%, 最低值0
- 没起飞前灯光亮度默认为0, 点击灯光亮度按键【】, 此按键及 +/- 两个按键变成亮蓝灯, 按下 +/- 按键后, 调节一次亮度±10%, 最大亮度限制为10%
- 起飞后, 点击灯光亮度按键【】, 此按键及 +/- 两个按键变成亮蓝灯, 按下 +/- 按键后, 调节一次亮度±10%, 亮度调节范围(0-100%)
- 自动开灯: 无人机起飞, 高度3米时, 照明灯自动开启10%亮度, 高度超过10米后, 照明灯自动开到100%。
- 自动关灯: 无人机降落, 高度降落到10米时, 照明灯自动调整到10%亮度, 高度降落到3米时, 照明灯自动关灯。
- 手动控制: 无人机起飞后任何高度允许手动控制0-100%灯光亮度。

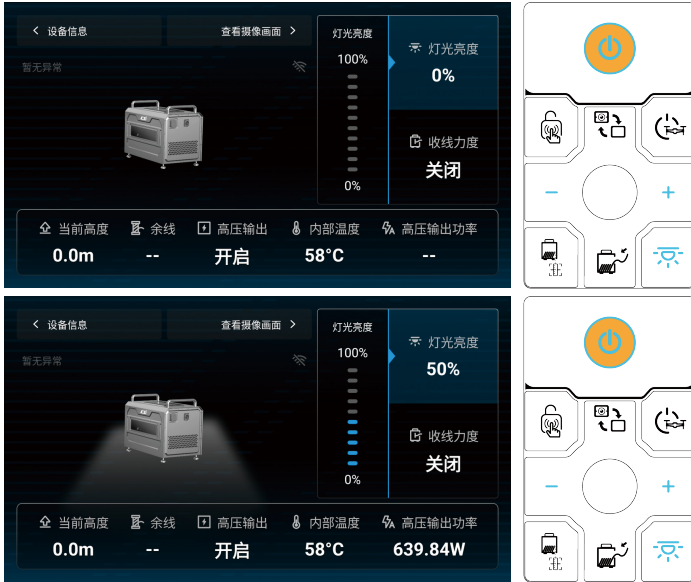

5.8 收线力度

- 可调节收线力度，挡位(关、自动、弱、中、强)，开机默认【自动】挡位
- 点击收线强度按键，按下此按键时，此按键及+/-两个按键变成亮蓝灯，+/-两个按键功能变为按下后，调节一次收线强度
- 当处于自动挡位时，产品将根据无人机的状态自动调节收线力度，以保证系留线笔直拉伸。
- 弱挡位和中挡位、强挡位都是默认的力度。

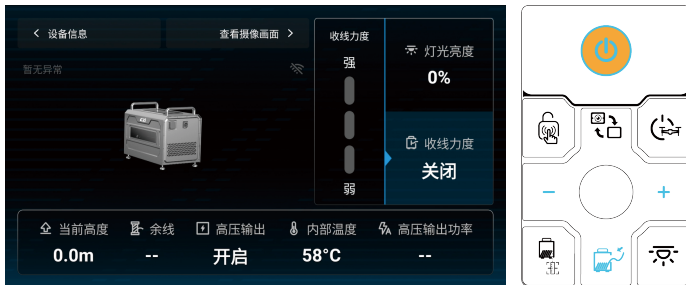

5.9 设备信息

- 飞行记录：可查看飞行日期、飞行时长、飞行最大高度，支持排序查询功能。



5.10 固件升级方法

首次使用或版本有更新则需要进行固件升级

- 离线固件包可从成至官方网站下载至外置存储设备(如TF卡、U盘)。运行czi GC App, 进入设备信息页面, 点击固件版本, 选择离线升级全部, 可从外置存储设备中选择所需的固件包, 进行一键升级。

注意事项

- 升级前确保无人机已与地面端连接, 开启高压。
- 升级过程中请勿操作按键板或关闭设备电源。
- 升级时, 务必使无人机远离人群及动物。
- 务必将固件更新至最新版本以保证飞行安全。

固件升级详细操作流程:

- 打开czi GC App后点击【设备信息】->【固件版本】, 选择合适的升级方式。

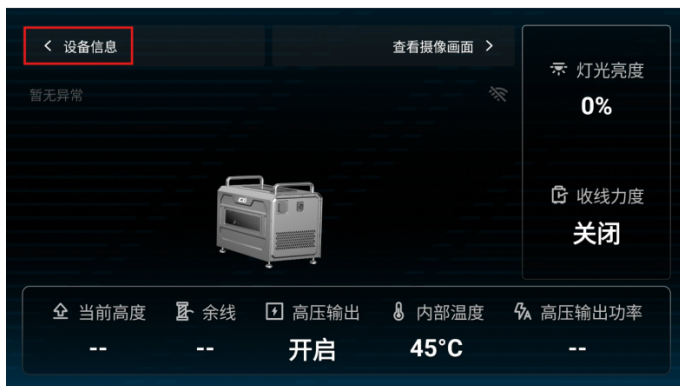

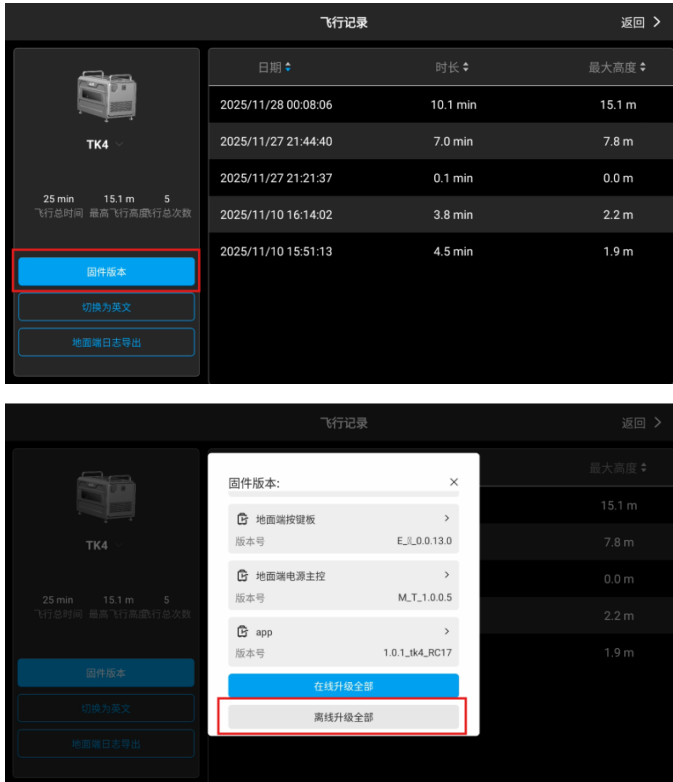

离线升级教程：

- 选择离线升级全部后，需要从U盘中选中下载的升级文件。

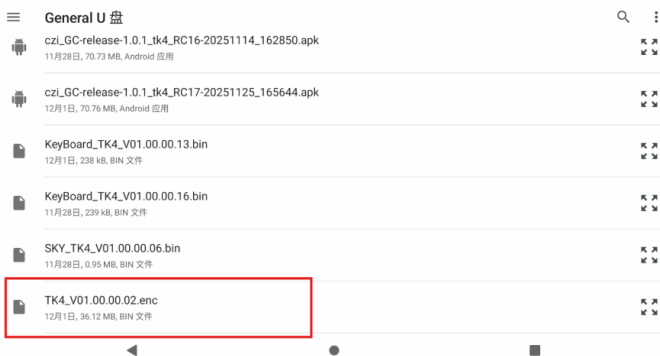

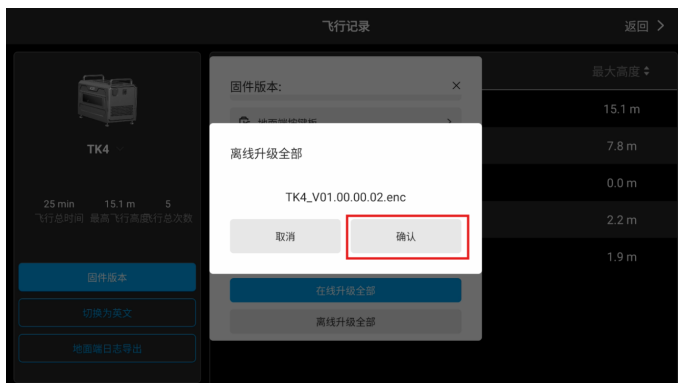

升级过程中需要5-10分钟, 升级时请勿断电, 等待升级完成。

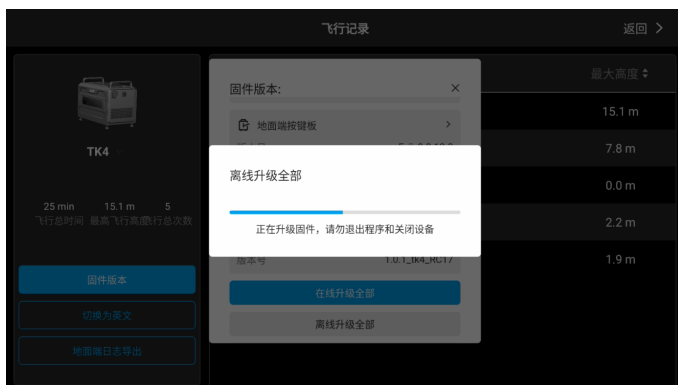

5.11 日志导出方法

1. 运行日志的导出方式为: 插入U盘, 打开文件管理器, 点击rk3568, 这是内部存储路径, ESD-USB是U盘存储路径, 不同的U盘可能存在不同的命名。

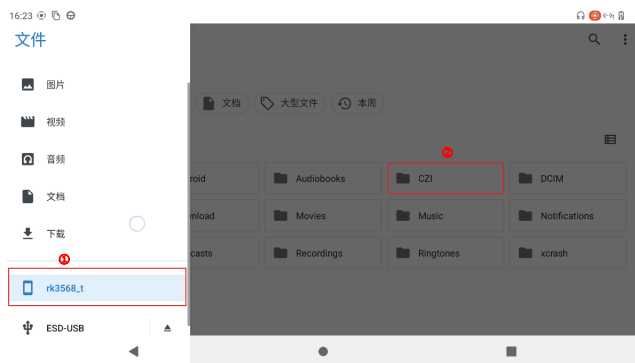



2. 把内部存储目录下 CZI/LOG 目录下的文件全部复制到U盘即可, 长按选中需要拷贝的文件(文件夹或压缩包都可以), 然后点击右上角复制到...

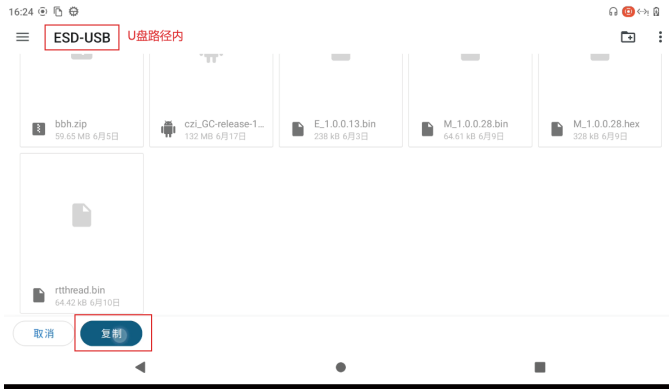

3. 选中U盘目录, 点击复制。





六、使用后拆卸及回收TK4 — 地面端的拆卸：(地面端拆卸之前确保关闭高压)

1. 长按地面端的“”按键,听到“关闭高压”的声音,即关闭高压输出,“”按键亮蓝灯熄灯。

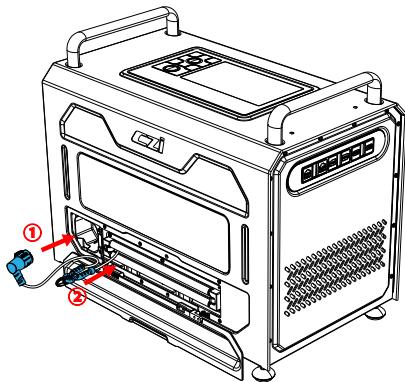

2. 取下航空插头:解开挂钩,将“航空插头”从天空端接口取下,通过地面端收回系留线缆,插头收回至箭头1所示方向,挂钩收回至箭头2所示方向,关闭导线盖;



3. 地面端关机:长按电源按钮【】,设备关机;



4. 地面端紧急断电开关:关闭地面端,开关打到“OFF”;

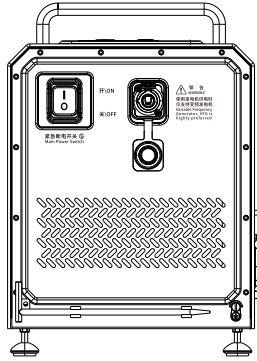

5. 地面端电源断开:电源线按钮往箭头 1 所示方向滑动,同时逆时针方向旋转,将电源线接头从插座上拔下,把线收回并盖上电源盖;

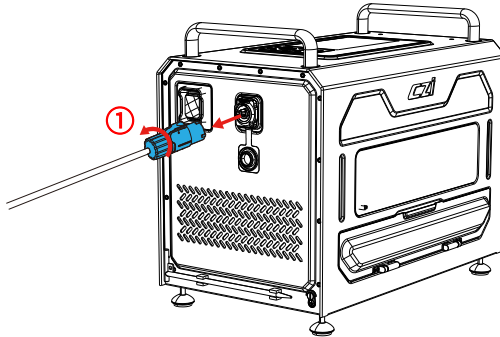

6. 220V电源断开:将电源插头从市电(或者发电机)插座拔出;

7. 接地针回收:将接地针拔出,收回底部并关闭底部接地盖;

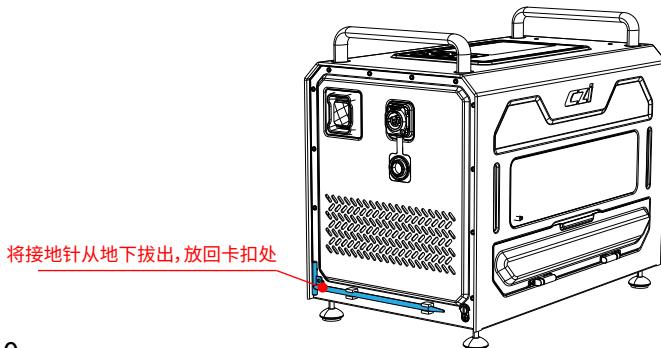

8. 收纳: 将地面端放进背包里;

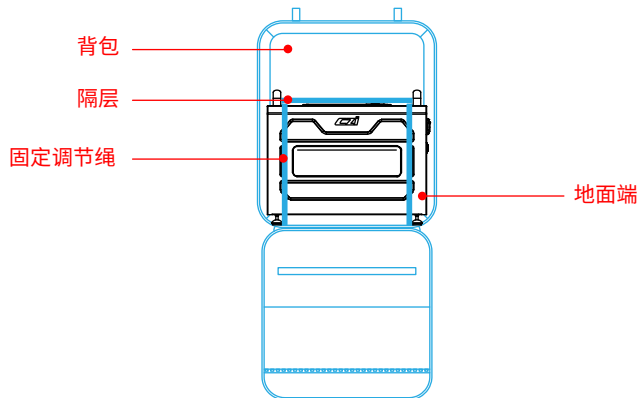

TK4-天空端的收纳:

1. 将电源、c口拔出。
2. 将天空端从飞机拆下来。

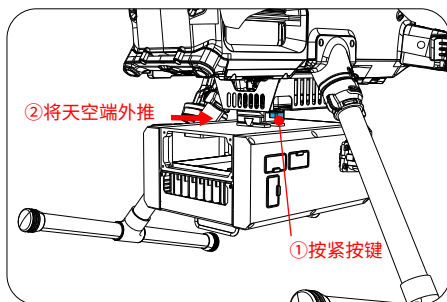

3. 收纳: 将天空端放进背包里。

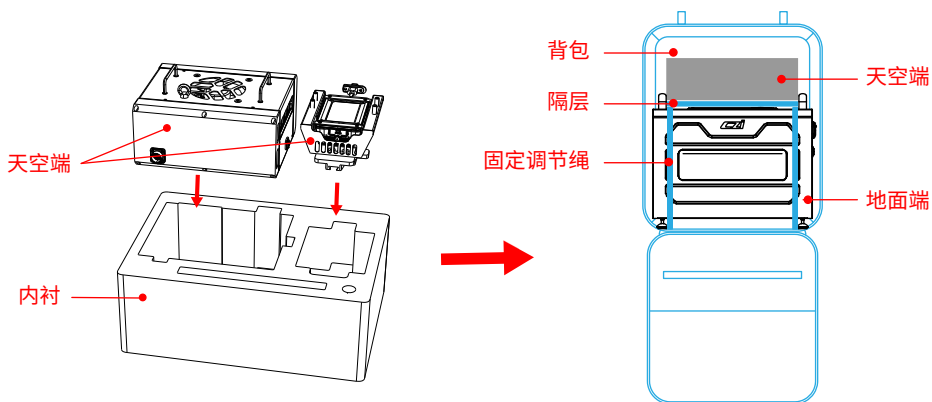

七、附录1:经测试可兼容的发电设备示例

⚠️ 声明:用户自行确认第三方发电机的安全性及合规责任。推荐兼容设备列表仅供参考,TK4系留供电系统不对第三方发电机的质量、安全性及后续固件更新承担责任。使用中如遇冲突,建议优先联系对应发电机制造商。

推荐使用配套的发电机如下

产品型号	神驰SC8000iF
最大功率(kw)	6.5
额定功率(kw)	6.0
额定电压(V)	230
额定频率(Hz)	50

TK4系留供电系统连接发电机的操作步骤:

- 1.根据发电机的使用说明,启动发电机组。
在发电机组启动之前,请勿连接TK4系留供电系统。
- 2.根据发电机的使用说明,将发电机电压调到适配TK4系留供电系统的电压(本设备建议220V)。
- 3.发电机组启动之后,将TK4电源线(客户自适配插头)连接到发电机上。
- 4.再根据TK4的操作步骤开启TK4系留供电系统。



⚠️ 注意,发电机在加机油时需将TK4产品的电源线与发电机断开,并将本产品远离发电机。

八、产品官网链接

详细的使用说明可以查阅电子版说明书(成至官网->服务与支持->下载中心->说明书下载)或产品教学视频(成至官网->服务与支持->下载中心->教学视频);



成至官网:www.czi.com.cn



请扫码查看最新《用户手册》

成至技术支持

www.czi.com.cn

服务热线: 400-008-8306

如你对说明书有任何疑问或者建议

请通过以下电子邮箱联系我们:

czzn@czi.com.cn

Made in China

View/Download Digital Version

Note: This document will be continuously updated and improved. The latest version will be available in digital format. Please refer to the latest version of the User Manual for accurate information. You can scan the QR code to view or download the latest TK4 Tethered Power System User Manual.



1. Disclaimers and Warnings

Thank you for purchasing czi products. The contents mentioned herein are related to your safety, legal rights and responsibilities. Failure to follow and comply with the instructions and warnings in this document may result in injury to you and others, damage to the product or other surrounding items. This document and all related documents are subject to the final interpretation of czi. Updates are subject to change without notice. Please visit the official website at www.czi.com.cn for the latest product information.

Warnings

Safety Guide

- ① Read this manual carefully before use and ensure the TK4 tether cable is properly connected to the aircraft. To prevent the rotating propellers from striking the tether cable, securely fasten the hook on the tether cable to the suspension ring on the airborne unit.
- ② When operating the aircraft, do not continue to increase flight altitude once the 5-meter remaining cable mark is visible at the ground station. Do not pull or tension the tether cable manually. Failure to follow this notice may result in cable breakage, equipment crash, personal injury, or third-party property damage, for which the operator shall bear full responsibility.
- ③ Please ensure that the AC input voltage from the wall power socket is within the range of 176–264 V. This device is recommended to be powered by wall power. If wall power is unavailable, it is recommended to use a matching inverter. This helps prevent equipment failure caused by unstable or insufficient power supply.
- ④ When wall power is not available, the device only supports inverter generators as an external power source. To avoid overload or underload caused by excessive power fluctuations during operation, do not use fixed-frequency generators to power the device. After rigorous testing by our technical department, the following generator model has been confirmed to be fully compatible with this product, with stable and reliable performance. Recommended Model: Senci SC8000iF inverter generator (see Appendix 1 for details).

 The recommended compatible generator models are provided for reference only. The TK4 Tethered Power System assumes no responsibility for the quality, safety, or subsequent firmware updates of any third-party equipment. In the event of any compatibility issue during use, it is recommended to contact the corresponding equipment manufacturer first.

- ⑤ For safety, when using wall power, ensure that the wall power socket is capable of delivering at least 4500 W output. The voltage and current of the wall power supply must be stable and reliable.

TK4 Tethered Power System User Manual

- ⑥ During aircraft flight, do not disconnect the wall power plug or power off the device.
- ⑦ Power connection sequence: First connect the power cable and supply power from the wall power socket, then turn on the main power switch.
- ⑧ When using this device, ensure the aircraft tether battery level is not lower than 60%.
- ⑨ Before takeoff, turn on the "Main Power Switch"; otherwise, the aircraft will not be able to take off.
- ⑩ To prevent accidents, do not use the system in rain, snow, frost, fog, thunderstorms, hail, sandstorms, or strong wind conditions.
- ⑪ To prevent accidents, never touch the TK4 tether cable (800V high voltage) with bare hands at any time. If live contact is unavoidable, always wear insulated gloves (with insulation rating exceeding 800V).
- ⑫ When using this device near high-voltage towers or when the system is not connected to the wall power, ensure an external grounding rod is properly installed.
- ⑬ To ensure proper heat dissipation, keep all ventilation and air intake openings unobstructed to prevent internal heat accumulation and overheating risks.
- ⑭ When the TK4 airborne unit been installed to M400, there is one gimbal Skyport it can be applied at the front.
- ⑮ ML200 matrix lighting gear (to be fasten on the M400 legs) is not ready for overseas market, since this would accumulates the TK4 overall power output to 4,000 watts. Without the lights, TK4 max power rate is 1,500-2,500 watts.

2. Overview

The CZI TK4 Ground Tethered Power System is a high-performance tethering solution designed for extended drone operations. Utilizing efficient power conversion technology, it converts AC power into high-voltage DC and transmits it to the airborne unit through the tether cable. The airborne unit then steps down the high-voltage input into low-voltage power that can be directly used by the drone's tethered battery, providing ample and continuous power to both the propulsion system and mission payloads. The system features a lightweight design, a high-definition display, and a built-in backup power source, ensuring stable operation even in harsh environments. With excellent protection performance, the TK4 is ideal for applications such as emergency lighting and security monitoring, enabling drones to achieve uninterrupted, around-the-clock flight operations to meet the demands of complex missions. This product is compatible with two mounting brackets (Bracket A and Bracket B). Please refer to Section 4.3 "TK4 Airborne Unit Installation" for relevant details.

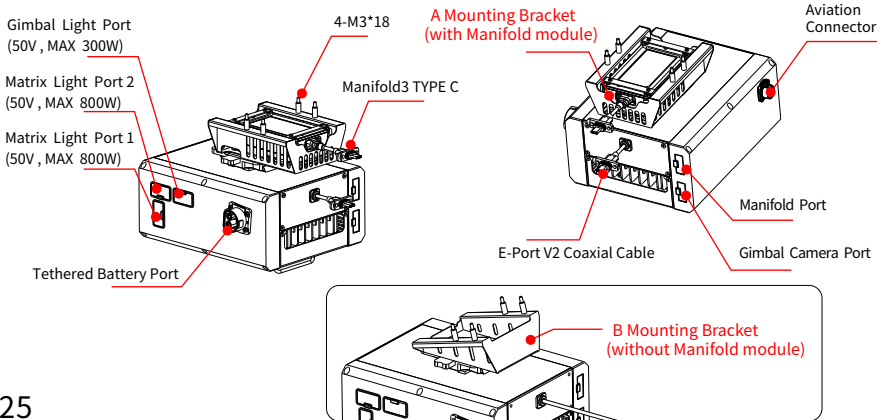

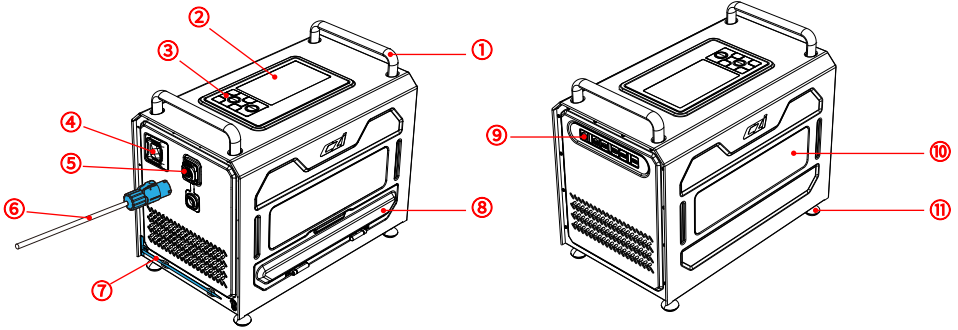

- ① Handle
- ② Display
- ③ Button Panel
- ④ Main Power Switch
- ⑤ Power Input Port
- ⑥ Power Cable
- ⑦ Grounding Rod
- ⑧ Cable Cover
- ⑨ External Device Interface
- ⑩ Viewing Window
- ⑪ Foot Base

TF-SD Port: Used for data transfer and backup. Enables transferring and backing up data from the device to a TF card.

LAN Port: Connects to external computer devices for uploading video sources to local equipment over a local area network.

WAN Port: Connects to an external network for system updates or video source uploads via the internet.

USB-A Port: Provides USB host functionality, supporting USB communication and RTK cable connections.

Type-C Port: Provides fast power supply for mission devices (e.g., body-worn cameras), supporting 65W fast charging and PD 3.0 power delivery.

HDMI Port: Supports real-time transmission of 1080P high-definition video.

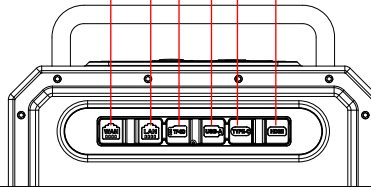

3. Specifications

TK4 Ground Station	
Dimensions	413*345*254mm (including handle and foot base)
Weight	≤13kg (including 110 m cable)
Input Voltage	176-264VAC (50/60HZ)
Output Voltage	800v

TK4 Tethered Power System User Manual

Output Power	4.5kw
Bandwidth	100M
Type-C Fast Charging Port	Max power: 65 W, supports PD3.0/QC protocols
Screen Size	5.5 inches
Screen Resolution	1920*1080
Backup Battery	2600mAh, 22.2v
Speaker Power	10W
Cable Length	110m
Cable Current Capacity	5A
Cable Voltage Rating	DC 2000V
Cable Weight	1.25kg/100m
Cable Tensile Strength	>50kg
Video Output Interfaces	HDMI, Ethernet
Max Operating Ground Elevation	4000m
Operating Temperature	-20°C~50°C (without solar radiation)
Storage Temperature	-40°C~+70°C

TK4 Airborne Unit

Dimensions	≤190*155*86mm(main body, excluding connectors)
Weight	≤2kg(main body, excluding mounting hardware)
Output Power	Rated 4000w
Output Voltage	50v
Video Input Interface	Type-c
Max Operating Ground Elevation	4000m
IP Rating	IP55
Operating Temperature	-20°C~50°C (without solar radiation)
Storage Temperature	-40°C~+70°C

4. Installation and Operation Guide

4.1 ML200-M400 Matrix Lights Installation Guide (If the matrix lights are not included at the time of purchase, please skip Sections 4.1)

4.1.1 Instructions

1. Align the clamp opening of the primary light unit with the landing gear crossbar (as shown in the left figure below), then press downward until the clamp securely attaches (as shown in the right figure below).

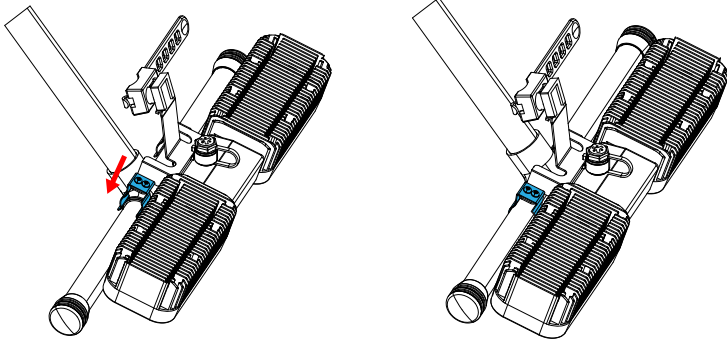

2. Repeat the process for the secondary light unit, as shown below.

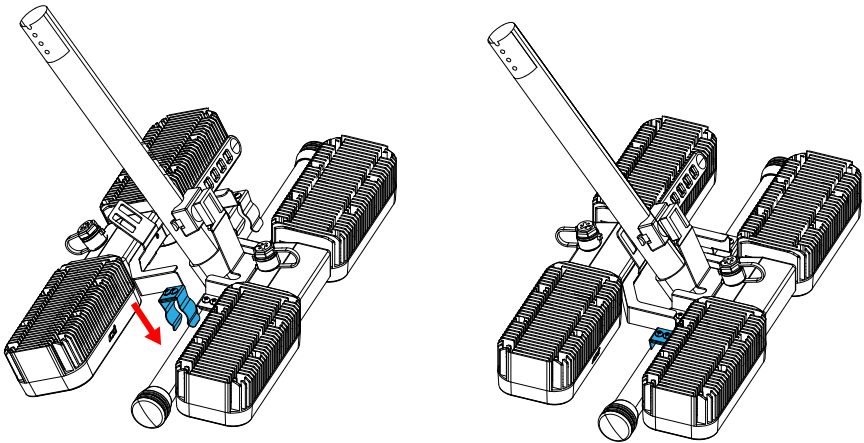

3. Thread the rubber strap through the connecting arm of the secondary light unit, pull it tight, and fasten it onto the buckle as shown below.

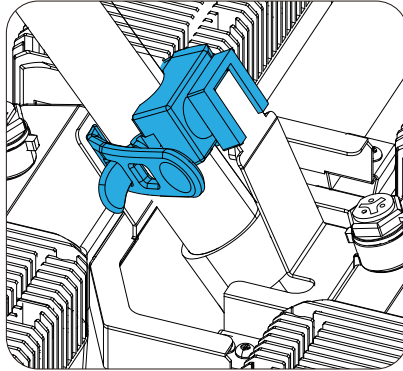

4. Connect the cables included with the product as follows:

- ① Plug in the two airborne-side connectors.
- ② Unscrew the waterproof cap on the light units before connecting the cable.
- ③ Connect the plugs to the light units and tighten the locking nut clockwise.
- ④ Route the cable along the two vertical landing gear bars as shown, and secure it using the velcro straps attached to the cable. Installation is now complete.

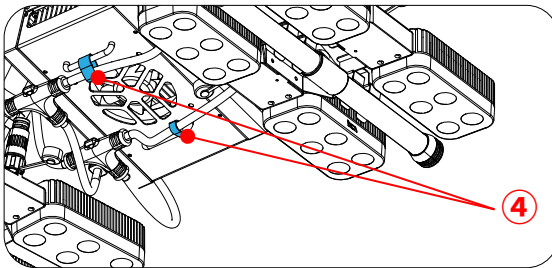
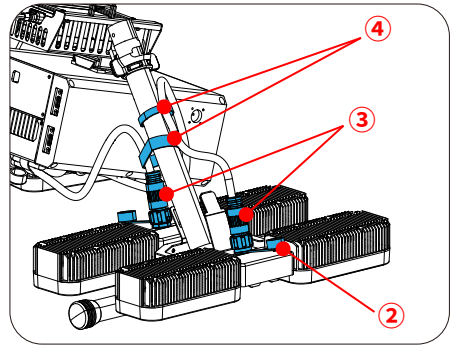
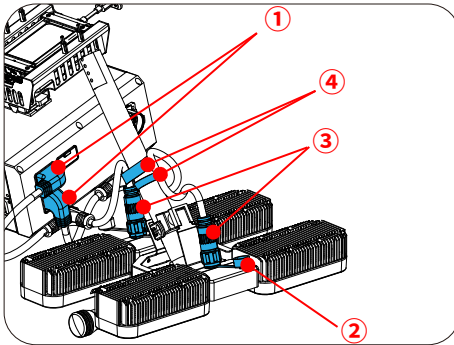

4.1.2 Control

After powering on, the ground station panel allows control of the light units.

4.2 TK4 Ground Station Installation

4.2.1 Grounding Rod Installation: Remove the grounding rod from the accessory kit. Loosen the hand-tightened screw on the grounding rod, secure the grounding cable, and insert the rod approximately 20 cm into the ground.

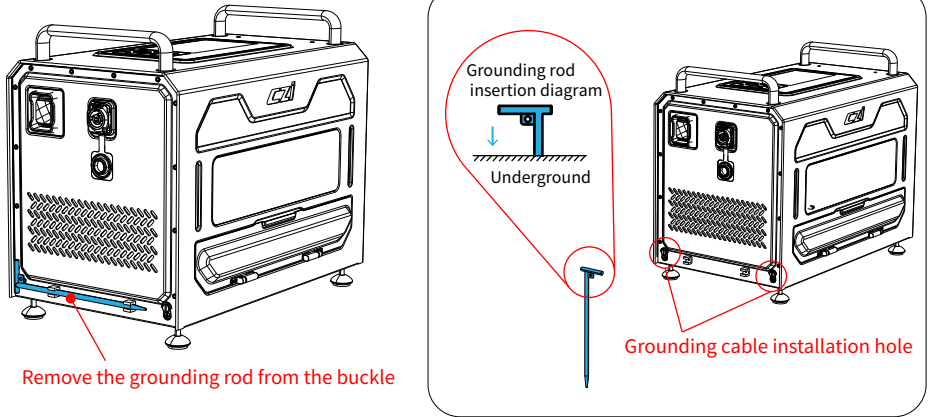

4.2.2 Ground Station Power Connection: Open the power port cover. Align the terminal block at position 1 with the power input port at position 2, insert, and rotate clockwise until a “click” is heard.

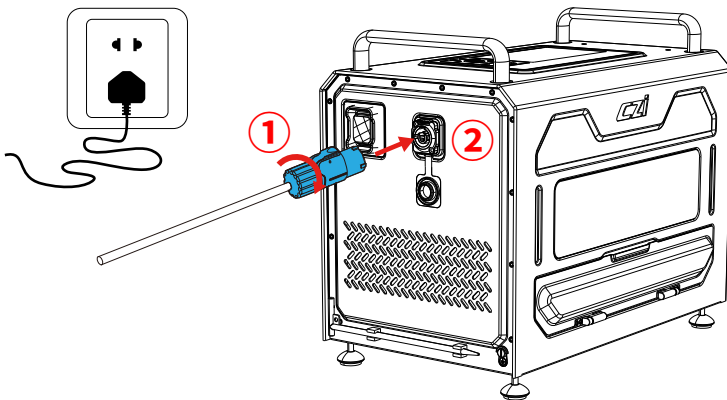

4.3 TK4 Airborne Unit Installation

4.3.1 Remove the TK4 airborne unit mounting bracket (Bracket A is pre-installed with the Manifold module, while Bracket B does not include the Manifold module). Align with the four screw holes on the bottom of the DJI M400 aircraft and fasten with four screws.

Bracket A (recommended for DJI single-gimbal configurations) compatible payloads include: Matrix Light ML200-M400, Gimbal Searchlight GL310, Gimbal Camera C50N, Relay CR20, DJI Gimbal Camera H30T, DJI Manifold 3.

TK4 Tethered Power System User Manual

Bracket B (recommended for DJI dual-gimbal configurations) compatible payloads include: Matrix Light ML200-M400, Gimbal Searchlight GL310, Gimbal Camera C50N, Relay CR20, DJI Gimbal Camera H30T.

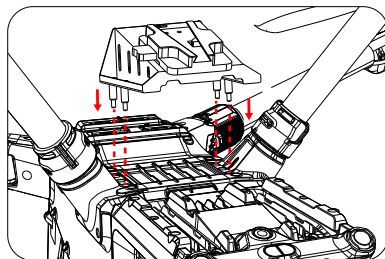
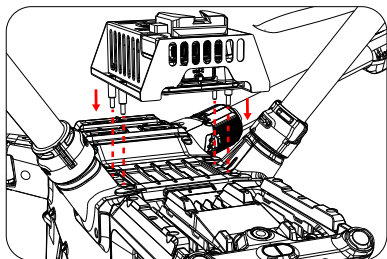

A Mounting Bracket (with Manifold module) – Illustration B Mounting Bracket (without Manifold module) – Illustration

4.3.2 Remove the TK4 main unit. Align the Y-shaped slider on top with the Y-shaped quick-release mount at the base of the bracket. Push it in until a “click” is heard. (Aircraft is hidden for clarity of the diagram).

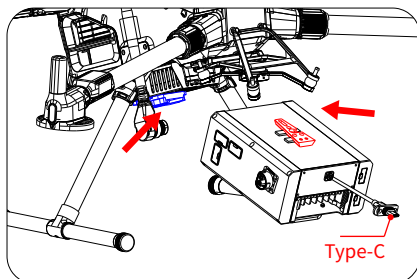

4.3.3 Connect the power plug (red) of the tethered battery on the aircraft separately to the power socket (blue) on the airborne unit. Then connect the Type-C cable of the airborne unit to the aircraft’s “E4” port, and use a screwdriver to tighten the two screws next to the Type-C port.

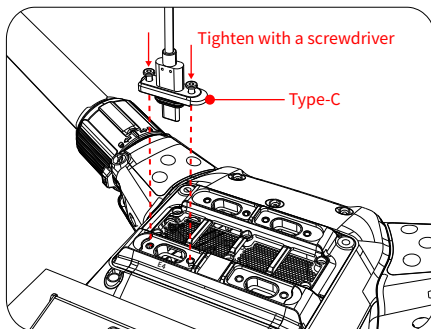
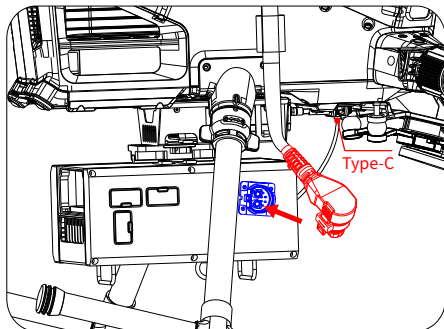

4.4 Connecting the Ground Station and Airborne Unit

4.4.1 Power connection sequence: First connect the power cable and supply power from the wall power socket, then turn on the main power switch.

Turn on the ground station power switch: Activate the ground station by setting the switch to “ON”.

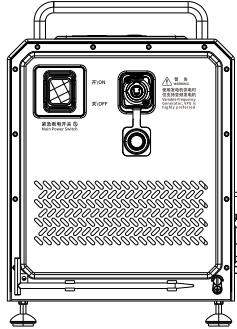

4.4.2 Start the ground station: Press and hold the [] power button to turn on the device.



4.4.3 Connect the Aviation Plug: Open the cable cover and pull out the tether cable. *Note: When disconnecting the aviation plug, press the silver metal button until the plug loosens, then pull it out.

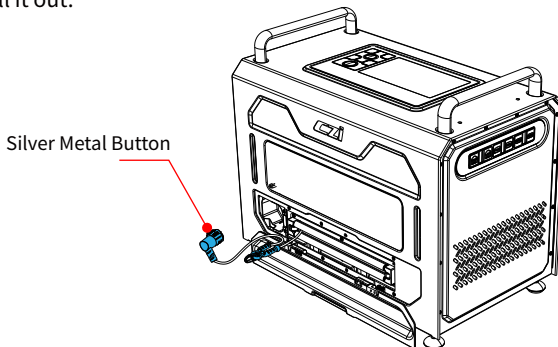

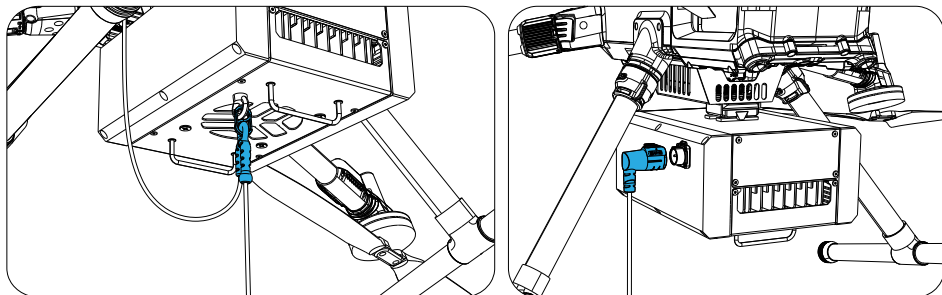

TK4 Tethered Power System User Manual

4.4.4 Attach the hook on the tether cable to the airborne unit’s tether ring. Then open the airborne unit connector cover and insert the aviation connector from the ground station into the airborne unit until a “click” is heard. After completion, verify the connection is secure and check that the ground station plug is oriented correctly.



4.4.5 Place the aircraft in a suitable operating area and wear anti-static gloves. (See safety precautions)

Press the [] button on the tethered battery to power on the system. The aircraft will begin a self-check. Wait until the self-check is completed.

4.4.6 Press and hold the [] button on the ground station until the voice prompt “High voltage on” is heard.

4.5 Remote Controller Settings

4.5.1 Turn on the remote controller and enter the flight interface.

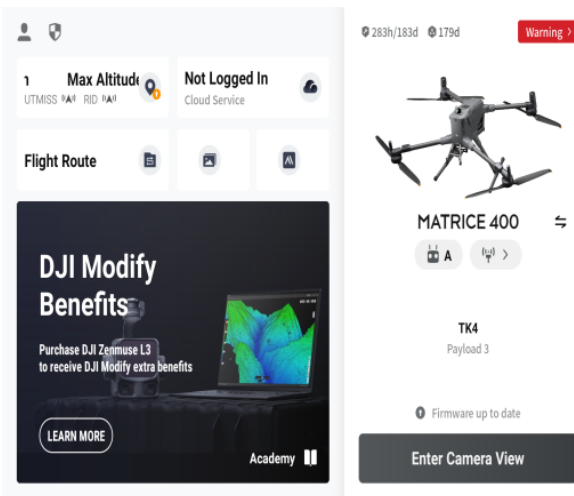

4.5.2 Open the PSDK section as shown below.

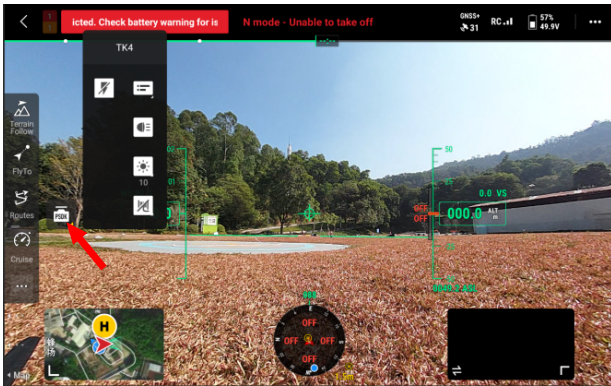

4.5.3 Tap the floating window switch to view real-time parameters, as shown below.

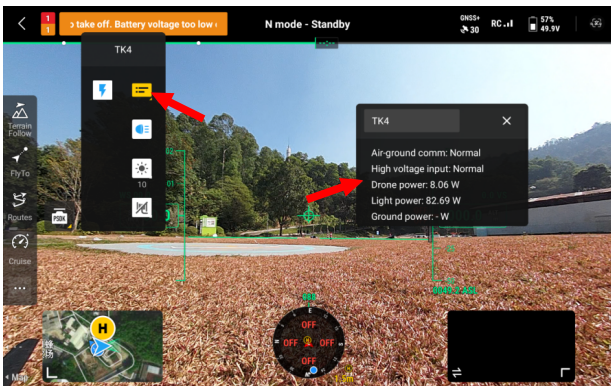

4.5.4 Tap the high voltage switch to turn on/off the ground station's high-voltage output, as shown below.



TK4 Tethered Power System User Manual

4.5.5 Tap the light switch to turn matrix lights on/off, as shown below.

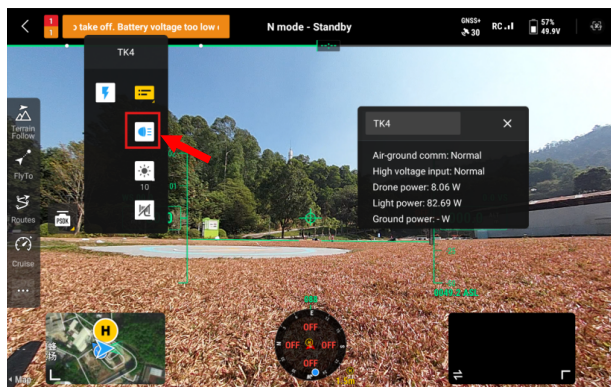

4.5.6 Tap the brightness adjustment control to change matrix light intensity, as shown below.



4.5.7 Tap the cable retraction control to retract the cable, as shown below.



5. Product Operation Instructions

5.1 Button Panel

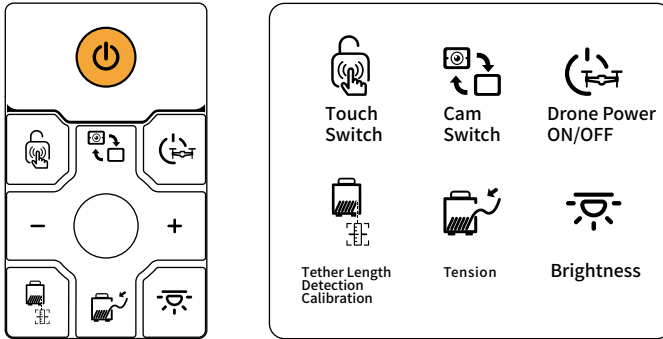

5.2 Power On/Off

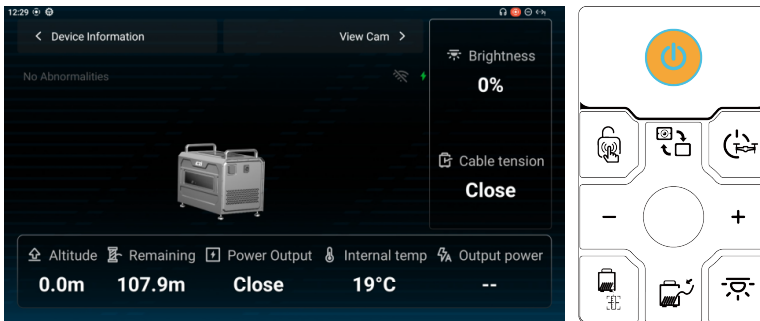

● Power Button []:

Power On: When the system is off, press and hold for 3 seconds to turn on. The indicator changes from white to blue.

Normal Shutdown: When the system is on, a short press of 1 second will initiate a shutdown confirmation prompt on the display. Press again within 3 seconds to confirm shutdown. (This method is not available when high voltage is active.)

Forced Shutdown: When the system is on, press and hold for 3 seconds to force shutdown. (This method works regardless of high voltage status or whether the aircraft is in flight. Use only in emergencies due to potential safety risks.)

5.3 High-Voltage Output On/Off Button []:

Press and hold for 3 seconds to activate high-voltage output. The indicator will change from white to blue.

Press and hold for 3 seconds again to deactivate high-voltage output. The indicator will change from blue to white.

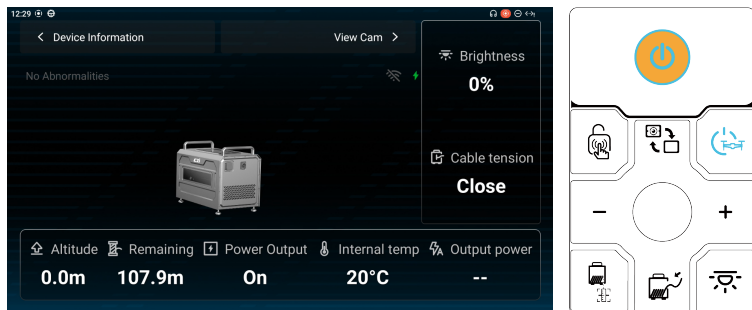

5.4 Takeoff/Landing

- Use the DJI remote controller to control aircraft takeoff and landing.

5.5 Set Flight Altitude

- Use the DJI remote controller to adjust the aircraft altitude. Due to the tether length limit, the recommended altitude is 100 m (when using a 110 m cable).

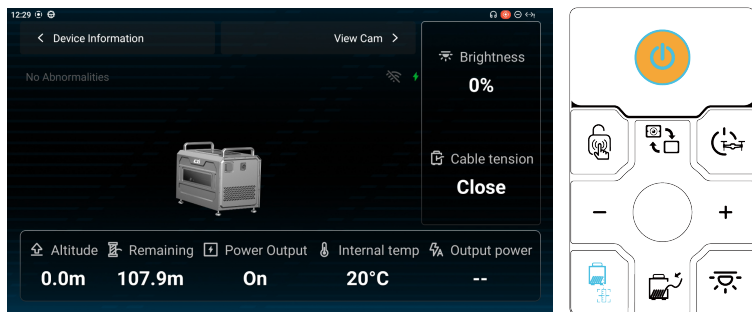

5.6 Remaining Cable Detection Reset

- Press and hold the [] button for 5 seconds to reset the remaining cable.



5.7 Light Brightness

- The light brightness is adjustable in 10% increments, from a minimum of 0% to a maximum of 100%.

- Before takeoff, the default brightness is 0. Tap the light brightness button []. The button and the +/- buttons will turn light blue. Press the +/- buttons to adjust brightness by $\pm 10\%$ per step. The maximum brightness before takeoff is limited to 10%.
- After takeoff: Tap the light brightness button []. The button and the +/- buttons will turn light blue. Press the +/- buttons to adjust brightness by $\pm 10\%$ per step within a range of 0 -100%.
- Automatic Lighting ON: When the aircraft takes off and reaches an altitude of 3 m, the lighting will automatically turn on at 10% brightness. When the altitude exceeds 10 m, the lighting will automatically increase to 100% brightness.
- Automatic Lighting OFF: During landing, when the aircraft descends to 10 m, the lighting will automatically adjust to 10% brightness. When the aircraft descends to 3 m, the lighting will automatically turn off.
- Manual Control: After takeoff, the lighting brightness can be manually adjusted between 0–100% at any altitude.

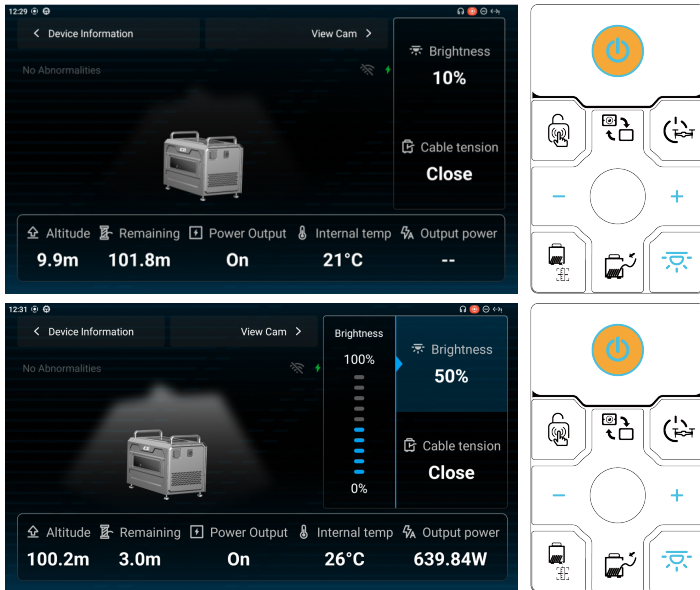

5.8 Cable Tension

- Adjustable Cable Tension with Modes (Off, Auto, Weak, Medium, Strong). Default mode on startup: [Auto].
- Press the Cable Tension button []. When pressed, this button and the +/- buttons will illuminate blue. The +/- buttons will then be enabled to adjust the Cable tension by one press each.
- When Auto mode is enabled, the system automatically adjusts the tension according to the aircraft's flight state to keep the Cable straight.
- The Weak, Medium, and Strong modes provide fixed tension levels by default.

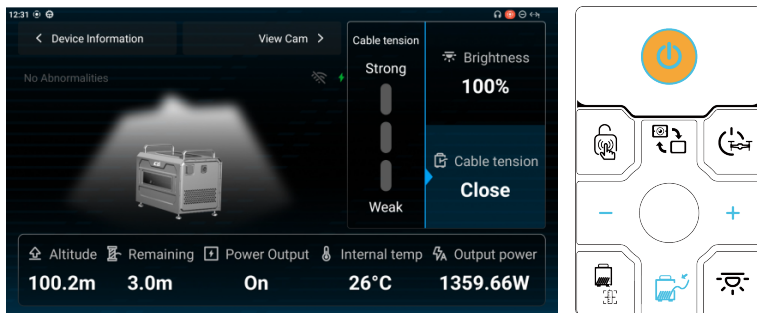

5.9 Device Information

● Flight Record: View flight dates, flight duration, and maximum flight altitude. Supports sorting and query functions.

The screenshot shows the 'Flight Record' interface. On the left, a summary for 'TK4' is displayed: 10 h 58 min, 111.1 m, and 14 flights. Below this are buttons for 'Firmware Version', 'Switch to Chinese', and 'Ground-based Log Export'. The main table lists flight records with columns for Date, Time, and Max Altitude.

Date	Time	Max Altitude
2025/12/28 11:25:37	22.6 min	2.0 m
2025/12/28 11:24:09	1.3 min	2.0 m
2025/12/27 03:43:47	4.9 min	10.9 m
2025/12/27 00:31:21	181.0 min	10.4 m
2025/12/26 21:47:21	4.5 min	10.7 m
2025/12/26 10:55:47	37.6 min	11.1 m
2025/12/24 01:37:18	310.9 min	11.1 m
2025/12/24 01:21:42	4.2 min	10.6 m

5.10 Firmware Update

Firmware updates are required during first-time use or when a new firmware version is released.

● Offline firmware packages can be downloaded from the CZI official website and saved to an external storage device (such as a TF card or USB flash drive). Launch the czi GC App, enter the Device Information page, tap Firmware Version, and select Offline Update All. Choose the required firmware package from the external storage device to perform a one-click upgrade.

Precautions

- Before updating, ensure the aircraft is connected to the ground station and high-voltage output is enabled.
- Do not operate the control panel or power off the device during the upgrade process.
- During the upgrade, keep the aircraft away from people and animals.
- Always update the firmware to the latest version to ensure flight safety.

Firmware Update Procedure:

- Open the czi GC App, then navigate to [Device Information] [Firmware Version], and select the appropriate update method.

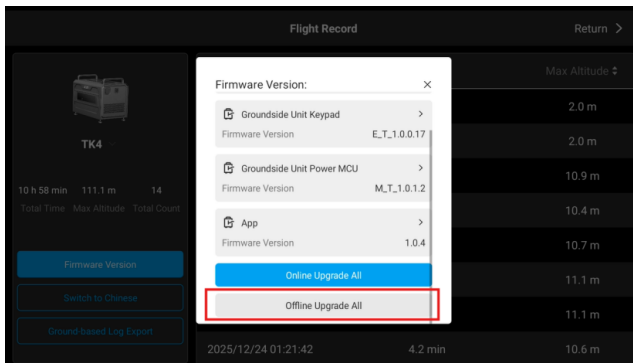
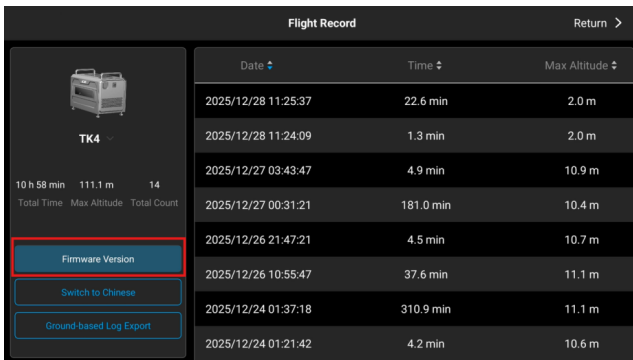
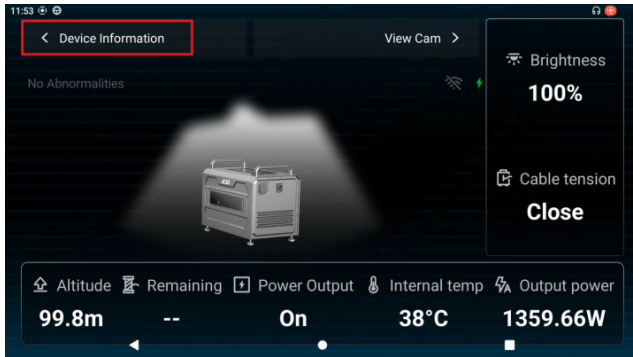

TK4 Tethered Power System User Manual

Offline Update:

- After selecting Offline Update All, choose the downloaded firmware file from the USB flash drive.

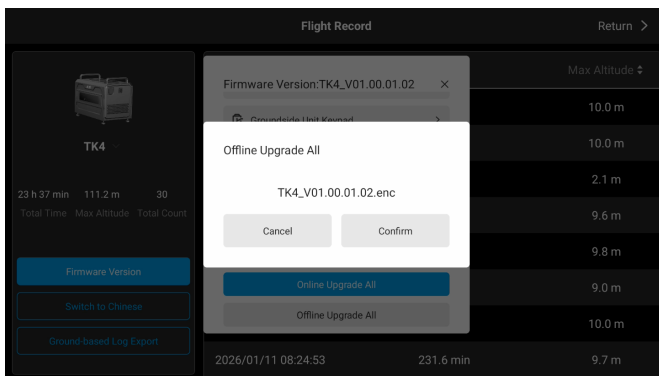
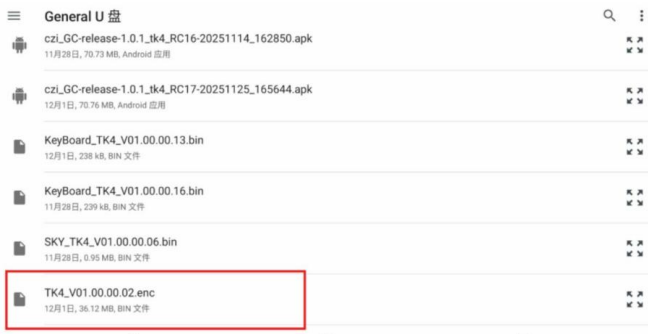

The update process takes approximately 5 -10 minutes. Do not power off the device during the update. Wait until the upgrade is completed.

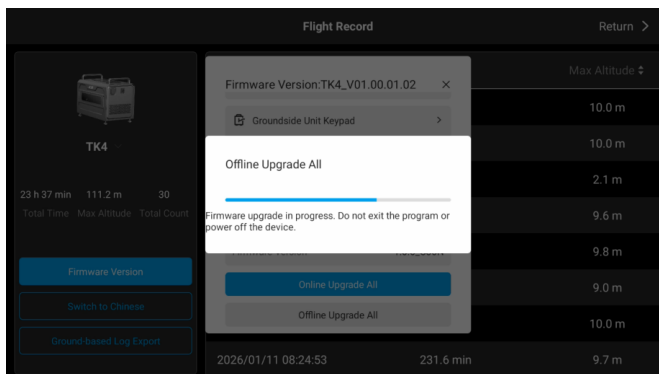

5.11 Log Export

1. To export the log file: Insert a USB drive, open File Manager, and tap rk3568. This is the internal storage path. ESD-USB is the USB drive storage path. Different USB drives may have different naming conventions.

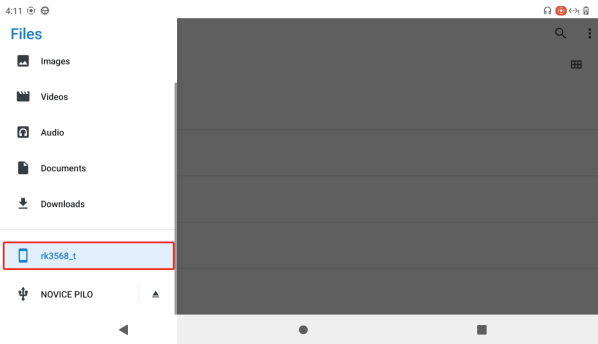

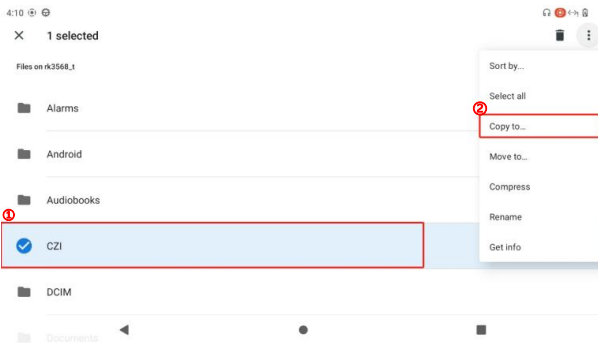

2. Copy all files from the CZI/LOG directory within the internal storage directory to the USB drive. Long-press to select the files that are to be copied (folders or compressed files are both acceptable), then tap the Copy to... button in the upper-right corner.

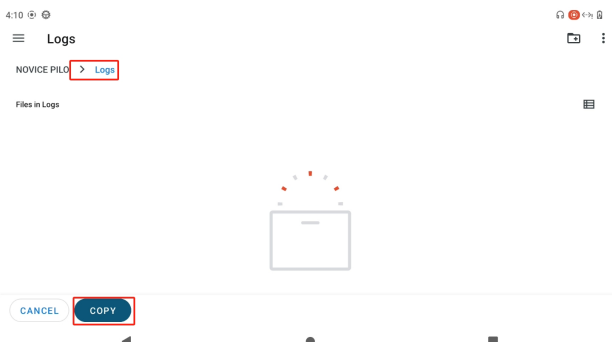

3. Select the USB drive directory, then tap Copy.



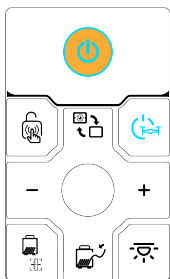

6. Post-Use Procedure (Ensure high voltage is turned off before proceeding.)

1. Press and hold the “” button on the ground station. When the voice prompt “High voltage off” is heard, the high-voltage output is turned off. The blue indicator light of the “” button will turn off.

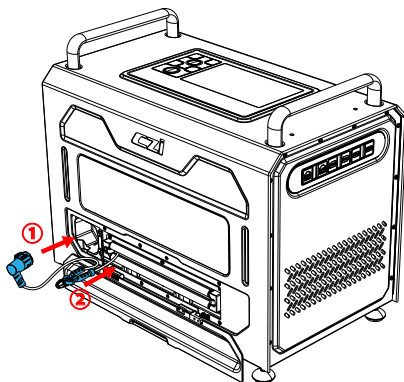

2. Remove the aviation connector: Unhook the latch, detach the “aviation connector” from the airborne unit interface, retrieve the tether cable via the ground station, retract the connector in the direction indicated by arrow 1, retract the latch in the direction indicated by arrow 2, and close the cable cover.



3. Ground Station power-off: Press and hold the power button [] to power off the device.

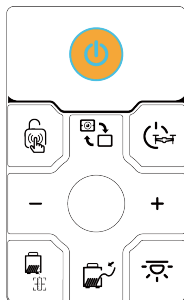

4. Ground Station main power switch: Turn off the ground station power by setting the switch to “OFF”.

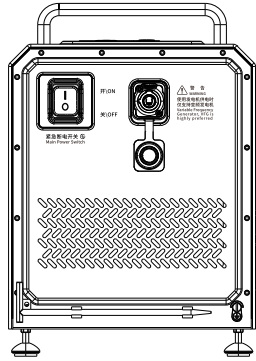

5. Disconnecting the Ground Station power supply: Slide the power cable button in the direction of arrow 1 while rotating it counterclockwise. Remove the power cable connector from the receptacle, retract the cable, and secure the power cover.

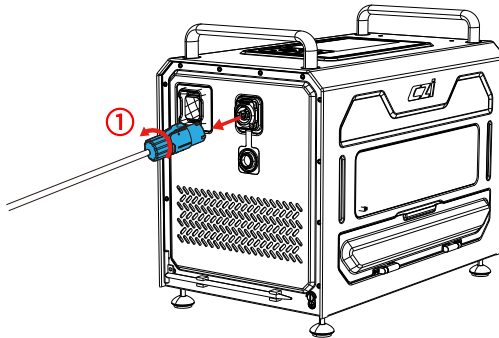

6. Disconnect 220V power supply: Unplug the power cord from the electrical outlet (or generator).

7. Grounding Rod Retrieval: Remove the grounding rod from the ground and secure it back into the holder clip.

Return the grounding rod to its holder

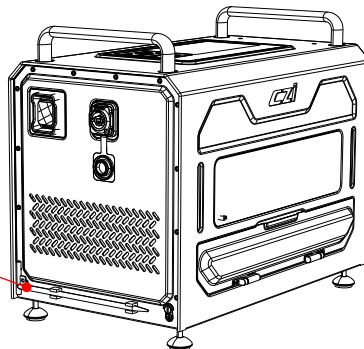

TK4 Tethered Power System User Manual

8. Storage: Place the ground station into the backpack.

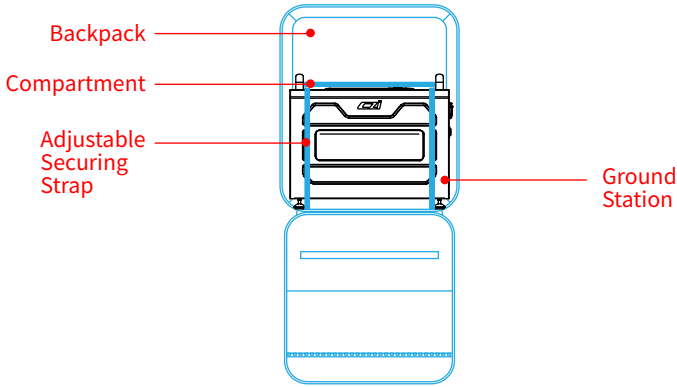

Airborne Unit Storage:

1. Disconnect the power and Type-C cables.
2. Remove the airborne unit from the aircraft mount.

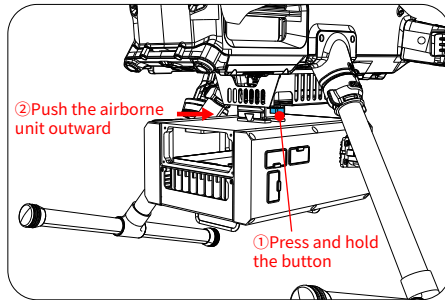

3. Storage: Place the airborne unit into the backpack.

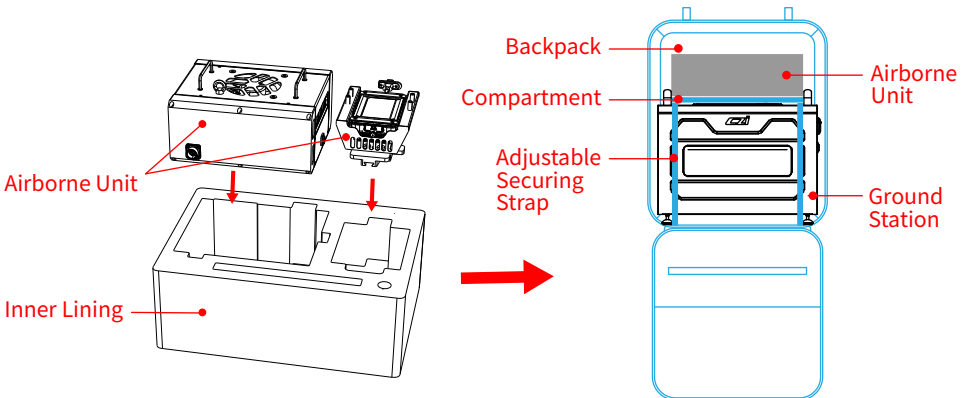

7. Appendix 1: Examples of Tested Compatible Generators

⚠ Disclaimer: The user is solely responsible for verifying the safety and regulatory compliance of any third-party generator. The recommended compatible equipment list is provided for reference only. The TK4 Tethered Power System assumes no responsibility for the quality, safety, or subsequent firmware updates of any third-party generator. In the event of any compatibility issue during use, it is recommended to contact the corresponding generator manufacturer first.

The following generator is recommended for use with the system:

Product Model	Senci SC8000iF
Max Output Power (kw)	6.5
Rated Output Power (kw)	6.0
Rated Voltage (V)	230
Rated Frequency (Hz)	50

Operating Steps for Connecting the TK4 Tethered Power System to a Generator:

1. Start the generator set according to the generator user manual.
2. Do not connect the TK4 Tethered Power System before the generator set is started.
3. According to the generator user manual, adjust the generator output voltage to a level compatible with the TK4 Tethered Power System. (The recommended voltage for this device is 220 V.)
4. After the generator set has started, connect the TK4 power cable (customer-supplied plug) to the generator.
5. Then power on the TK4 Tethered Power System by following the operating procedure for the TK4.



Insert the TK4 power cable

⚠ Caution: Before refueling the generator, disconnect the TK4 power cable from the generator and keep the TK4 product away from the generator.

8. Official Website Links

For detailed user instructions, please refer to: Electronic Manuals: [CZI Official Website -> Support -> Download Center -> Manuals -> TK4] Product Tutorial Videos: [CZI Official Website -> CZI Products -> TK4 -> Video]



CZI Official Website: www.czi.com.cn



Please scan the QR code to view the latest User Manual.

Chengzhi Technical Support

www.czi.com.cn

Service Hotline: 400-008-8306

If you have any questions or suggestions regarding the manual, please contact us via the following email address:

czzn@czi.com.cn

Made in China