

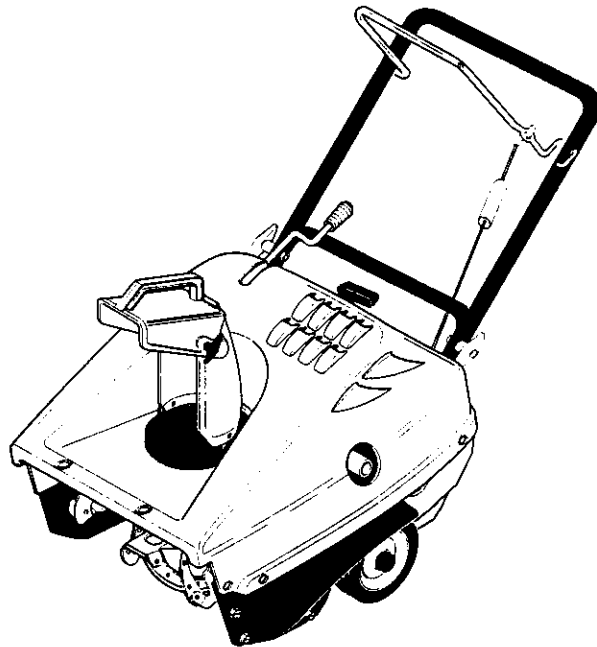

**5.0 Horsepower
21 Inch Single Stage
Auger Propelled
SNOW THROWER
Electric Start**

**MODEL NO.
536.885211**



**Caution:
Read and follow all Safety
Rules and Operating
Instructions before first use
of this product.**

SEARS, ROEBUCK AND CO., Hoffman Estates, IL 60179 U.S.A.

F001019M 04/27/99

SAFETY

ASSEMBLY

OPERATION

MAINTENANCE

PARTS LIST

ESPAÑOL



TABLE OF CONTENTS

Table of Contents	2	Service and Adjustments	12-15
Warranty	2	Storage	16
Safety Rules	2-4	Troubleshooting	17
Contents of Shipping Carton	4	Snow Repair Parts	18-24
Assembly	5	Engine Repair Parts	25-29
Operation	6-10	Spanish(Español)	30-46
Maintenance	11	Parts Ordering/Service	Back Cover

WARRANTY STATEMENT

LIMITED TWO-YEAR WARRANTY ON CRAFTSMAN SNOW THROWER

For two years from the date of purchase, when this Craftsman Snow Thrower is maintained, lubricated, and tuned up according to the operating and maintenance instructions in the owner's manual, Sears will repair, free of charge, any defect in material or workmanship. If this Craftsman Snow Thrower is used for commercial or rental purposes, this warranty applies for only 90 days from the date of purchase.

This warranty does not cover the following:

- Items which become worn during normal use, such as spark plugs, drive belts and shear pins.
- Repairs necessary because of operator abuse or negligence, including bent crankshafts and the failure to maintain the equipment according to the instructions contained in the owner's manual.

WARRANTY SERVICE IS AVAILABLE BY RETURNING THE CRAFTSMAN SNOW THROWER TO THE NEAREST SEARS SERVICE CENTER/DEPARTMENT IN THE UNITED STATES. THIS WARRANTY APPLIES ONLY WHILE THIS PRODUCT IS IN USE IN THE UNITED STATES.

This warranty gives you specific legal rights, and you may also have other rights which may vary from state to state.

Sears, Roebuck and Co., D817WA, Hoffman Estates, IL 60179



SAFETY RULES



 Look for this symbol to point out important safety precautions. It means--- **ATTENTION!!!** Become alert!!! Your safety is involved.

CAUTION: Always turn key to OFF position and remove key to prevent accidental starting when setting-up, transporting, adjusting or making repairs.

IMPORTANT: Safety standards require operator presence controls to minimize the risk of injury. Your snow thrower is equipped with such controls. Do not attempt to defeat the function of the operator presence control under any circumstances.

 **California Proposition 65**
WARNING: The engine exhaust from this product contains chemicals known to the State of California to cause cancer, birth defects or other reproductive harm.

BEFORE USE

- Read the owner's manual carefully. Be thoroughly familiar with the controls and the proper use of the snow thrower. Know how to stop the snow thrower and disengage the controls quickly.
- Do not operate the snow thrower without wearing adequate outer garments. Wear footwear that will improve footing on slippery surfaces.
- Keep the area of operation clear of all persons, particularly small children and pets.
- Thoroughly inspect the area where the snow thrower is to be used and remove all foreign objects.
- Use extension cords and receptacles as specified by the manufacturer for all snow throwers with electric drive motors or with factory-installed or optional starting motors.

- Use only attachments and accessories approved by the manufacturer of the snow thrower (such as electric starter kits, etc.).
- Never operate the snow thrower without good visibility or light. Always be sure of your footing, and keep a firm hold on the handles. Walk; never run.
- This snow thrower is for use on sidewalks, driveways, and other ground level surfaces. CAUTION: should be exercised while using on steep sloping surfaces. DO NOT USE SNOW THROWER ON SURFACES ABOVE GROUND LEVEL such as roofs of residences, garages, porches or other such structures or buildings.
- Check all bolts at frequent intervals for proper tightness to be sure the snow thrower is in safe working condition.
- Disengage clutch before starting the engine.
- Let engine and snow thrower adjust to outdoor temperatures before starting to clear snow.

FUEL SAFETY

- Handle fuel with care; it is highly flammable.
- Use an approved container.
- Check fuel supply before each use, allowing space for expansion as the heat of the engine and/or sun can cause fuel to expand.
- Fill fuel tank outdoors with extreme care. Never fill fuel tank indoors. Replace fuel tank cap securely and wipe up spilled fuel.
- Never remove the fuel tank cap or add fuel to a running or hot engine.
- Never store fuel or snow thrower with fuel in the tank inside a building where fumes may reach an open flame.

OPERATING SAFETY

- Never allow children or young teenagers to operate the snow thrower. Keep them away while it is operating. Never allow adults to operate the snow thrower without proper instruction.
- Do not operate this machine if you are taking drugs or other medication which can cause drowsiness or affect your ability to operate this machine.
- Do not use this machine if you are mentally or physically unable to operate this machine safely.
- Always wear safety glasses or eye shields during operation or while perform-

ing an adjustment or repair to protect your eyes from foreign objects that may be thrown from the snow thrower.

- Do not put hands or feet near or under rotating parts. Keep clear of the discharge opening at all times.
- Exercise extreme caution to avoid slipping or falling, especially when operating in reverse or backing up.
- Do not clear snow across the face of slopes. Exercise caution when changing direction on slopes. Do not attempt to clear steep slopes.
- Never operate the snow thrower without proper guards, plates, or other safety protective devices in place.
- Never operate the snow thrower near glass enclosures, automobiles, window wells, drop-offs, and the like without proper adjustment of the snow discharge angle. Keep children and pets away.
- Never operate the snow thrower at high transport speeds on slippery surfaces. Look behind and use care when backing.
- Never direct discharge at bystanders or allow anyone in front of the snow thrower.
- Do not run the engine indoors, except when starting the engine and for transporting the snow thrower in or out of the building. Open the outside doors; exhaust fumes are dangerous, containing CARBON MONOXIDE, an ODORLESS and DEADLY GAS.
- Take all possible precautions when leaving the snow thrower unattended. Disengage the auger/impeller, stop engine, and remove key.
- Do not overload the machine capacity by attempting to clear snow at too fast a rate.

SAFE STORAGE

- Always refer to the owner's manual instructions for important details if the snow thrower is to be stored for an extended period.
- Disengage power to the auger/impeller when snow thrower is transported or not in use.
- Never store the snow thrower with fuel in the fuel tank inside a building where ignition sources are present such as water and space heaters, clothes dryers, and the like. Allow the engine to cool before storing in any enclosure.

REPAIR/ADJUSTMENTS SAFETY

- After striking a foreign object, stop the engine (motor). Turn key to OFF position and remove key to prevent accidental starting. Thoroughly inspect the snowthrower for any damage, and repair the damage before restarting and operating it.
- If snow thrower should start to vibrate abnormally, stop engine (motor) and check immediately for the cause. Vibration is generally a warning of trouble.
- Stop the engine (motor) whenever you leave the operating position. Also, turn key to OFF position and remove key before unclogging the auger/impeller housing or discharge chute, and when making any repairs, adjustments, or inspections. Remove wire from spark plug to prevent accidental starting.
- When cleaning, repairing, or inspecting, make certain the auger/impeller and all moving parts have stopped. Turn key to OFF position and remove key to prevent accidental starting.
- Never attempt to make any adjustments while the engine is running except when specifically recommended by the manufacturer.
- Maintain or replace safety and instruction labels, as necessary.
- Run the snow thrower a few minutes after throwing snow to prevent freeze-up of the auger/impeller.

⚠ WARNING: This unit is equipped with an internal combustion engine and should not be used on or near any unimproved forest-covered, brush-covered or grass-covered land unless the engine's exhaust system is equipped with a spark arrester meeting applicable local or state laws (if any). If a spark arrester is used, it should be maintained in effective working order by the operator.

In the state of California the spark arrester is required by law (Section 4442 of the California Public Resources Code). Other states may have similar laws. Federal laws apply on federal lands. A spark arrester/muffler is available through your nearest Sears Authorized Service Center (See ENGINE REPAIR PARTS section in this manual).

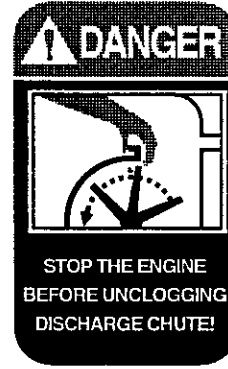

Contents of Parts Bag

- 1 - Owner's Manual (not shown)
- 1 - Parts Bag (not shown)



1 - 3.2 ounce container
Craftsman 2-cycle oil

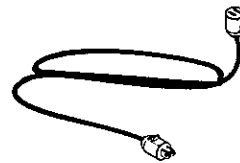

1 - Electric Starter Cord
10 ft.

ASSEMBLY

⚠ CAUTION: Always wear safety glasses or eye shields while assembling snow thrower.

TOOLS REQUIRED FOR ASSEMBLY

- 1 - Knife to cut carton

The figure to the right shows the snow thrower completely assembled.

References to the right or left hand side of the snow thrower are from the viewpoint of the operator's position behind the unit.

TO REMOVE SNOW THROWER FROM CARTON

- Locate and remove container of Craftsman 2-cycle oil.
- Remove the inserts positioned around the unit and the packing material.
- Cut down two corners nearest the handles and lay the panel down flat.
- Remove and discard bottom packaging.
- Pull snow thrower out of the carton.

TO ASSEMBLE THE SNOW THROWER

- Remove wrap on upper handle and along the side of both handles. Discard wrap.
- Unfold upper handle to remove packaging on the control panel and discard.
- Loosen the tee knobs on each side of the upper handle. See figure on this page.
- Raise the upper handle to the operating position.

NOTE: Make sure the cables are not caught between the upper and lower handle.

- Check to be sure the clutch cable is not caught in the handle. Tighten the tee knobs.

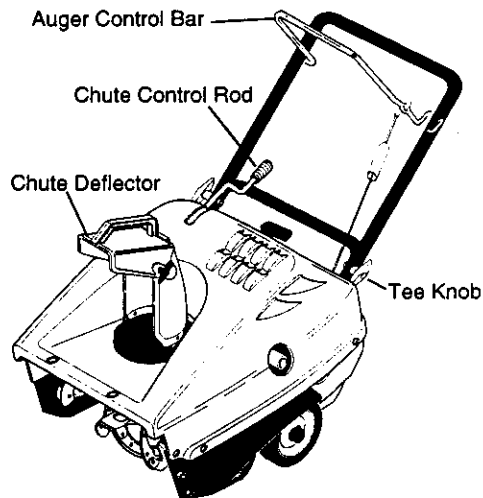

✓ CHECKLIST

Before you operate your new snow thrower, to ensure that you receive the best performance and satisfaction from this quality product, please review the following checklist:

- ✓ All assembly instructions have been completed.
- ✓ The discharge chute rotates freely.
- ✓ No remaining loose parts in carton.

While learning how to use your snow thrower, pay extra attention to the following important items:

- ✓✓ Make sure gas tank is filled with 40:1 ratio mixture of gasoline and oil.
- ✓✓ Become familiar with all controls-their location and function. Operate controls before starting engine.

OPERATION

KNOW YOUR SNOW THROWER

READ THIS OWNER'S MANUAL AND SAFETY RULES BEFORE OPERATING YOUR SNOW THROWER. Compare the illustrations with your SNOW THROWER to familiarize yourself with the location of various controls and adjustments. Save this manual for future reference.



Electric Start



Ignition Off



Ignition On



Spark Plug



Oil/Fuel Mixture



Primer Button

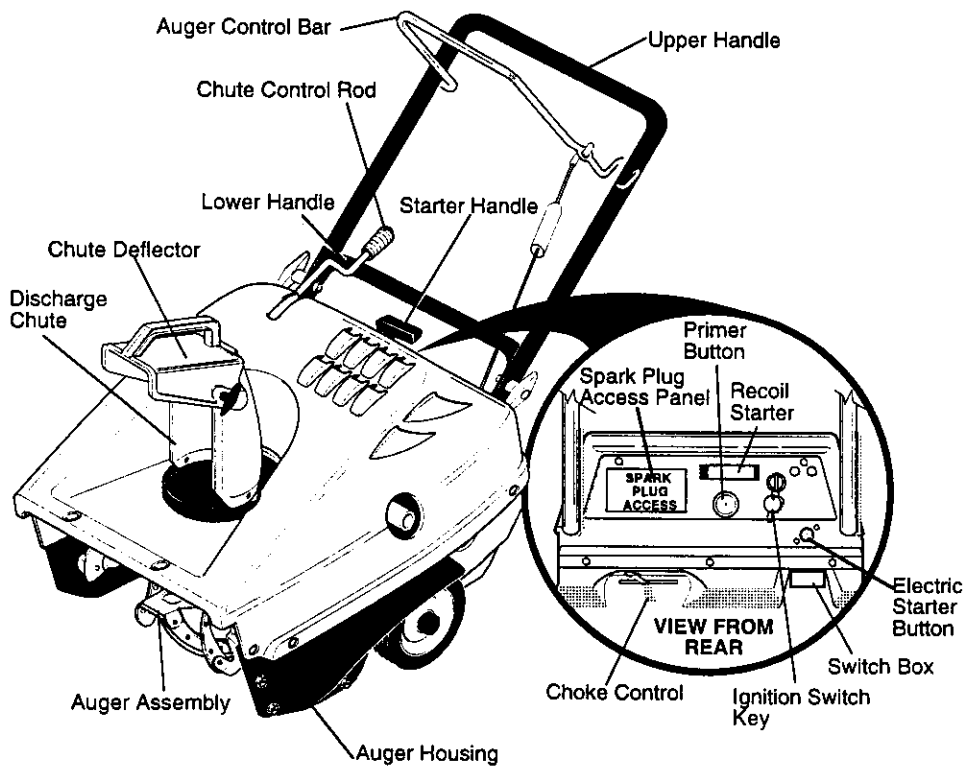

Auger Control Bar – Starts and stops the auger which propels the snow thrower.

Chute Control Rod – Changes the direction of snow discharge.

Chute Deflector – Changes the distance the snow is thrown.

Discharge Chute – Changes the direction the snow is thrown.

Ignition Switch Key – Must be inserted and turned to the ON position to start the engine.

Choke Control – Used to start a cold engine

Primer Button – Injects fuel directly into the carburetor manifold for fast starts in cold weather.

Recoil Starter Handle – Starts the engine manually.

Electric Starter Button – Used to start the engine using the 120V electric starter.

Spark Plug Access Panel – Aides in spark plug removal.

HOW TO USE YOUR SNOW THROWER

TO STOP YOUR SNOW THROWER

- To stop the auger, release the auger control bar.

NOTE: If the auger continues to creep, refer (To Adjust Auger Control Cable paragraph on page 12).

- To stop the engine, turn key to the OFF position.

TO CONTROL SNOW DISCHARGE

- Turn the chute control rod to set the direction of the snow throwing.
- Loosen the wing knob on the chute deflector and move the deflector to set the distance. Move the deflector (UP) for more distance, (DOWN) for less distance. Then tighten the wing knob (See figure below).

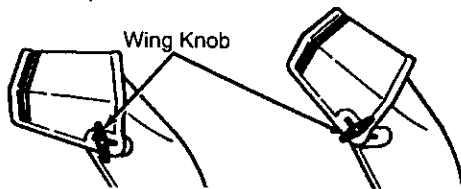

TO USE AUGER PROPEL ACTION

- Squeeze the auger control bar down against the upper handle to allow the auger to turn.
- To propel forward, raise the handle to allow the rubber auger blades to contact the ground (See figure below).

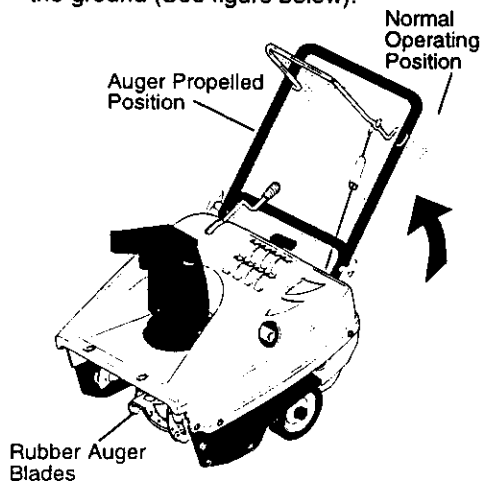

CAUTION: Read owner's manual before operating machine. Never direct discharge toward bystanders. Release the auger control bar and stop the engine before unclogging discharge chute or auger housing and before leaving the machine.

BEFORE STARTING ENGINE

WARNING: Experience indicates that alcohol blended fuels (called gasohol or those using ethanol or methanol) can attract moisture which leads to separation and formation of acids during storage. Acidic gas can damage the fuel system of an engine while in storage. To avoid engine problems, the fuel system should be emptied before storage for 30 days or longer. Start engine and let it run until fuel lines and carburetor are empty. Use carburetor bowl drain to empty residual gasoline from float chamber (See figure in Storage section, page 16). Use fresh fuel next season. (See Storage Instructions on page 16 for additional information).

Never use engine or carburetor cleaner products in the fuel tank or permanent damage may occur.

FILL GAS

NOTICE: ENGINES WHICH ARE CERTIFIED TO COMPLY WITH CALIFORNIA AND US EPA EMISSION REGULATIONS FOR ULGE ENGINES: Are certified to operate on regular unleaded gasoline. Include the following emission control system(s): EM, TWC (if so equipped). include any user adjustable features - therefore no other adjustments are needed.

The two cycle engine used on this snow thrower requires a mixture of gasoline and oil for lubrication of the bearings and other moving parts. The correct fuel mixture ratio is 40:1 (3.2 oz. oil per gallon of gas - see Fuel Mixture Chart). Gasoline and oil must be pre-mixed in a clean gasoline container. Always use fresh, clean, unleaded gasoline.

FUEL MIX CHART (Mixture 40:1)

U. S.		IMPERIAL		S. I. (METRIC)	
GAS	OIL	GAS	OIL	GAS	OIL
1 Gal.	3.2 oz.	1 Gal.	3.7 oz.	4 Liters	100ML

GASOLINE AND OIL MIXTURE

Mix gasoline and oil as follows:

DO NOT FILL THE FUEL TANK WITH GASOLINE THAT DOES NOT HAVE OIL MIXED IN IT. SHAKE THE GASOLINE CONTAINER BEFORE EACH FILLING OF THE FUEL TANK.

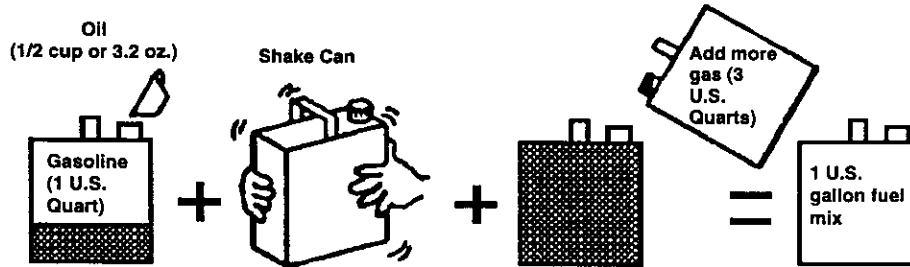

1 U.S. gallon container

- Pour 1 U.S. quart of fresh, clean, unleaded automotive gasoline to a gallon gasoline container.
- Add 3.2 oz of clean, high quality, Craftsman two-cycle oil into the gasoline container (One 3.2 ounces of oil provided).

IMPORTANT: Do not use outboard motor oil or automobile oils, such as SAE 30 oil, or multi-viscosity oils, such as 10W-30 or 10W-40.

- Reinstall the cap on the gasoline container and shake container vigorously so the oil mixes with the gasoline
- Add an additional 3 U.S. quarts of gasoline to the gallon container and shake the container again.

WARNING: Gasoline is flammable and caution must be used when handling or storing it. Do not fill fuel tank while snow thrower is running, hot, or when snow thrower is in an enclosed area. Keep away from open flame, electrical spark, and do not smoke while filling the fuel tank. Never fill fuel tank completely; but fill the tank to within 1/4-1/2 inch from the top to provide space for expansion of fuel. Always fill fuel tank outdoors and use a funnel or spout to prevent spilling. Make sure to wipe up any spilled fuel before starting the engine. Store gasoline in a clean, approved container, and keep the cap in place on the container. Keep gasoline in a cool, well ventilated place; never in the house. Never buy more than a 30 day supply of gasoline to ensure volatility. Gasoline is intended to be used as a fuel for internal combustion engines; therefore, do not use gasoline for any other purpose. Since many children like the smell of gasoline, keep it out of their reach because the fumes are dangerous to inhale, as well as being explosive.

TO STOP ENGINE

- To stop the engine, turn the key to OFF and remove key. Keep key in a safe place. The engine will not start without the key. See figure on next page.

TO START ENGINE (ELECTRIC START)

The snow thrower engine is equipped with a 120 volt AC electric starter and recoil starter. Before starting the engine, be certain that you have read the following information:

COLD START

- Insert the key and turn ON.
- Move the choke control to the FULL position.
- Connect the power cord to the switch box on the snow thrower.
- Plug the other end of the power cord into a three hole, grounded 120 volt AC receptacle.
- Push the primer button while covering the vent holes as follows: (Remove finger from primer button between primes).
Do not prime if temperature is above 50°F.

Two times if temperature is 50° F to 15°F.
Four times if temperature is below 15°F.

- Push down on the starter button until the engine starts. Do not crank for more than 20 seconds at a time. This electric starter is not thermally protected. Allow starter to cool off for 10 minutes before starting again or electric starter damaged can occur.
- Disconnect the power cord from the receptacle first and then from the switch box on the snow thrower.
- When the engine starts, release the starter button and move choke lever to

"1/2 choke" position. When engine runs smoothly, move choke lever to "No Choke" Position.

NOTE: Allow the engine to warm up for several minutes before blowing snow in temperatures below 0°F.

WARM START

- Be sure the choke is in the OFF position and pull the starter handle until the engine starts.
- Do not prime a warm engine. If the engine fails to start, follow the Cold Engine Start instructions on page 8.

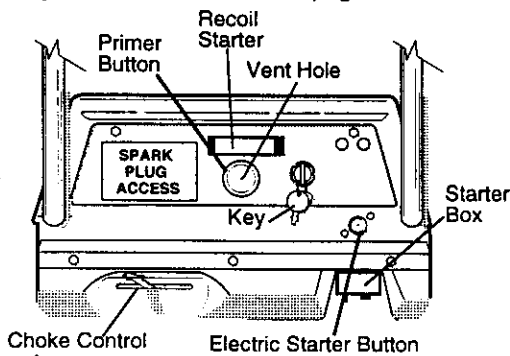

CAUTION: This starter is equipped to operate on 120 volt AC household current. Follow all instructions carefully as set forth in the "To Start Engine" section. When connecting 120 volt AC power cord, always connect the cord to the switch box on the engine first, then plug the other end into the household receptacle. When disconnecting the 120 volt AC power cord, always unplug from the household receptacle first.

TO STOP ENGINE

- To stop the engine, turn the key to OFF and remove key. Keep key in a safe place. The engine will not start without the key. See figure above.

TO START ENGINE (RECOIL START)

Before starting the engine, be certain that you have read and understood all the instructions on the preceding pages.

COLD START

- Insert the key and turn ON.
- Move the choke control to the FULL position.
- Push the primer button while covering the

vent holes as follows: (Remove finger from primer button between primes).

Do not prime if temperature is above 50°F.

Two times if temperature is 50° F to 15°F.

Four times if temperature is below 15°F.

- Pull the starter handle with a smooth rapid movement. Do not allow the starter rope to snap back. Rewind smoothly while holding the starter handle. If the engine fires but does not start, pull the starter handle until the engine starts.
- After three pulls, repeat the priming and pulling steps again.
- As engine starts warms up move choke lever to "1/2 choke" position. When engine runs smoothly, move choke lever to "No Choke" Position .

NOTE: Allow the engine to warm up for several minutes before blowing snow in temperatures below 0°F.

WARM START

- Do not prime a warm engine. If the engine fails to start, follow the Cold Engine Start instructions on this page.

CAUTION: Never run engine indoors or in enclosed, poorly ventilated areas. Engine exhaust contains carbon monoxide, an odorless and a deadly gas. Always stand behind snow thrower(operator's position) when starting engine. Do not put hands, feet, hair or loose clothing in or near the discharge chute deflector or auger housing while the engine is running. The temperature of the muffler and neaby areas may exceed 150° F.; avoid these areas also.

WARNING: Objects such as gravel, rocks or other debris, if struck by the auger, may be thrown with sufficient force to cause personal injury or property damage.

We recommend standard safety glasses or Wide Vision Safety Mask for over your glasses.

SNOW THROWING TIPS

- This snow thrower will propel itself forward when the handle is raised enough to cause the auger blades to contact the ground. The auger should stop when auger control bar is released. If it does not, refer to Adjust Auger Control Cable paragraph on page 12.
- For most efficient snow throwing, turn the discharge chute deflector to throw snow downwind, and slightly overlap each swath. In light snow take up to a full cut and in heavy snow take less than a full cut.
- The distance snow will be discharged can be adjusted by moving the discharge chute deflector. Raise the deflector for more distance or lower the deflector for less distance.
- In windy conditions, lower the chute deflector to direct discharged snow close to the ground where it is less likely to blow into unwanted areas.
- Keep the area to be cleared free of stones, toys and other foreign objects for safety and to prevent damage to the snow thrower.
- Do not use the auger propelling feature when clearing gravel or crushed rock driveways. Move the handle down to raise the auger slightly.
- The allowable forward speed of the snow thrower is dependent on the depth and weight of the snow. Experience will establish the most effective method of using the snow thrower under different conditions.

DRY AND AVERAGE SNOW

- Snow up to eight inch depth can be removed rapidly and easily by walking at a moderate rate. For snow or drifts of a greater depth you may find it desirable to slow your pace to allow the discharge chute to dispose of the snow as rapidly as the auger receives the snow.
- Plan to have the snow discharged in the direction the wind is blowing.

WET PACKED SNOW

- Move slowly into snow of this condition. The greater the depth, the slower you should go. When it appears that the wet, packed snow is causing the auger to slow down and the chute to clog, back off and begin a series of short jabs into the snow. These short back and forth, 4 to 6 inch, jabbing motions will "belch" the snow from the chute.

SNOW BANKS AND DRIFTS

- In snow of greater depth than the unit, use the jabbing technique described above. Turn the discharge chute away from the snow bank. More time will be required to remove snow of this type than level snow.

PRODUCT SPECIFICATIONS

HORSE POWER:	5HP
DISPLACEMENT:	8.46 cu. in.
GASOLINE CAPACITY:	1.62 quart (unleaded)
FUEL/OIL MIX RATIO:	40:1 (3.2 oz. of air-cooled engine 2 cycle oil specified for 40:1 per 1 gal. of gas)
SPARK PLUG:	Champion RCJ8Y (Gap .030) or Equivalent

MAINTENANCE

CUSTOMER RESPONSIBILITIES

SERVICE RECORDS	SCHEDULE					SERVICE DATES				
	Before Each Use	After first 12 Hours	As Needed	Before Storage	Begin Each Season					
Fill in dates as you complete regular service										
Tighten All Screws & Nuts		✓	✓							
Check Spark Plug					✓					
Check Drive Belts					✓					
Lubricate Chute Control Flange				✓						
Check Fuel	✓									
Drain Fuel				✓						

GENERAL RECOMMENDATIONS

The warranty on this snow thrower does not cover items that have been subjected to operator abuse or negligence. To receive full value from the warranty, the operator must maintain the snow thrower as instructed in this manual. The above chart is provided to assist the operator in properly maintaining the snow thrower.

SNOW THROWER AFTER FIRST USE

- Check for any loose or damaged parts after each use.
- Tighten any loose fasteners.

AFTER EACH USE

- Run the machine to clear the auger of snow.
- Remove all snow and slush from the snow thrower to prevent freezing of auger or controls.

LUBRICATION - AS REQUIRED

- Lubricate the flange on the discharge chute before storage. See To Remove Top Cover instructions on page 12.
- See Lubrication Chart diagram for lubrication points and type of lubricant.

LUBRICATION CHART

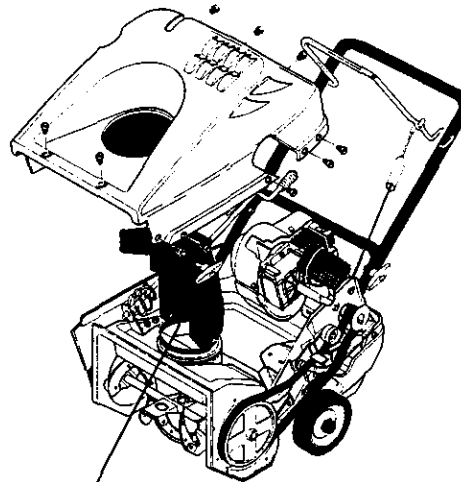

Lubricate chute control flange. Coat flange with a clinging type grease such as Lubriplate.

ENGINE

SPARK PLUG

- Clean the spark plug and reset the gap periodically. To service or replace spark plug, see To Replace the Spark Plug paragraph on page 15.
- Make sure that the spark plug is tightened securely into the engine and the spark plug wire is attached to the spark plug.
- If a torque wrench is available, torque plug to 18 to 23 foot pounds.
- Clean the area around the spark plug base before removal to prevent dirt from entering the engine.

SERVICE AND ADJUSTMENTS

CARBURETOR ADJUSTMENT

The carburetor on this snow thrower is not adjustable.

IMPORTANT: If you think the carburetor is not operating properly, contact your nearest Sears service center.

⚠ CAUTION: Never tamper with the engine governor which is factory set for proper engine speed. Over speeding the engine may increase the danger of personal injury and will void the engine warranty. If you think the engine governor high speed needs adjusting, contact your nearest Sears service center who has the proper equipment and experience to make any unnecessary adjustments.

TO ADJUST THE CHUTE CRANK ASSEMBLY

If you cannot rotate the chute crank fully to the left and to the right, you need to adjust the chute crank. See first figure on this page.

- Remove the top cover. See To Remove Top Cover instructions on this page.
- Loosen both 1/2" nuts on the crank adjusting bracket using 1/2" wrenches.
- Swivel the crank adjusting bracket to allow about 1/8" clearance between the notch in the flange and the outer diameter of the worm.
- Once this clearance is set, tighten the nuts.

TO ADJUST THE AUGER CONTROL CABLE

The auger control cable is set at the factory for proper operation. If you need to adjust the cable, because the control bar does not properly engage or disengage the auger, do the following:

- Remove "Z" hook from the auger control bar. See second figure on this page.
- Slide the boot toward the loose end of the cable. See last figure on this page.
- Push the cable down through the hole in the top of the cable adjustment bracket to provide slack in the cable. See last figure on this page.
- Remove the "Z" hook from the top hole in

the cable adjustment bracket and move to the next hole away from the top of the bracket. See last figure on this page.

- Pull cable slack through cable adjustment bracket and insert in the control bar. See last figure on this page.
- Replace boot over cable adjustment bracket.
- Insert "Z" hook in the auger control bar.
- Start the snow thrower and check that the auger does not continue to turn when the auger control bar is released.

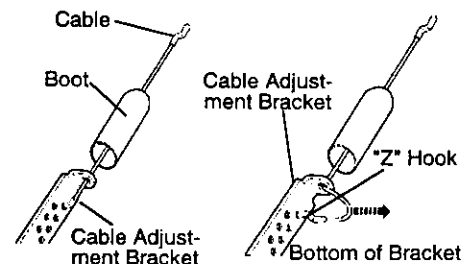
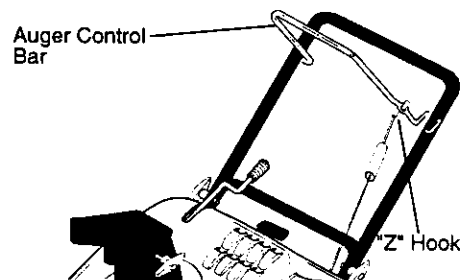
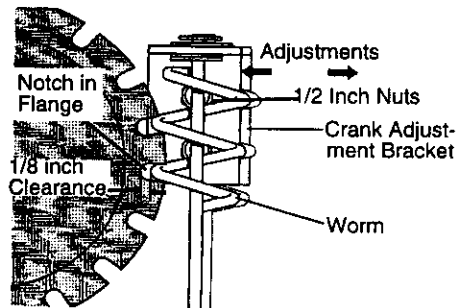

TO REMOVE TOP COVER

- Follow these steps from operator's position.
- Remove the T-knob and fasteners on the discharge chute.

- Remove the gas cap.
- Remove the two bolts and nuts from the front lip of the top cover. Use a flat head screwdriver and a 3/8" wrench.
- Remove the bolt from the front right side. Use a 5/16" and 3/8" wrench.
- Remove the four screws on the left side of the top cover. Use a large flat head screwdriver.
- Remove the bolt from the front left side. Use a 5/16" and 3/8" wrench.
- Remove the four screws on the right side of the top cover. Use a large flat head screwdriver.
- Remove the three screws from the top portion of the control panel. Use a large flat head screwdriver.
- Carefully pull up on the rear of top cover making sure to clear gas tank.
- Carefully lift top cover over the three bolts holding the lower chute to the chute ring.
NOTE: This area was designed to have a tight fit, it will be necessary to rock top cover carefully over these bolts.
- Remove top cover.
- Reinstall in reverse order.

TO REMOVE BELT COVER

- Follow these steps from operator's position. See figure on this page.
- Remove the four bolts and nuts holding the belt cover to the auger housing. Use a 5/16" and 3/8" wrench.
- Remove the two screws holding the belt cover to the top cover. Use a large flat head screwdriver. **NOTE:** If the top cover is already removed, omit this step.
- Remove the one screw holding the belt cover to the bottom cover. Use a large flat head screwdriver.
- Grasp the bottom portion of the belt cover and pull down and out to remove.
- Reinstall in reverse order.

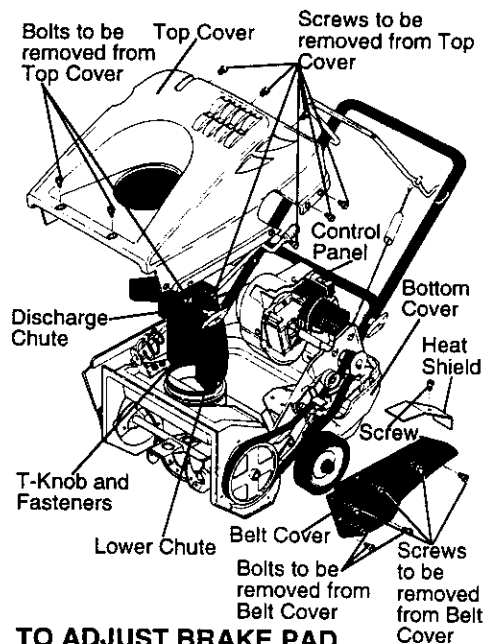

TO ADJUST BRAKE PAD

The brake pad is adjusted at the factory and no periodic adjustment is necessary.

IMPORTANT: Adjustment should only be made to the brake if the brake pad has become loose or has been removed. To adjust proceed as follows:

NOTE: See figure on next page for proper location of brake pad.

- Turn engine off.
- Remove belt cover. See To Remove Belt Cover paragraph on this page.
- Remove the top cover. See To Remove Top Cover instructions on page 12.

NOTE: Make sure the belt is in proper position. See To Replace the Drive Belt paragraph on page 14.

- Tie the control bail to the upper handle with a piece of string. **NOTE:** This will engage the pulley and belt system.
- Using a 7/16 wrench, 7/16 socket, and a ratchet loosen screw and nut on brake pad. See first figure on page 14 for location of screw and nut.
- Adjust brake pad up or down to have a 1/8" gap between the bottom of the brake pad and the belt.
- Tighten screw and nut.

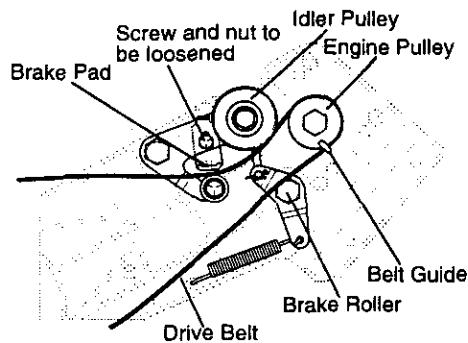

TO REPLACE THE DRIVE BELT

The drive belt on this unit is of special construction and must be replaced with the same type belt available at your nearest Craftsman Service Center.

- Remove the belt cover. See to Remove the Belt Cover paragraph on page 13.
- Move belt guide away from belt. See next figure. Belt may come out without loosening belt guide. Carefully press idler pulley down to release brake pressure on belt.

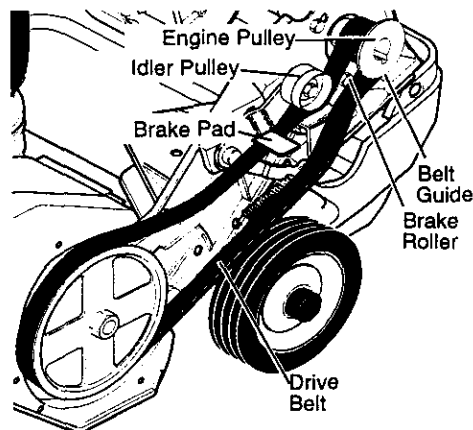

- Remove belt from between brake pad and roller.
- Remove old belt.
- Replace with new belt by carefully pressing down on the idler pulley and placing the belt between the brake pad and roller with belt ribs down.
- Release belt pulley.
- Attach new belt to the engine pulley and auger pulley.
- Make sure the belt is seated properly.

- Move belt guide into position. The belt guide should be $\frac{3}{32}$ " from belt when belt is engaged as shown in next figure.
- Reinstall belt cover.

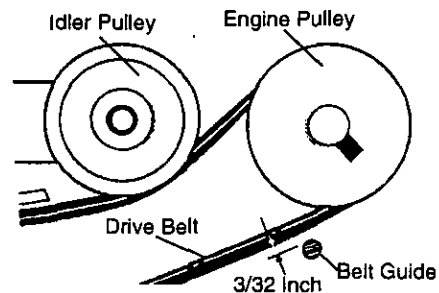

TO REPLACE THE AUGER

- Remove the belt cover, see To Remove Belt Cover paragraph on page 13 and the drive belt. See the Drive Belt Replacement paragraph on page 14.
- Remove the auger pulley, see figure below from the auger shaft (threads are left hand; turn clockwise to remove). Place a piece of wood (2x4) on the center paddle area to secure auger to keep from turning.
- Remove the bearing assembly from the left frame of snow thrower by removing the two nuts. See figure below.

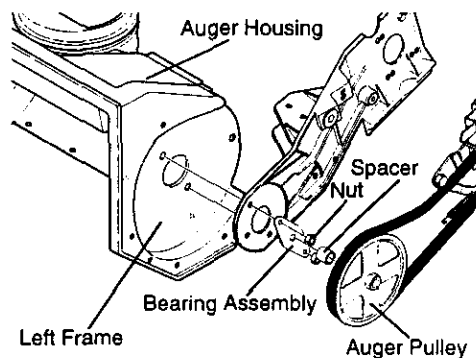

- Slide the auger assembly out of the bearing assembly on the right side of the snow thrower.
- Tip the auger assembly enough to allow it to slide out of the auger housing.
- Install the new auger assembly in reverse order of removal.

TO REPLACE THE SPARK PLUG

NOTICE: This spark ignition system meets all requirements of the Canadian Interference-Causing Equipment Regulations.

NOTICE: This engine complies with all current Australian and New Zealand limitations regarding electromagnetic interference.

The spark plug is housed in the engine compartment under the top cover and cannot be seen under normal conditions.

TO REMOVE BOTTOM COVER

- Remove black plastic spark plug access cover by squeezing the sides and pulling cover away. See figure below.
- The spark plug and wire are now visible.

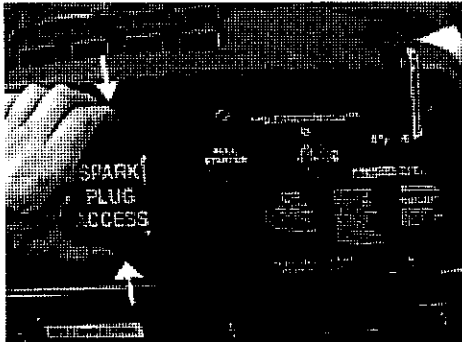

- Remove the spark plug wire.
- Clean the area around the plug base to prevent dirt from entering the engine when the plug is removed.
- Remove the spark plug. If it is cracked, fouled or dirty, it must be replaced. See page 10 for the proper replacement plug.
- Set the gap between the electrodes of the new spark plug at .030 inch. Next, install the spark plug in the cylinder head.

Torque plug to 18 to 20 ft. lb. If you do not use a torque wrench, tighten the plug firmly (See figure below).

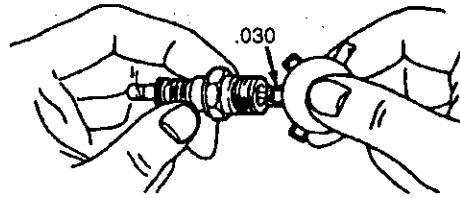

- Push the spark plug wire onto the spark plug.
- Reinstall the access panel.

ENGINE SERVICE

Unless the operator is fully qualified to make engine repairs or adjustments, we recommend that such work should be done by technicians trained to work on snow thrower type engines. Take your snow thrower to your nearest Craftsman Service Center for repair and adjustment.

ADJUST ENGINE SPEED

Your engine speed has been factory set. Do not attempt to change engine speed or it may result in personal injury. If you believe that the engine is running too fast or too slow, take your snow thrower to your nearest Craftsman Service Center for repair and adjustment.

STORAGE

⚠ WARNING: Never store your snow thrower indoors or in an enclosed, poorly ventilated area. If gasoline remains in the tank, fumes may reach an open flame, spark or pilot light from a furnace, water heater, clothes dryer, cigarette, etc.

To prevent engine damage (if snow thrower is not used for more than 30 days) follow the steps below.

SNOW THROWER STORAGE

- Thoroughly clean the snow thrower.
- Lubricate all the lubrication points. See the **Maintenance** section, page 11.
- Be sure that all nuts, bolts and screws are securely fastened. Inspect all visible moving parts for damage, breakage and wear. Replace if necessary.
- Touch up all rusted or chipped paint surfaces; sand lightly before painting.
- Cover the bare metal parts of the blower housing and auger with rust preventative, such as a spray lubricant.

ENGINE STORAGE

Gasoline must be removed or treated to prevent gum deposits from forming in the tank, filter, hose, and carburetor during storage. Also during storage, alcohol blended gasoline that uses ethanol or methanol (sometimes called gasohol) attracts water. It acts on the gasoline to form acids which damage the engine.

- Remove bottom cover. See first step in To Replace Spark Plug paragraph on page 15.
- To remove gasoline, run the engine until the tank is empty and the engine stops. Then drain remaining gasoline from carburetor by pressing upward on bowl drain located on the bottom of carburetor. See next figure.
- If you do not want to remove gasoline, a fuel stabilizer (such as Craftsman fuel stabilizer No. 33500) may be added to any gasoline left in the tank to minimize gum deposits and acids. If the tank is almost empty, mix stabilizer with fresh gasoline in a separate container and add some to the tank. Always follow instructions on stabilizer container. Instructions

on stabilizer container. Then run engine at least 10 minutes after stabilizer is added to allow mixture to reach carburetor. Store snow thrower in a safe place. See Warning under STORAGE.

OTHER

- If possible, store your snow thrower indoors with the gas removed and cover it to give protection from dust and dirt.
- If the machine must be stored outdoors, block up the snow thrower to be sure the entire machine is off the ground.
- Cover the snow thrower with a suitable protective cover that does not retain moisture. Do not use plastic or vinyl.

NOTE: A yearly checkup or tune-up at a Craftsman Service Center is a good way of ensuring that your snow thrower will provide maximum performance for the next season.

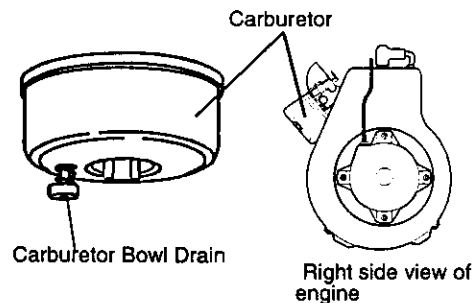

TROUBLE SHOOTING

TROUBLE	CAUSE	CORRECTION
Difficult starting	Defective spark plug	Replace defective plug
Engine stalls	Unit running on CHOKE	Move choke lever to OFF position
Engine runs erratically or Loss of power	Blocked fuel line or low on fuel Water or dirt in fuel system	Clean fuel line; check fuel supply; add fresh gasoline (gasoline/oil mixture if 2-cycle engine) Use carburetor bowl drain to flush and refill with fresh fuel
Excessive vibration	Loose parts; damaged impeller Damaged auger	Stop engine immediately and remove key. Tighten all bolts and make all necessary repairs. If vibration continues, have the unit serviced by a Craftsman service repairman Repair or replace auger assembly
Units fails to propel itself	Drive belt loose or damaged Incorrect adjustment of auger control cable	Replace drive belt Adjust auger control cable
Unit fails to discharge snow	Auger drive belt loose or damaged Auger control cable not adjusted correctly Discharge chute clogged Foreign object lodged in auger	Adjust auger drive belt; replace if damaged Adjust auger control cable Stop engine immediately and remove key. Clean discharge chute and inside of auger housing Stop engine immediately and remove key. Remove object from auger.