

AEKE

S1 Series Smart HomeGym
User Manual

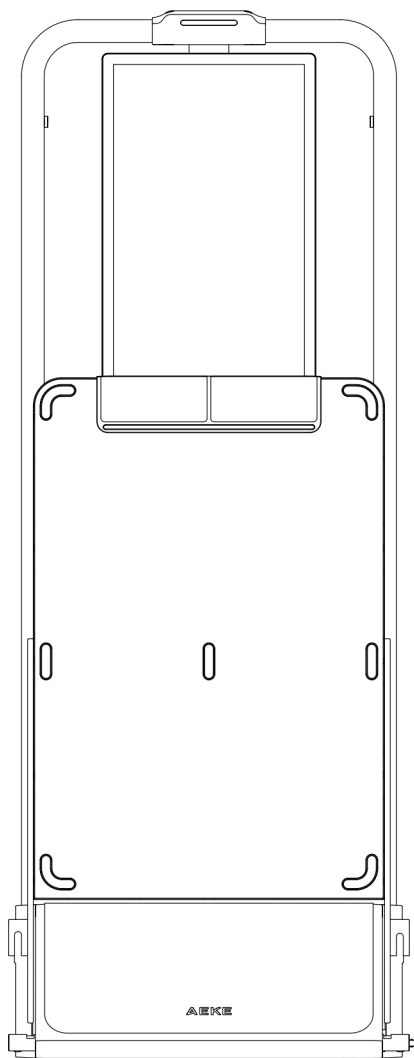

WELCOME TO AEKE

Individual code number: 91440300MA5HDDFB3Q
Thankyou for choosing the S1 Series Smart Home Gym.
Before using the product, please read the product
information and precautions provided in this manual

How to get support?

We are here to help whenever you need us. You can
contact us in the following ways:

 **WEBSITE:** www.aeke.com

 **EMAIL:** support@aeke.com

DISCLAIMER

Qudong Future (Shenzhen) Technology Co., Ltd., hereinafter referred to as "the Company," and the S1 Series Smart Home Gym and its related accessories, hereinafter referred to as "the Product."

To protect your legal rights, please carefully read this manual and its disclaimer before using the Product. You are required to use the Product strictly in accordance with the instructions provided herein. By activating and using the Product, you are deemed to have read, understood, acknowledged, and accepted all terms and conditions of this manual and its disclaimer. Users undertake to be responsible for their own actions and all consequences arising therefrom. Users agree to use the Product solely for legitimate purposes and to comply with any current or future policies or guidelines established by the Company.

During the use and maintenance of the Product, you must strictly adhere to and follow all requirements outlined in this manual, including but not limited to its instructions. The Company shall not be liable for any personal injury, accidents, property damage, legal disputes, or other adverse events resulting in conflicts of interest caused by failure to follow these instructions or due to unforeseeable circumstances beyond our control. The Company shall not bear any responsibility for any actions arising directly or indirectly from the use of the Product that violate applicable laws or regulations. Users shall assume full responsibility and liability for such incidents and losses. If any operation seems overly complex or unsafe, we recommend contacting our support team for professional guidance.

This device is "for consumer use only." The ownershall provide users with all necessary warnings and instructions.

CONTENTS

01 | Safety Information 01

02 | Product Overview

Product Diagram	06
Package Contents	09
Product Specifications	11

03 | Installation and Placement

Pre - Unpacking	12
Unpacking	13
Moving	14
Installing	15
Placement	16

04 | Product Operation

Power On/Off	18
Standby / Reset / Turning Off	18
Bluetooth Connection	19
Wi-Fi Setup	20

05 | Accessories Overview

Smart Grips View	21
Cross-bar & Resistance Controller	25
Triceps Rope View	27
Smart 8 Electrode scale	28
Heart Rate Armband	28
Camera cover	31

06	Troubleshooting	
	SN Lookup	32
	Resistance Cable Can Not Retract	32
	Technical Support	33

07	Maintenance and Care	
	Device Cleaning	34
	Screen Maintenance	34
	Power Maintenance	34
	Resistance Cable Replacement	34
	Prohibitions	34
	Precautions	35
	Permanent marker	36

08	Warranty and After-Sales Service	
	Overview	37
	Limited Product Warranty	37
	Free Repair Conditions	38
	Exclusions	38
	How to Get Service	38

09	Return and Refund policy	39
-----------	---------------------------------	----

10	FCC&CE Statement	41
-----------	-----------------------------	----



SAFETY INFORMATION.

01

Installation Safety



GROUND REQUIRED



ORIGINAL 3-PRONG POWER



KEEP AREA CLEAN

- Install the Product strictly according to this user manual.
- Use the original 3-prong power cord and connect only to a properly grounded outlet (\cong).
- Place the Product on a stable, level hard surface (e.g., marble, hardwood, or tile). Do not place it on soft surfaces such as carpet or felt.
- Keep the area around the Product clear of clutter, heavy objects, and items that could fall to prevent instability or damage to the mirrored screen.

Electrical Safety



NO FLAMMABLES



NO DAMP



NO OPEN FLAME

- The product is not waterproof and must be used in a dry, well-ventilated environment. Do not splash water on it, and prevent water from entering the power port, mirrored screen, or internal gaps between the frame to avoid short circuits or other damage.
- During severe weather conditions such as thunderstorms, unplug the power cord to prevent damage to the product.
- Use only power outlets certified for safety by national standards, and avoid overloading electrical circuits.

- use the original power cord provided with the product Do not use power equipment from other brands to power the product
- keep the product away from high electromagnetic interference environments, such as mobile phone base stations or high-power transmission devices, during use
- If you notice unusual noises, odors, smoke, or any other irregularities during use, immediately turn off the power, unplug the cord, and contact official customer service

Operational Safety

- Avoid striking , pressing , or applying external force to the touch screen Do not scratch or damage it, as this may cause it to crack or shatter
- Before using the product, wear appropriate workout clothing and shoes Avoid loose-fitting garments or any equipment, jewelry, or accessories that may pose a safety risk during exercise

Child and Pet Safety

- Minors should only use the product under the supervision and guidance of a guardian
- Position the product with its mirrored side facing a wall to avoid placement in pathways frequented by children or pets
- Prevent children or pets from climbing on the product, which could cause it to tip over
- Ensure children and pets do not play, chase, jump, or interact with the product in anyway that could lead to tipping or damage

Unsuitable Users



Please Consult a Doctor If You Fall Into the Following Categories Before Using This Product!

To ensure your safety, individuals with the following conditions or circumstances must consult a doctor to determine if this product is suitable for use:

- Are 65 years or older;
- Are pregnant or in the perinatal/postpartum period;
- Are under medical treatment and/or taking medication;
- Have any chronic illness or current/recent injury;
- Have cardiovascular/cerebrovascular conditions (e.g., hypertension, heart disease, stroke/cerebral infarction, insufficient cerebral blood supply);
- Have metabolic disorders (e.g., diabetes, hypoglycemia, gout);
- Have respiratory diseases (e.g., asthma);
- Have musculoskeletal/orthopedic conditions (e.g., muscle/ligament/myofascial injury, arthritis, joint or soft-tissue injury, connective tissue disease);
- Have coordination, neurological, or peripheral vascular disorders;
- Have limited legal capacity;
- Are under the influence of alcohol, fatigued, unwell, after high-intensity work, or with irregular sleep;
- Are in a poorly ventilated or high-temperature environment (risk of heatstroke).

Safety Precautions

- **Heart rate monitoring:** Wear the supplied heart rate armband. Keep intensity within a safe range. Avoid prolonged high-intensity exercise and overtraining.
- **Stop if symptoms occur:** Stop immediately if you feel chest tightness, dizziness, pain, shortness of breath, or any unusual symptoms. Seek medical attention. Consult a doctor before resuming.
- **Implanted medical devices:** If you have a pacemaker, defibrillator, or other implanted device, consult a doctor before use. The product may generate electromagnetic fields. If approved, keep a safe distance and follow guidance from your doctor/device manufacturer.
- **Suspected interference:** If you suspect interference with a medical device, stop using the product immediately.



PRODUCT OVERVIEW .

02

Product Diagram

- ① Footboard Release Pedal
- ② Hydraulic Soft-Lowering Footboard
- ③ Top Interaction Light

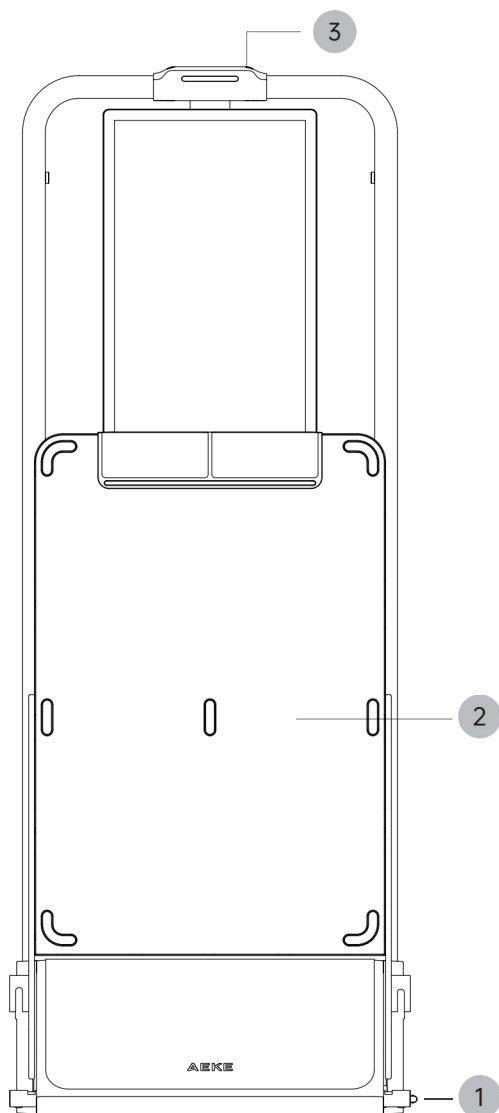

Front View (Folded)

Product Diagram

① Screen Power Button

② Footboard Lock Lever

③ 27-inch FHD Screen

④ AI Camera

⑤ Front Cover

⑥ Microphone voice

⑦ Footboard Release Pedal

⑧ Adjustable Arm

⑨ Adjustable Arm Horizontal Adjustment Button (H)

⑩ Adjustable Arm Vertical Adjustment Button (V)

⑪ Adjustable Arm Height Adjustment Pin (R/L)

⑫ Cord Buckle

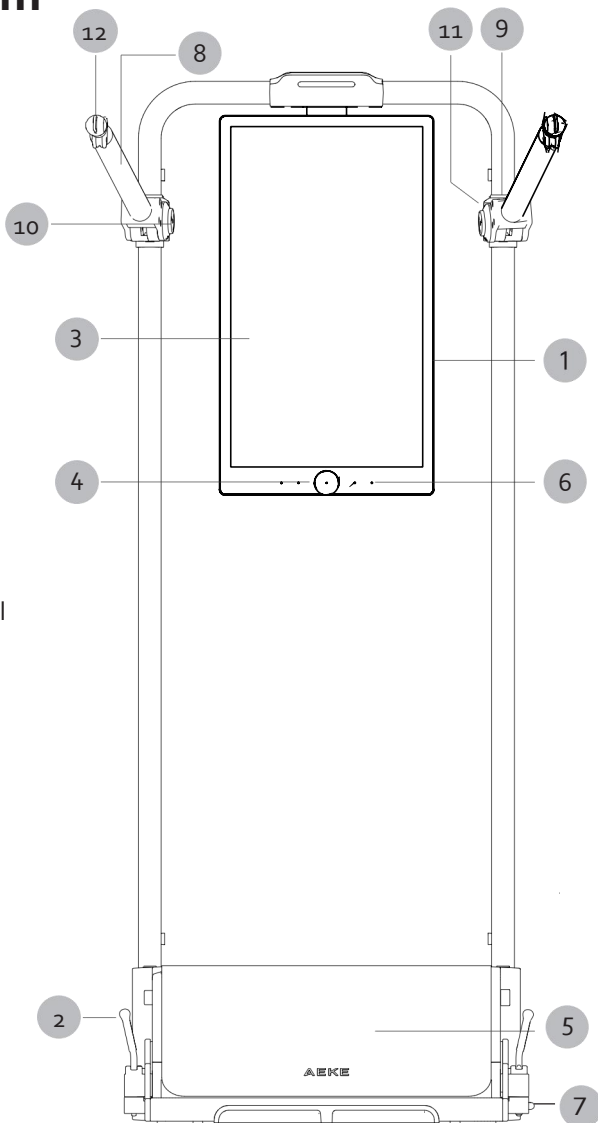

Product Diagram

- ① Screen Rotation Hinge
- ② Anti-Tip Wall Anchor Kit
- ③ Audio Cover Plate
- ④ Cooling Vent
- ⑤ USB Port
- ⑥ Power Switch
- ⑦ Caster Wheels
- ⑧ Adjustable Arm
Height Adjustment Pin (R/L)

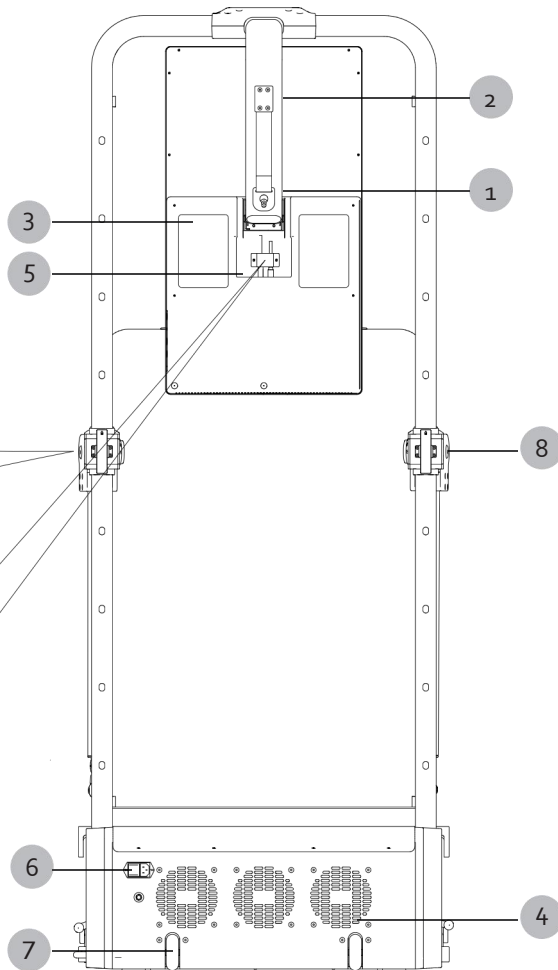
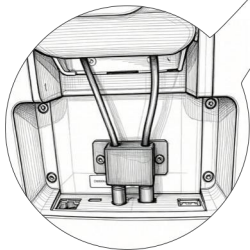
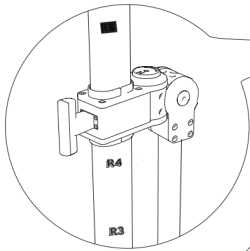

These ports all belong to the modulation ports of the product.

Package Contents

AEKE S1 Series Smart Home Gym

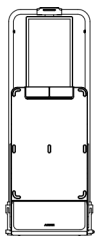

Smart Grips

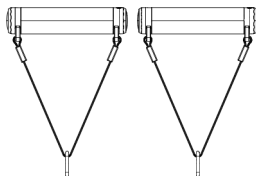

Crossbar

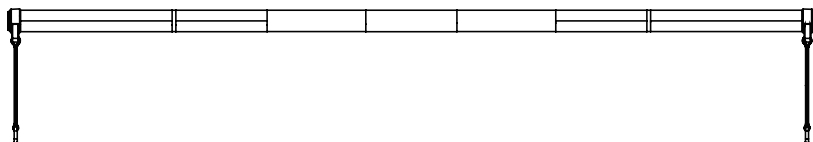

Ankle Strap

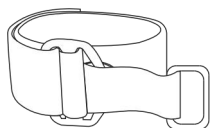

Smart 8 Electrode Scale

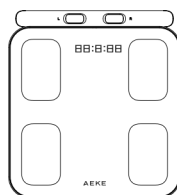

Triceps Rope

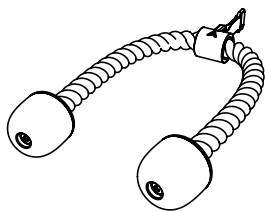

Resistance Controller

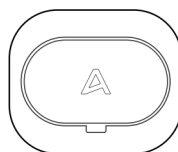

Package Contents

Heart Rate Armband



Camera Cover



Replacement Cable

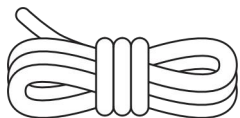

Heart Rate Armband Charger

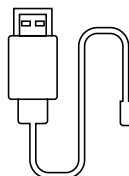

Power Cord

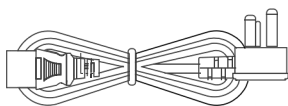

Product Specifications

Item	S1 Series Smart Home Gym
Model Number	SHG2501-1
Rated Power	1300 W
Rated Voltage	110–240 V, 50/60Hz
Connectivity	Wi-Fi (2.4G & 5.0G), Bluetooth 5.2
Net Weight	110 kg
Packaged Weight	130 kg
Wi-Fi Standard Protocol	IEEE 802.11a/b/g/n/ac/ax
Wi-Fi 2.4GHz	2400~2483.5MHz
Wi-Fi 5GHz	5150~5250MHz, 5725~5850MHz
The Wifi of Main PCBA Maximum Conductive Power of Wireless Transmitter	FCC Certification: WiFi 5G: 15 dbm WiFi 2.4G: 16dbm CE Certification: WiFi 5G: 15dbm WiFi 2.4G: 15dbm
The BLE of Left Adjustable Arm Maximum Conductive Power of Wireless Transmitter	FCC Certification: 3 dbm CE Certification: 4dbm
The BLE of Right Adjustable Arm Maximum Conductive Power of Wireless Transmitter	FCC Certification: 3 dbm CE Certification: 4 dbm
The BT of Right Adjustable Arm Maximum Conductive Power of Wireless Transmitter	FCC Certification: 2 dbm CE Certification: 4 dbm
Unfolded Dimensions	715 mm × 1355 mm × 1850 mm
Folded Dimensions	715 mm × 425 mm × 1850 mm
Package Dimensions	840 mm × 520 mm × 2000 mm
Operating Temperature	0°C to 45°C
Storage Temperature	-20°C to 60°C

Item	Smart Grips
Model Number	SHG2501-2
BLE	2402MHz-2480MHz
The BLE of Smart Grips Maximum Conductive Power of Wireless Transmitter	FCC Certification: -3dbm CE Certification: -1dbm
Operating Temperature	0°C to 45°C
Storage Temperature	-20°C to 60°C

Note:

- If your household operates on a 110–120V electrical system, AEKE recommends plugging the device into a 20-amp power outlet to ensure safer operation.
- If your household operates on a 200–240V electrical system, simply install the device in your designated space and adjust it as needed.



INSTALLATION AND PLACEMENT.

03

It is recommended that users retain the outer packaging for a period after unboxing for future use (such as after-sales service or returns)



Pre-Unpacking

- This product requires no drilling for installation-it's ready to use right out of the box Before use, remove all packaging materials, including the outer carton, foam protective shell , and any other coverings
- Ensure the product is placed on a flat, hard surface such as marble, hardwood, or ceramic tiles Do not place it on soft surfaces like carpets, rugs, or felt
- Make sure the area around the product is clear of clutter, heavy objects, items that may tip over, or anything that could affect its stability or damage the mirror screen
- position the product in a well-ventilated indoor area, away from heat sources, and avoid direct sunlight exposure
- Do not place the product in humid or wet areas to prevent rust or reduced insulation effectiveness

Unpacking

- ① Remove the plastic latches from top to bottom.
- ② Squeeze and remove the latches on both sides of the carton.
- ③ Open the carton and take out the scale and accessories box.
- ④ Remove the top cover and the upper foam protectors.
- ⑤ When shipped from the factory, the adjustable arm angle is set to R/L6, V₁, H₂
- ⑥ With two people, slightly tilt the unit and remove the bottom foam protectors (repeat on both sides).
- ⑦ Carefully tilt and move the unit to remove the bottom support base

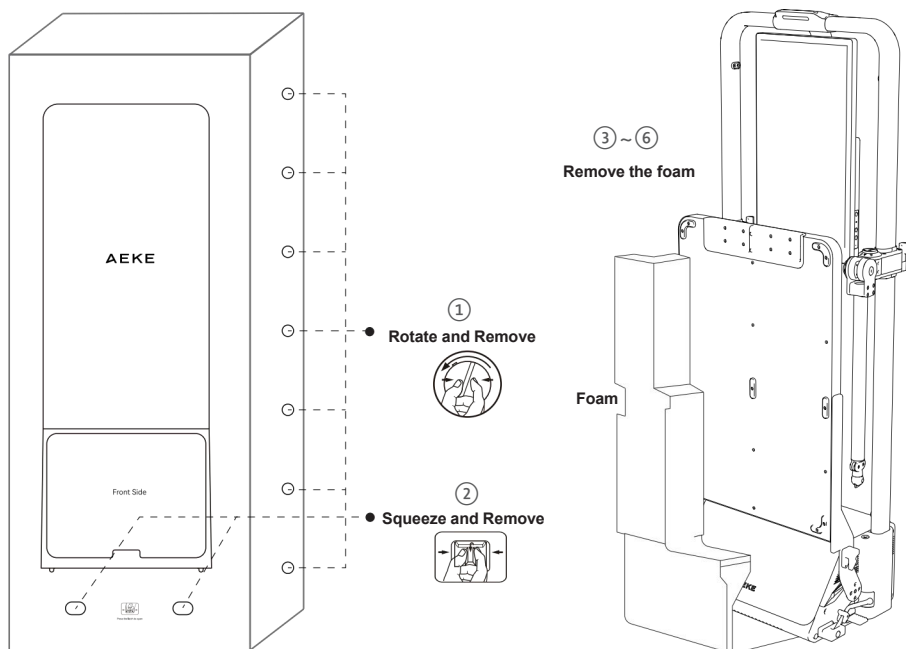

Moving

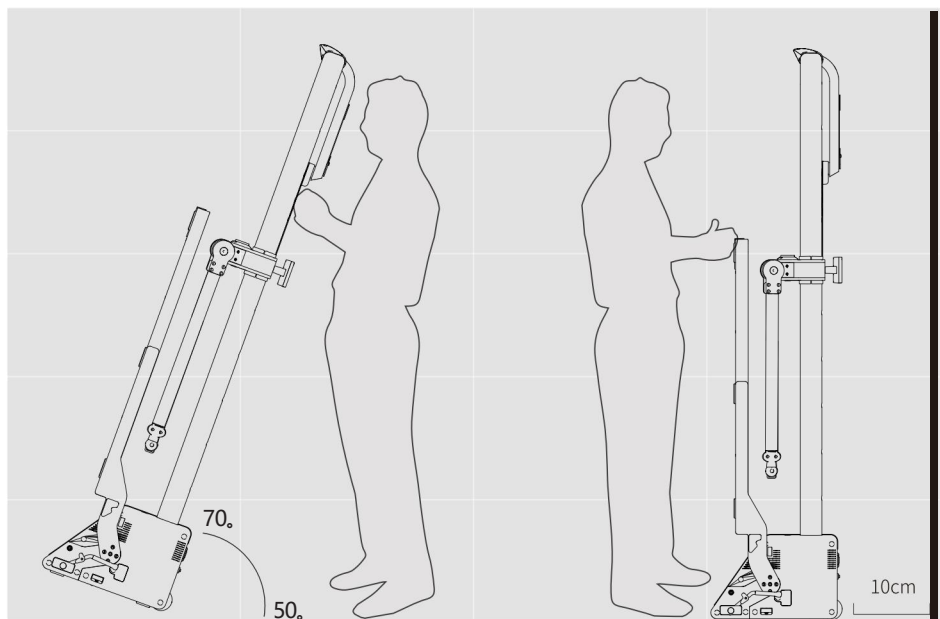

- Power off first. Before moving, turn off the unit and unplug the power cord and accessories.
- Maintain a safe tilt angle. Keep a safe tilt angle throughout the moving process to prevent the unit from tipping over.
- Moving method. Stand behind the unit. Firmly grip both sides of the frame with both hands, tilt the unit backward 50°–70° and pull it backward using the bottom moving wheels.
- Children shall not move the main unit. It is strictly prohibited for children to be within the device's range when unattended, to prevent injuries caused by product impact.



Installing

STEP 1: push & unlock



Push footboard inward and step on gray unlock pedal.

STEP 2: Lower slowly



Hold footboard lightly, allow it to lower slowly

STEP 3: Lock lever



Lock the footboard lever before you workout

Placement

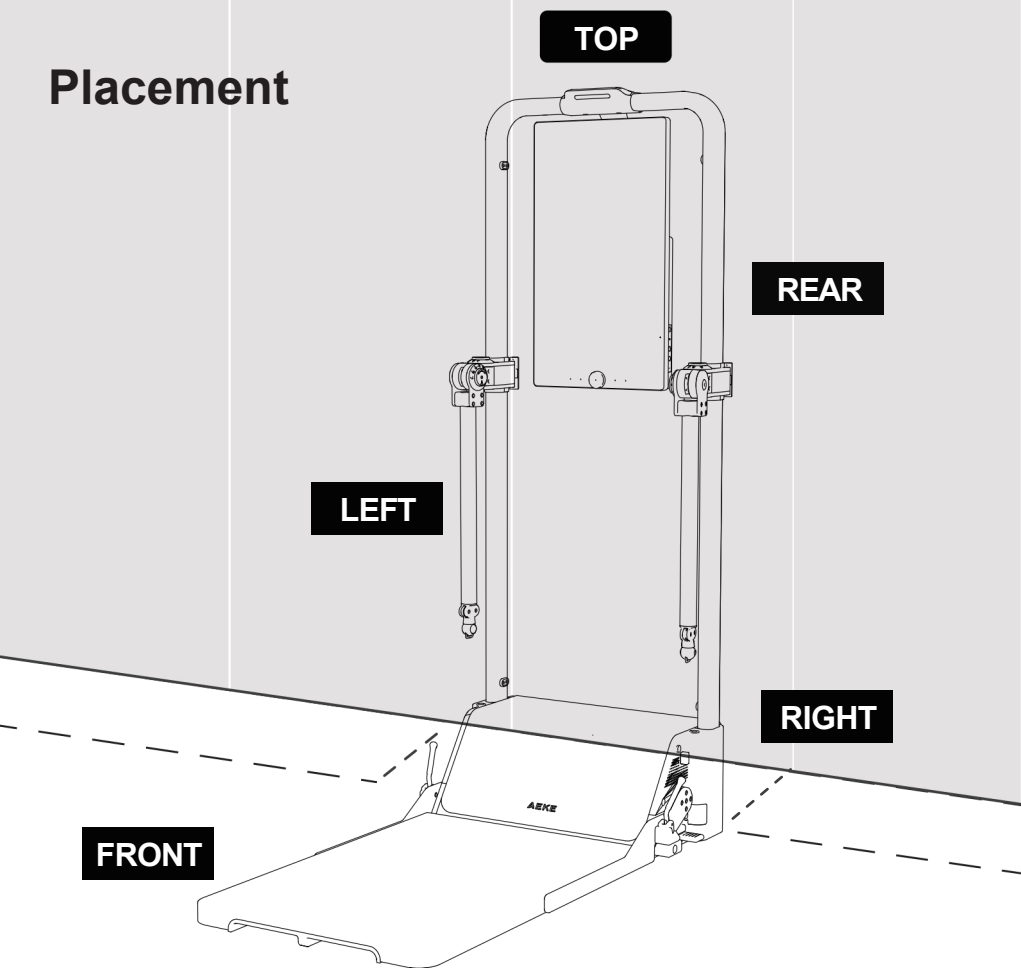

- Ensure the product is placed on a flat, hard surface (e.g., marble, solid wood, wood-like flooring, or tiles).
- The product must be positioned at least 10 cm away from the wall to avoid direct contact with the wall.
- Confirm the pedal Footboard is fully unfolded, then lock the pedal lock lever. Make sure it is secure before use.
- AEKE will not be responsible for any issues arising from failure to follow these placement requirements.

Precautions for Equipment Free Movement Area and Training Area:

- The free movement area should be at least 0.6 meters larger than the training area in the direction the equipment enters.
- The free movement area should include an emergency disembarkation area.
- When equipment is arranged adjacent to each other, the free space can be shared.



PRODUCT OPERATION .

04

Power On/Off

- After connecting the main unit to a power source, turn on the power switch located at the bottom of the back of the unit, then briefly press the Power On/Off Button on the side of the unit to power on.
- To power off, ensure the pedals are fully folded, the screen is off, and then turn off the main power switch.

The button of the unit

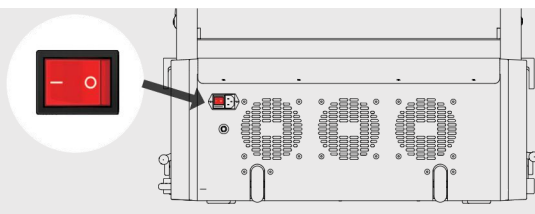

Standby / Reset / Turning Off

- Standby**
- Short press Power ($\leq 0.5s$): Screen off \rightarrow Standby
 - Short press Power ($\leq 0.5s$): Wake / Screen on
- Reset**
- Press and hold Power ($\geq 2s, < 5s$): Menu pops up \rightarrow select Restart
- Turning Off**
- Press and hold Power ($\geq 5s$): Force power off
- Sound**
- Volume + / -: Increase / decrease volume

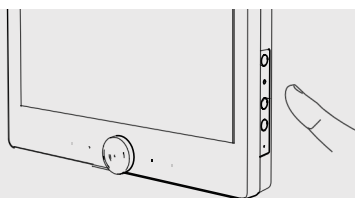

The right side of screen

Bluetooth Connection

- Scan the QR code on the screen to download the AEKE App, then complete the registration and login process.



- In the app, navigate to **[Home] > [S1 Series Smart Home Gym] > [Add New Device]**
 Follow the on - screen instructions to enable Bluetooth and location services on your phone, then proceed to the next step
- From the Bluetooth search results, select the current S1 Series Smart Home Gym to complete the connection

The path to the product training videos in the device is as follows:

- For first-time users, a pop-up window will automatically appear prompting: "Quickly learn how to use AEKE." After watching this, watch "Insert the Battery into the Pin," and finally "Lock the Footboard Lever."
- For registered users, from the Home screen, switch to the Lifestyle screen and find the User Guide section to view the product usage introduction videos.

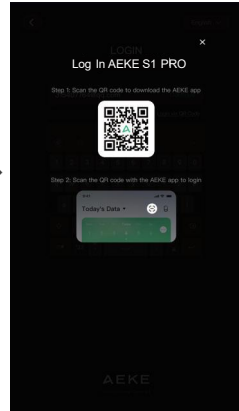
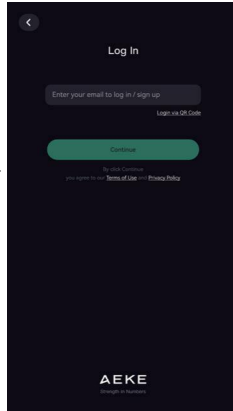
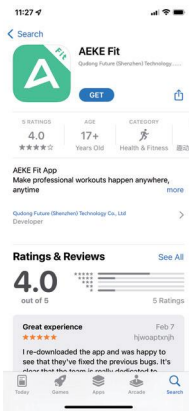

Wi-Fi Setup

1. Swipe down from the top of the mirror screen and select the [wi-Fi] icon

2. Choose the wi-Fi network and enter the password to connect

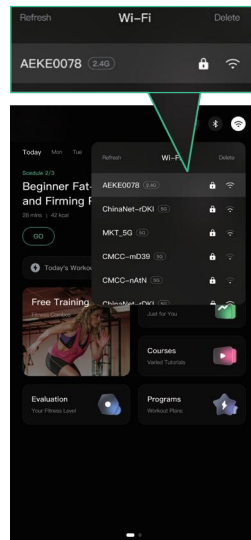
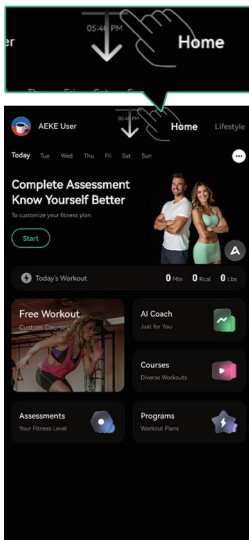

Usage and Adjustment



1. When using the device, users must follow the on-screen instructional prompts for practice exercises. Failure to adhere to these instructions may result in errors or excessive training, potentially causing health risks.

For example, improper use of hand exercises with incorrect components or techniques may easily lead to biceps brachii injuries.

Exercising the back without using the correct equipment and proper technique can easily lead to injuries such as scapular damage.



The product must be used correctly. Children must stay away from the device when unattended to avoid injury from collisions!

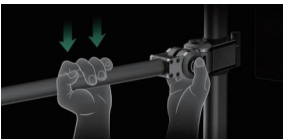

2.1 To adjust the vertical angle, simply press the V-shaped button with one hand while holding the adjustable arm with the other hand to select any of the 1–7 vertical angle settings.



2.2. To adjust the horizontal angle, simply press the H-shaped button with one hand while using the other hand to grip the adjustable arm, allowing adjustment across any of the 1–3 horizontal angle settings.



2.3. To adjust the gantry height, simply pull out the pin with one hand while lifting the adjustable arm with the other hand to select any of the 1–9 height settings.



ACCESSORIES OVERVIEW

05

Smart Grips View

Function Introduction:

- The Smart Grips quickly connects to the resistance cable, enabling a wide range of strength training exercises.
- During use, press the side release button to quickly release resistance.

Press

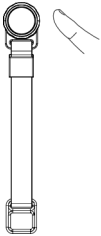

Light

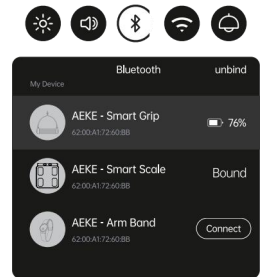
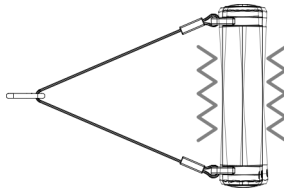

Bluetooth Connection:

- Pull down the S1 RPO Bluetooth toolbar to search for devices.
- Power on: Make sure the battery is sufficient, then press the button briefly until the grip turn on the light
- Tap the detected "Smart Grips" to connect.

Installation

- Press the button on the cord-lock.
- Insert the square buckle of the Smart Grips into the bayonet at the end of the pull cord.
- Release the button and confirm the Smart Grips is securely attached.

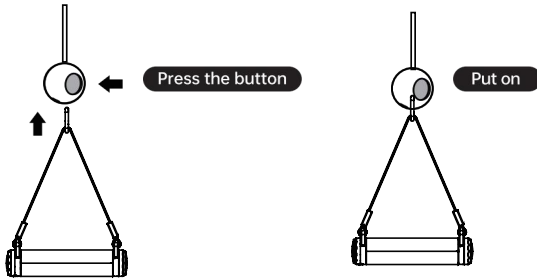

Detach

1. Press the button on the cord-lock.
2. Remove the Smart Grips from the bayonet to separate it.

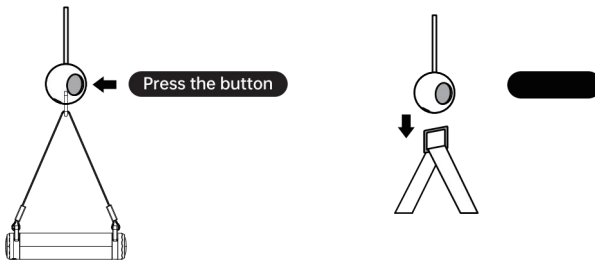

Battery replacement

- Press the release button on the end cap to unlock it.
- Pull out the end cap from the handle.
- Remove one battery from the battery compartment.
- Replace with a new battery, making sure the + / - polarity matches the markings.
- Reinsert the end cap and push until it clicks into place.

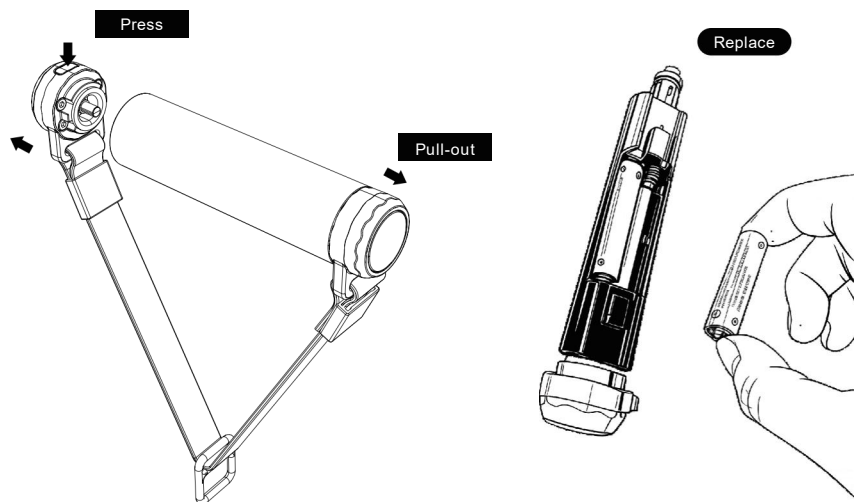

Maintenance and care

- This product is not waterproof; do not rinse directly with water or immerse it in water
- To clean, gently wipe with a damp towel and allow it to air dry naturally
- when not in use, store the Smart Grips in the designated storage compartment on the back of the main unit

Cross-Bar & Resistance Controller

Cross-bar

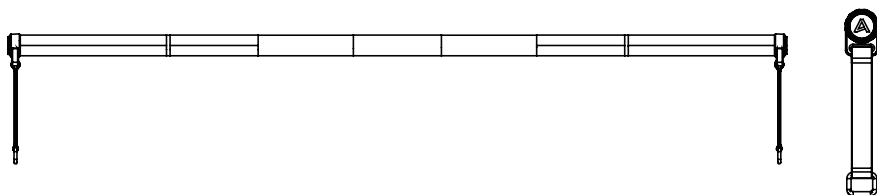

Function Introduction

- The Cross-Bar and Resistance Controller are designed to work together. They connect quickly to the pull cord to support a variety of strength training exercises.
- The Resistance Controller has a built-in Bluetooth module and connects to the main unit via Bluetooth.
- During use, lightly tap the Resistance Controller to quickly release resistance.

Bluetooth Connection

- Before first use, remove the insulating strip from the back of the Resistance Controller.
- Briefly press the Resistance Controller button. When the indicator light turns on, a pairing prompt will appear on the S1 RPO screen—tap to connect.
- After connection, check the Resistance Controller status in the S1 RPO Bluetooth toolbar.

05

ACCESSORIES OVERVIEW

Installation and Use

The Cross-Bar and Unloader must be used together. Before use, attach the two circular buckles to the Cross-Bar.

Secure the Unloader to a suitable position on the Cross-Bar and make sure it is firmly locked.

To remove the Unloader, press the release button to detach it.

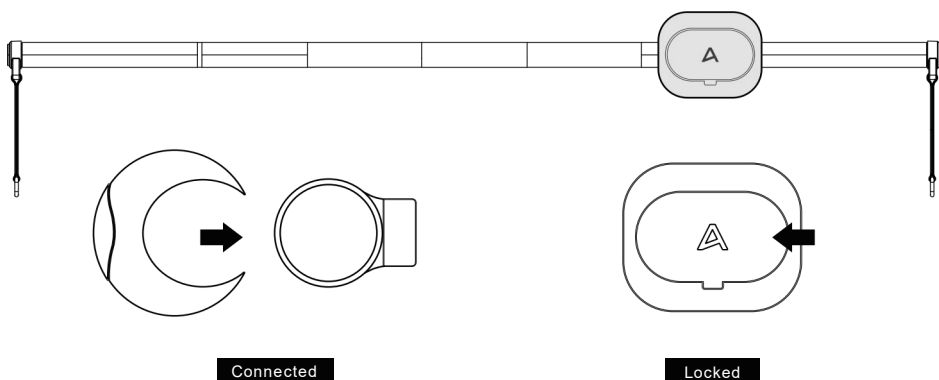

Charging Instructions

- The Resistance Controller uses a CR2032 button battery and does not support charging.
- When the Resistance Controller's battery is depleted, replace it. The initial battery life is approximately 3 months.

Maintenance and Care

- The Resistance Controller is not waterproof. Do not rinse with water or immerse it in water.
- Clean by gently wiping with a damp towel and allow it to air dry naturally.
- When not in use, store the Resistance Controller in the appropriate compartment on the back of the main unit.

Triceps Rope View

Function Introduction

- The Triceps Rope connects to the resistance pull cord to support a wide range of strength training exercises (e.g., pushdowns, rows, and crunches).
- It provides a comfortable grip and flexible range of motion for two-hand movements.

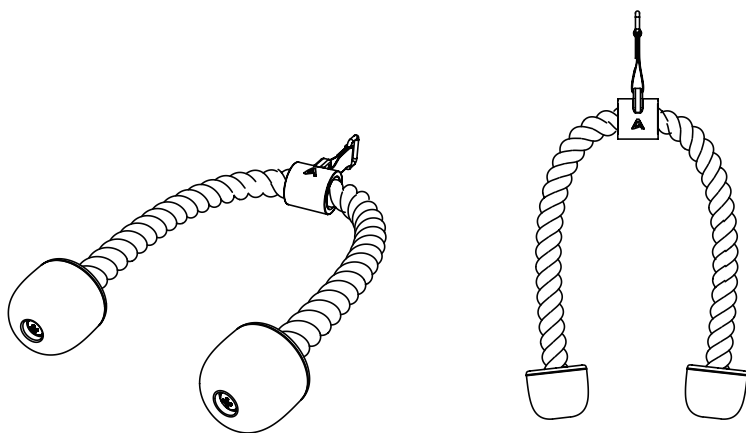

Installation and Use

- Press the button on the cord-lock.
- Insert the buckle/connector of the Triceps Rope into the bayonet at the end of the pull cord.
- Release the button and confirm the connection is secure before use.
- To detach, press the cord-lock button and remove the Triceps Rope.

05 ACCESSORIES OVERVIEW

Smart 8 Electrode Scale

- Refer to the Electrode Scale User Manual for details.

Heart Rate Armband

Front



Back

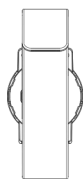

Side

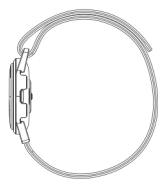

*This product is intended for fitness assistance only and cannot replace medical advice.

Indicator Light

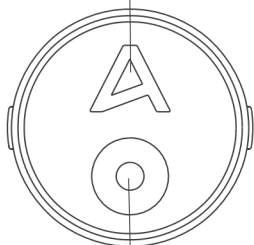

Power Button

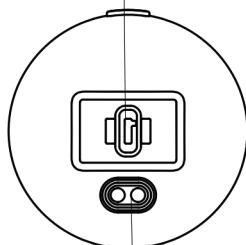

Charging Contacts

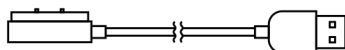

Function Introduction

- The sensor collects heart rate data once valid data is detected , the green light switches from fast flashing to slow flashing
- This product features an auto-shutdown function: if no heart rate data is detected for over 90 seconds, it powers off automatically
- The auto-shutdown function activates if no heart rate data is detected for over 90 seconds
-

Wearing Instructions

- Wear on the upper arm, close to the inner elbow.
- Heart rate displays within 15 seconds.

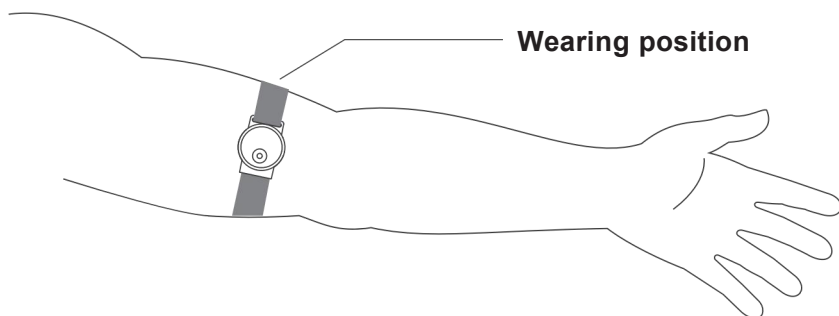

Bluetooth Connection

- Long-press the power button on the heart rate armband until the LED flashes green. Swipe down from the top of the mirror screen and select the [Bluetooth] icon.
- A connection window will appear on the screen; select the current [Heart Rate Armband] to connect.

Charging Instructions

- The device requires charging before first use.
- Use the provided charging cable with a DC 5V power adapter to charge the device.
- During charging, red and green lights flash alternately; when fully charged, the green light remains steady, indicating charging can stop.

Main Unit Assembly/Disassembly

Removing the Main Unit

Press the front of the main unit to remove it.

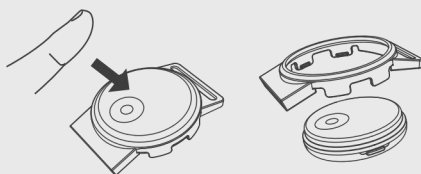

Installing the Main Unit

Align the protruding part of the main unit with the slot and snap it into place.

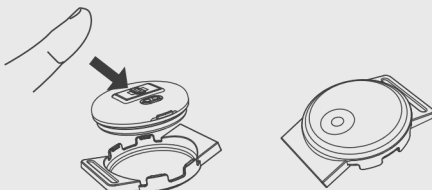

05 ACCESSORIES OVERVIEW

Camera Cover

Front

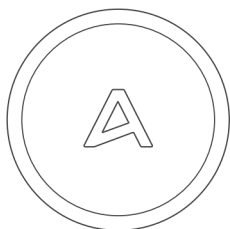

Side



Function Introduction

- The privacy cover has a built-in magnet and can be attached directly to the glass over the built-in camera on the screen to protect user privacy.

During exercise, remove the cover and attach it to the metal backplate of the main unit.

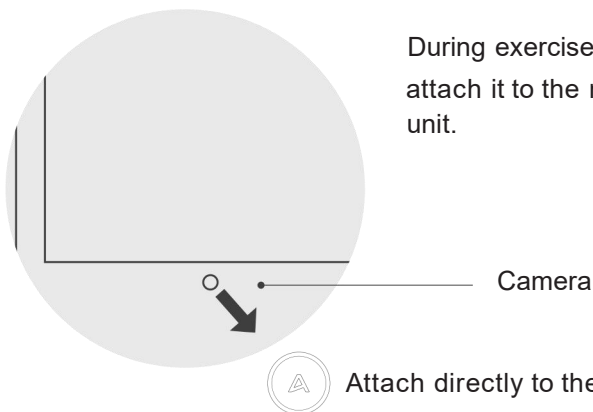



TROUBLESHOOTING .

06

SN Lookup

Before we can help identify the issue, please share the SN code with us.

- Method A: Check the label on the back of the machine button for the SN
- Method B: On the top-left of the interface, goto Settings → Device Info → SN
- Method C: In the AEKE App, goto Device → Device Info → SN

Profile > Settings > Device Info > DeviceSN

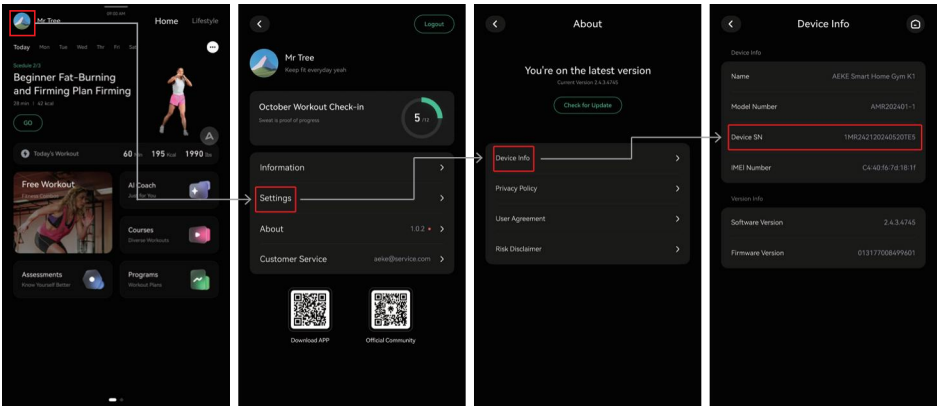

Resistance Cable Can Not Retract

- Tap the floating “A” icon in the upper-right corner of the screen.
- Click “Retracting” and wait for the cable to retract.
- If the issue is not resolved, turn off the main power, wait 30 seconds, then power it on again.

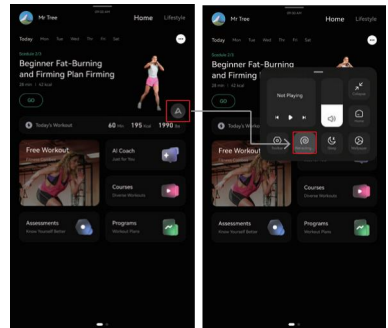

Body Measurement Failure

This is usually caused by incorrect operation and may lead to an impedance measurement failure.

- Watch the instructional video and repeat the measurement: [Video Link]
 1. Enter the measurement screen
 2. Pull and hold the grips
 3. Stand barefoot on the electrode scale
 4. Wait until you hear “Body Fat Measurement Complete” or the report appears on screen
- If unresolved: The electrode scale batteries may be low. If “LO” appears, replace the batteries.

Machine Interface Freezes / Touchscreen Unresponsive

1. Press and hold the side button for 10+ seconds to shut down.
2. Wait 30 seconds.
3. Press and hold the power button for 3 seconds to restart.

Technical Support



Contact: support@aeke.com



MAINTENANCE AND CARE .

07

Notice: When cleaning the Product, unplug the power cord first.



1. Device Cleaning

- Power off and unplug the device.
- Use a clean, soft, dry cotton cloth to gently wipe the surface.
- Do not use chemical solutions, alcohol, or detergents.
- Avoid forceful wiping and do not use coarse or hard materials.

2. Screen Maintenance

- Power off the device before cleaning the screen
- Use a slightly damp cloth or an alcohol-based wet wipe to clean the screen.
- Ensure the screen is completely dry before powering the device back on to avoid affecting touch sensitivity.

3. Power Maintenance

- When not in use, press and hold the side button for more than 6 seconds to power off.
- After evening workouts, press and hold the back button to power off the device.

4. Resistance Cable Replacement

- The number of resistance cable uses can be checked via the machine interface when
- Using the resistance cable at 20 kg , contact AEKE after-sales support to request a cable replacement after reaching 60,000 pulls

5. Prohibitions

- If the product gets wet, do not use a hair dryer (hot air) to heat the affected area.
- Do not disassemble the product. Do not remove the back cover. Disassembly may cause damage, injury, and void the warranty.
- For internal inspection or adjustment, contact official customer service only. Do not use non-original parts or accessories for repair or replacement.

6. Precautions

- Do not modify the product or use it for purposes other than intended.
- Do not reverse-engineer, modify, or perform improper software upgrades.
- Do not cover the product with blankets, cloths, or other items during use to avoid blocking heat dissipation.
- The safety performance rating of this equipment can only be maintained through regular inspections of component damage and wear. Special attention must be paid to critical components such as ropes, pulleys, and connection points. The equipment must not be used without completing the required periodic inspections.
- In the event of equipment failure, the faulty component must be replaced immediately. If issues such as the pedal buckle failing to secure properly or the force-arm rope not retracting smoothly occur and cannot be promptly repaired, equipment operation should be suspended until the repairs are completed and safety is confirmed before resuming use.
- During daily use and inspection, special attention should be paid to wear-prone components of the equipment, such as the tension ends of ropes, screen sensitivity, and motion pedals. The wear condition should be monitored promptly, and maintenance or replacement should be performed as needed.
- If any adjustment device, such as the adjustable armor pedal, remains exposed, it may interfere with the user's movements and restrict the range of motion.
- Note: This device complies with industry stability standards when used for its intended purpose. Using the device as a support during stretching, or attaching resistance bands, ropes, or other devices to the device, may result in severe injuries.

7. Permanent marker

- Age range: Adults aged ≥ 18 years can register an account independently.
 1. Users aged 18 and above can use the device independently
 2. For use by adolescents and children under 18 years of age, a guardian must be present throughout the operation, and an observer must always be present when operating the device.
- The maximum user weight is ≤ 150 kg; the force arm training load is ≤ 150 kg; the training load for the entire machine and exercise pedal may be ≥ 150 kg. Warning: Do not exceed the equipment's capacity.
- The motor's load range is 2.5 kg to 50 kg per side.
- Motor gear interval: 0.5 kg for precise adjustment
- The product meets Class H performance requirements with Class C precision, complying with the HC standard under ISO 20957 regulations.

**WARRANTY AND
AFTER-SALES SERVICE .**

08

Overview

Name of the applicant company and manufacturer: Qudong Future (Shenzhen) Technology Co., Ltd.

Address: 1001, Block A, Wanhai Building, Zhaoshang Street, Nanshan District, Shenzhen, Guangdong Province

This warranty clause outlines the user rights for the AEKE S1 Series Smart Home Gym.

Additional rights may apply in accordance with local laws and regulations.

Please review this section for warranty terms and service procedures.

For complete legal details, please refer to local regulations or visit www.aeke.com.

Limited Product Warranty

- AEKE warrants that your S1 RPO Smart Home Gym, when used and maintained per this manual, will be free from defects in materials and workmanship during the warranty period. Free repairs are provided for defects within this period. Outside the warranty period or for user-caused damage, paid repairs are available. This applies only to products purchased from AEKE or authorized dealers.

Limited Product Warranty

- Starts on delivery date (per receipt, invoice, or order).
- If no proof of purchase, starts 30 days after factory delivery.

Device	Item	Standard Warranty Period
S1 Series Smart Home Gym	Motor, Screen, Power Supply, etc	24 months
FITNESS BENCH	Fitness Bench	12 months
Accessories	Smart Grips, Cross-bar, Resistance Controller, Arm Band, Electrode Scale, etc	12 months

Free Repair Conditions

Free repairs apply if:

- Purchased from AEKE or authorized dealer.
- Defect occurs within warranty period (not user-caused).
- Used for personal/household purposes only.
- No unauthorized modifications or disassembly.
- Proof of purchase and serial number (SN) provided.

Exclusions

- Misuse or failure to follow this manual.
- Unauthorized repairs or non-AEKE parts.
- Extreme conditions (e.g., heat, corrosion).
- Normal wear (e.g., scratches, rust).
- Data loss from improper use.

How to Get Service

If your product fails within warranty, email support@aeke.com within 30 days of noticing the issue. **Provide:**

- Proof of purchase (e.g., receipt, order number).
- Serial number (SN).

AEKE will troubleshoot remotely. If needed, send the product for repair. For valid claims, AEKE covers costs. For non-warranty issues, you may pay for parts, labor, and shipping.

Contact Us:

- For support, email support@aeke.com. Expect a response within 24 hours, Monday through Saturday.
- For more details, visit www.aeke.com or refer to AEKE's privacy policy.



RETURN AND REFUND POLICY .

09

Overview

Not satisfied with your S1 Series Smart Home Gym?

You can request a return and refund within 30 days of receiving it, following this policy.

How to Return or Get a Refund

- Email support@aeke.com within 30 days of delivery.
- Include your order number, product name, quantity, reason for return, and photos/videos of the full packaging.
- We'll review your request within 2 business days.
- After we receive and check the returned product, we'll refund you using your original payment method.

Full Refund Conditions

You'll get a full refund if:

- You contact support@aeke.com within 30 days with valid proof of purchase (e.g., receipt or order number).
- The product has defects or quality issues right out of the box and is still in new or like-new condition.
- It's returned with all original packaging, accessories, and attachments.

Partial Refund Conditions

You'll get a partial refund if:

- The return isn't due to defects or quality issues.
- The product is missing accessories, attachments, or has visible damage (e.g., scratches, dents).
- It's not in its original packaging or was damaged due to poor packaging. We'll assess the condition and deduct fees, which we'll confirm with you.

No Refund Conditions

Refunds aren't available if:

- You request it more than 30 days after delivery.
- The product is damaged and can't be used or resold.
- Damage is from misuse, unauthorized changes, or not following this manual.
- Damage is due to events like fire or flood.
- The product is activated/registered (if applicable).
- It's a custom-made item.
- You don't have valid proof of purchase or it's been altered.
- Serial numbers don't match or are tampered with.

Refund Timing

Refunds go back to your original payment method within 7–14 business days after we receive and verify the product. Timing depends on your bank or card issuer.

- Delayed Refund? Check your bank account, then contact your card issuer. Still no refund? Email support@aeke.com.

Shipping Costs

- Defects: We cover shipping for returns due to quality issues within 30 days.
- Other Reasons: You pay shipping for returns not related to defects.

Issue	AEKE	Client
Non-quality issue return/exchange	✗	✓
Quality issue return/exchange	✓	✗
Repairs within the warranty period	✓	✗
Repairs outside the warranty period	✗	✓



FCC & CE STATEMENT.

10

FCC Statement

This equipment has been tested and found to comply with the limits for a Class B digital device, pursuant to Part 15 of the FCC Rules. Any changes or modifications not expressly approved by the party responsible for compliance could void the user's authority to operate the equipment. These limits are designed to provide reasonable protection against harmful interference in a residential installation. This equipment generates, uses and can radiate radio frequency energy and, if not installed and used in accordance with the instructions, may cause harmful interference to radio communications. However, there is no guarantee that interference will not occur in a particular installation. If this equipment does cause harmful interference to radio or television reception, which can be determined by turning the equipment off and on, the user is encouraged to try to correct the interference by one or more of the following measures:

- Reorient or relocate the receiving antenna.
- Increase the separation between the equipment and receiver.
- Connect the equipment into an outlet on a circuit different from that to which the receiver is connected.
- Consult the dealer or an experienced radio/TV technician for help.

Radiation Exposure Statement.

S1 Series Smart Home Gym This device complies with FCC radiation exposure limits set forth for an uncontrolled environment and it also complies with Part 15 of the FCC RF Rules. This equipment should be installed and operated with a minimum distance 20cm between the device and your body.

This device complies with part 15 of the FCC Rules. Operation is subject to the following two conditions: (1) This device may not cause harmful interference, and (2) this device must accept any interference received, including interference that may cause undesired operation.

Changes or modifications not expressly approved by the party responsible for compliance could void the user's authority to operate the equipment.

S1 Series Smart Home Gym

Inside the room: The device is restricted to indoor use only when operating in 5150 to 5250MHz frequency range

20cm Evaluation: The antennas used for this transmitter must be installed to provide a separation distance of at least 20cm from all persons and must not be located or operating in conjunction with any other antenna or transmitter.

	BE	BG	CZ	DK	DE	EE	IE	EL	ES	FR
	LV	LT	LU	HU	MT	NL	AT	PL	PT	RO
	SE	TR	NO	CH	IS	LI	HR	IT	CY	SI
	SK	FI								

S1 Series Smart Home Gym

FCC ID : 2BKQVSHG2501-1

Smart Grips FCC ID:2BKQVSHG2501-2

Federal Communications Commission Number:

Manufacturer: Qudong Future (Shenzhen) Technology Co., Ltd.

Address: 1001 Wanhai Building, No.1031 Industrial 5th Road, Nanshan District, Shenzhen, China,
Postal Code: 518000

CE Statement

Item	Details
Product Name and Model	S1 Series Smart Home Gym(Model: SHG2501-1)
Manufacturer	Qudong Future (Shenzhen) Technology Co., LTD. Address: Room 1001, Wanhai Building, No.1031, Industrial 5th Road, Nanshan District, Shenzhen
Declaration of Conformity	This product complies with the essential requirements and other relevant provisions of the EU Radio Equipment Directive (2014/53/EU).
Certification Number	EMC260127032-01-001, RF260127032-01-001,RF260127032-01-002,RF260127032-01-003,RF260127032-01-004,RF260127032-01-005,RF260127032-01-006,SAF260127032-01-001
Test Standard – EMC	EN 55032:2015+A1:2020; EN IEC 61000-3-2:2019+A2:2024; EN 61000-3-3:2013+A2:2021+AC:2022; EN 55035:2017+A11:2020; ETSI EN 301 489-1 V2.2.3 (2019-11); ETSI EN 301 489-3 V2.3.2 (2023-01); ETSI EN 301 489-17 V3.3.1 (2024-09)
Test Standard – Radio	ETSI EN 300 328 V2.2.2 (2019-07); ETSI EN 301 893 V2.2.1 (2024-11); ETSI EN 300 440 V2.2.1 (2018-07)
Test Standard — Health	EN IEC 62311:2020
Test Standard – Safety	IEC 62368-1:2018 , EN IEC 62368-1:2020+A11:2020
Radio Frequency Exposure Information	Complies with the EU RF exposure requirements specified in the EN IEC 62311 standard. Maintain a minimum distance of at least 20 cm from the human body during use.

Item	Detailed information
Product Name and Model	Smart Grips (Model: SHG2501-2)
Manufacturer	Qudong Future (Shenzhen) Technology Co., LTD. Address: Room 1001, Wanhai Building, No.1031, Industrial 5th Road, Nanshan District, Shenzhen
Compliance Statement	This product complies with the fundamental requirements and other relevant provisions of the EU Radio Equipment Directive (2014/53/EU).
Certification Number	EMC260127032-02-001, RF260127032-02-001,RF260127032-02-002,SAF260 127032-02-001
Test Standard – EMC	EN 55032:2015+A1:2020; EN IEC 61000-3-2:2019+A2:2024;EN 55035:2017+A11:2020; EN 61000-3-3:2013+A2:2021+AC:2022ETSI EN 301 489-1 V2.2.3 (2019-11)ETSI EN 301 489-17 V3.3.1 (2024-09)
Test Standard – Radio	ETSI EN 300 328 V2.2.2 (2019-07)
Test Standard — Health	EN 62479:2010
Test Standard – Safety	IEC 62368-1:2018,EN IEC 62368-1:2020+A11:2020
Radio Frequency Exposure Information	Complies with the EU RF exposure requirements specified in the EN IEC 62311 standard.

STAY IN TOUCH



Instagram

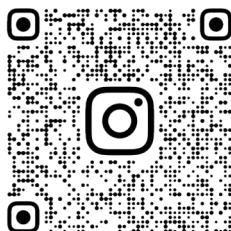

Facebook



Youtube



Official AEKE Community

