

Product Manual



**12.5 Amp/ Variable Speed/ 2-1/4
Peak HP**

Fixed Base Router

Model No. 320. 28190

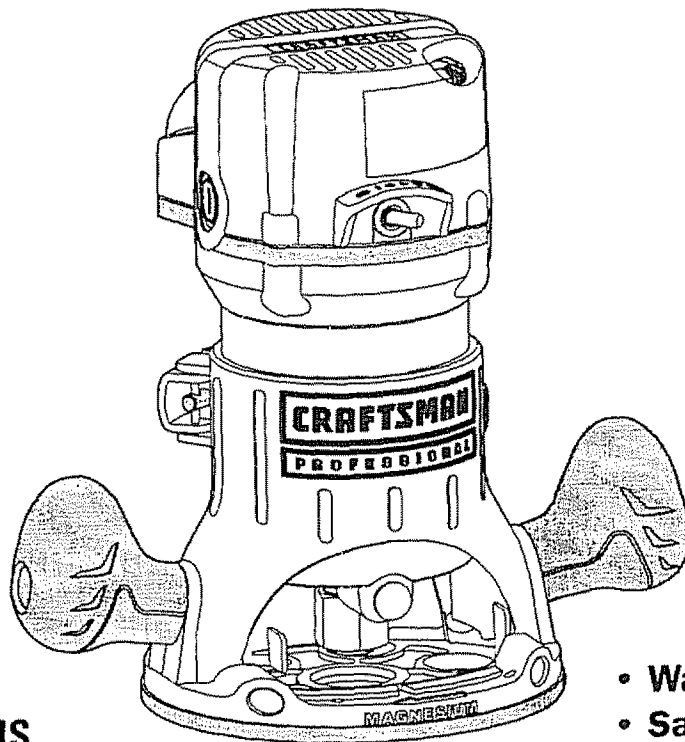

▲ CAUTION! Read, understand and follow all Safety Rules and Operating Instructions in this Manual before using this product.

- Warranty
- Safety
- Unpacking
- Assembly
- Description
- Operation
- Adjustments
- Maintenance
- Troubleshooting

Sears, Roebuck and Co., Hoffman Estates, IL 60179

www.craftsman.com

TABLE OF CONTENTS

Warranty	Page 2
Safety Symbols	Page 3
Safety Instructions	Page 4-11
Unpacking	Page 11-12
Description	Page 13-15
Assembly	Page 15-19
Operation	Page 19-32
Maintenance	Page 33-34
Troubleshooting	Pages 35
Accessories	Pages 36
Parts list	Pages 37-42
Sears Repair Parts Phone and Numbers	Back Cover

ONE YEAR FULL WARRANTY ON CRAFTSMAN TOOL

If this Craftsman tool fails to give complete satisfaction within one year from the date of purchase, return it to any Sears store or parts & repair center or other craftsman outlet in the United States for free repair (or replacement, if repair proves impossible).

This warranty does not include expendable parts such as lamps, batteries, bits, or blades.

This warranty applies for only 90 days from the date of purchase if this product is ever used for commercial or rental purposes

This warranty gives you specific legal rights, and you may also have other rights which vary from state to state.

Sears, Roebuck and Co., Hoffman Estates IL 60179

▲ WARNING: Some dust created by using power tools contains chemicals known to the state of California to cause cancer and birth defects or other reproductive harm.

**SAVE THESE INSTRUCTIONS!
READ ALL INSTRUCTIONS!**

SAFETY SYMBOLS

The purpose of safety symbols is to attract your attention to possible dangers. The safety symbols, and the explanations with them, deserve your careful attention and understanding. The symbol warnings **DO NOT**, by themselves, eliminate any danger. The instructions and warnings they give are no substitutes for proper accident-prevention measures.

▲ WARNING: BE SURE to read and understand all safety alert symbols, such as “DANGER,” “WARNING,” and “CAUTION” BEFORE using this product. Failure to follow all instructions may result in electric shock, fire, and/or serious personal injury.

SYMBOL MEANINGS

▲ SAFETY ALERT SYMBOL: Indicates **DANGER, WARNING, OR CAUTION.** May be used in conjunction with other symbols or pictographs.

▲ DANGER: Failure to obey this safety warning **WILL** result in death or serious injury to yourself or to others. Always follow the safety precautions to reduce the risk of fire, electric shock and personal injury.

▲ WARNING: Failure to obey this safety warning **CAN** result in death or serious injury to yourself or to others. Always follow the safety precautions to reduce the risk of fire, electric shock and personal injury.

▲ CAUTION: Failure to obey this safety warning **MAY** result in personal injury to yourself or others or property damage. Always follow the safety precautions to reduce the risk of fire, electric shock and personal injury.

DAMAGE PREVENTION AND INFORMATION MESSAGES

These inform the user of **important information and/or instructions** that could lead to equipment or other property damage if they are not followed. Each message is preceded by the word “NOTE,” as in the example below:

NOTE: Equipment and/or property damage may result if these instructions are not followed.



▲ WARNING: The operation of any router can result in foreign objects being thrown into your eyes, which can result in severe eye damage. Before beginning power tool operation, **ALWAYS** wear safety goggles or safety glasses with side shield and a full-face shield when needed. We recommend a **Wide Vision Safety Mask** for use over eyeglasses or standard safety glasses with side shield, available at **Sears Stores** or other **Craftsman Outlets**.

SAFETY INSTRUCTIONS

⚠ WARNING: BE SURE to read and understand all instructions in this manual before using this router. Failure to follow all instructions may result electric shock, fire and/or serious personal injury.

WORK AREA SAFETY

- **Keep your work area clean and well lit.** Cluttered workbenches and dark areas invite accidents.
- **DO NOT operate power tools in explosive atmospheres, such as in the presence of flammable liquids, gases, or dust.** Power tools create sparks which may ignite the dust or fumes.
- **Keep bystanders, children and visitors away while operating a power tool.** Distractions can cause you to lose control.
- **Make your workshop childproof** with padlocks and master switches. Lock tools away when not in use.
- **MAKE SURE the work area has ample lighting** so you can see the work and that there are no obstructions that will interfere with safe operation **BEFORE** using your router.

PERSONAL SAFETY

- **KNOW your power tool.** Read this operator's manual carefully. Learn the router's applications and limitations, as well as the specific potential hazards related to this tool.
- **STAY ALERT,** watch what you are doing and use common sense when operating a power tool.
- **DO NOT** use tool while tired or under the influence of drugs, alcohol or medication. A moment of inattention while operating power tools may result in serious personal injury.
- **DRESS properly. DO NOT** wear loose clothing or jewelry. Pull back long hair. Keep your hair, clothing, and gloves away from moving parts. Loose clothing, or long hair can be caught in moving parts. Air vents often cover moving parts and should also be avoided.
- **AVOID** accidental starting. Be sure switch is in "**OFF**" position before plugging in. **DO NOT** carry tools with your finger on the switch. Carrying tools with your finger on the switch or plugging in tools that have the switch in the "**ON**" position invites accidents.
- **REMOVE** adjusting keys or blade wrenches before turning the tool "**ON.**" A wrench that is left attached to a rotating part of the tool may result in personal injury.
- **Do not overreach. Keep proper footing and balance at all times.** Proper footing and balance enables better control of the tool in unexpected situations.

- **ALWAYS SECURE YOUR WORK.** Use clamps or a vise to hold work piece securely. It is safer than using your hand and frees both hands to operate tool.
- **USE SAFETY EQUIPMENT.** Always wear eye protection. Dust mask, non-skid safety shoes, hard hat, or hearing protection must be used for appropriate conditions.
- **DO NOT USE ON A LADDER or unstable support.** Stable footing on a solid surface enables better control of the tool in unexpected situations.

TOOL USE AND CARE

 **WARNING: BE SURE to read and understand all instructions before operating this router. Failure to follow all instructions listed below may result in electric shock, fire and/or serious personal injury.**

- **ALWAYS use clamps or other practical ways to secure and support the work piece to a stable platform.** Holding the work by hand or against your body is unstable and may lead to loss of control.
- **DO NOT force the tool. Use the correct tool and bit for your application.** The correct tool and bit will do the job better and safer at the rate for which it is designed.
- **DO NOT use the tool if switch does not turn it “On” or “Off.”** Any tool that cannot be controlled with the switch is dangerous and must be repaired.
- **DISCONNECT the plug from the power source before making any adjustments, changing accessories or storing the tool.** Such preventive safety measures reduce the risk of starting the tool accidentally.
- **NEVER leave the tool running. ALWAYS turn it off. DO NOT** leave the tool until it comes to a complete stop.
- **STORE idle tools out of the reach of children and other untrained persons.** Tools are dangerous in the hands of untrained users.
- **MAINTAIN tools with care. Keep cutting tools sharp and clean.** Properly maintained tools with sharp cutting edges are less likely to bind and are easier to control.
- **CHECK for misalignment or binding of moving parts, breakage of parts, and any other condition that may affect the tool’s operation.** If damaged, have the tool serviced before using. Many accidents are caused by poorly maintained tools.
- **USE ONLY accessories that are recommended for this tool.** Accessories that may be suitable for one tool may become hazardous when used on another tool.

ELECTRICAL SAFETY

⚠ WARNING: Do not permit fingers to touch the terminals of plug when installing or removing the plug from the outlet.

- **Double insulated tools are equipped with a polarized plug (one blade is wider than the other). This plug will fit in a polarized outlet only one way.** If the plug does not fit fully in the outlet, reverse the plug. If it still does not fit, contact a **qualified electrician** to install a polarized outlet. Do not change the plug in any way.
- Double insulation **■** eliminates the need for the three-wire grounded power cord and grounded power supply system. Applicable only to Class II (double-insulated) tools. **This router motor is double insulated.**

⚠ WARNING: Double insulation **DOES NOT** take the place of normal safety precautions when operating this tool.

- **BEFORE** plugging in the tool, **BE SURE** that the outlet voltage supplied is within the voltage marked on the tool's data plate. **DO NOT** use "AC only" rated tools with a DC power supply.
- **AVOID body contact with grounded surfaces**, such as pipes, radiators, ranges and refrigerators. There is an increased risk of electric shock if your body is grounded.
- **DO NOT expose power tools to rain or wet conditions or use power tools in wet or damp locations.** Water entering a power tool will increase the risk of electric shock.
- **INSPECT tool cords for damage.** Have damaged tool cords repaired at a Sear Service Center. **BE SURE** to stay constantly aware of the cord location and keep it well away from the moving router.
- **DO NOT abuse the cord. NEVER use the cord to carry the tool by or to pull the plug from the outlet.** Keep cord away from heat, oil, sharp edges or moving parts. Replace damaged cords immediately. Damaged cords increase the risk of electric shock.

EXTENSION CORDS





Use a proper extension cord. ONLY use cords listed by Underwriters Laboratories (UL). Other extension cords can cause a drop in line voltage, resulting in a loss of power and overheating of tool. For this tool an AWG (American Wire Gauge) size of at least 14-gauge is recommended for an extension cord of 25-ft or less in length. Use 12-gauge for an extension cord of 50-ft. **Extension cords 100-ft or longer are not recommended. Remember, a smaller wire gauge size has greater capacity than a larger number** (14-gauge wire has more capacity than 16-gauge wire; 12-gauge wire has more capacity than 14-gauge). When in doubt use the smaller number. When operating a power tool outdoors, use an outdoor extension cord marked "W-A" or "W." These cords are rated for outdoor use and reduce the risk of electric shock.

 **CAUTION:** Keep the extension cord clear of the working area. Position the cord so that it will not get caught on lumber, tools or other obstructions while you are working with a power tool.

 **WARNING:** Check extension cords before each use. If damaged replace immediately. Never use tool with a damaged cord since touching the damaged area could cause electrical shock, resulting in serious injury.

SAFETY SYMBOLS FOR YOUR TOOL

The label on your tool may include the following symbols.

- VVolts
- A.....Amps
- Hz.....Hertz
- W.....Watts
- min.....Minutes
- Alternating current
- Direct current
- n_0 No-load speed
- Class II construction, Double Insulated
- .../min.....Revolutions or Strokes per minute
-  Indicates danger, warning or caution. It means attention! Your safety is involved.

SERVICE SAFETY

- **If any part of this router is missing or should break, bend, or fail in any way; or should any electrical component fail to perform properly: SHUT OFF** the power switch and remove the router plug from the power source and have the missing, damaged or failed parts replaced **BEFORE** resuming operation.
- **Tool service must be performed only at a Sears Parts and Repair Center.** Service or maintenance performed by unqualified personnel could result in a risk of injury.
- **When servicing a tool, use only identical replacement parts. Follow instructions in the maintenance section of this manual.** Use of unauthorized parts or failure to follow maintenance instructions may create a risk of electric shock or injury.



SAFETY RULES FOR ROUTER

 **CAUTION:** Cutting bits coast after router is switched off.

- **HOLD TOOL** by insulated gripping surfaces (handles) when performing an operation where the cutting tool may contact hidden wiring or its own cord. Contact with a “live” wire will make the exposed metal parts of the tool “live” and shock the operator.
- **Maintain a firm grip** on the router with both hands to resist starting torque.
- **NEVER attempt to use the router motor without first installing it in an approved fixed base.** Failure to heed this warning could result in personal injury and damage to the router motor.
- **MAKE SURE the router motor does not move up or down when clamped in the fixed base.** If router motor is not securely clamped in base, adjustments will not be accurate.
- **DO NOT HAND-HOLD THE ROUTER IN AN UPSIDE DOWN OR HORIZONTAL POSITION.** The router motor can separate from the base if not properly attached according to the instructions.
- **TIGHTEN COLLET/NUT securely to prevent the cutting bit from slipping.** If the collet/nut is not securely tightened, the cutting bit may detach during use, causing serious personal injury.
- **NEVER tighten collet/nut without a cutting bit installed in the collet/nut.**
- **USE CLAMPS or other practical ways to secure and support the work piece to a stable platform and hold the work piece rigidly in position.** Holding the work by hand or against your body is unstable and may lead to loss of control.
- **NEVER hold the piece being cut in your hands or across your legs.** It is important to support and clamp the work piece properly in order to minimize body exposure, bit binding, or loss of control.
- **ALWAYS keep chip shield clean and in place.**
- **STAY ALERT and clear the Router cutting bit path of any obstructions BEFORE starting the router motor.** Keep cutting area clear of all foreign objects while router motor is running.
- **CHECK TO SEE that the cord will not “hang up” during routing operation.**
- **MAKE SURE the cutting bit is not in contact with the work piece before the switch is turned on.** The bit must **ALWAYS** be running at full speed before contacting the work piece.
- **KEEP HANDS CLEAR OF CUTTING BIT** when router motor is running to prevent personal injury.

- **PROVIDE CLEARANCE** under work piece for router cutting bit when through-cutting.
- **KEEP CUTTING PRESSURE CONSTANT.** Do not overload the motor.
- **USE ONLY sharp cutting bits that are not chipped or cracked. Blunt cutting bits will cause stalling and burn the work piece.**
- **NEVER use this router motor with a cutting bit larger than 3-1/2 inch in diameter.**
- **ALWAYS USE cutting bits that are designed for this router. Never use cutting bits which are larger in diameter than the opening in the router sub-base.** Cutting bits that have cutter diameters larger than the opening could cause possible loss of control or create other hazardous condition that could cause serious personal injury.
- **The sub-base on this fixed base router has an opening of 1-1/4 inch.** To use cutting bits with a larger diameter, install and use a sub-base with a larger diameter opening (sold separately) at Sears stores or other Craftsman outlets.
- **DO NOT use large router cutting bits for freehand routing.** Use of large cutting bits when freehand routing could cause loss of control or create hazardous conditions that could result in serious personal injury. If using a router table, large bits should be used for edging only.
- **BE SURE CUTTING BIT is centered in template guide (sold separately) prior to template guide applications to avoid personal injury or damage to finished work.**
- **DO NOT REMOVE more than 1/8 inch. in a single pass.** Excessive depth of cut can result in loss of control that could result in personal injury.
- After completing a cut, **turn motor OFF** and let it come to a complete stop **BEFORE REMOVING router from work piece.**
- **Let the motor come to a COMPLETE STOP before putting the router down.** Cutting bits coast after power is turned off.
- **ONLY use router tables that conform to safe woodworking practices and offer proper guarding for the cutting bit.** Use router tables that are UL classified and identified suitable for use with this specific router model. Failure to comply could result in serious personal injury.
- **Only use router tables with on-board switch controlled receptacles.** Failure to use router tables with all the appropriate safety features could result in serious personal injury.
- **DISCONNECT THE TOOL FROM POWER SOURCE** before making any adjustments or changing cutting bits.
- **If you are changing a bit immediately after use, BE CAREFUL NOT TO TOUCH the collet/nut or cutting bit with your hands or fingers.** The heat buildup from cutting could cause severe burns. **ALWAYS use the wrench provided.**

- **AVOID “CLIMB CUTTING.”** See “**OPERATION**” section in this manual. “Climb-cutting” increases the chance for loss of control resulting in possible serious injury.

⚠ WARNING: Use of this product can generate dust containing chemicals known to the state of California to cause cancer, birth defects or other reproductive harm. Some examples of these chemicals are:

- Lead from lead-based paints.
- Crystalline silica from bricks and cement and other masonry products.
- Arsenic and chromium, from chemically treated lumber.

Your risk from these exposures varies, depending upon how often you do this type of work. To reduce your exposure to these chemicals:

- Work in a well-ventilated area.
- Work with approved safety equipment, such as those dust masks that are specially designed to filter out microscopic particles.

Avoid prolonged contact with dust from power sanding, sawing, grinding, drilling and other construction activities. Wear protective clothing and wash exposed areas with soap and water. Allowing dust to get into your mouth, eyes or lay on the skin may promote absorption of harmful chemicals.

⚠ WARNING: Use of this tool can generate and/or disburse dust, which may cause serious and permanent respiratory or other injury. Always use NIOSH/OSHA approved respiratory protection appropriate for the dust exposure. Direct particles away from face and body.

ADDITIONAL RULES FOR SAFE OPERATION

⚠ WARNING: BE SURE to read and understand all instructions. Failure to follow all instructions listed below may result in electric shock, fire and/or serious personal injury.

- **Know your power tool. Read this operator’s manual carefully.** Learn the applications and limitations, as well as the specific potential hazards related to this tool. Following this rule will reduce the risk of electric shock, fire or serious injury.
- **ALWAYS wear safety glasses or eye shields when using this router.** Everyday eyeglasses have only impact-resistant lenses; they are NOT safety glasses.
- **PROTECT your lungs.** Wear a face mask or dust mask if the operation is dusty.
- **PROTECT your hearing.** Wear appropriate personal hearing protection during use. Under some conditions noise from this product may contribute to hearing loss.
- **ALL VISTORS AND BYSTANDERS MUST** wear the same safety equipment that the operator of the router wears.

- **INSPECT** the tool cords periodically and if damaged have them repaired at your nearest Sears Service Center. **BE AWARE** of the cord location.
- **ALWAYS** check the tool for damaged parts. Before further use of the tool, a guard or other part that is damaged should be carefully checked to determine if it will operate properly and perform its intended function. Check for misalignment or binding of moving parts, breakage of parts, and any other condition that may affect the tool's operation. A guard or other part that is damaged should be properly repaired or replaced at a Sears Service Center.
- **INSPECT** and remove all nails from lumber before routing.
- **SAVE THESE INSTRUCTIONS.** Refer to them frequently and use them to instruct others who may use this tool. If someone borrows this tool, make sure they have these instructions also.

UNPACKING

⚠ WARNING: Your router should **NEVER** be connected to the power source when you are assembling parts, making adjustments, installing or removing collets / nuts, cutting bits, cleaning or when it is not in use. Disconnecting the router will prevent accidental starting, which could cause serious personal injury.

1. Carefully lift the Router Motor and Fixed Base, with the 1/2 in. collet/nut already installed, out of the color box and place it on a stable, flat surface.
2. Open the parts bag to locate the following:
 - Edge Guide
 - 1/4-in. Collet/Nut
 - Collet/Nut wrench
 - Power cord
 - Sawdust extraction adapter
 - Depth-adjustment wrench
3. Inspect the items carefully to make sure that no breakage or damage has occurred during shipping. If any of the items mentioned are missing, (refer to "PARTS LIST" illustration on page 12), return the router to your nearest Sears store or Craftsman outlet to have the router replaced.

⚠ WARNING: If any parts are broken or missing, **DO NOT** attempt to plug in the power cord or operate router until the broken or missing parts are replaced. Failure to do so could result in possible serious injury.

PARTS LIST (Fig. 1)

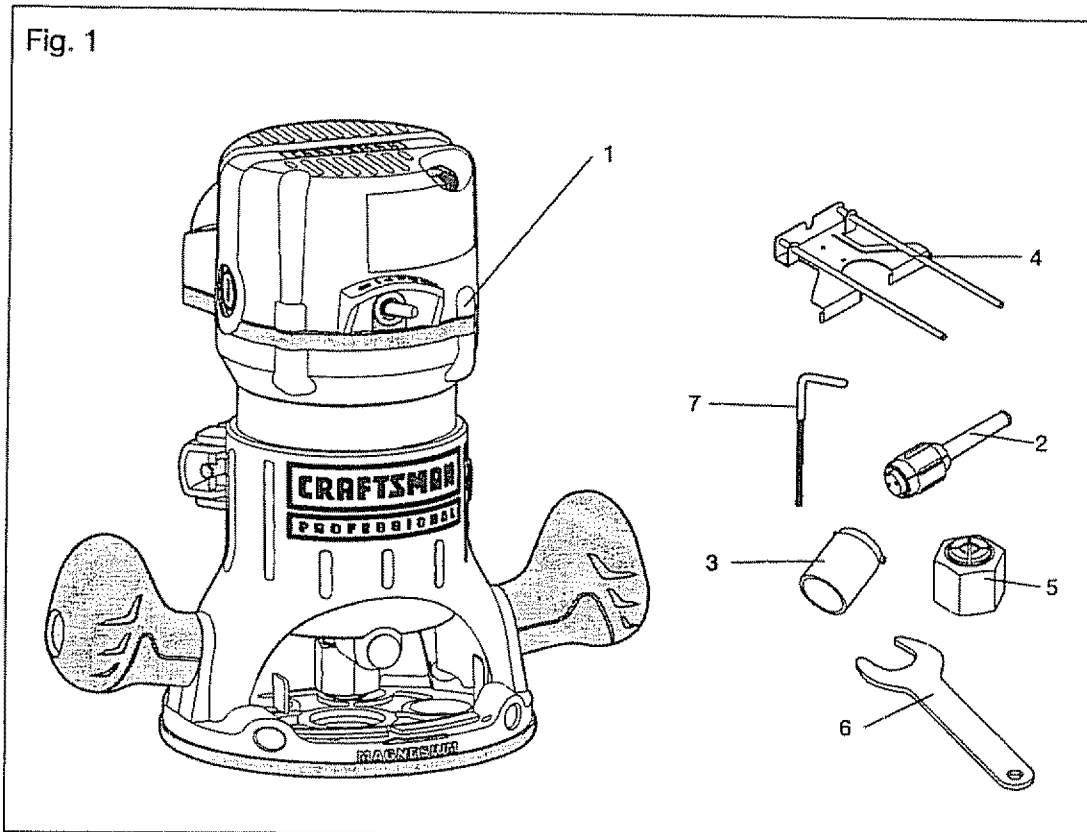

1. Fixed Base and Router Motor with 1/2-in. Collet/Nut
2. Power cord
3. Sawdust extraction adapter
4. Edge Guide
5. 1/4-in. Collet/Nut
6. Collet/Nut Wrench
7. Depth-adjustment wrench

DESCRIPTION

KNOW YOUR FIXED BASE ROUTER (Fig. 2)

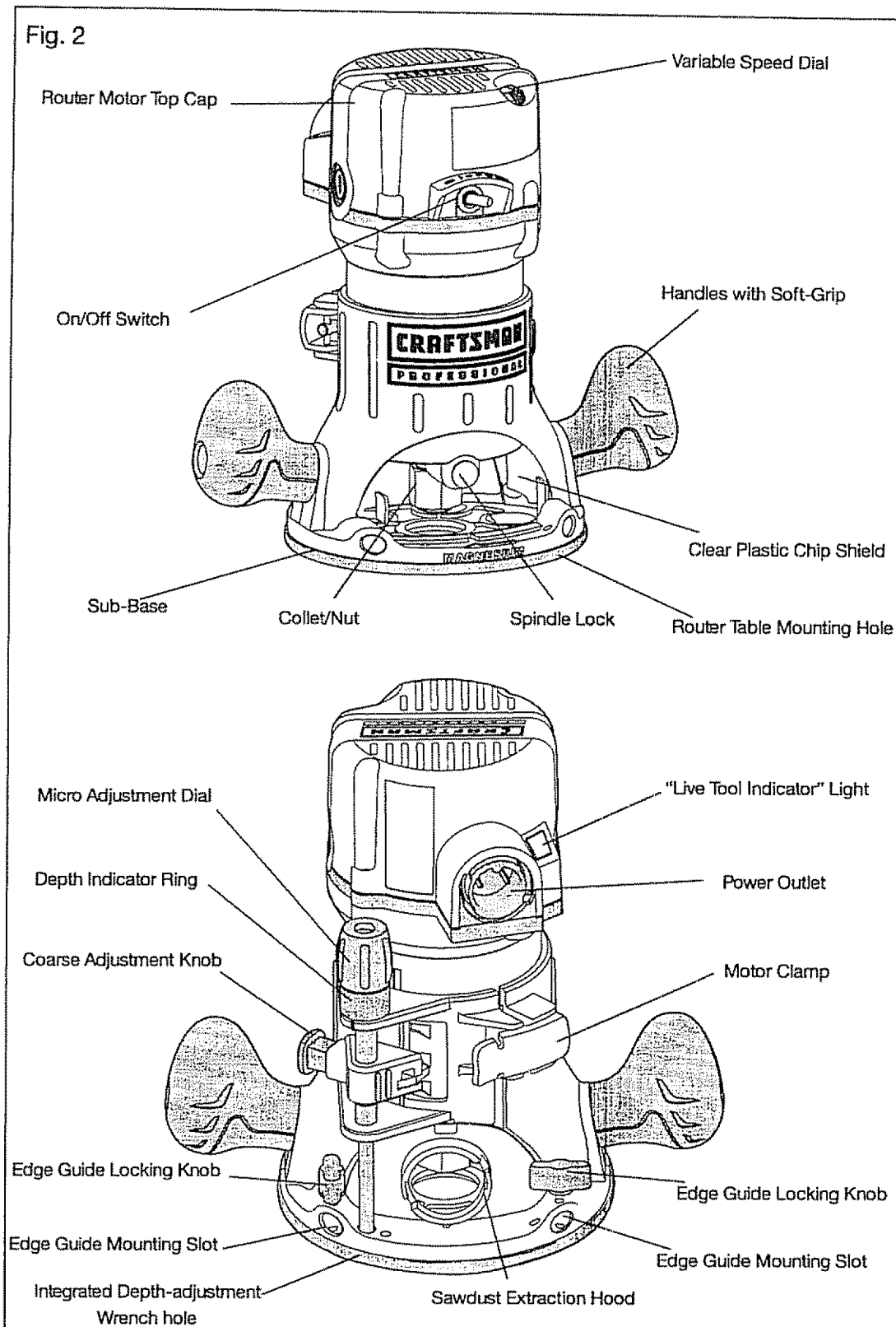

PRODUCT SPECIFICATIONS	
Rating	12.5 Amps
No load Speed	12000-25000RPM
Peak HP	2-1/4
Input	120-volts, 60Hz AC
Collets/Nuts and Cutting Bit Shank Diameters	1/4 in. 1/2 in.
Fixed Base Diameter	6 inches
Sub Base Opening (Diameter for cutting bit use)	1-1/4 inches
Sub Base Thickness	0.23 inches (6mm)
Fixed Base Depth of Cut	1-3/4 inches (45mm)

NOTE: Before attempting to use your router, familiarize yourself with all of the operating features and safety requirements.

Your fixed base router has a precision-built electric router motor and it should only be connected to a 120-volt, 60-Hz AC ONLY power supply (normal household current). **DO NOT** operate on direct current (DC). This large voltage drop will cause a loss of power and the router motor will overheat. If the router does not operate when plugged into a correct 120-volt, 60-Hz AC ONLY outlet, check the power supply. This router has a 10-ft, 2-wire power cord (no adapter needed).

This Fixed Base Router has the following features:

1. **12.5 Amp, 2-1/4 Peak HP, Variable Speed Router Motor runs at 12,000 to 25,000 RPM (no-load speed).**
2. **Speed Dial** allows matching proper speed to material and bit size.
3. **Electronic Feedback Circuitry** provides soft starts for longer motor life, maintains constant speed under load for a quality finish in all materials.
4. **Fixed Base features Coarse and Fine Depth Adjustments** for accurate set-ups. Ideal for use with router table, sold separately.
5. **Spindle Lock** for easy 1 wrench bit changes. Includes **1/4 and 1/2 inch Self-Releasing Collets/Nuts** for use with a wide variety of 1/4 in. and 1/2 in. router bits, sold separately.
6. **Detachable power cord:** a replaceable cord to prolong tool life and for easy carrying and storage.
7. **Ball bearings throughout the motor** for smooth, efficient operation and long life.
8. Base features **Ergonomically Designed Handles** with soft grip for comfort, maximum control with less vibration.
9. **Base features Large Base Opening and Large Chip Shield, combined with 3 LED Work lights on Router Motor** to provide high visibility of bit and work piece.

10. **Durable Non-Marring Sub-Base** glides smoothly over work piece. Sub-base has cutter-bit opening of 1-1/4 inch. Do Not Use a bit with a cutter diameter larger than 1-1/4 in., as it will not pass through the sub-base opening!
11. **Base constructed of magnesium** to provide light weight, durability and stability.
12. **Router Motor housing** constructed of High Density Nylon and Precision Milled Cast Aluminum for strength and exact fit into base.
13. High-impact resistant **Router Motor Top Cap and Handles on Base** helps protect tool from damage.
14. Heavy-duty **Edge Guide** for most routing applications such as decorative edging, grooving, dadoing, slotting and straight edge planing /rimming.
15. Conveniently located **On/Off Toggle Switch**, side mounted for added visibility, easy access.
16. **Sawdust Extraction Hood** allows base to hook up to 1-1/4 inch vacuum hose attachment, sold separately.
17. **“LIVE TOOL INDICATOR” Light** is green when saw is plugged into a power source. Light is located on router motor top cap next to power cord inlet.
18. **Replaceable Brushes** (sold separately) for dependable service.
19. Includes **carry bag** for easy carrying and storage.
20. **Integrated Depth-adjustment Wrench hole** of the base for adjusting the depth of cut from above the table with depth-adjustment wrench.

ASSEMBLY

NOTE: This tool is shipped completely assembled. To install or remove bits or add accessories such as sawdust ejection hoods for hook-up to vacuums, see the following instructions.

SELECTING THE CUTTING BIT

This router comes with 1/4-in. and 1/2-in. collets/nuts that accept 1/4 and 1/2 inch diameter shanked cutting bits.

⚠ WARNING: Do not use router cutting bits that have a cutting bit diameter larger than 1-1/4 inches as they will not fit through the sub-base opening, and will cause damage to the sub-base, the router motor, and could cause serious personal injury to the operator.

NOTE: The sub-base installed on this router has an opening of 1-1/4 inches. To use cutting bits with a larger diameter, use a sub-base with a larger opening, sold separately at Sears stores or other Craftsman outlets.

⚠ WARNING: ALWAYS turn router motor off and unplug router before making any adjustments or installing accessories. Failure to unplug the router could result in accidental starting which can cause serious personal injury.

INSTALLING AND REMOVING THE CUTTING BIT (Figs. 3, 4 and 4a)

INSTALLING THE CUTTING BIT

1. Turn router motor off and unplug from power source.
2. Remove router motor from fixed base.

NOTE: See instructions on removing and installing the router motor in the fixed base on page 18.

3. Set the router motor upside down on its top cap, with collet/nut pointing up.
4. Press spindle lock button to engage and lock the spindle shaft and collet/nut (Fig. 3).
5. Place the wrench on the collet/nut and turn counter-clockwise and loosen collet/nut slightly to accept cutting bit shank.
6. Insert cutting bit shank into collet/nut assembly as far as it will go, then back the shank out until the cutters are approximately 1/8 to 1/4 inch away from the face of the collet/nut (Fig. 4, 4a)
7. With cutting bit inserted and spindle lock button pressed in engaging shaft, place wrench on collet/nut and turn clockwise until router cutting bit and collet/nut are firmly tightened.

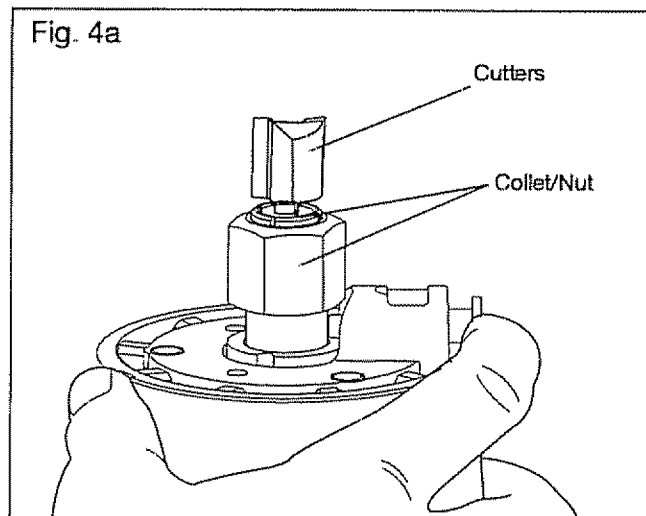
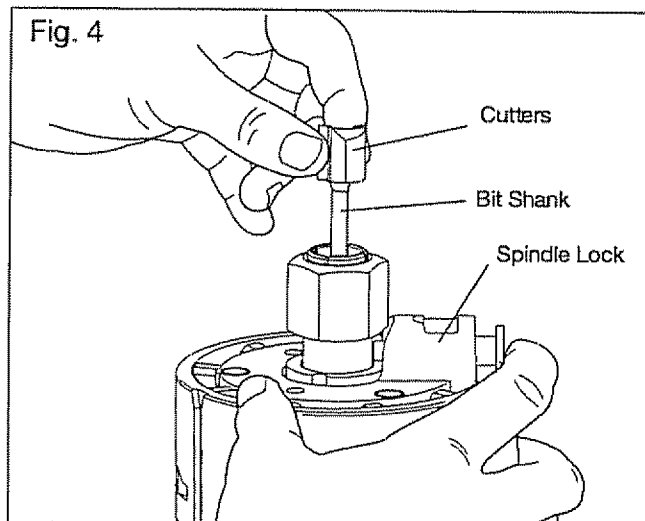
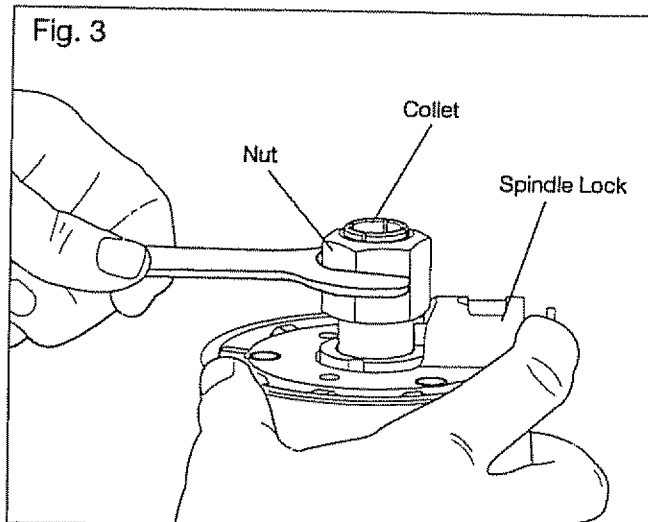

▲ WARNING: TIGHTEN COLLET/NUT SECURELY to prevent the cutting bit from slipping. If the collet/nut is not securely tightened, the cutting bit may detach during use, causing serious personal injury.

NOTE: To ensure proper gripping of cutting bit shank and minimize run-out, the shank of the cutting bit must be inserted into the collet/nut at least 5/8 inch.

▲ CAUTION: To prevent damage to tool, do not tighten collet/nut without a cutting bit installed.

REMOVING THE CUTTING BIT (Figs. 3 and 4 see page16)

1. Turn router motor off and unplug from power source.
2. Remove router motor from fixed base.
3. Set the router motor upside down on its top cap, with collet/nut pointing up.
4. Press spindle lock button to engage and lock the spindle shaft and collet/nut, (Fig. 3).
5. Place the wrench on the collet/nut and turn counterclockwise and loosen collet/nut slightly and remove cutting bit shank.

COLLET/NUT CARE

From time to time, inspect the collet/nut to make sure it is clean and is gripping the cutting bit properly. With the router cutting bit removed, turn the collet/nut counterclockwise (with spindle lock engaged) until it is free from router motor's spindle shaft.

Blow the collet out with compressed air, and clean the tapered inside of the collet/nut with a tissue or fine brush.

Always make sure the cutting bit shank, collet/nut and router motor spindle are clean and free of woodchips, dust, residue, grease and rust before installing.

Apply a slight amount of machine oil to spindle shaft if it looks dry.

Replace worn or damaged collets/nuts immediately.

NOTE: The collet/nut is self-releasing; it is NOT necessary to strike the collet/nut to free the router cutting bit. If cutting bit seems stuck after use, loosen collet/nut a little more until it releases.

CUTTING BITS

Get faster, more accurate cutting results by keeping cutting bits clean and sharp. Remove all accumulated pitch and gum from cutting bits after each use.

When sharpening cutting bits, sharpen only the inside of the cutting edge. Never grind the outside diameter. Be sure, when sharpening the end of a cutting bit, to grind the clearance angle the same as originally ground.

INSTALLING ROUTER MOTOR IN BASE

⚠ WARNING: NEVER use the router motor without installing it into either a fixed or plunge approved base. Failure to do so could result in serious personal injury and damage to router motor.

NOTE: Before installing router motor in fixed base, have the collet/nut and router cutting bit you are going to use already installed in router motor. See page 16 “INSTALLING AND REMOVING THE CUTTING BIT.”

⚠ WARNING: ALWAYS turn router motor off and unplug router from power source before making any adjustments or installing accessories. Failure to turn router motor off and unplug router could result in accidental starting which can cause serious personal injury.

INSTALLING ROUTER MOTOR IN BASE (Fig. 5)

1. Turn router motor off and unplug from power source.
2. Place fixed base on flat surface.
3. With back of fixed base facing you, open router motor clamp (A).
4. Press in Coarse Adjustment Knob (B) while you align the router motor's slot with the pin in the fixed base.
5. When the router motor's slot is aligned and engaged into the base's pin, slide the router motor down into the fixed base.
6. The router motor will now slide up or down to set coarse adjustments when the coarse adjustment knob is pressed in.
7. After all adjustments are made, close the router motor clamp securely.

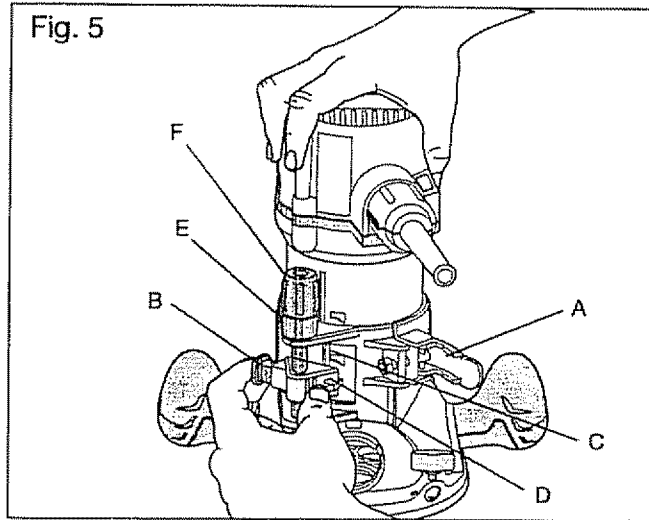

REMOVING ROUTER MOTOR FROM BASE (Fig. 5)

1. Turn router motor off and unplug from power source.
2. Place router (fixed base/router motor) on flat surface.
3. With back of router facing you, open the router motor clamp (A).
4. Push in coarse adjustment knob (B) to release router motor “Position groove” (C) from lock hook (D) in base, while you lift router motor free of base.
5. Set motor upside down on its top cap with collet pointing up and remove cutting bit. Store motor and base in carry bag when not being used.

▲ WARNING: ALWAYS remove cutting bits from collet/nut when the router is not being used. Leaving bits installed could result in an accident causing serious personal injury.

OPERATION

ADJUSTING DEPTH OF CUT

▲ WARNING: Your router should NEVER BE TURNED ON or be connected to the power source when you are assembling parts, making adjustments, installing or removing collets / nuts, cutting bits, cleaning or when it is not in use. Disconnecting the router will prevent accidental starting, which could cause serious personal injury.

NOTE: All depth adjustments on the Fixed Base must be made with the motor clamp open.

NOTE: For all Fixed Base Routers, the cutting bit depth equals the amount of the cutter that is exposed below the surface of the sub-base.

The fixed base is designed with a micrometer fine adjustment system. When the bit is lowered to the approximate position desired (coarse setting), the system then can be micro adjusted to the precise depth.

Coarse Adjustment:

Depressing the Coarse Adjustment Knob (B) allows you to quickly lower or raise the cutting bit to three depth settings.

Micro Adjustments:

NOTE: Before making fine adjustments, reset zero "0" on Depth Indicator Ring (E, Fig.5).

The Depth Indicator Ring (E, Fig.5) located on the Fine Adjustment Dial (F, Fig. 5) is marked incrementally in 64ths. Turning the fine adjustment dial clockwise 180° (1/2 turn), lowers the cutting bit 1/16 inch. One full turn clockwise (360°) zero "0" to zero "0" lowers the bit 1/8 in.

The Depth Indicator Ring may be reset to zero "0" without moving the Fine Adjustment Dial. This allows the user to begin adjustments from any reference point desired.

To Adjust Depth (Figs. 6 and 6a)

1. Turn router motor off and unplug from power source.
2. Place router on a flat, level surface with back of fixed base facing you. Open Router Motor Clamp (A).
3. With the cutting bit installed: press in the Coarse Adjustment Knob (B), lower the router motor in the base until the cutting bit is very close to the surface on which the base is sitting, and turn the Fine Adjustment Dial (F) until the cutting bit "just" touches the flat surface on which the base is sitting. Then lock the Router Motor Clamp (A).
4. While continuing to press the Coarse Adjustment Knob (B), turn the Fine Adjustment Dial (F) until ZERO "0" mark on Depth Indicator Ring (E) is lined up with the "I" mark on base.
5. Release the Coarse Adjustment Knob, making sure the "0" stays lined up with the mark.
6. Place the router on two level scrap work pieces, positioned so the cutting bit can be lowered below the sub-base.
7. Turn the Fine Adjustment Dial (F) counterclockwise to lower the bit to the desired depth of cut. Turn the dial clockwise to raise the cutting bit.
8. Once your depth of cut is set, close the router motor clamp (A) securely.

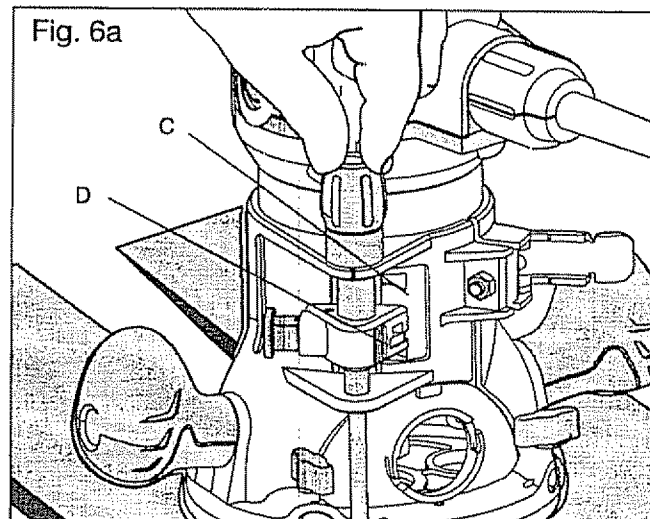
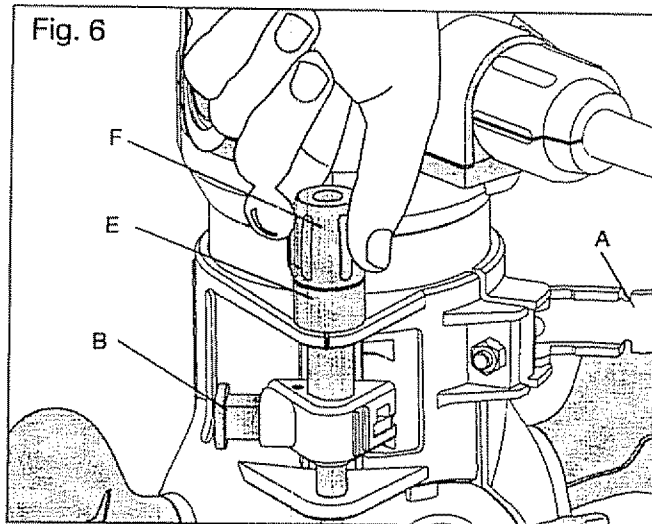

NOTE: Making a single deep cut is never advisable. Smaller diameter cutting bits are easily broken by too much side thrust and torque. Larger cutting bits will cause a rough cut and be difficult to guide and control. For these reasons, DO NOT EXCEED 1/8 in. DEPTH OF CUT in a single pass.

Deep Cuts

The proper cutting depth for each pass is always determined by the material, the cutting bit size and type, and the power of the router motor.

Always make several progressively deeper cuts by starting at one depth and then make several passes, each time increasing the cutting depth until your desired depth is reached.

Making a cut that is too deep will stress the router motor and the cutting bit, and it may burn the work piece and dull the cutting bit. It could also “grab” too much of the work piece and cause you to lose control of the router, causing a serious accident.

To be certain that your depth settings are as desired, always make test cuts in scrap material similar to your work piece before beginning your final cutting.

Remember, knowing the right depth for each cut comes with routing experience.

TOGGLE “ON/OFF” SWITCH (Fig. 7)

Your router motor is turned “ON” and “OFF” by the toggle switch located on the top cap of the router motor.

The left side of the toggle switch hood (as you face it) is marked “I” for “On” and the right side (as you face it) is marked “O” for “Off.”

TO TURN THE ROUTER MOTOR “ON,” Push the toggle switch to the left side marked “I,” or “On.”

TO TURN THE ROUTER MOTOR “OFF” Push the toggle switch to the right side marked “O,” or “Off.”

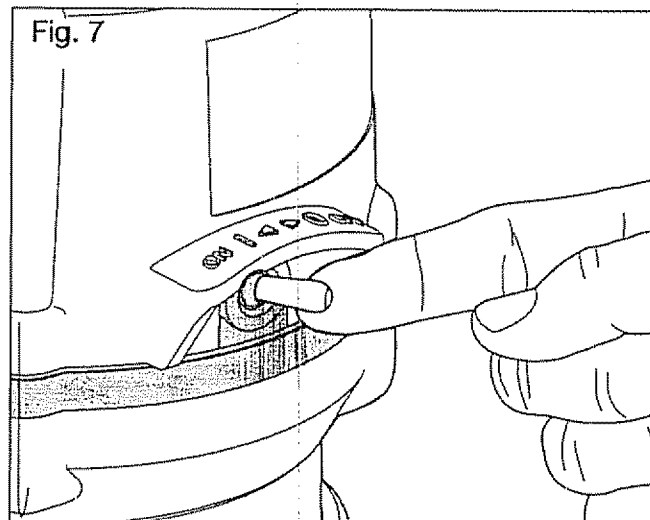

When turning the toggle switch “On,” always support one edge of the router base on the work piece while holding the cutting bit away from the work piece. Only contact the work piece with the cutting bit after the router has reached full speed. ONLY remove the router and cutting bit from the work piece AFTER turning the router motor “OFF,” and the cutting bit has come to a complete stop.

Operating in this manner will increase toggle switch and motor life, and will increase the quality of your work.

SOFT START FEATURE

Electronic feedback control minimizes torque twist, customary in larger router motors, by limiting the speed at which the router motor starts. This increases the motor’s life.

LED WORKLIGHTS (Fig. 8)

Your router motor has 3 built-in work lights located around the collet/nut to provide high visibility of work piece when cutting. These lights are always "On" when the toggle switch is in the "On" position.

"LIVE TOOL INDICATOR" LIGHT (Fig. 9)

Your router also has a "LIVE TOOL INDICATOR" green light, located on the router motor top cap where the power cord enters the router motor. This green light is always on when router motor is plugged into power source.

HEAVY-DUTY EDGE GUIDE (Fig. 10)

Your Fixed Base Router comes with a Heavy-Duty Edge Guide. This edge guide can be used as an aid in routing applications such as decorative edging, straight-edge planing and trimming, grooving, dadoing and slotting.

To assemble onto fixed or plunge bases, simply insert edge guide rods into edge guide mounting slots, adjust to desired position, and lock down with the edge guide locking knobs.

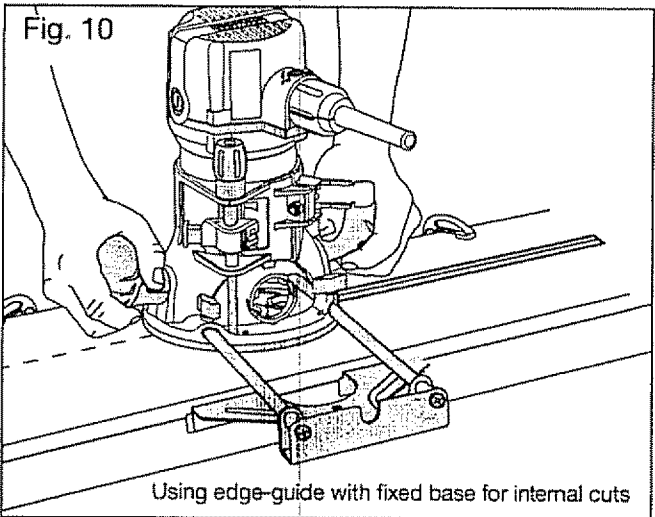
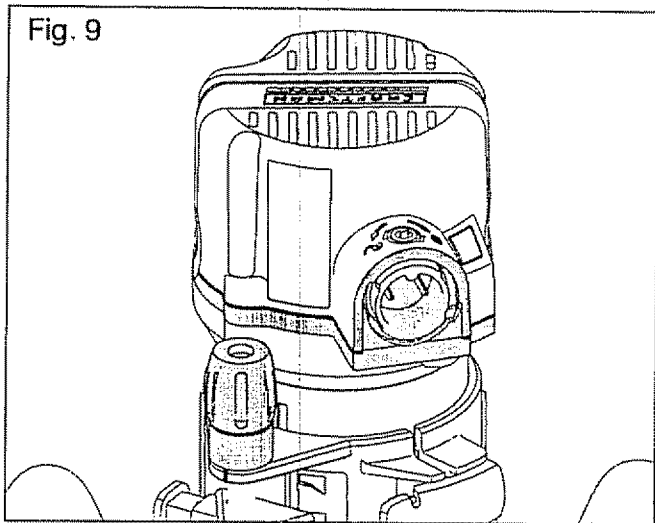
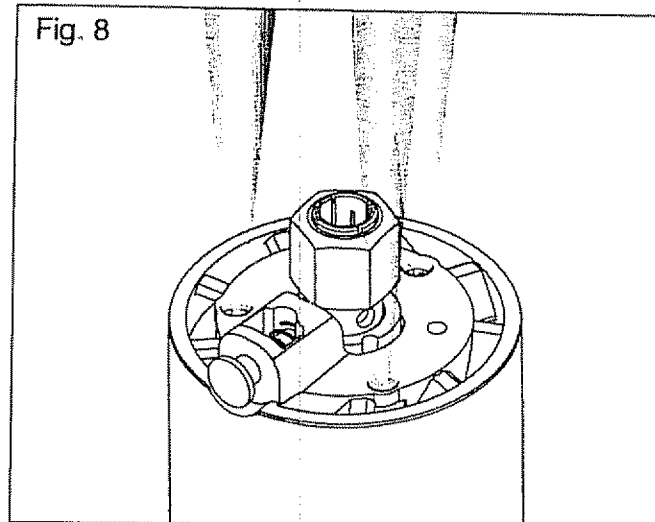

DETACHABLE POWER CORD (Fig. 11)

The router has a detachable power cord for easy carrying and storage.

Note: Always attach the Detachable Power Cord to the Router before connecting the Power Cord to the power source

Before turning the router on, connect the end of the power cord with two sockets to the power outlet located on the router motor's top cap (See indicator label on the Router).

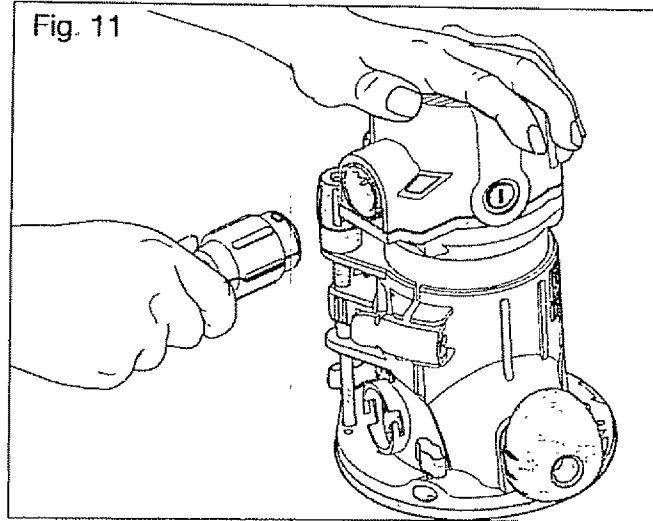

Electronic Variable Speed Control

The electronic speed control feature allows router motor speed to be matched to cutter size and material hardness for an improved finish and extended bit life.

Variable Speed Selection Chart	
Never exceed these bit speeds	
Cutting Bit Diameter	Max. Speed
Up to 1 in. (25mm)	6
1-1/4 in. to 2 in. (30-50mm)	4 - 5
2-1/4 in. to 2-1/2 in. (55-65 mm)	2 - 3
3 in. to 3-1/2 in. (75-90mm)	1 - 2

Reduce the speed when using extra large 1 in. plus, or heavy cutting bits. Changing the router's rate of feed can also improve the quality of the cut.

DIAL SETTING	RPM	APPLICATION
1	12,000	Non-ferrous metal, hardwoods, larger diameter cutting bits
2	14,000	
3	16,000	
4	18,000	Softwoods, plastics, countertops, smaller diameter cutting bits
5	20,000	
6	25,000	

The speed charts above indicate the relationship between speed settings and the cutting application. Exact settings are determined by operator experience and preference, and also by recommendations by manufacturers of cutting bits.

ELECTRONIC FEEDBACK CIRCUITRY

The router's electronic feedback circuitry monitors and adjusts power to maintain the desired RPM for consistent performance and control, providing constant speed under load for a quality finish in all materials

PLACING THE ROUTER ONTO THE WORKPIECE AND STARTING THE CUT

⚠ WARNING: Before operating your router follow all safety instructions in this manual. Failure to do so could result in serious personal injury.

NOTE: Making test cuts is essential with most routing applications. Even with careful set-ups you won't know exactly how the cut will go until you try it out. A test cut will give you a feel for the set-up, the router's speed, the depth of cut and how the cutting bit reacts to the work piece. Much of routing is a trial-and-error process of making various adjustments, followed by test cuts as you become familiar with all of your router's operational abilities. To avoid ruining good material, make your test cuts on scrap materials.

How you place your router onto a work piece to start the cut depends on the type of routing you are going to perform: Edge Routing or Internal Routing.

EDGE ROUTING OR INTERNAL ROUTING

For ease of operation and to maintain proper control, your router has two handles, one on each side of the router base. When operating the router, always hold it firmly with both hands (Fig. 12).

Turn the router "On," let the router motor build to its full speed, then gradually feed the cutting bit into the work piece. **ALWAYS** be alert and watch what you are doing. **NEVER** operate the router when you are fatigued.

EDGE ROUTING (Fig. 12)

1. With depth-of-cut set, place router on edge of work piece, making sure the cutter does not contact the work piece.
2. Have an edge guide (board or metal straightedge) clamped in place to help guide router's base when making your edge cut.
3. Turn the router "On," and let the router motor build to its full speed.
4. To begin your cut, gradually feed the cutting bit into the edge of the work piece.

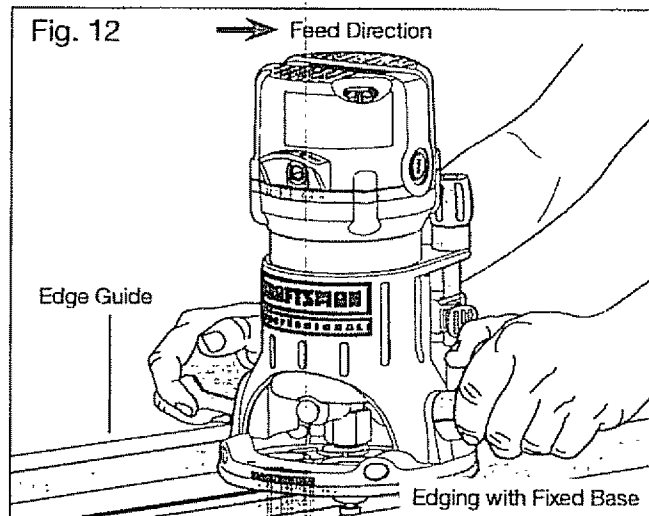

5. When cut is completed, turn router motor "Off" and let cutting bit come to a complete stop before removing it from the work piece.
6. Unplug router from power source, place router upside down on worktable, and inspect finished cut in work piece.

▲ WARNING: Always securely clamp your work piece and keep a firm grip on the router base with **BOTH HANDS** at all times. Failure to do so could result in loss of control causing possible serious personal injury.

▲ WARNING: Removing cutting bit from work piece while it is still rotating could damage work piece and result in loss of control, causing serious personal injury.

NOTE: Making test cuts in scrap material that is similar to your work piece is essential. Learning how the router's speed, depth-of-cut and cutting bit will react in the work piece will help you produce quality cuts.

INTERNAL ROUTING (Figs. 13, 13a, 13b)

1. With depth-of-cut set, tilt router and place on work piece with leading edge of sub-base contacting work piece first (Fig.13).
2. Turn router motor "On" and let motor build up to its full speed, being careful not to let cutting bit contact work piece.
3. To begin your cut, gradually feed the cutting bit into the work piece until the sub-base is level with the work piece (see Fig 13a, 13b).

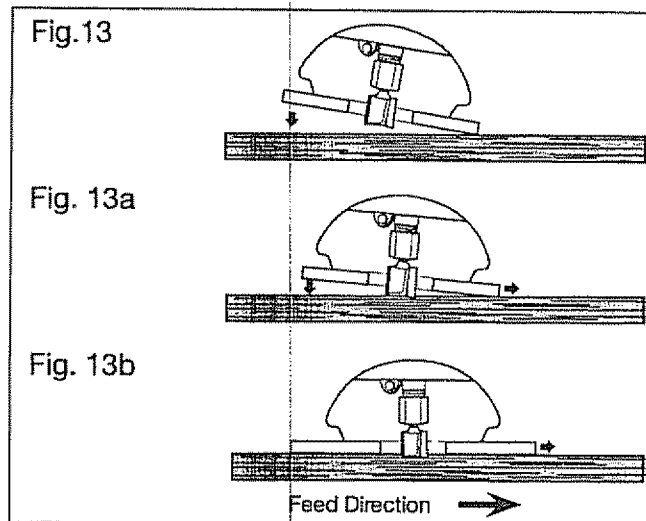

4. When cut is completed, turn motor "Off" and let cutting bit come to a complete stop before removing it from the work piece.
5. Unplug router from power source, place router upside down on worktable, and inspect finished cut in work piece.

▲ WARNING: Removing cutting bit from work piece while it is still rotating could damage work piece and result in loss of control, causing serious personal injury.

FREEHAND ROUTING WITH THE FIXED BASE (Fig. 14)

⚠ WARNING: Do not use large cutting bits for freehand routing. Use of large cutting bits when freehand routing could cause loss of control or create other hazardous conditions that could result in personal injury. If using a router table, large bits should be used for edging only.

When used freehand, the router becomes a flexible and versatile tool. This flexibility makes it possible to easily rout signs, relief sculptures, etc. When freehand routing:

1. Draw or layout the pattern on the work piece.
2. Choose the appropriate bit.
3. Rout the pattern in two or more passes. Do not exceed 1/8 in. depth of cut in a single pass. This will help provide better control as well as serve as a guide on the next passes.

NOTE: A core box or V-groove bit is often used for routing letters and engraving objects. Straight bits and ball mills are often used to make relief carvings. Veining bits are used to carve small, intricate details.

NOTE: Making a single deep cut is never advisable. Smaller diameter bits are easily broken by too much side thrust and torque. Larger bits will cause a rough cut and be difficult to guide and control. For these reasons, **DO NOT EXCEED 1/8 in. DEPTH OF CUT** in a single pass.

⚠ WARNING: Always securely clamp your work piece and keep a firm grip on the router base with **BOTH HANDS** at all times. Failure to do so could result in loss of control causing possible serious personal injury.

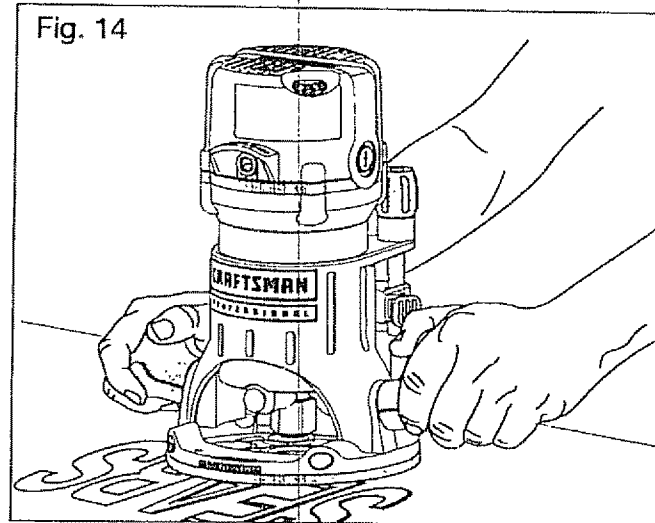

EDGING WITH A PILOT BIT (Figs. 15 and 15a)

Arbor-type bits with pilots are excellent for edge shaping any work-piece edge that is straight or is curved at a curvature that is equal to or greater than the bit radius.

The pilot prevents the bit from making too deep a cut. Holding the pilot firmly in contact with the work-piece edge prevents the cut from becoming too shallow.

Used when the thickness of the work piece and the depth of cut are such that only the top part of the edge is shaped, and at least 1/16 in. of the lower part of the work piece remains uncut, the pilot rides against and is guided by the uncut portion (Fig. 15).

An extra board must be placed under the work piece to act as a guide if less than 1/16-inch of the work piece would otherwise remain uncut-either because the work piece is too thin or the bit is set too low (see Fig. 15a).

This guide board must have exactly the same contour - straight or curved - as the work-piece edge. If the guide board is positioned so that it extends from the work piece, the bit will make less than a full cut, which will alter the shape of the finished edge

NOTE: The size (diameter) of the pilot determines the maximum cut width that can be made (the small pilot exposes all of the bit; the large one reduces this amount by 1/16 in.). Any of the piloted cutting bits can be used without a pilot, but with a guide, for edge shaping.

▲ WARNING: Always securely clamp your work piece and keep a firm grip on the router base with **BOTH HANDS** at all times. Failure to do so could result in loss of control causing possible serious personal injury.

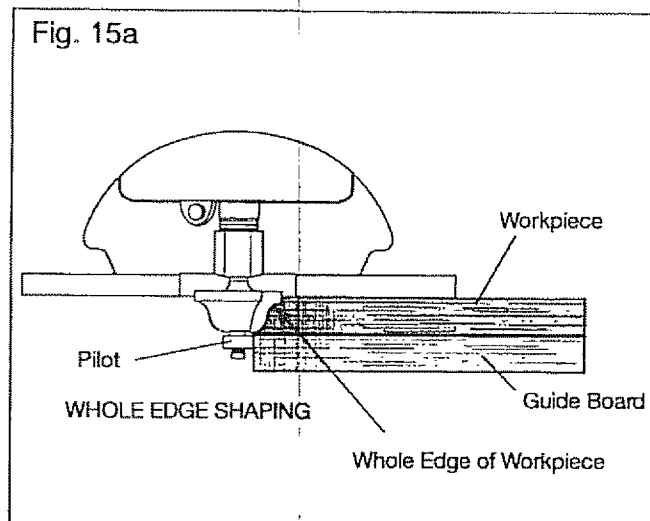
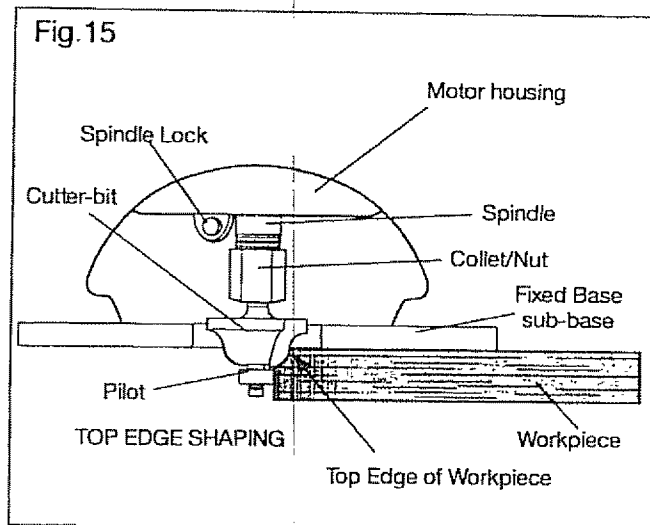

FEEDING THE ROUTER (Fig. 16)

The secret to professional routing is in making a careful set-up for the cut, selecting the proper depth of cut, knowing how the cutting bit reacts in your work piece, and the rate and direction of feed of the router.

DIRECTION OF FEED - EXTERNAL CUTS (Fig. 16)

The router motor and cutting bit rotate clockwise. This requires the feed of the cutting bit to be from left to right (see Fig. 16). Feeding the bit from

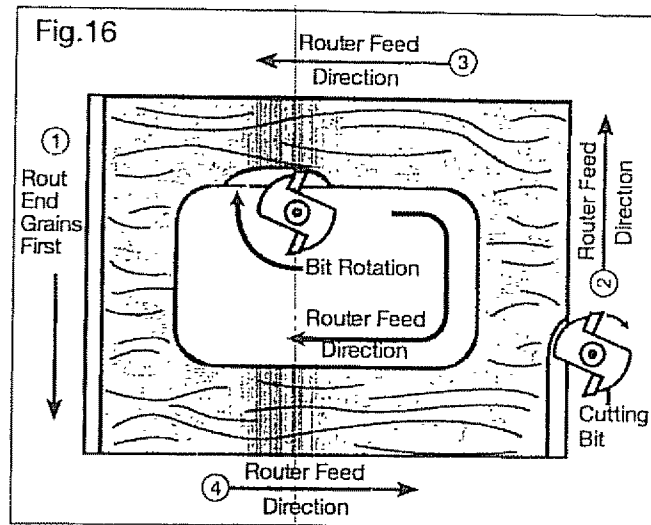

left to right will cause the bit to pull the router towards (up against) the work piece

If you feed the router in the opposite direction (right to left), the rotating force of the cutting bit will tend to throw the bit away from the work piece, making it hard to control; this is called Climb-Cutting, which is cutting in the opposite direction of the proper feed direction. Climb Cutting increases the chance for loss of control, possibly resulting in personal injury. When Climb Cutting is required (backing around a corner for example), exercise extreme caution to maintain control of the router.

Because of the high speed of the cutting bit during a proper feeding operation (left to right), there is very little kickback under normal conditions. However, if the cutting bit strikes a knot, an area of hard grain in the wood work piece, or a foreign object, the normal cutting action could be affected and cause "Kickback."

This Kickback may cause damage to your work piece, and could cause you to lose control of the router, causing possible personal injury. Kickback is always in the opposite direction of the clockwise cutting bit rotation, or counterclockwise.

To guard against and help prevent Kickback, plan your set-up and direction of feed so you're always moving the router, keeping the sharp edges of the cutting bit continuously biting straight into new (uncut) wood (work piece). Also, always inspect your work piece for knots, hard grain, and foreign objects that could cause a kickback problem.

DIRECTION OF FEED - INTERNAL CUTS (Figs. 17 and 17a)

When making an internal cut, such as a groove, dado or slot, always have the guide you are using with the router (edge guide, straight edge, board guide), on the right-hand side of the router as you make your cut, see Fig. 17).

When the guide is positioned on the right hand side of the router, the router travel should be from left to right and “counterclockwise” around curves (see Fig. 17). This counterclockwise action around the curve could cause **Climb Cutting**. Always be alert and exercise extreme caution to maintain control of the router when making this type of cut around curves.

When the guide is positioned as shown in Fig. 17a, the router travel should be from left to right and clockwise around curves.

If there is a choice, the set-up in Fig. 17 is easier to use, but there is the possibility of **Climb Cutting** around curves. In either case, Fig. 17 or Fig. 15a, the sideways thrust of the router cutting is always against the guide, as is proper.

⚠ WARNING: Always securely clamp your work piece and keep a firm grip on the router base with **BOTH HANDS** at all times. Failure to do so could result in loss of control causing possible serious personal injury.

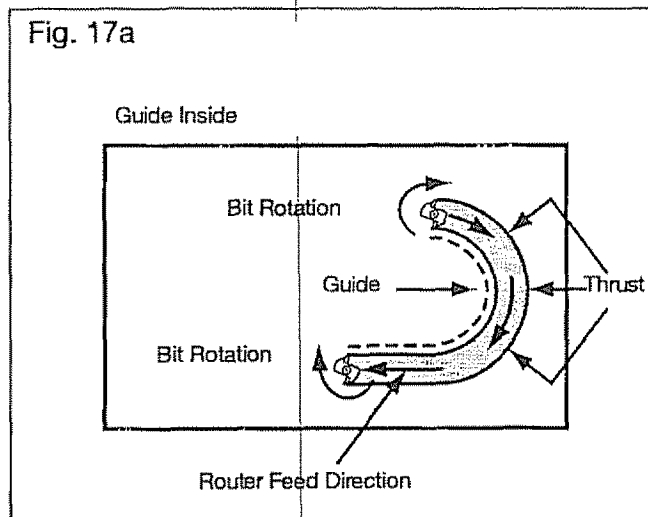
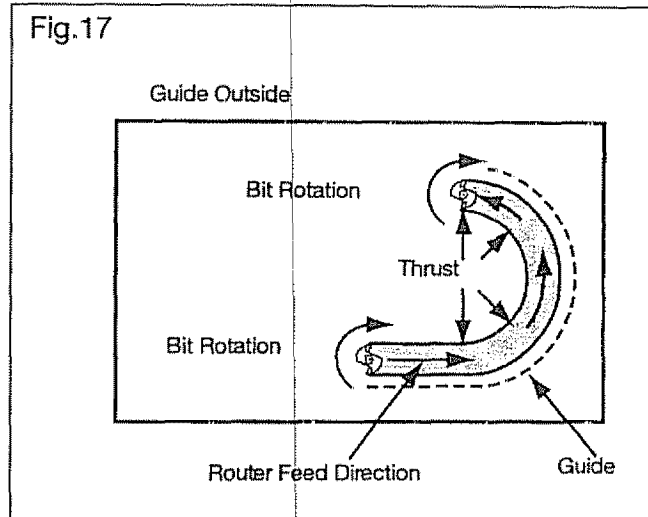

RATE OF FEED (Figs. 18 and 18a)

The proper rate of feed depends on several factors: the hardness and moisture content of the work piece, the depth of cut, and the cutting diameter of the bit. When you are cutting shallow grooves in soft woods such as pine, you may use a faster rate of feed. When making deep cuts in hardwoods such as oak, you should use a slower rate of feed.

FEEDING TOO FAST (Fig. 18)

Clean and smooth finished cuts can only be achieved when the cutting bit is rotating at a relatively high speed, taking very small bites, producing tiny, clean cut chips.

Forcing the feed of the cutting bit forward too fast slows the RPM of the cutting bit, and the bit takes bigger bites as it rotates. Bigger bites mean bigger chips and a rough finish. This forcing action can also cause the router motor to overheat.

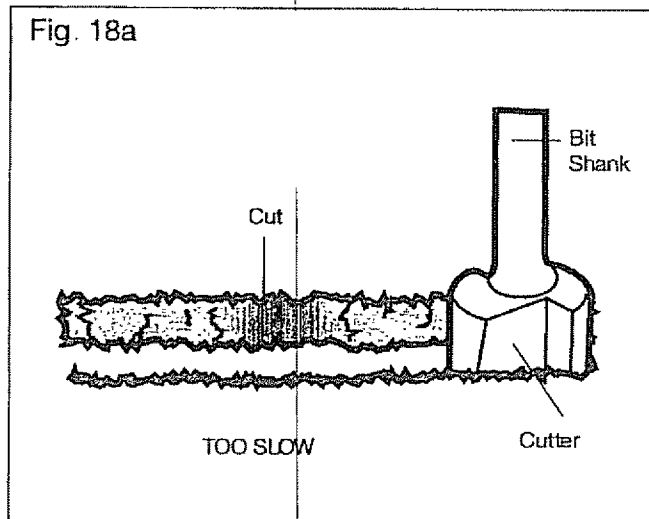
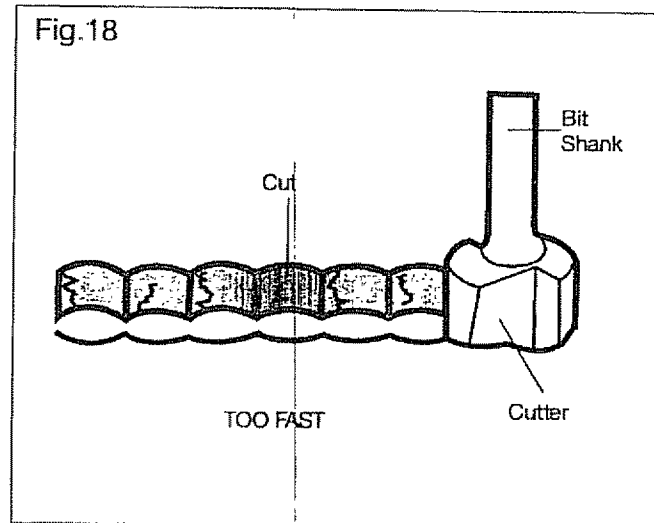

Under extreme force-feeding conditions, the RPMs can become so slow and the bites become so large that chips become partially cut off, causing splintering and gouging of the work piece.

The router will make clean, smooth cuts if allowed to run freely without the overload of forced feeding. You can detect forced feeding by the sound of the motor. Its usual high-pitched whine will sound lower and stronger as it loses speed. Holding the router against the work piece will also be strained and harder to do.

FEEDING TOO SLOW (Fig. 18a)

When you feed the cutting bit too slowly, the rotating cutting bit does not cut into new wood fast enough to take a bite. Instead, it scrapes away sawdust-like particles. This scraping produces heat, which can glaze, burn and mar the cut in the work piece and, in extreme cases, overheat the cutting bit.

When the cutting bit is scraping instead of cutting, the router is more difficult to control as you feed it.

With almost no load on the router motor, the cutting bit has a tendency to bounce off the sides of the cut in the work piece, producing a cut with a rippled finish instead of clean straight sides.

CHIP SHIELD DEFLECTOR (Fig. 19)

⚠ WARNING: ALWAYS wear eye protection. The chip shield deflector is not intended as a safety guard.

To remove chip shield from fixed base, press inward on tabs until chip shield releases from base and remove it. To attach, place chip shield back in position and flex sides while pushing it in until it snaps back into place (See Fig. 19).

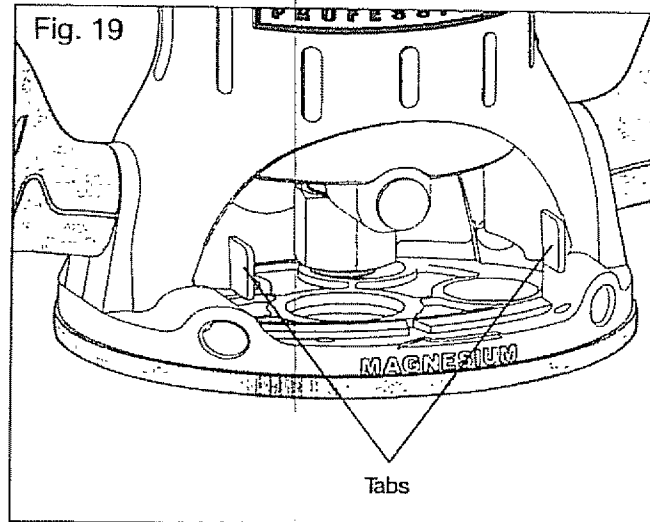

⚠ WARNING: The chip shield deflector helps keep dust and chips away from the operator; it will not stop objects larger than woodchips thrown from the bit.

CAUTION: ALWAYS have the chip shield deflector in place on the base when operating the router.

⚠ WARNING: ALWAYS turn router motor off and unplug router from power source before making any adjustments or installing accessories. Failure to turn router motor off and unplug router could result in accidental starting which can cause serious personal injury.

DUST COLLECTION WITH DUST EXTRACTION ADAPTER (Fig. 20)

There is a dust extraction hood included with this router. The hood is sized to accept a 1-1/4 in. vacuum hose adapter, sold separately.

To attach the adapter onto the fixed base, align two tabs on the adapter with two slots on the port at back of the base, and secure it by turning clockwise shown in Fig. 20.

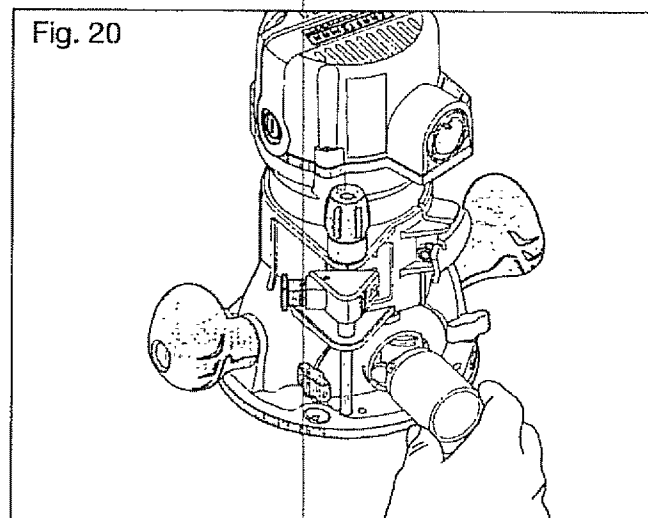

To adjust Depth with the Depth-Adjustment Wrench (Fig. 21)

NOTE: The Depth-Adjustment Wrench supplied is used to adjust the depth of cut when the router fixed to the router table (Model No. 320, 28180).

The bit depth can be adjusted by turning the Micro Adjustment Dial clockwise or counterclockwise with the wrench supplied. The depth of the cut can be read on the scale dial. Each mark on the scale indicates a 1/64 in. change in depth setting.

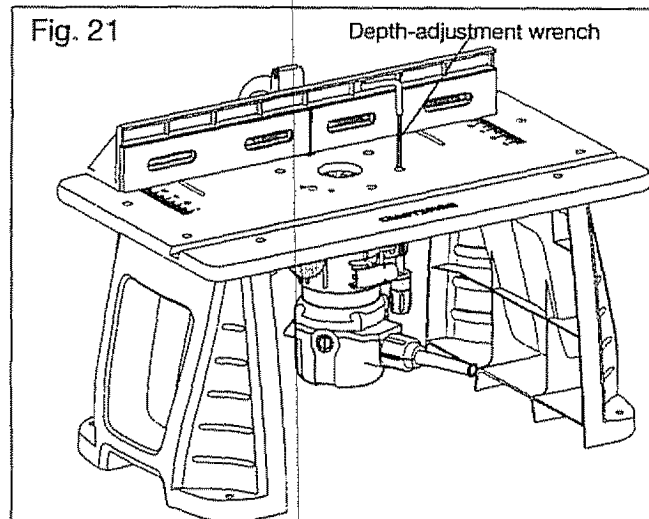

1. Switch off the router.
2. Loosen the router motor clamp.
3. Insert the wrench into the adjusting hole on the table top, turn the adjustment knob clockwise with the wrench to move the collet down, or counterclockwise to move the collet up.
4. When the desired depth of cut is set, tighten the clamping lever.

MAINTENANCE

⚠ WARNING: To ensure safety and reliability, all repairs should be performed by a qualified service technician at a Sears Service Center.

GENERAL

Only the parts shown on the parts list are intended for repair or replacement by the customer. All other parts represent an important part of the double insulation system and should be serviced only by a qualified Sears service technician.

⚠ WARNING: For your safety, ALWAYS turn off switch and unplug router motor from the power source before performing any maintenance or cleaning.

It has been found that electric tools are subject to accelerated wear and possible premature failure when they are used to work on fiber glass boats and sports cars, wallboard, spackling compounds or plaster. The chips and grindings from these materials are highly abrasive to electrical tool parts, such as bearings, brushes, commutators, etc. Consequently, it is not recommended that this tool be used for extended work on any fiberglass material, wallboard, spackling compound or plaster. During any use on these materials, it is extremely important that the tool is cleaned frequently by blowing with an air jet.

⚠ WARNING: Always wear safety goggles or safety glasses with side shields during power tool operations, or when blowing dust. If operation is dusty, also wear a dust mask.

ROUTINE MAINTENANCE

⚠ WARNING: DO NOT at any time let brake fluids, gasoline, petroleum-based products, penetrating oils, etc. come in contact with plastic parts. Chemicals can damage, weaken or destroy plastic, which may result in serious personal injury.

- When work has been completed, clean the tool to allow smooth functioning of the tool over time.
- Use clean damp cloths to wipe the tool.
- Check the state of all electrical cables.
- Keep the router motor air openings free from oil, grease and sawdust or woodchips, and store tool in a dry place.
- Be certain that all moving parts are well lubricated, particularly after lengthy exposure to damp and/or dirty conditions.

⚠ WARNING: For your safety, ALWAYS turn off switch and unplug router motor from the power source before performing any maintenance or cleaning.

Refer to Collet/Nut Care and Cutting Bits on page 17 for cleaning and care.

REPLACEMENT OF CARBON BRUSHES (Fig. 22)

Replacement brush sets are available through Sears Parts and Repair Centers.

1. Unplug the router motor before inspecting or replacing brushes.
2. Replace both carbon brushes when either has less than 1/4 in. length of carbon remaining, or if the spring or wire is damaged or burned.
3. Using a slotted screwdriver, remove the black plastic cap on each side of the router motor (Fig. 22) and carefully withdraw the spring-loaded brush assemblies. Keep brushes clean and sliding freely in their guide channels.

NOTE: To reinstall the same brushes, make sure the brushes go back in the same way they came out. This will avoid a break-in period.

4. Insert new brush assemblies into guide channels, with the carbon part going in first, being certain to fit the two metal "ears" into their slots in the channel (Fig. 22).
5. Remember to replace both end caps after inspecting or servicing brushes. Tighten the caps snugly, but do not over-tighten. The router should be allowed to "RUN IN" (run at no load without a cutting bit) for 5 minutes before use, to seat the new brushes properly.

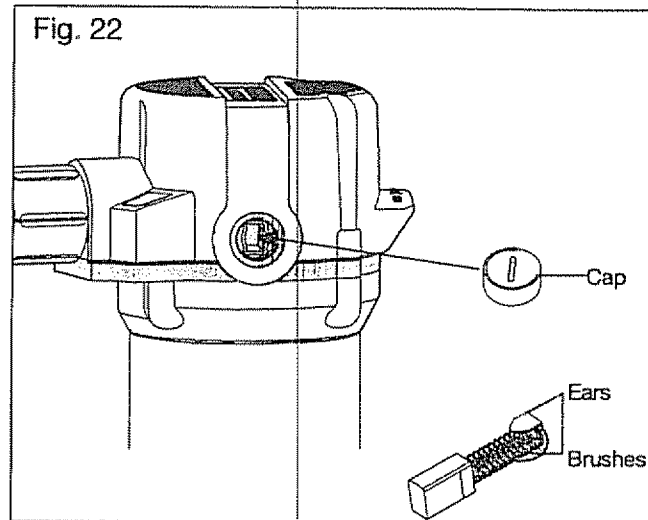

⚠ WARNING: For your safety, ALWAYS turn off switch and unplug router motor from the power source before performing any maintenance or cleaning.

LUBRICATION

All of the bearings in this tool are lubricated with a sufficient amount of high-grade lubricant for the life of the tool under normal operating conditions. Therefore, no further lubrication is required.

TROUBLESHOOTING

Trouble	Probable Cause	Solution
<ul style="list-style-type: none"> •The router does not work 	<ul style="list-style-type: none"> •Plug is not plugged into the power source. 	<ul style="list-style-type: none"> •Plug the detachable cord into the power source.
	<ul style="list-style-type: none"> •Plug is not plugged into the Router socket. 	<ul style="list-style-type: none"> •Plug the detachable cord into the Router.
	<ul style="list-style-type: none"> •Switch is in "OFF" position. 	<ul style="list-style-type: none"> •Pull the switch to "ON" position.
	<ul style="list-style-type: none"> •The carbon brushes have worn out completely. 	<ul style="list-style-type: none"> •Open the brush cap, and replace the old brushes with suitable new brushes.
<ul style="list-style-type: none"> •The surface of the work piece is not smooth 	<ul style="list-style-type: none"> •The bit is dull. 	<ul style="list-style-type: none"> •Change to a sharp bit.
	<ul style="list-style-type: none"> •Routing at an inappropriate bit speed. 	<ul style="list-style-type: none"> •Refer to "Variable Speed Selection Chart" label on the Router Motor cap, and select an appropriate bit speed.
<ul style="list-style-type: none"> •Bit can not be installed 	<ul style="list-style-type: none"> •Bit size is inappropriate for the collet 	<ul style="list-style-type: none"> •Use only 1/2 in. or 1/4 in. diameter bits.

ACCESSORIES

⚠ WARNING: The use of attachments or accessories that are not recommended for this tool might be dangerous and could result in serious injury.

Sears and other Craftsman outlets offer a large selection of Craftsman router accessories designed for specific routing applications.

There is a large selection of Craftsman Router Cutting Bits available in High-Speed Steel or Carbide Tipped High-Speed Steel for all your routing needs.

In addition to a wide variety of router bits, Sears also offers accessories such as: Router tables, various template sets, universal router fence with lock knobs (64181), 11 pc. bushing set (64180) and clear sub-base sets; 6pc. fixed base (64182) 6 pc. plunge base (64183).

⚠ WARNING: Only use router tables with proper guarding for the cutting bit and with "on-board" switch controlled receptacles. Failure to use router tables with appropriate safety features could result in serious personal injury.

PARTS LIST

12.5 Amp / Variable Speed / 2-1/4 Peak HP Fixed Base Router MODEL NUMBER 320.28190

The Model Number will be found on the Nameplate.

Always mention the the tool's model number when ordering parts.

Accessories

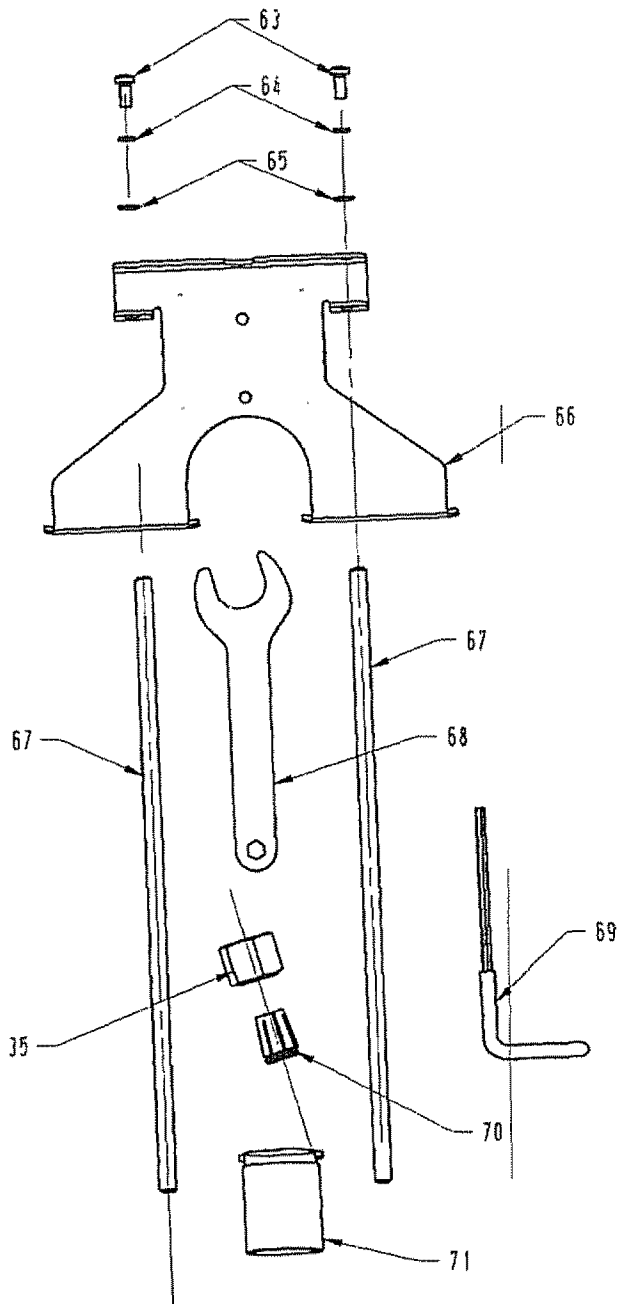

PARTS LIST

12.5 Amp / Variable Speed / 2-1/4 Peak HP Fixed Base Router MODEL NUMBER 320.28190

The Model Number will be found on the Nameplate.

Always mention the tool's model number when ordering parts.

Fixed Base

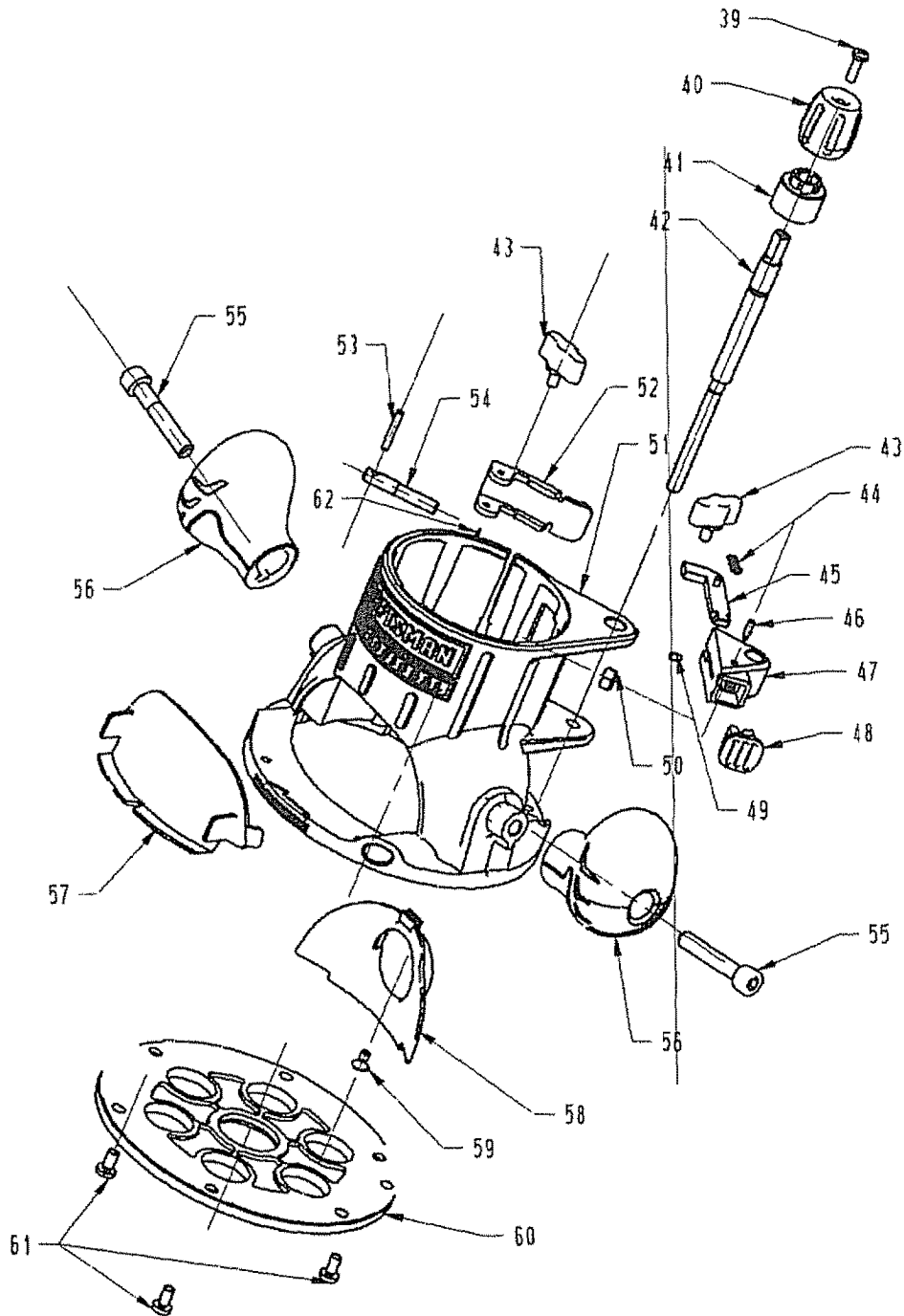

PARTS LIST

12.5 Amp / Variable Speed / 2-1/4 Peak HP Fixed Base Router MODEL NUMBER 320.28190

The Model Number will be found on the Nameplate.

Always mention the the tool's model number when ordering parts.

Router Motor Unit

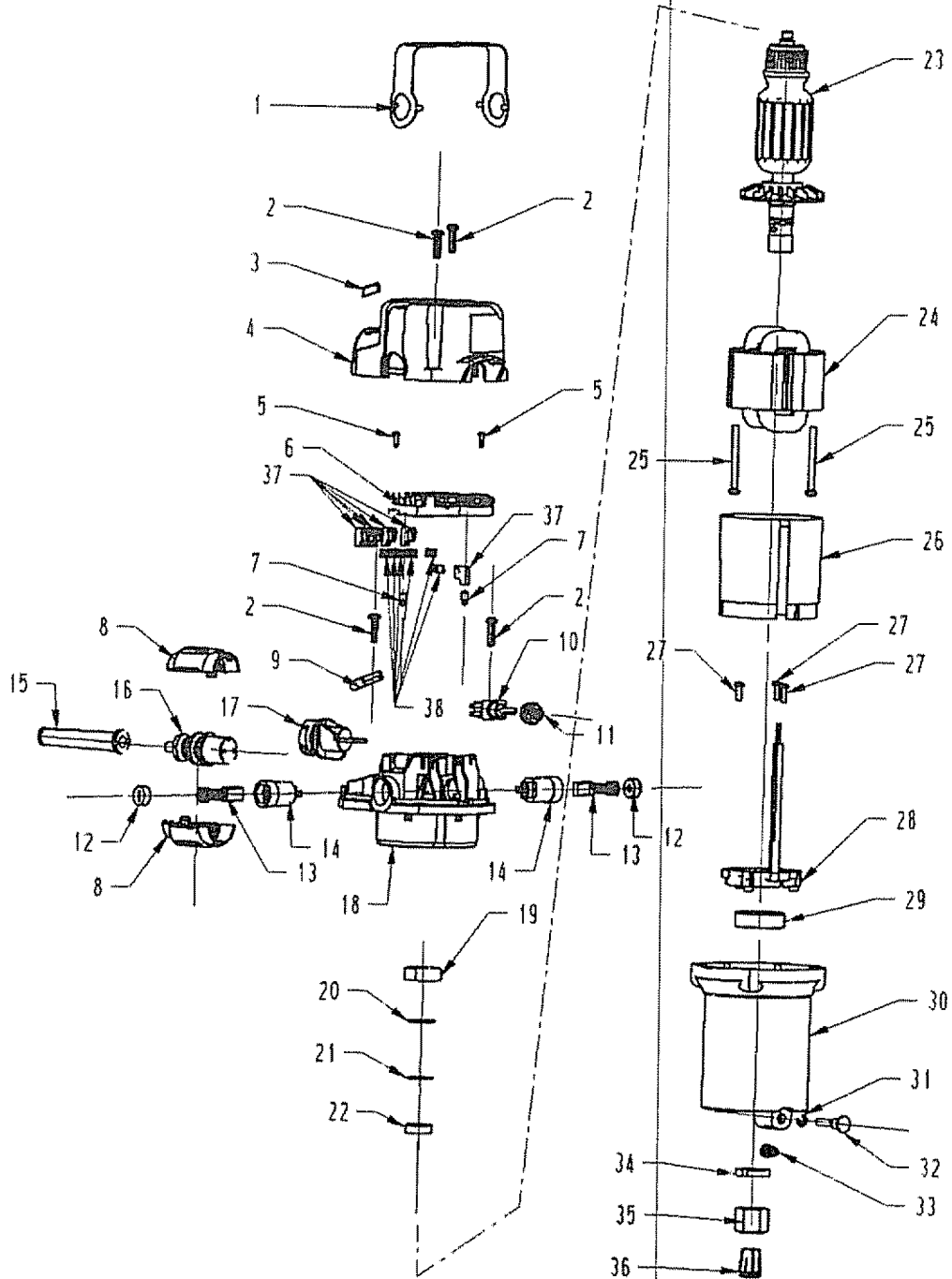

PARTS LIST

12.5 Amp / Variable Speed / 2-1/4 Peak HP Fixed Base Router MODEL NUMBER 320.28190

The Model Number will be found on the Nameplate.

Always mention tool's model number when ordering parts.

No.	Part No.	Part Name	Quantity
1	3703841000	Decorate Cover	1
2	5610059000	Screw	4
3	3123313000	Transparent Cap	1
4	3123278000	Rear Cover	1
5	5610017000	Screw	2
6	4900256000	PCB Plate	1
7	5620017000	Screw	2
8	3123329000	Lock Ring	2
9	4540017000	Power Indicator Light	1
10	4870073000	Switch	1
11	3122851000	Seal Ring	1
12	3120537000	Brush Cap	2
13	4960019000	Carbon Brush	2
14	2800005000	Brush Holder	2
15	3121064000	Cord Guard	1
16	2822257000	Power Cord ASSY	1
17	4930314000	Receptacle	1
18	3123279000	Middle Housing	1
19	3520130000	Bearing Holder	1
20	3121049000	Gasket	1
21	3700249000	Gasket	1
22	5700008000	Bearing	1
23	2750839000	Rotor	1
24	2740240000	Stator	1
25	5610100000	Screw	2
26	3123280000	Fan Baffle	1

No.	Part No.	Part Name	Quantity
27	5620040000	Screw	3
28	2822255000	LED Holder ASSY	1
29	5700056000	Bearing	1
30	3420557000	Router Motor	1
31	5660005000	"E" Ring	2
32	3550855000	Spindle Lock	1
33	3660174000	Stop Spring	1
34	5630179000	Nut	1
35	5630187000	Collet Nut	2
36	3550721000	Collet	1
37	4930008000	Sleeve	6
38	4930038000	Receptacle	6
39	5620041000	Screw	1
40	3320460000	Adjusting Knob	1
41	3123281000	Indicator	1
42	3550854000	Shaft	1
43	3400189000	Lock Bolt	2
44	3660293000	Spring	1
45	3520259000	Sliding Block	1
46	5620057000	Screw	1
47	3420562000	Adjustor Block	1
48	3123282000	Button	1
49	5670040000	Located Pin	1
50	5630015000	Lock Nut	1
51	3420558000	Mounting	1
52	3703863000	Clamping Lever	1
53	5670026000	Pin	1
54	3550577000	Mitre Lock Bolt	1
55	5620024000	Screw	2
56	3320274000	Handle	2
57	3121637000	Chip Shield	1
58	3123294000	Dust Bracket	1
59	5620067000	Screw	1

No.	Part No.	Part Name	Quantity
60	3122924000	Mounting Plate	1
61	5620049000	Screw	3
62	3703872000	Plate	1
63	5620050000	Screw	2
64	5650015000	Spring Washer	2
65	5650013000	Plain Washer	2
66	3703925000	Fence	1
67	3550588000	Guiding Rod	2
68	3700807000	Wrench	1
69	3402220000	Depth Adjusting Lever	1
70	3550595000	Collet	1
71	3123286000	Vaccum Adapter	1

Get it fixed, at your home or ours!

Your Home

For expert troubleshooting and home solutions advice:

manage  home

www.managemyhome.com

For repair – **in your home** – of **all** major brand appliances, lawn and garden equipment, or heating and cooling systems, **no matter who made it, no matter who sold it!**

For the replacement parts, accessories and owner's manuals that you need to do-it-yourself.

For Sears professional installation of home appliances and items like garage door openers and water heaters.

1-800-4-MY-HOME® Call anytime, day or night
(1-800-469-4663) (U.S.A. and Canada)
www.sears.com www.sears.ca

Our Home

For repair of carry-in items like vacuums, lawn equipment, and electronics, call anytime for the location of the nearest **Sears Parts & Repair Service Center**

1-800-488-1222 (U.S.A.) **1-800-469-4663** (Canada)
www.sears.com www.sears.ca

To purchase a protection agreement on a product serviced by Sears:

1-800-827-6655 (U.S.A.) **1-800-361-6665** (Canada)

Para pedir servicio de reparación a domicilio, y para ordenar piezas:

1-888-SU-HOGAR®
(1-888-784-6427)

Au Canada pour service en français:

1-800-LE-FOYER^{MC}
(1-800-533-6937)
www.sears.ca

Sears

© Sears Brands, LLC

® Registered Trademark / TM Trademark / SM Service Mark of Sears Brands, LLC

® Marca Registrada / TM Marca de Fábrica / SM Marca de Servicio de Sears Brands, LLC

^{MC} Marque de commerce / ^{MD} Marque déposée de Sears Brands, LLC