

MODELS 158.13400, .1340180
 153.13450, .1345180
 158.13500, .1350180
 158.1355080

STRAIGHT STITCH POSITION	ATTACHMENT DIMENSION	ZIGZAG BITE
CENTER	LOW BAR	5.0

PRESSER FOOT HEIGHT

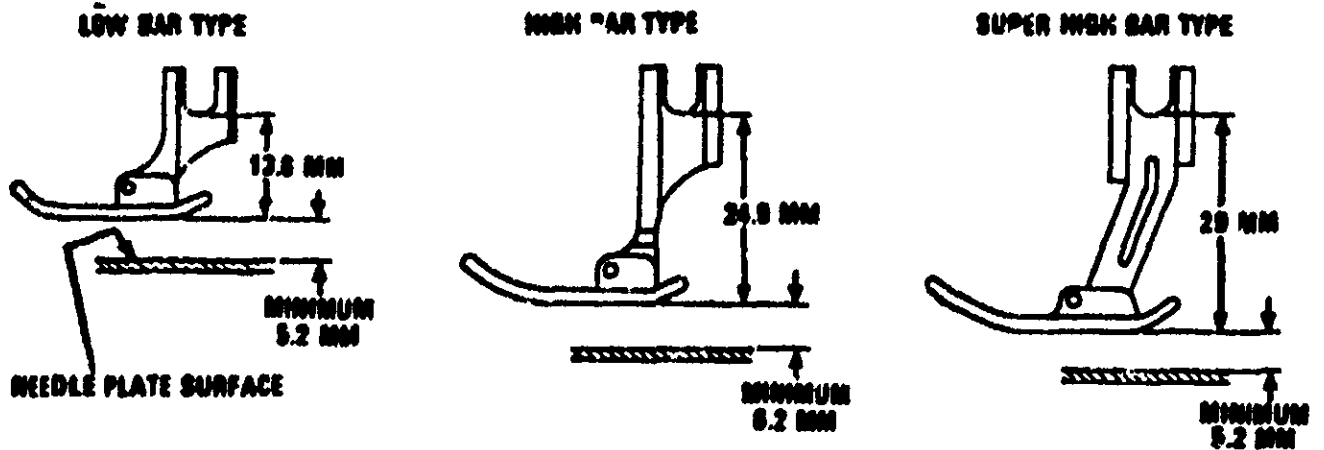

FRONT FACING SHUTTLE

SIDE FACING SHUTTLE

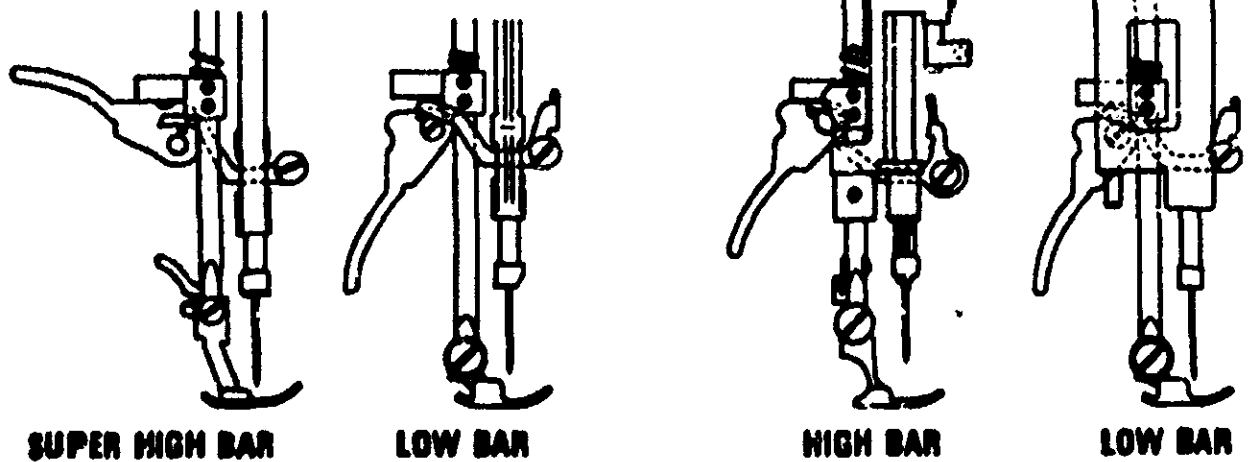

Drop feed dog. Press down pressure regulator to the minimum pressure. Lower pressure foot lever. Loosen thumb screw and be sure presser foot is seated properly. Tighten thumb screw.

If adjustment is necessary, raise presser foot lever and loosen screws on presser bar holder. Adjust the height of presser foot from needle plate as specified. Confirm the height of presser foot by a complete turn of the handwheel. Tighten the screws securely after adjustment.

FIGURE A-1

DISTRIBUTION OF NEEDLE SWING

CHECK NEEDLE POSITION AT STRAIGHT STITCHING BEFORE CHECKING DISTRIBUTION OF NEEDLE SWING MENTIONED BELOW.

SET THE SPECIAL STITCH SELECTOR DIAL AT ZIGZAG POSITION AND STITCH WIDTH CONTROL AT 4. TURNING THE HAND WHEEL, CHECK AND SEE IF THE NEEDLE GOES THROUGH THE NEEDLE SLOT AT POINTS EQUAL DISTANCE FROM EACH END OF THE NEEDLE SLOT.

IF ADJUSTMENT IS NEEDED, LOOSEN SCREW B AND ADJUST SCREW A TO GET CORRECT NEEDLE SWING. AFTER ADJUSTMENT, TIGHTEN SCREW B SECURELY.

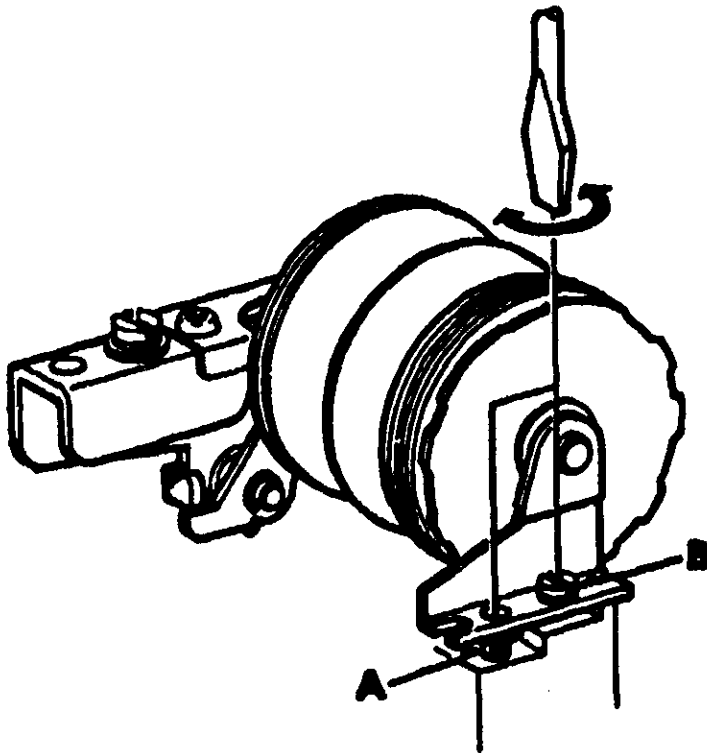

FIGURE C-25

NEEDLE POSITION

Set stitch width control at 0. Prepare the needle plate for straight stitching by reversing or sliding the center plate (See Figures 1 & 2) or place the needle plate insert for straight stitch into the needle plate (See Figure 3). Turning handwheel, check and see if the needle goes through the needle hole at its center. If not, loosen nut (1) and adjust needle position by slightly turning the eccentric roller pin (2). Tighten the nut securely after adjustment.

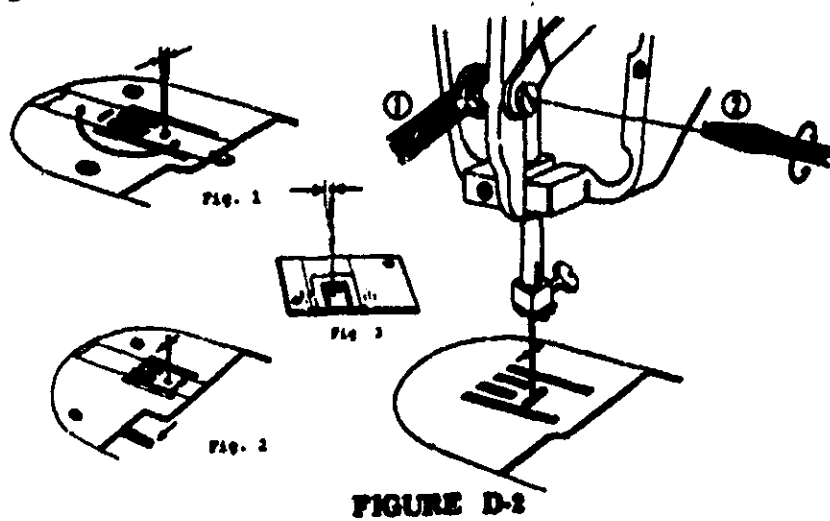

FIGURE D-2

FEED DOG HEIGHT

FOR FRONT FACING SHUTTLE MODELS, PLACE GAUGE AT POSITION AS ILLUSTRATED WITH THE NO-GO-SIDE OF THE GAUGE FACING THE NEEDLE PLATE. LOWER PRESSER FOOT. WHILE TURNING THE HANDWHEEL SLOWLY BY HAND, THE GAUGE SHOULD BE MOVED BY THE FEED DOG TEETH. IF NOT, FEED DOG TEETH ARE TOO LOW. THEN PLACE THE GAUGE UP-SIDE-DOWN WITH THE GO-SIDE FACING THE NEEDLE PLATE. REPEAT THE SAME PROCEDURE. THE GAUGE SHOULD NOT BE MOVED. IF THE GAUGE IS MOVED, THE FEED DOG TEETH ARE TOO HIGH.

IN CHART FORM IT LOOKS LIKE THIS:

Feed Dog Height Gauge	Go-Side (Facing Needle Plate)	No-Go-Side (Facing Needle Plate)
Correct	Not Moving	Moving
Low	Not Moving	Moving
High	Moving	Moving

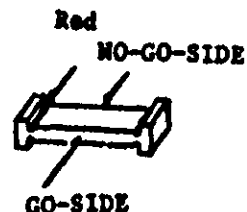

IF ADJUSTMENT IS NECESSARY, LOOSEN SCREW (2) ON FEED ROLLER AND BRACKET ASSEMBLY AND ADJUST THE FEED DOG HEIGHT AS SPECIFIED. TIGHTEN THE SCREW SECURELY AFTER ADJUSTMENT.

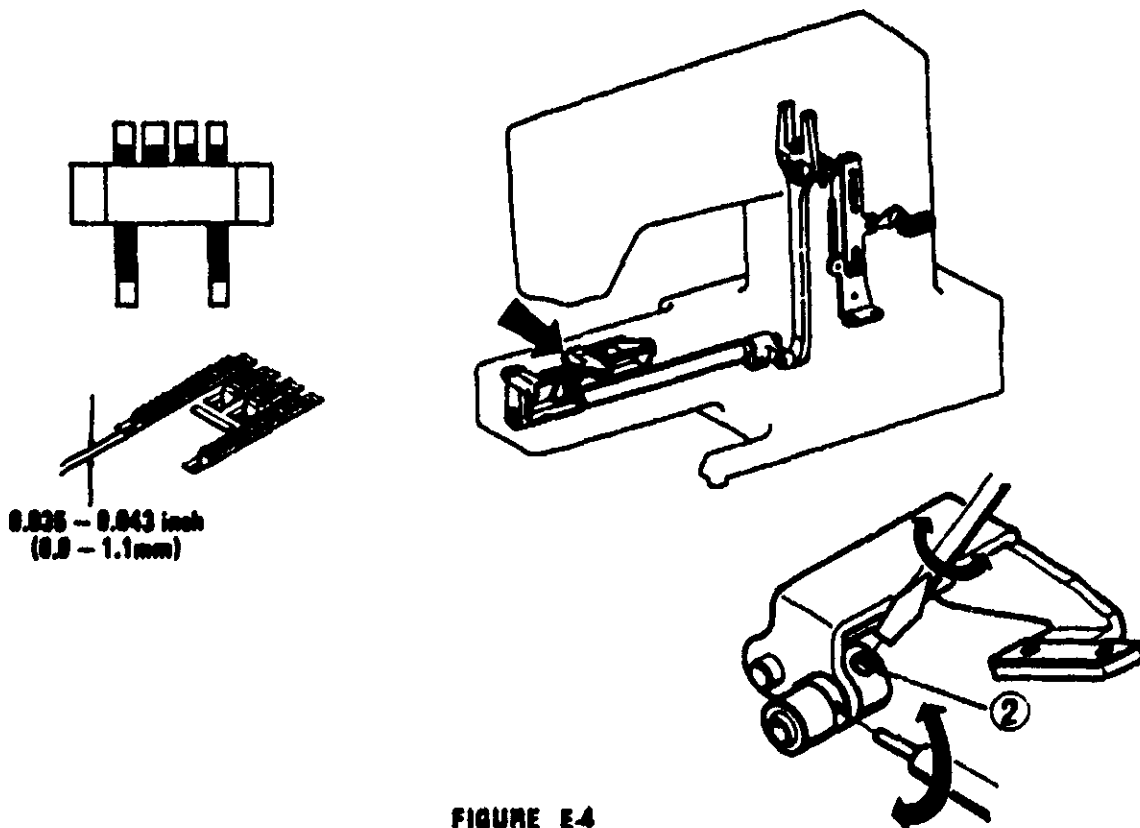

FIGURE E-4

ZERO-FEEDING

CHECKING

- 1) SET STITCH PATTERN SELECTOR AT STRAIGHT STITCHING.
- 2) SET STITCH LENGTH CONTROL AT "0".
- 3) PLACE PAPER ON THE NEEDLE PLATE.
- 4) CHECK AND SEE IF THE FEED DOG MOVES WHEN TURNING THE REVERSE STITCH CONTROL CLOCKWISE AND WHEN RELEASING THE CONTROL. AT "0" POSITION THE FEED DOG SHOULD NOT MOVE IN EITHER CASE. IF IT DOES, ADJUSTMENT IS NEEDED.

REMOVE IDLER PULLEY SET. LOOSEN SCREWS (A) AND (B) SLIGHTLY AND INSERT THE ECCENTRIC TOOL INTO HOLE (C) ON FEED REGULATOR ASSEMBLY. TURN THE ECCENTRIC TOOL EITHER WAY TO ELIMINATE MOVEMENT OF THE FEED DOG AND TIGHTEN SCREW (B). AFTER RIGHTENING SCREW (B), TIGHTEN SCREW (A) SECURELY.

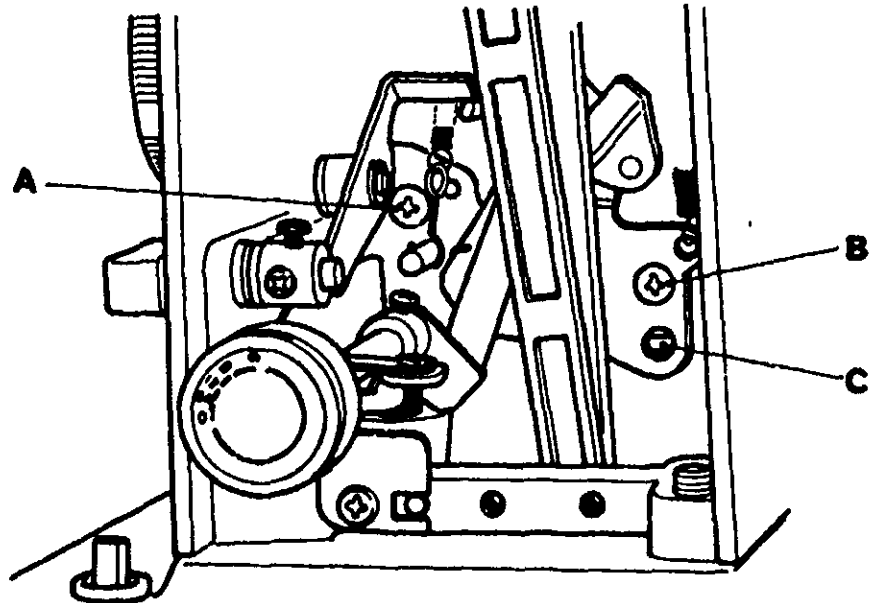

FIGURE F-20

NEEDLE TIMING TO SHUTTLE NEEDLE BAR HEIGHT

THE RADIAL TIMING GAUGES AND TEST PINS, AS ILLUSTRATED BELOW, ARE AVAILABLE THROUGH DEPARTMENT 206, CHICAGO ONLY. THE KIT IS IDENTIFIED AS NO 69659. EACH GAUGE AND TEST PIN CAN ALSO BE ORDERED INDIVIDUALLY.

THIS KIT IS USED FOR SOURCE 148 AND 158 VERTICAL BOBBIN SEWING MACHINES.

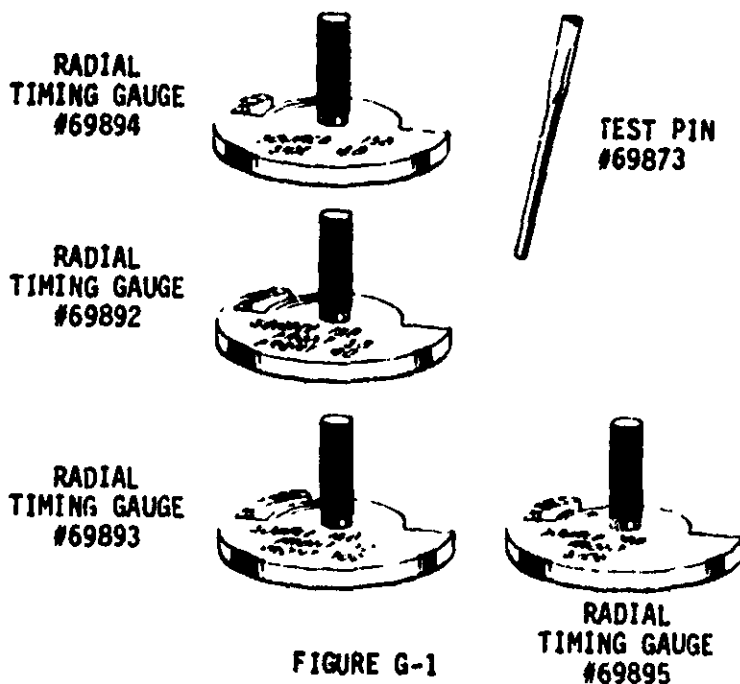

FIGURE G-1

RADIAL
TIMING GAUGE
#69895

NEEDLE TIMING TO SHUTTLE

Do not attempt adjustments other than those specified in this manual. If, by following the prescribed procedures, it is determined that a machine is out of radial time, handle per Bulletin S-820.

Radial Timing Gauge Instructions

1. Remove needle and replace it with test pin which has a blunt tip.
 2. Insert correct radial timing gauge into shuttle driver.
Use gauge marked:
Source 158 FRONT 5.8 FRONT 4.0
Use FRONT 5.8 marking.
 3. Set stitch control at "0" or "S" (depending on model involved).
On machines with 7.0 zigzag bite which have a left needle straight stitch position, center the needle by means of the stitch width control. Use center strip between rear feeddogs as a guide for centering the needle.
 4. Set needle position control at center for models which have this control.
 5. Rotate handwheel slowly by hand. (See Figure G-3a.) The test pin should come between the correct two vertical lines at the end of the counterclockwise rotation of the gauge.
 6. To check needle bar height, continue to rotate handwheel slowly by hand. (See Figure G-3b.) At the lowest position of the needle bar, the end of the test pin should come between two horizontal lines on the gauge.
- If necessary, adjust needle bar height. Loosen screw on needle bar holder and adjust height on the test pin.

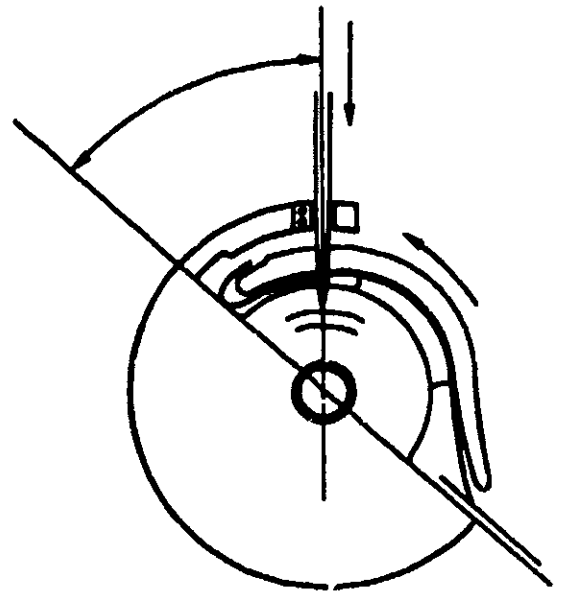

DIMENSION A

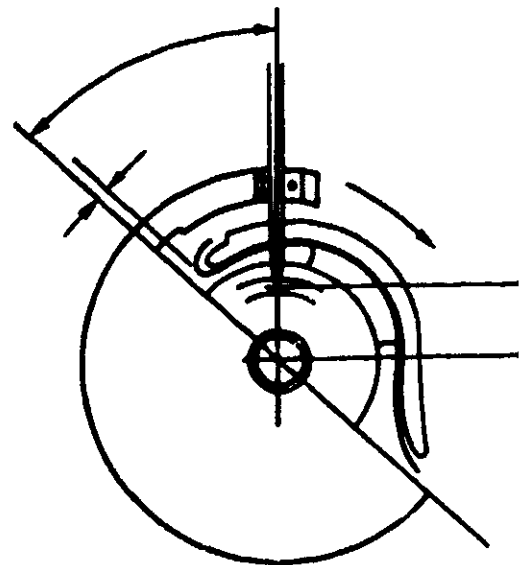

DIMENSION B

FIGURE G-3

ZIGZAG SYNCHRONIZATION

SET STITCH WIDTH CONTROL AT MAXIMUM ZIGZAG POSITION. TURN HANDWHEEL, OBSERVING THAT THE NEEDLE GOES STRAIGHT UP WITH NO SIDE MOVEMENT TO A POINT 2-3 MM ABOVE THE NEEDLE PLATE. AT THIS POINT THE NEEDLE SHOULD BEGIN TO SWING OVER TO THE OTHER SIDE. VERIFY THAT THE NEEDLE GOES STRAIGHT DOWN AT THE OTHER SIDE.

IF ADJUSTMENT IS NECESSARY, LOOSEN SCREW (A) SLIGHTLY AND TURN THE WORM GEAR IN EITHER DIRECTION.

AFTER ADJUSTMENT TIGHTEN SCREW (A) SECURELY.

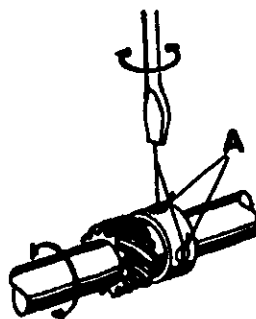
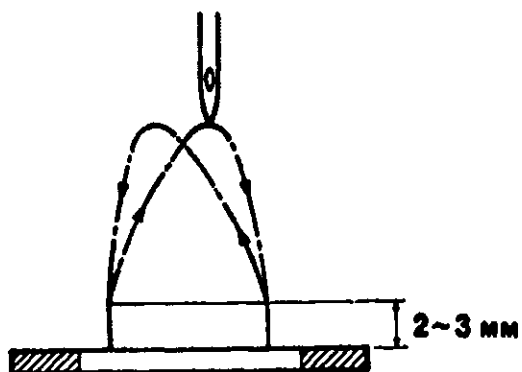

FIGURE H-5

AUTOMATIC REVERSE STITCHING STRETCH STITCH

SET SPECIAL STITCH SELECTOR DIAL OR KNOB AT ZIGZAG STRETCH STITCHING AND STITCH WIDTH CONTROL AT "4" AND STITCH LENGTH CONTROL AT "6". IF MACHINE HAS MODIFIER FOR STRETCH STITCH, SET IT AT THE CENTER BETWEEN "L" AND "S" POSITION.

NOTE: IN THE CASE OF SINGLE DIAL MACHINE, STITCH WIDTH AND STITCH LENGTH ARE AUTOMATICALLY SET WHEN TURNING DIAL TO ZIGZAG STRETCH STITCHING.

CHECK TO SEE IF FORWARD STITCHES ARE EQUAL IN LENGTH WITH REVERSE STITCHES BY ZIGZAG STITCHING ON PAPER. IF ADJUSTMENT IS NECESSARY, LOOSEN SCREW (B) SLIGHTLY AND TURN SCREW (A) EITHER WAY UNTIL BOTH STITCHES ARE EQUAL. AFTER ADJUSTMENT, TIGHTEN SCREW (B) SECURELY.

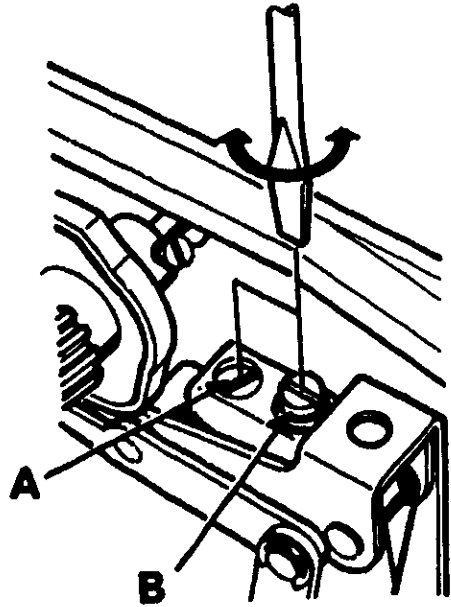

FIGURE J-36

AUTOMATIC REVERSE STITCHING BUTTONHOLE

**CHECK ZERO FEEDING BEFORE CHECKING AUTOMATIC FORWARD AND REVERSE STITCH FOR
BUTTONHOLE.**

**SET STITCH LENGTH CONTROL AT GREEN ZONE. ATTACH BUTTONHOLE SHOE. CHECK
AND SEE IF THE LENGTH OF REVERSE STITCHES ARE EQUAL IN LENGTH WITH FORWARD
STITCHES. IF NOT, TURN SCREW (A) IN EITHER DIRECTION UNTIL BOTH STITCHES
ARE EQUAL IN LENGTH.**

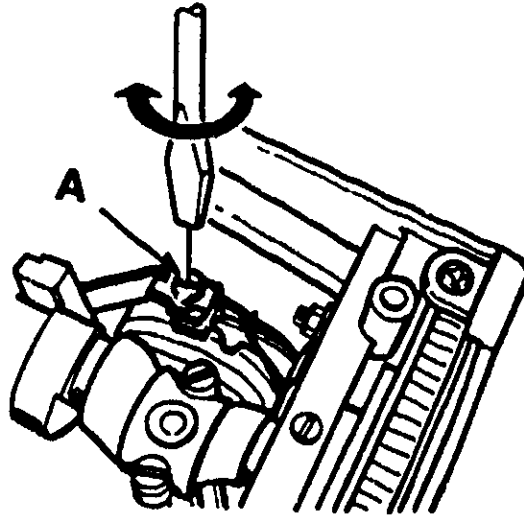

FIGURE J-40

STITCH WIDTH

SET STITCH SELECTOR AT THE WIDEST ZIGZAG STITCH. CHECK TO SEE IF THE ZIGZAG BITE IS AS SPECIFIED FOR THIS MODEL. IF NOT, LOOSEN SCREW (A) AND INSERT THE ECCENTRIC TOOL INTO HOLE (B). TURN THE ECCENTRIC TOOL IN EITHER DIRECTION UNTIL YOU GET THE SPECIFIED WIDTH.

TIGHTEN SCREW (A) SECURELY AFTER ADJUSTMENT.

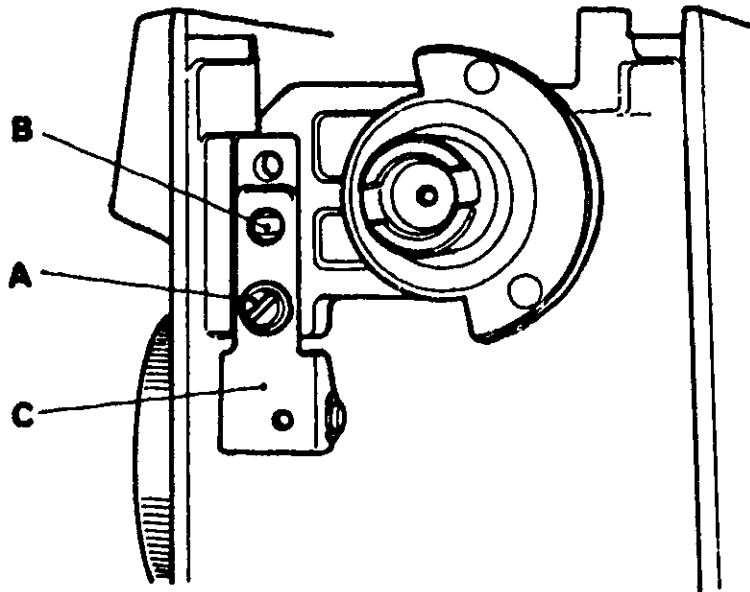

FIGURE L-6

Automatic Mechanism Cam and Cam Follower Mechanism

SET SPECIAL STITCH SELECTOR DIAL OR KNOB AT ZIGZAG POSITION. CHECK TO SEE IF THE CAM FOLLOWER (B) ALIGNS PROPERLY WITH ZIGZAG CAM (C, THIRD DISC FROM BACK). IF ADJUSTMENT IS NECESSARY, LOOSEN SCREWS (A) TO ADJUST STITCH CHANGE PLATE ASSEMBLY. AFTER ADJUSTMENT TIGHTEN SCREWS (A) SECURELY. RECHECK AND SEE IF FOLLOWER ALIGNS PROPERLY WITH EACH CAM.

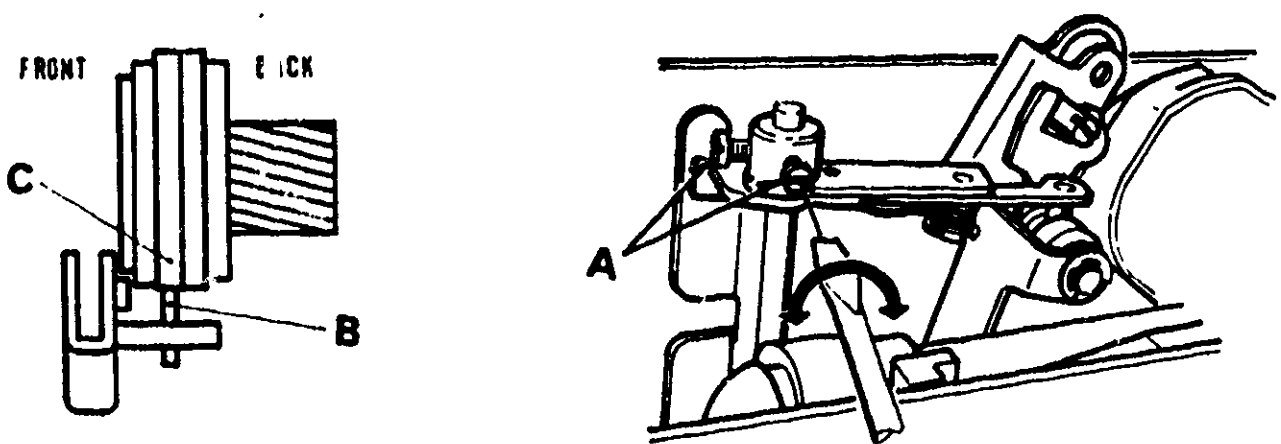

FIGURE M-11