



BOWFLEX[™]
BXT8J / BXT8Ji

ASSEMBLY / OWNER'S MANUAL



Welcome to the Bowflex™ BXT8J / BXT8Ji machine!

You're about to experience an incredible workout that can help you lose weight and reshape your entire body so you'll look and feel better than ever before. We thank you for trusting in the Bowflex brand.

Use this Manual as a guide to getting started on your Bowflex™ workouts and for tips to keep your machine well maintained.

Yours in Health,
The Bowflex Family

Table of Contents

Important Safety Instructions.....	3	Quick Start Program.....	42
Safety Warning Labels / Serial Number.....	5	User Profiles.....	42
Grounding / Earthing Instructions.....	6	Profile Programs.....	44
Emergency Stop Procedure.....	7	Compare Pacer Displays.....	47
Specifications.....	8	Fitness Score Display.....	48
Before Assembly.....	8	Pausing or Stopping.....	48
Parts.....	9	Results / Cool Down Mode.....	49
Hardware.....	10	GOAL TRACK Statistics.....	50
Tools.....	10	Console Setup Mode.....	51
Assembly.....	10	Maintenance.....	52
Storage and Moving the Machine.....	22	Cleaning.....	52
Unfolding the Machine.....	24	Adjusting the Walking Belt.....	52
Leveling the Machine.....	25	Aligning the Walking Belt.....	53
Features.....	26	Lubricating the Walking Belt.....	53
Console Features.....	27	Heart Rate Chest Strap Battery Replacement.....	54
Remote Heart Rate Monitor.....	31	Maintenance Parts.....	55
Fitness Basics.....	33	Troubleshooting.....	57
Operations.....	40	Body Weight Loss Guide.....	59
Getting Started.....	40	Warranty (US/Canada only).....	67
Power Up / Idle Mode.....	41		
Initial Setup.....	41		

To validate warranty support, keep the original proof of purchase and record the following information:

Serial Number _____

Date of Purchase _____

If purchased in US/Canada: To register your product warranty, go to: www.bowflex.com/register or call 1 (800) 605-3369.

If purchased outside US/Canada: To register your product warranty, contact your local distributor.

For warranty and service of products purchased outside US/Canada, please contact your local distributor. Nautilus, Inc. will cover the frame and drive motor. Contact your local distributor for key details. To find your local international distributor, go to: www.nautilusinternational.com.

Nautilus, Inc., 5415 Centerpoint Parkway, Groveport, OH 43125 USA, www.NautilusInc.com - Customer Service: North America (800) 605-3369, csnls@nautilus.com | Nautilus (Shanghai) Fitness Equipments Co, Ltd, Room 1701 &1702, 1018 Changning Road, Changning District, Shanghai, China 200042, www.nautilus.cn - 86 21 6115 9668 | outside U.S. www.nautilusinternational.com | Printed in China | © 2022 Nautilus, Inc. | Bowflex, the B logo, JRNY, Nautilus, and Schwinn are trademarks owned or licensed by Nautilus, Inc., registered or otherwise protected by common law in the U.S. and other countries. Polar®, OwnCode®, Android™, Google Play™, and Nut Thins® are trademarks of their respective owners. Apple and the Apple logo are trademarks of Apple Inc., registered in the U.S. and other countries. App Store is a service mark of Apple Inc. The Bluetooth® word mark and logos are registered trademarks owned by Bluetooth SIG, Inc., and any use of such marks by Nautilus, Inc. is under license. Other trademarks are the property of their respective owners.

ORIGINAL MANUAL - ENGLISH VERSION ONLY



IMPORTANT SAFETY INSTRUCTIONS

When using an electrical appliance, basic precautions should always be followed, including the following:



This icon means a potentially hazardous situation which, if not avoided, could result in death or serious injury.

Obey the following warnings:



Read and understand all Warnings on this machine.

Carefully read and understand the Assembly/Owner's Manual.

⚠ DANGER

Carefully read and understand the Assembly instructions. Read and understand the complete Manual. Keep the Manual for future reference.

⚠ DANGER

To reduce the risk of electrical shock or unsupervised usage of the equipment, always unplug this machine from the electrical outlet immediately after using and before cleaning.

⚠ WARNING

To decrease the risk of burns, electric shock, or injury to persons, read and understand the complete Assembly/Owner's Manual. Failure to follow these guidelines can cause a serious or possibly fatal electrical shock or other serious injury.

- Keep bystanders and children away from the product you are assembling at all times.
- Do not connect power supply to the machine until instructed to do so.
- The machine should never be left unattended when plugged in. Unplug from outlet when not in use, and before putting on or taking off parts.
- Before each use, examine the machine for damage to power cord, loose parts or signs of wear. Do not use if found in this condition. If purchased in US/Canada, contact Customer Service for repair information. If purchased outside US/Canada, contact your local distributor for repair information.
- Not intended for use by persons with medical conditions where those conditions may impact the safe operation of the treadmill or pose a risk of injury to the user.
- Do not drop or put objects into any opening of the machine.
- Never operate this treadmill with the air openings blocked. Keep the air openings free of lint, hair and the like.
- Do not assemble this machine outdoors or in a wet or moist location.
- Make sure assembly is done in an appropriate work space away from foot traffic and exposure to bystanders.
- Some components of the machine can be heavy or awkward. Use a second person when doing the assembly steps involving these parts. Do not do steps that involve heavy lifting or awkward movements on your own.
- Set up this machine on a solid, level, horizontal surface.
- Do not try to change the design or functionality of this machine. This could compromise the safety of this machine and will void the warranty.
- If replacement parts are necessary, use only genuine Nautilus replacement parts and hardware. Failure to use genuine replacement parts can cause a risk to users, keep the machine from operating correctly and void the warranty.
- Do not use until the machine has been fully assembled and inspected for correct performance in accordance with the Manual.
- Use this machine only for its intended use as described in this manual. Do not use attachments not recommended by the manufacturer.
- Do all assembly steps in the sequence given. Incorrect assembly can lead to injury or incorrect function.
- Connect this machine to a properly grounded outlet only (see Grounding or Earthing Instructions).
- Keep the power cord away from heat sources and hot surfaces.
- Do not operate where aerosol products are being used.
- To disconnect, turn all controls to the off position, then remove plug from outlet.

• **SAVE THESE INSTRUCTIONS.**

Before using this equipment, obey the following warnings:



Read and understand the complete Manual. Keep the Manual for future reference.

Read and understand all warnings on this machine. If at any time the Warning labels become loose, unreadable or dislodged, replace the labels. If purchased in US/Canada, contact Customer Service for replacement labels. If purchased outside US/Canada, contact your local distributor for them.

⚠ DANGER

To reduce the risk of electrical shock or unsupervised usage of the equipment, always unplug the power cord from the wall outlet and/or the machine and wait 5 minutes before cleaning, maintaining or repairing the machine. Place the power cord in a secure location.

- Children must not be let on or near to this machine. Moving parts and other features of the machine can be dangerous to children.
- Not intended for use by anyone under 14 years of age. Individuals between 14 and 17 years of age must be supervised when using this machine.
- Consult a physician before you start an exercise program. Stop exercising if you feel pain or tightness in your chest, become short of breath, or feel faint. Contact your doctor before you use the machine again. Use the values calculated or measured by the machine's computer for reference purposes only.
- Before each use, examine this machine for damage to power cord, power receptacle, loose parts or signs of wear. Do not use if found in this condition. If purchased in US/Canada, contact Customer Service for repair information. If purchased outside US/Canada, contact your local distributor for repair information.
- Maximum user weight limit: 136 kg (300 lbs.). Do not use if you are over this weight.
- This machine intended for Home/Consumer or Studio/Institutional use. Studio/Institutional use is defined as settings where usage is less than 3 hours per day in non-dues-paying facilities --for example, condominiums, hotels and corporate gyms.
- Do not wear loose clothing or jewelry. This machine contains moving parts. Do not put fingers or other objects into moving parts of the exercise equipment.
- Always wear rubber soled athletic shoes when you use this machine. Do not use the machine with bare feet or only wearing socks.
- Set up and operate this machine on a solid, level, horizontal surface.
- Use caution when you step on and off the machine. Use the supplied foot support platforms for stability before walking on the moving belt.
- To prevent injury, stand on the foot support platforms before you start the machine or end a workout. Do not dismount the machine by standing on the moving Walking Belts and exiting off the rear of the machine.
- Disconnect all power before servicing this machine.
- Do not operate this machine outdoors or in moist or wet locations.
- Keep at least 0.5 m (19.7 in) on each side of the machine and 2 m (79 in) behind the machine clear. This is the recommended safe distance for access and passage around and emergency dismounts from the machine. Keep third parties out of this space when machine is in use.
- Do not over exert yourself during exercise. Operate the machine in the manner described in this manual.
- Perform all regular and periodic maintenance procedures recommended in the manual.
- Read, understand, and test the Emergency Stop Procedure before use
- Keep the walking belt clean and dry.
- Do not drop or put objects into any opening of the machine.
- Do not stand on machine motor cover or front trim cover.
- Keep power cord away from heat source and hot surfaces.
- This machine must be connected to an appropriate, dedicated electrical circuit. Nothing else must be connected to the circuit.
- Always connect the power cord to a circuit capable of handling 15 amperes for 110V AC or 10 amperes for 220-240V AC with no other loads applied.
- Connect this machine to a correctly grounded outlet; consult a licensed electrician for assistance.
- Do not operate where aerosol (spray) products are being used or where oxygen is being administered.
- Do not let liquids touch the electronic controller. If it does, the controller must be inspected and tested for safety by an approved technician before it can be used again.
- The electrical wiring for the residence in which the machine will be used must obey the applicable local and provincial requirements.
- Exercise on this machine requires coordination and balance. Be sure to anticipate that changes in belt speed and incline angle of deck can occur during workouts, and be attentive in order to avoid loss of balance and possible injury.
- A machine should never be left unattended when plugged in. Unplug from outlet when not in use, and before putting on or taking off parts.
- Use this machine only for its intended use as described in this manual. Do not use attachments not recommended by the manufacturer.

- This appliance is not intended for use by persons with reduced physical, sensory or mental capabilities, or lack of knowledge, unless they have been given supervision or instruction concerning use of the appliance by a person responsible for their safety. Keep children under the age of 14 away from this machine.
- When the machine is put in a Studio/Institutional environment, it can only be used in areas where access and control of the machine are managed and supervised by approved staff. The degree of supervision and oversight depends among other things on the specific setting in which the machine is placed, security of that environment, and familiarity of the users with the equipment. Because others may have used the machine previously, make sure that all parts and hardware are fully tightened and secured.
- Children should be supervised to ensure that they do not play with the appliance.
- **SAVE THESE INSTRUCTIONS.**

Safety Warning Labels and Serial Number

CAUTION!

Risk of Injury to Persons - To Avoid injury, use extreme caution when stepping onto or off of a moving belt. Read instruction manual before using.



WARNING!

- Injury or death is possible if caution is not used while using this machine.
- Keep children and pets away.
- Read and follow all warnings on this machine.
- Refer to the Owner's Manual for additional warnings and safety information.
- The heart rate displayed is an approximation and should be used for reference only.
- Not intended for use by anyone under 14 years of age.
- The maximum user weight for this machine is 300 lbs (136 kg).
- This machine is for home use only.
- Consult a physician prior to using any exercise equipment.

(The label is only available on the BXT8J in English and French Canadian.)

WARNING!

Keep young children away from this machine at all times. Contact with the moving surface may result in severe friction burns.
(This label is only available on the BXT8Ji machine in English.)

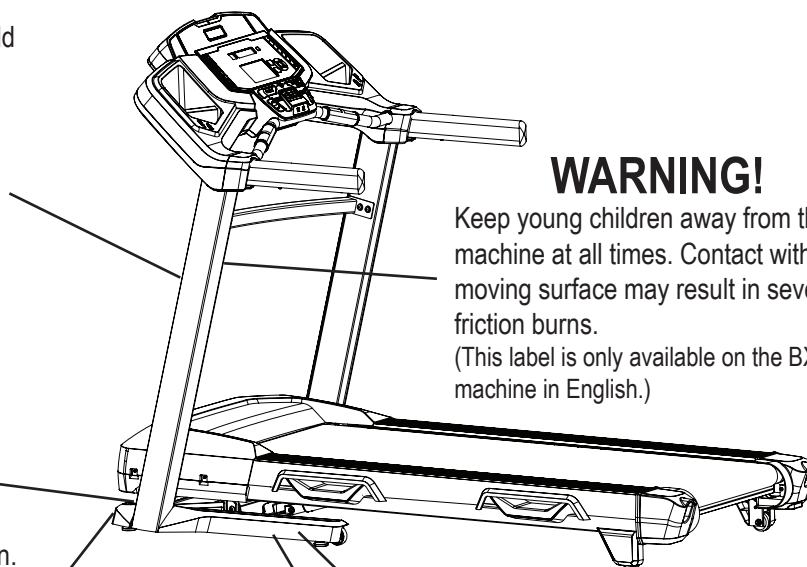

WARNING!

HAZARDOUS VOLTAGE.

- Contact may cause electrical shock or burn.
- Turn off and lock out power before servicing.



WARNING!

- Moving parts can crush and cut.
- Keep guards in place.
- Lock out power before servicing.

(These labels are only available in English and French Canadian.)

Serial Number

Product Specification

Grounding Instructions (for a 120V AC system)

This product must be grounded. If it should malfunction or break down, grounding provides a path of least resistance for electric current to reduce the risk of electric shock. This product is equipped with a cord having an equipment-grounding conductor and a grounding plug. The plug must be plugged into an appropriate outlet that is properly installed and grounded in accordance with all local codes and ordinances.

⚠ DANGER

Improper connection of the equipment-grounding conductor can result in a risk of electric shock. Check with a qualified electrician or service person if you are in doubt as to whether the product is properly grounded. Do not modify the plug provided with the product – if it will not fit the outlet, have a proper outlet installed by a qualified electrician.

If you connect the machine to an outlet with GFI (ground fault interrupt) or AFI (arc fault interrupt), machine operation can cause the circuit to trip.

⚠ This machine is for use on a nominal 120-V circuit, and has a grounding plug that looks like the plug illustrated below. A temporary adapter that looks like the adapter illustrated may be used to connect this plug to a 2-pole receptacle as shown if a properly grounded outlet is not available.

The temporary adapter should be used only until a properly grounded outlet can be installed by a qualified electrician. The tab for the grounding screw must be connected to a permanent ground such as a properly grounded outlet box cover. Whenever the adapter is used, it must be held in place by a metal screw.

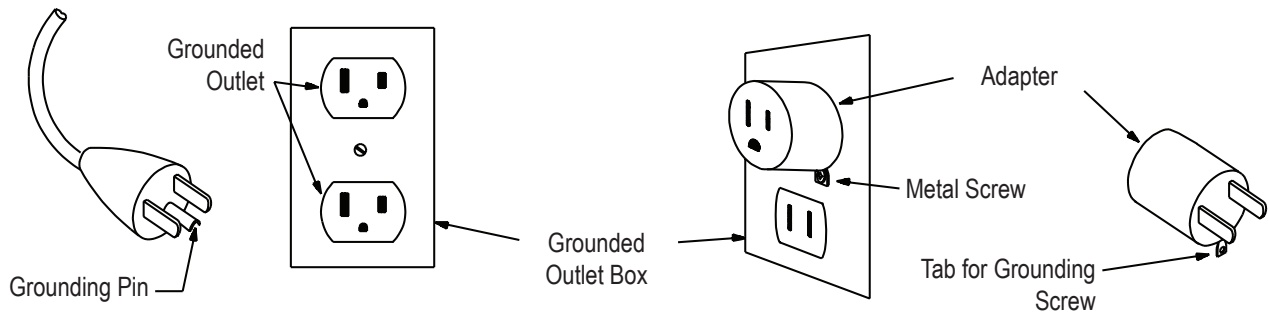

Earthing Instructions (for a 220-240V AC system)

This product must be electrically earthed. If a malfunction occurs, correct earthing decreases the risk of electric shock. The power cord is equipped with an equipment-earthing conductor, and must be connected to an outlet that is properly installed and earthed.

⚠ DANGER

The electrical wiring must comply with all applicable local and provincial standards and requirements. Incorrect connection of the equipment-earthing conductor can result in a risk of electric shock. Consult a licensed electrician if you are not sure that the machine is correctly earthed. Do not change the plug on the machine – if it does not fit the outlet, have a correct outlet installed by a licensed electrician.

If you connect the machine to an outlet with RCBO (Residual-Current circuit Breaker with Overload protection), machine operation can cause the circuit to trip. A Surge Protector Device is recommended to protect the machine.

⚠ If a Surge Protector Device (SPD) is used with this machine, be sure that it matches the power rating of this equipment (220-240V AC). Do not connect other appliances or devices to the surge protector in combination with this machine.

Make sure that the product is connected to an outlet having the same configuration as the plug. Use the appropriate adapter supplied with this product.

Emergency Stop Procedure

The Treadmill machine is equipped with a Safety Key that can prevent serious injury, as well as prevent children from playing with and/or being injured on the machine. If the Safety Key is not correctly inserted into the Safety Key Port, the belt will not operate.

 **Always attach the Safety Key Clip to your clothing during your workout.**

When you use the machine, only remove the Safety Key in an emergency. When the key is removed while the machine is in operation, it will stop quickly, which could cause the loss of balance and possible injury.

For safe storage of the machine, and to prevent unsupervised operation of the machine, always remove the Safety Key and disconnect the power cord from the wall outlet and the AC input. Place the power cord in a secure location.

The Console will display, “ Safety Key Disconnected. To do a workout, insert the Safety key. “, when there is a Safety Key fault. The Treadmill machine will not start a Workout, or will end and clear an active Workout, when the Safety Key is removed. Inspect the Safety Key and be sure it is connected to the Console correctly.

Specifications / Before Assembly

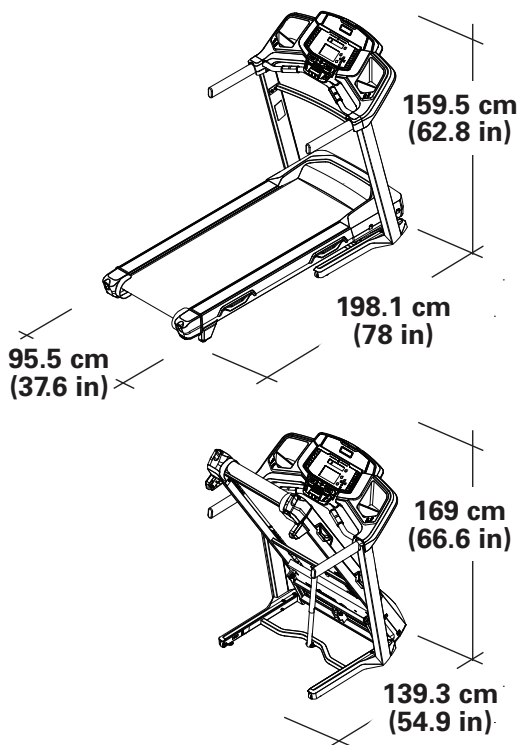

Power Requirements:	120V	220V
Operational Voltage:	110-127V AC, 60Hz	220V - 240V AC, 50/60Hz
Operating Current:	15 A	8 A
Heart Rate Chest Strap:	1 CR2032 battery	

Maximum User Weight:	136 kg. (300 lbs)
Total Surface Area (footprint) of equipment:	16,468 cm ²
Maximum Inclined Deck Height:	43.7 cm (17.2 in)
Assembled Weight:	approx. 115 kg (253.5 lbs)

Sound Emission: Less than 70 db average without load.
Noise emission under load is higher than without load.

This product complies with the European Radio Equipment Directive 2014/53/EU



DO NOT dispose of this product as refuse. This product is to be recycled. For proper disposal of this product, please follow the prescribed methods at an approved waste center.

Before Assembly

Select the area where you are going to set up and operate your machine. For safe operation, the location must be on a hard, level surface. Allow a workout area of a minimum 1.96 m x 4 m (77 in x 157 in). Be sure that the workout space you are utilizing has adequate height clearance, taking into consideration the height of the user and the maximum incline of the machine.

Basic Assembly Tips

Follow these basic points when you assemble your machine:

- Read and understand the "Important Safety Instructions" before assembly.
- Collect all the pieces necessary for each assembly step.
- Using the recommended wrenches, turn the bolts and nuts to the right (clockwise) to tighten, and the left (counterclockwise) to loosen, unless instructed otherwise.
- When attaching 2 pieces, lightly lift and look through the bolt holes to help insert the bolt through the holes.
- The assembly can require 2 people.

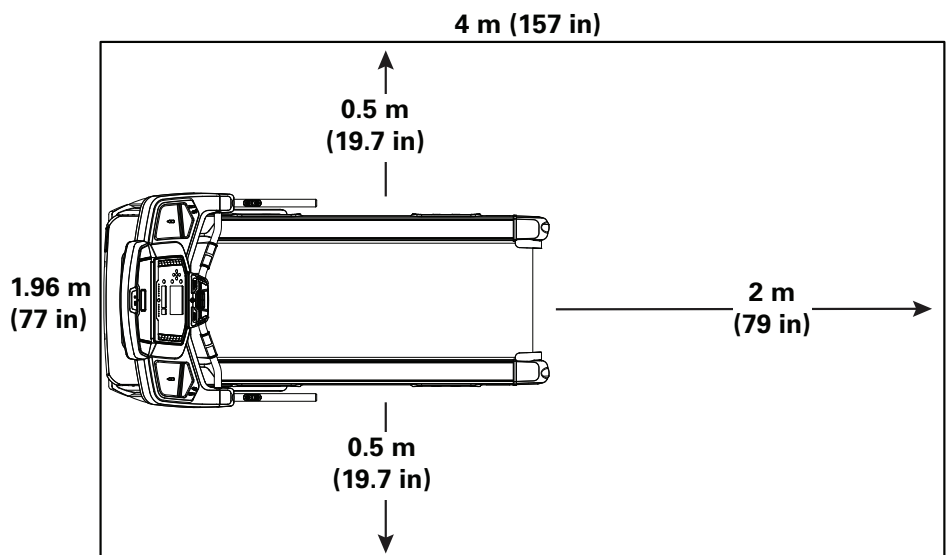

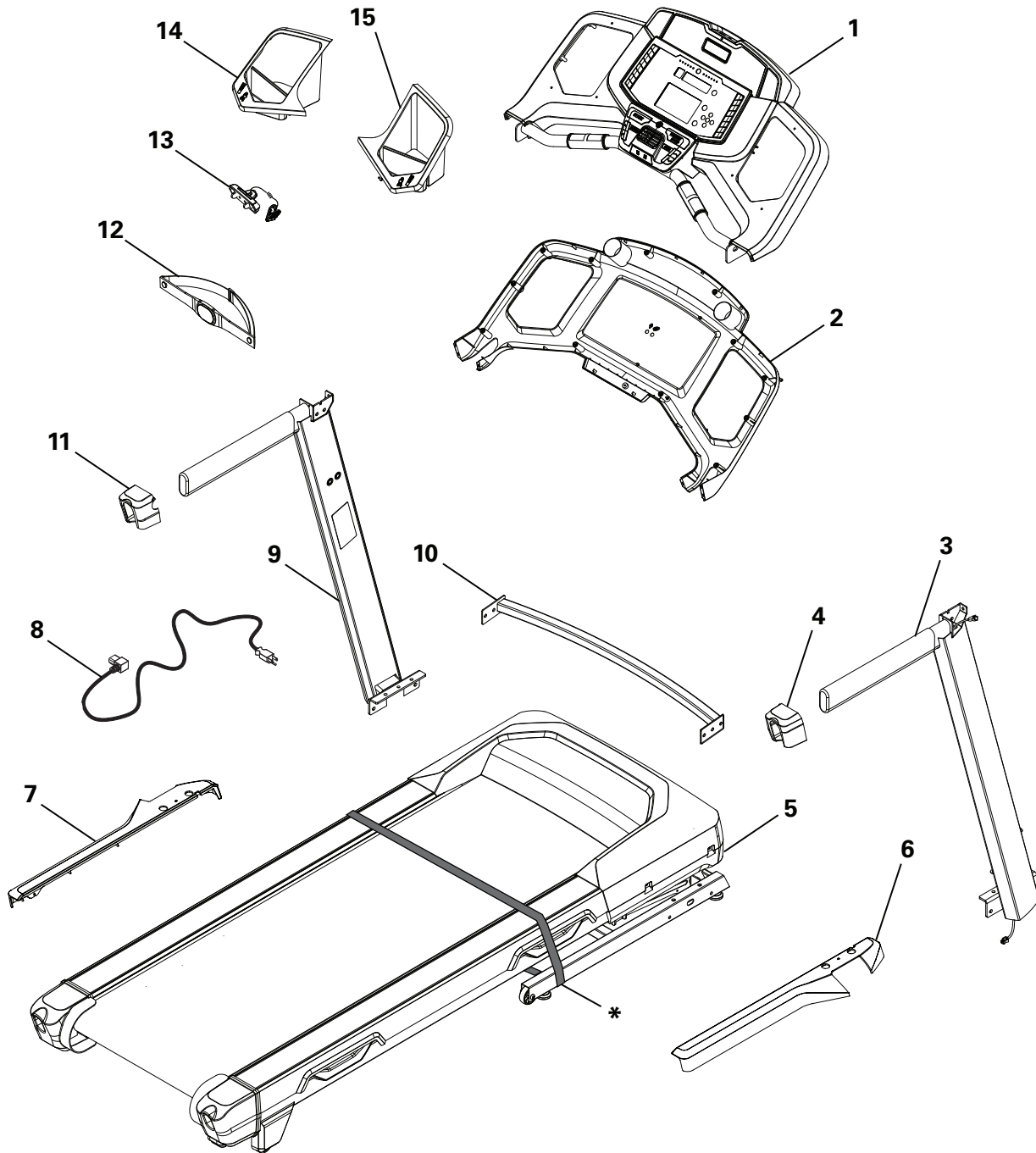

Item	Qty	Description	Item	Qty	Description
1	1	Console Assembly	9	1	Upright, Left
2	1	Console Backing	10	1	Crossbar
3	1	Upright, Right	11	1	Handlebar Shroud, Left
4	1	Handlebar Shroud, Right	12	1	Heart Rate Chest Strap
5	1	Base Assembly (*)	13	1	Safety Key
6	1	Base Shroud, Right	14	1	Cupholder, Left
7	1	Base Shroud, Left	15	1	Cupholder, Right
8	1	Power Cord	16	1	Media Cable (not shown)

⚠ WARNING

DO NOT CUT the Shipping Strap on the Base Assembly until it has been placed face up as shown in the appropriate work space (*).

Hardware / Tools



Item	Qty	Description	Item	Qty	Description
A	6	Self Tapping Screw, M3.9x9.5	B	13	Self Tapping Screw, M4.2x16

Note: Select pieces of Hardware have been provided as spares on the Hardware Card. Be aware that there may be remaining Hardware after the proper assembly of your machine.

Tools

Included



#2
6 mm

Not Included



(recommended)



Assembly

⚠ WARNING

DO NOT CUT the Shipping Strap on the Base Assembly until it has been placed face up as shown in the appropriate work space (*).

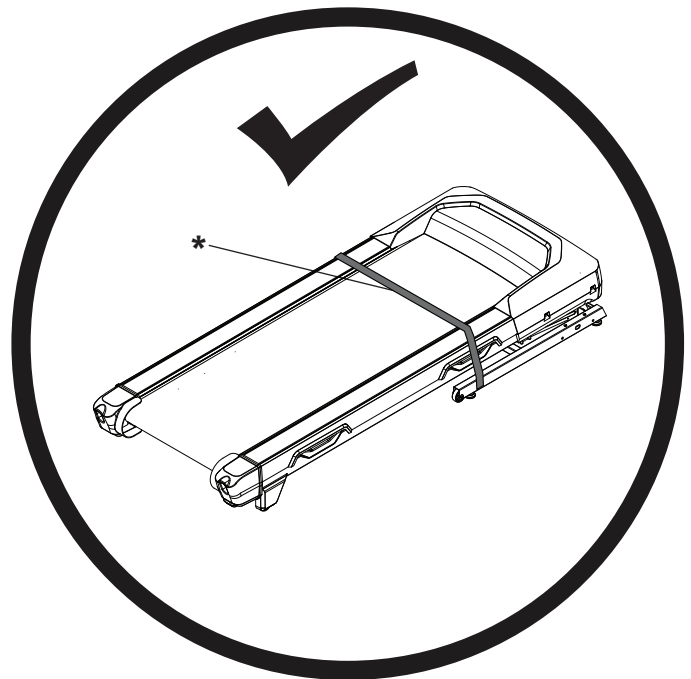
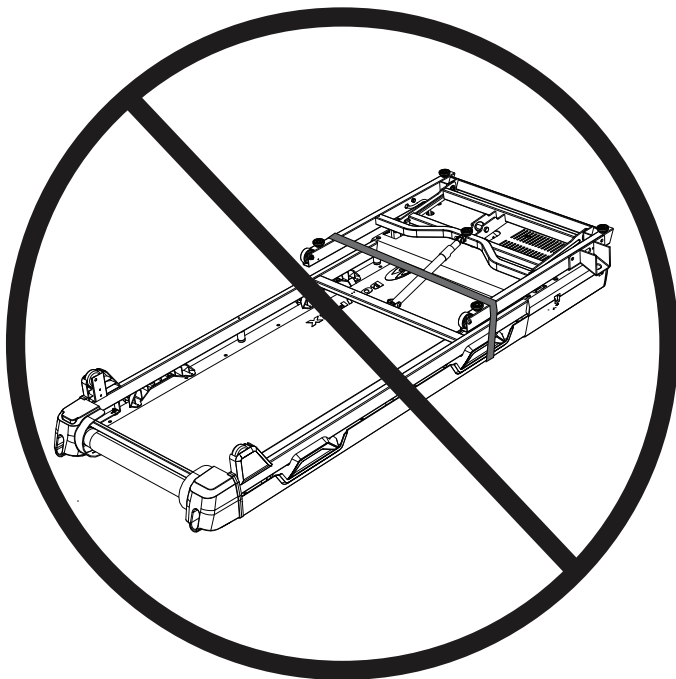

1. Fold the Walking Deck on the Base Assembly

Cut the Shipping Strap on the Base Assembly. Make sure that there is safe clearance around, on and above your treadmill. Make sure there is no object to spill or cause blockage from the fully folded position. Be sure there is adequate height clearance for the raised deck.

Using the support bar found below the rear of the walking belt, lift the walking deck fully upward and engage the hydraulic lift. Be sure that the hydraulic lift is correctly locked in place.

⚠ Use proper safety precautions and lifting techniques. Bend your knees and elbows, keep your back straight and pull up equally with both arms. Make sure that your own physical strength is capable of lifting the walking deck until it engages the locking mechanism. Use a second person if necessary.

Do not use the walking belt or rear roller to lift the treadmill. These parts do not lock in place and can abruptly move. Injury to you or damage to the machine can occur.

Make sure that the locking mechanism is engaged. Carefully pull back on the Walking Deck and make sure that it does not move. When you do this, keep clear of movement path in case the treadmill lock is not engaged.

⚠ Do not lean against the treadmill when it is folded. Do not put items on it that could cause it to become unstable or fall.

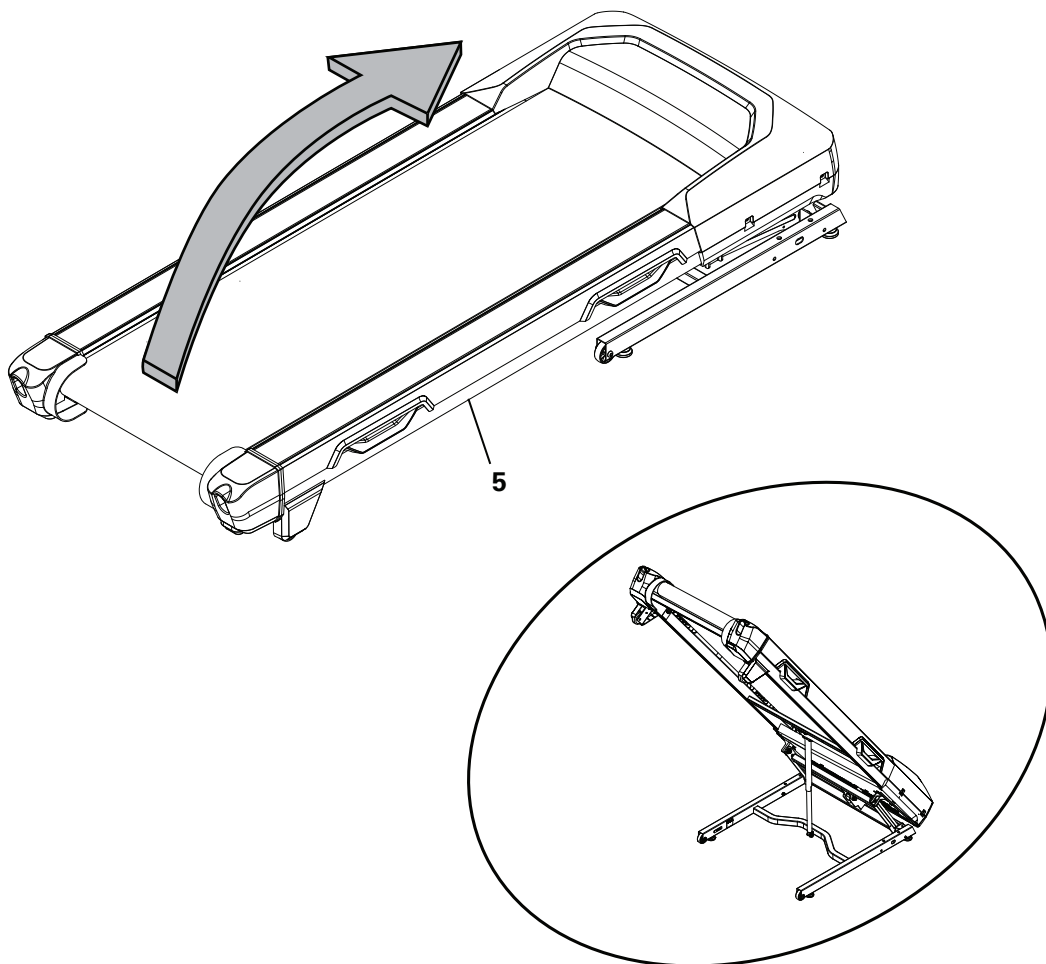

2. Connect the Cables from the Right Upright, and Attach the Uprights to the Frame

NOTICE: Do not pinch or cut the cables. Do not fully tighten Hardware until instructed. *Hardware is pre-installed, and not supplied in the Hardware Bag.

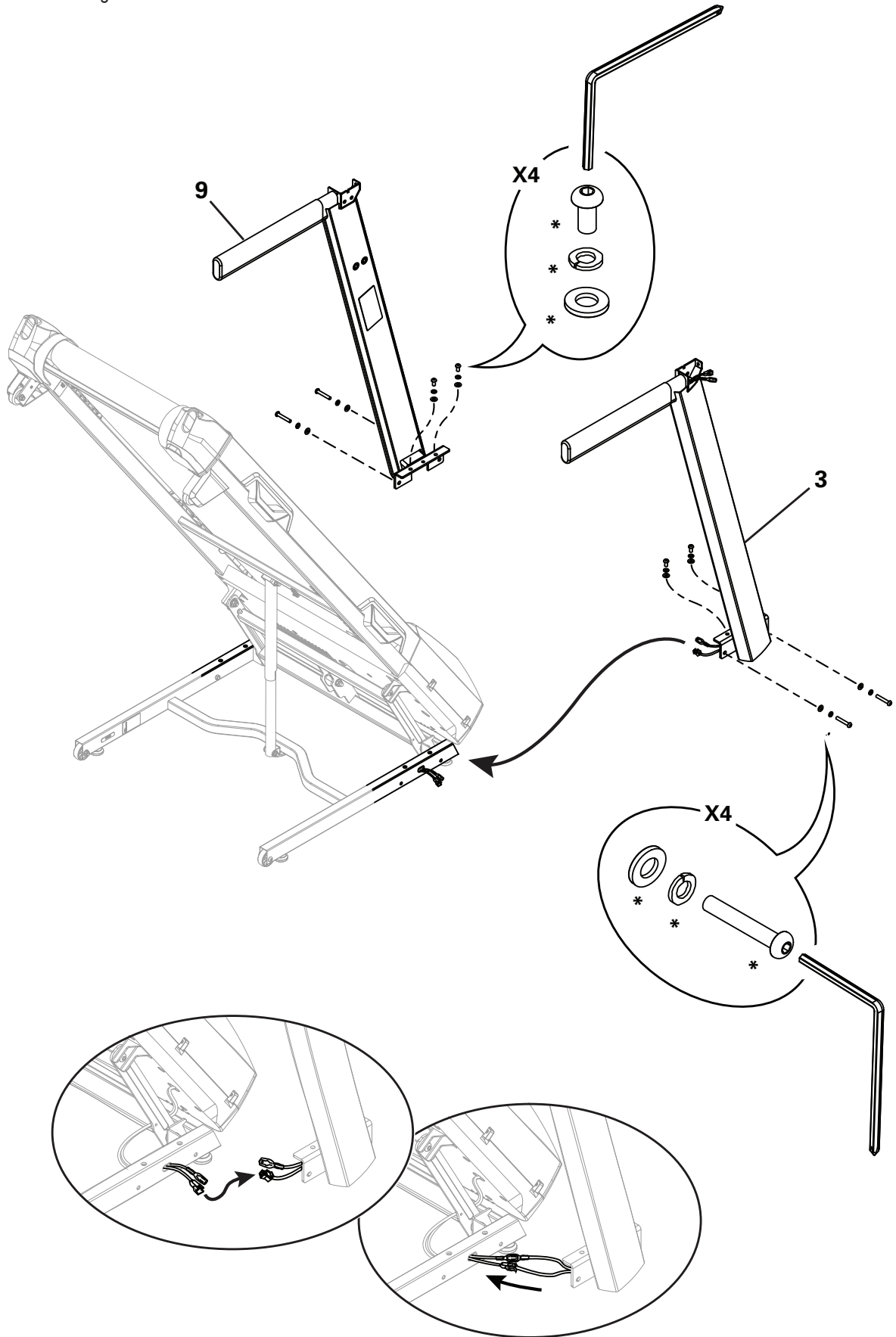

3. Unfold the Walking Deck

Slightly push the walking deck forward toward the front of the machine. With your left foot lightly push the top part of the hydraulic lift forward until the locking tube releases and you can pull the walking deck slightly toward the rear of the machine. Hold up the rear of the walking deck, and move to the side of the machine.

 **Keep clear of the movement path of the walking deck.**

The hydraulic lift is set up to drop lightly. Hold onto the walking deck until approximately 2/3 of the movement down. Make sure that you use proper lifting technique; bend your knees and keep your back straight. The walking deck can possibly drop quickly in the last part of the movement.

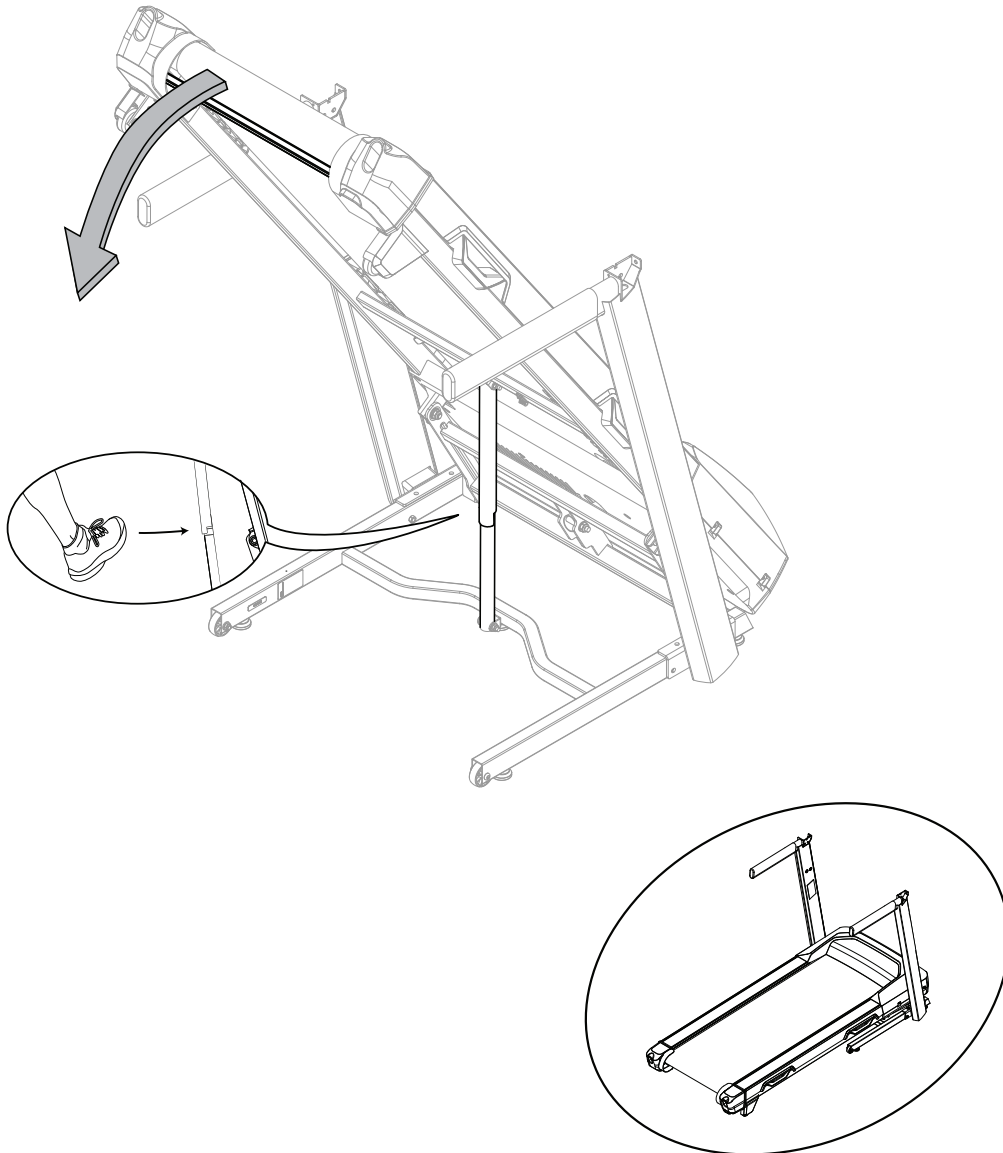

4. Remove the Console Backing from the Console Assembly

Note: Dispose of the pre-installed hardware (*).

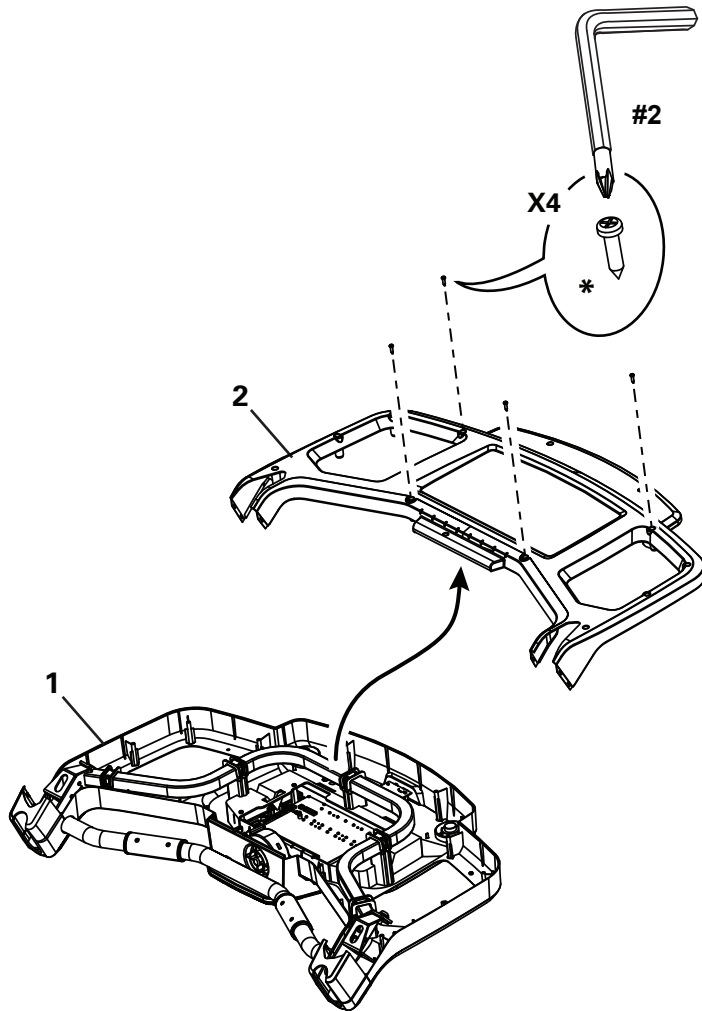

5. Attach the Console to Frame Assembly and Connect the Cables

NOTICE: Be sure that the hooks on each side of the Console are seated in the notches on the Uprights. Remove the ziptie and rubberbands that attach the Cables. Do not pinch or cut the cables. *Hardware is pre-installed, and not supplied in the Hardware Bag. Do not fully tighten Hardware until instructed.

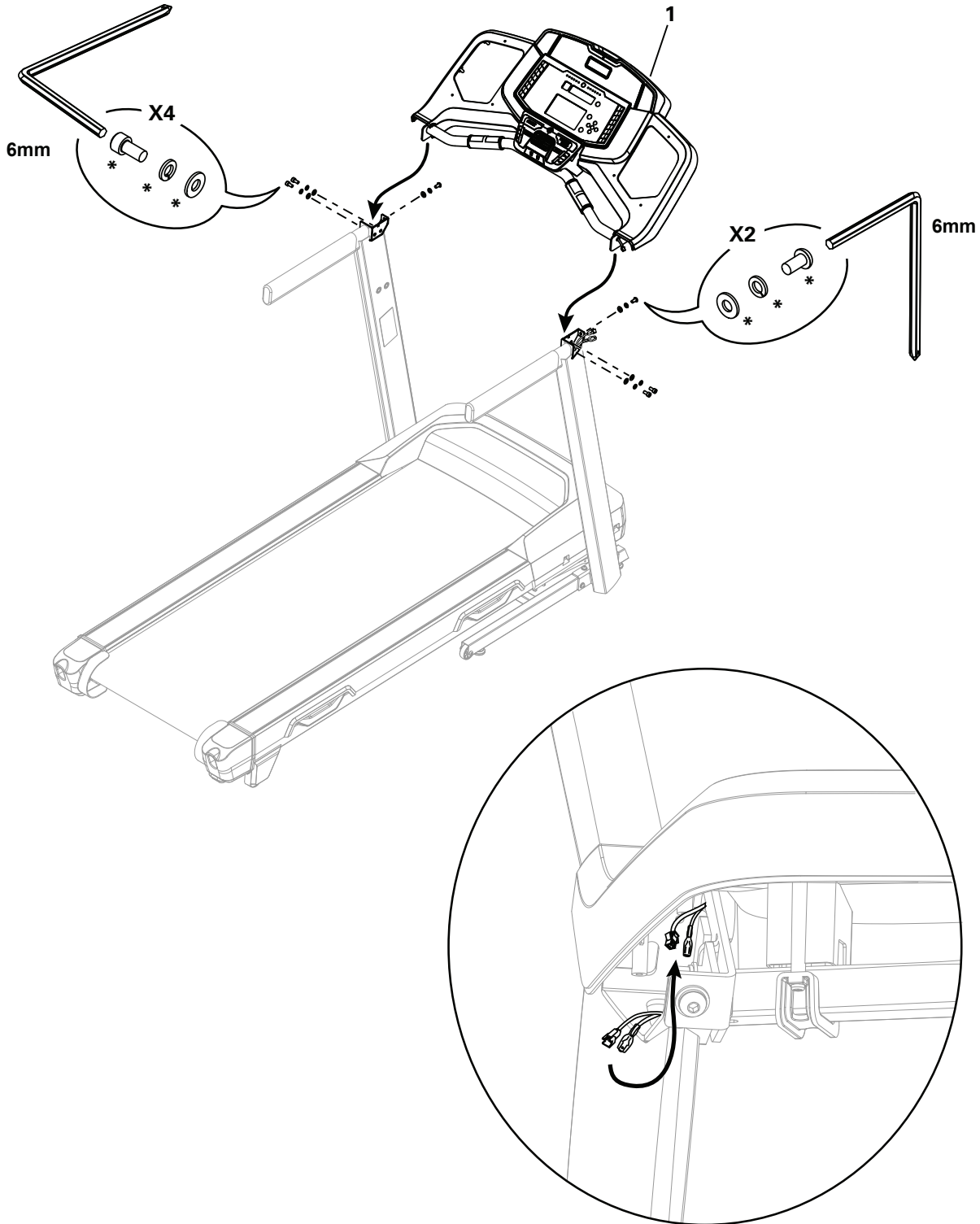

6. Attach the Crossbar to the Uprights

Note: If necessary, loosen the screws from Step 5 to make installation of the Crossbar easier. *Hardware is pre-installed, and not supplied in the Hardware Bag.

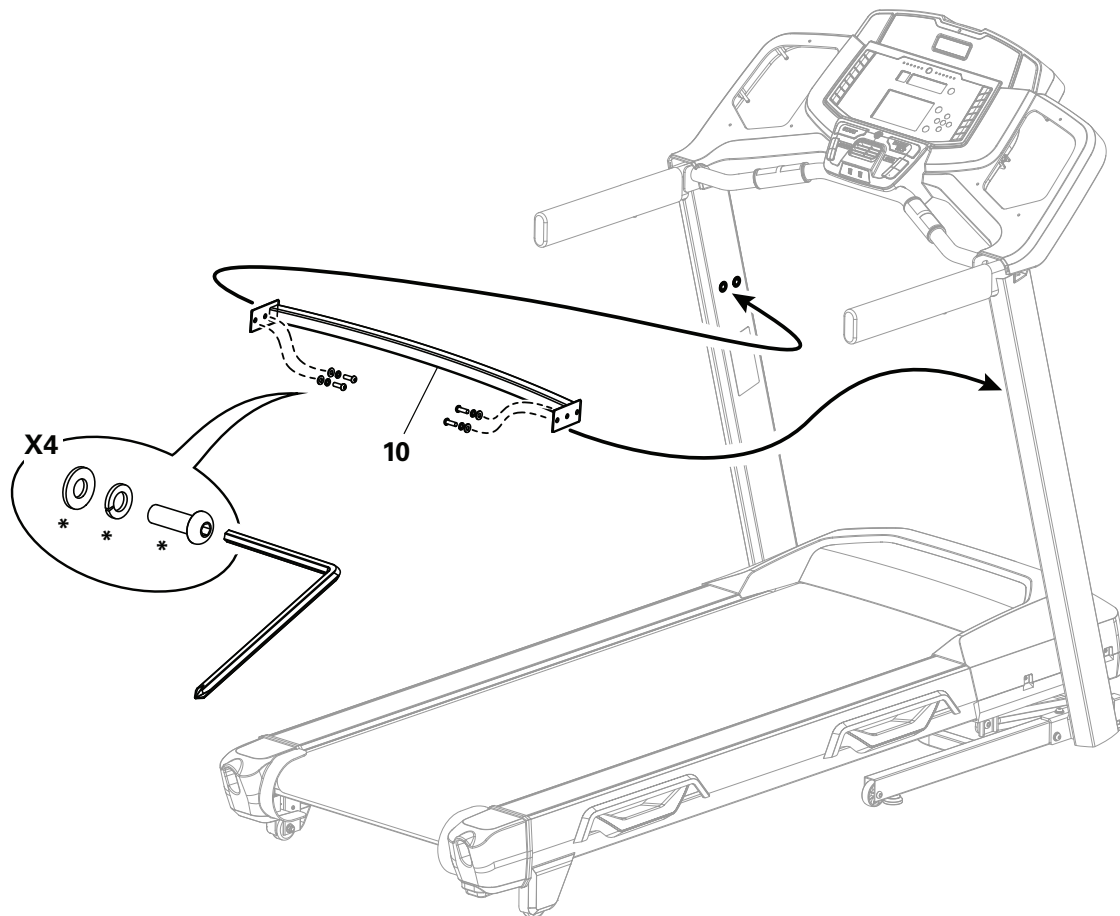

7. Attach the Cupholders to the Console

NOTICE: Cupholder edges should be flush with the face of Console.

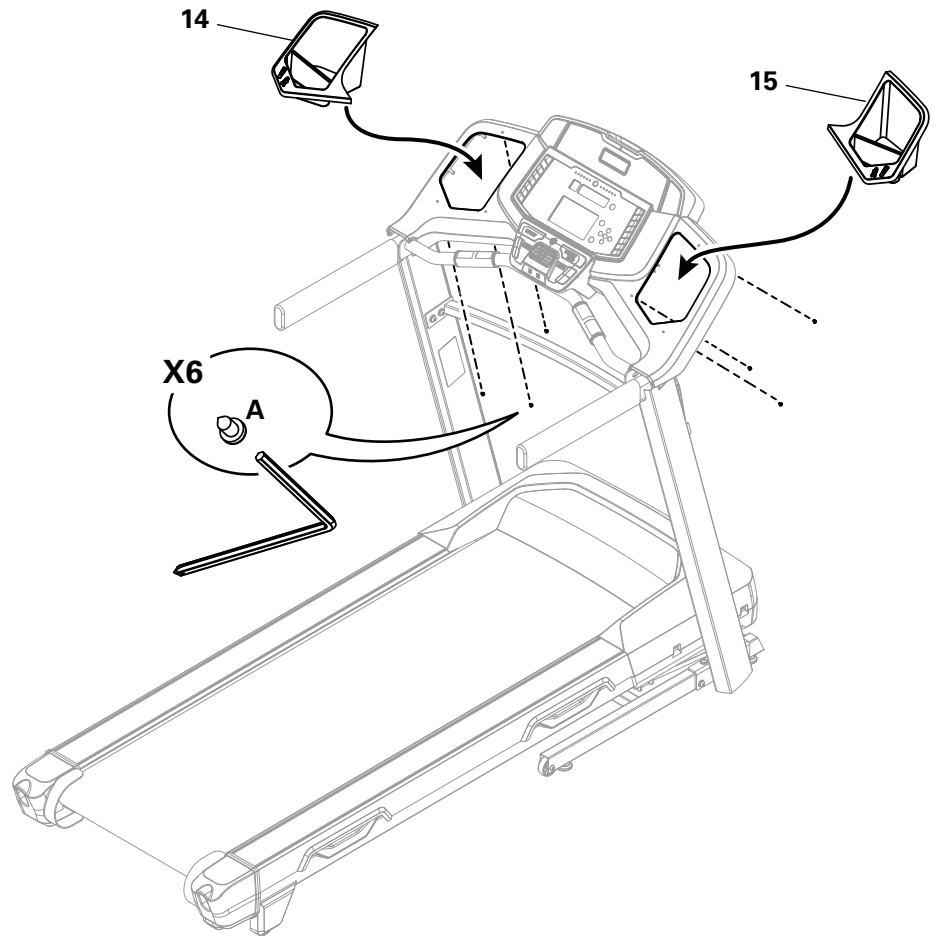

8. Fold the Walking Deck and tighten ALL Hardware from previous steps

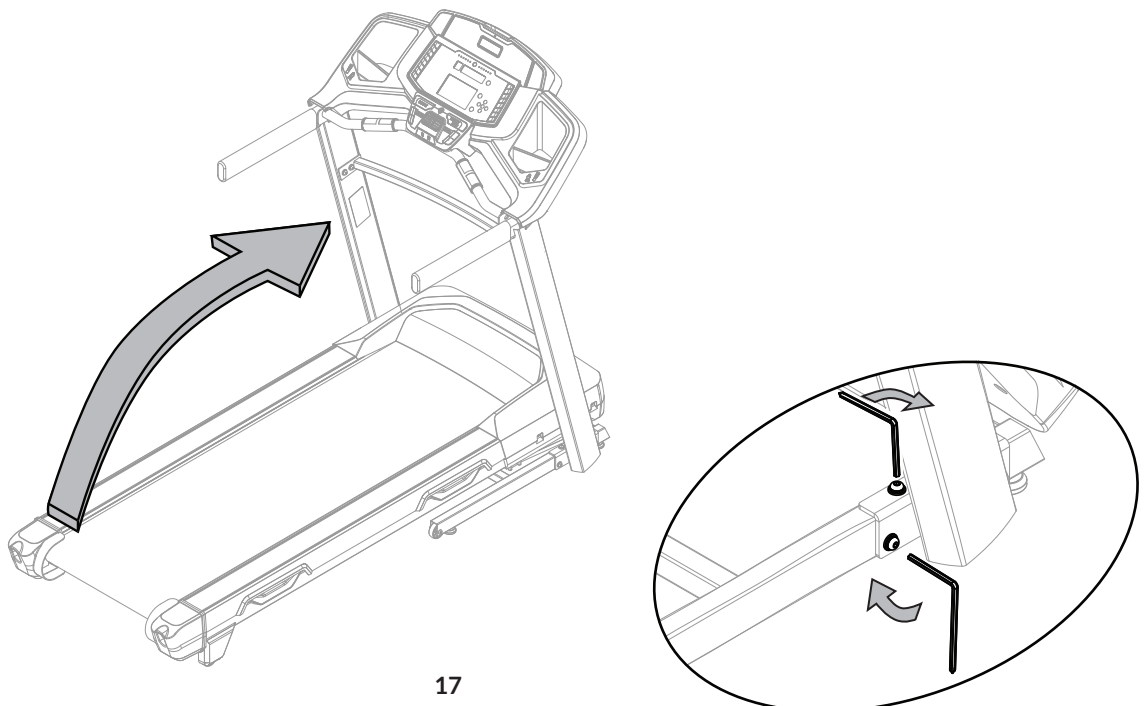

9. Attach the Base Shrouds to the Frame Assembly, and then unfold the Walking Deck

Note: Unfold the Walking Deck after the Base Shrouds have been attached to the Frame Assembly. *Hardware is pre-installed, and not supplied in the Hardware Bag.

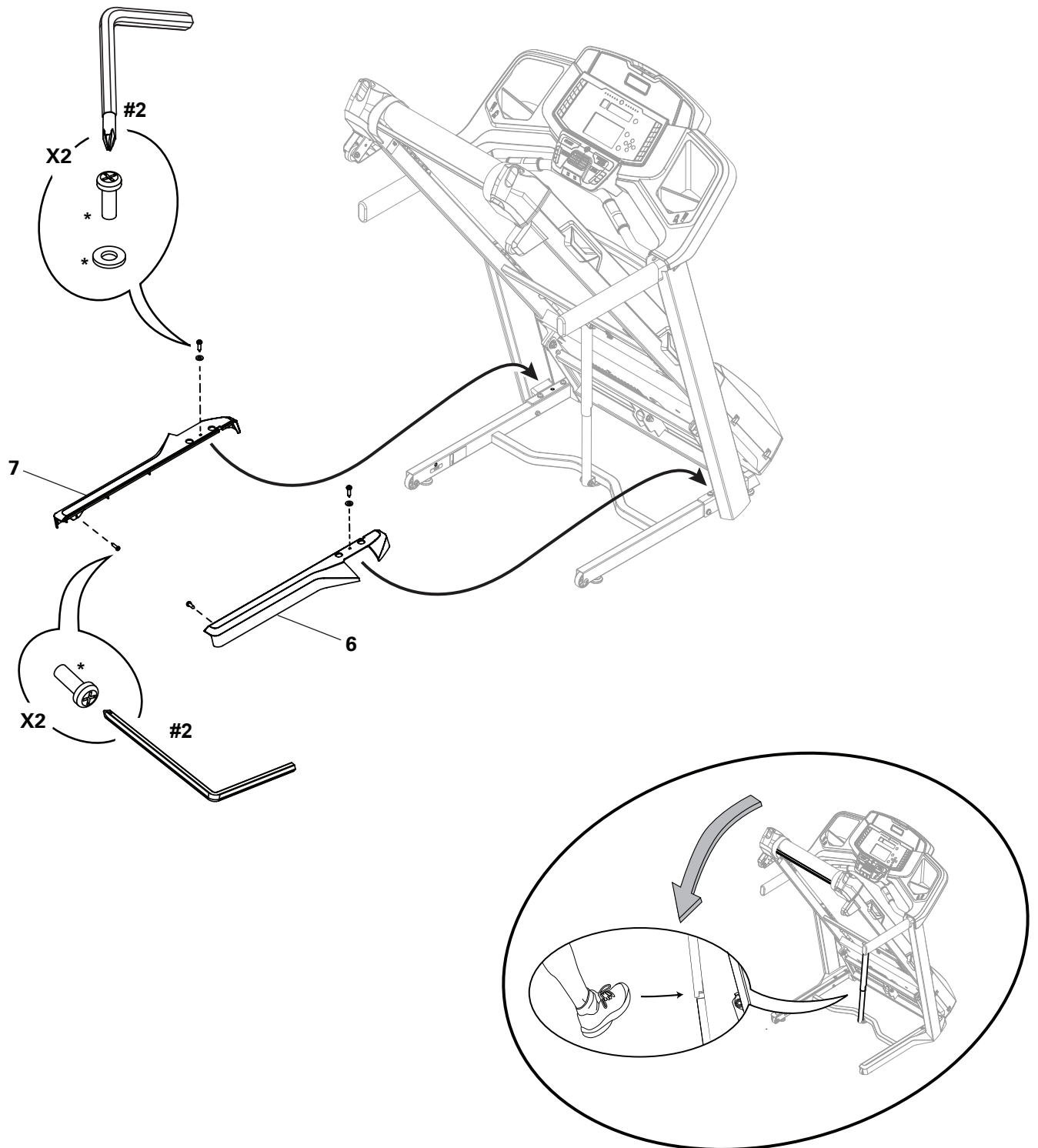

10. Attach the Console Backing to the Console Assembly

NOTICE: Attach the hardware marked below with the (*) first, then the hardware with the (**), followed by the remaining hardware.

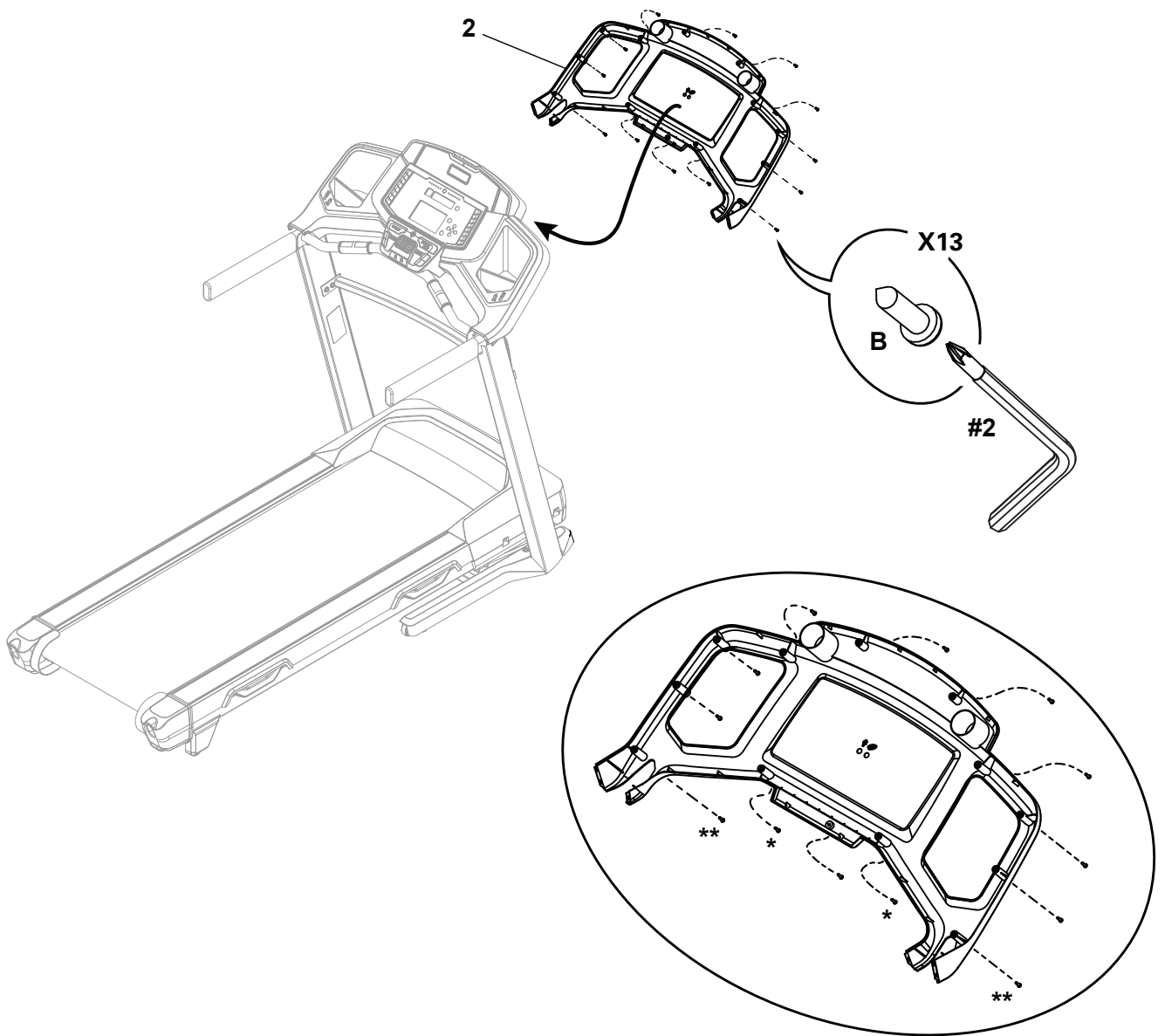

11. Attach the Handlebar Shrouds to the Frame Assembly

Note: Slide the Handlebar Shrouds onto the handlebars and tilt to pass over the remote control buttons. Be sure the tabs on the shrouds snap into the Console.

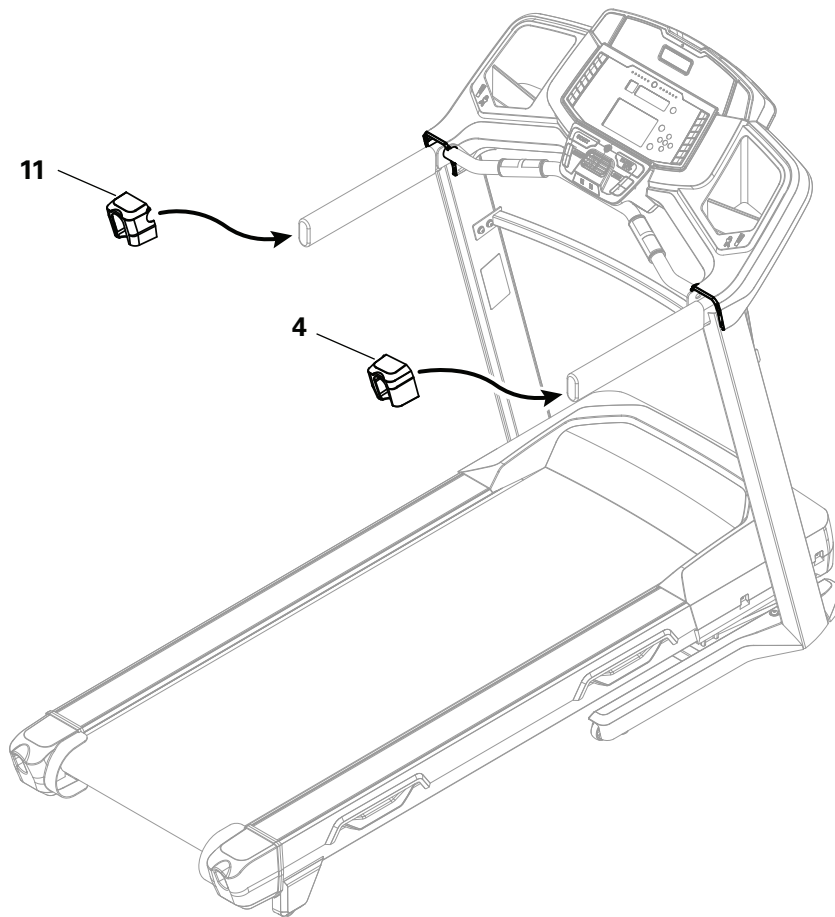

12. Connect the Power Cord and Safety Key to the Frame Assembly

 Connect this machine to a properly grounded outlet only (see Grounding Instructions).

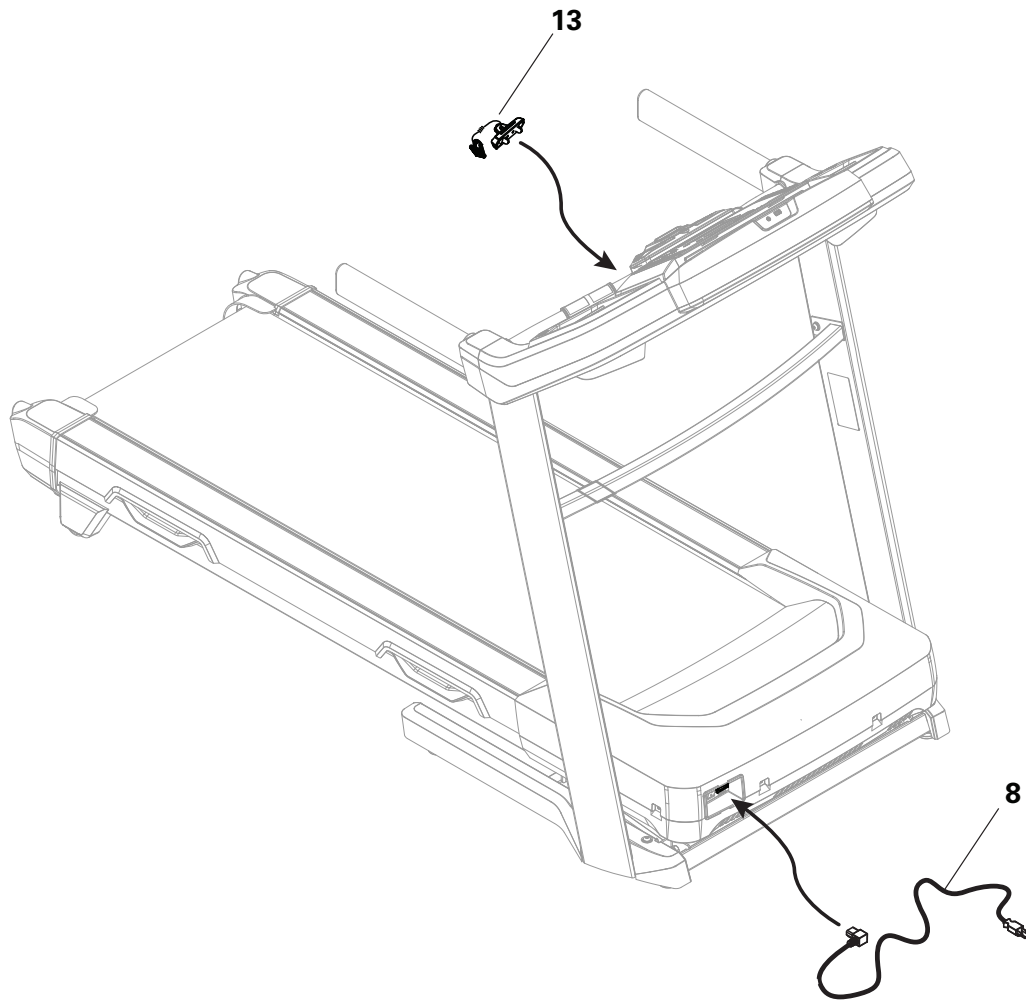

13. Final Inspection

Inspect your machine to ensure that all hardware is tight and components are properly assembled.

Be sure to record the serial number in the field provided at the front of this manual.

 Do not use until the machine has been fully assembled and inspected for correct performance in accordance with the Owner's Manual.

Adjustments

Storage and Moving the Machine

! The machine can be moved by one or more persons. Use caution when you move the machine. The treadmill is heavy and can be awkward. Make sure that your own physical strength is capable of moving the machine. Use a second person if necessary.

1. Before the machine can be moved, inspect the Walking Deck to be sure the Incline setting is at "0". If necessary, adjust the Incline setting to "0".

! Be sure the area below the machine is clear before adjusting the incline of the Deck. Fully lower the incline of the Deck after each workout.

2. Remove the Safety Key and place it in a secure location.

! When this machine is not in operation, remove the Safety Key and keep out of the reach of children.

3. Make sure that the power switch is turned Off, and the power cord is disconnected.

4. You must fold the treadmill before you move it. Never move the treadmill if it is not folded.

! Never move the machine with the Walking Deck not folded. Rotating or moving parts can pinch, resulting in personal injury.

5. Make sure that there is safe clearance around, on and above your treadmill. Make sure there is no object to spill or cause blockage from the fully folded position.

! Be sure there is adequate height clearance for the raised deck.

6. Using the support bar found below the rear of the walking belt, lift the walking deck fully upward and engage the hydraulic lift. Be sure that the hydraulic lift is correctly locked in place.

! Use proper safety precautions and lifting techniques. Bend your knees and elbows, keep your back straight and pull up equally with both arms. Straighten your legs to lift. Make sure that your own physical strength is capable of lifting the walking deck until it engages the locking mechanism. Use a second person if necessary.

Do not use the walking belt or rear roller to lift the treadmill. These parts do not lock in place and can abruptly move. Injury to you or damage to the machine can occur.

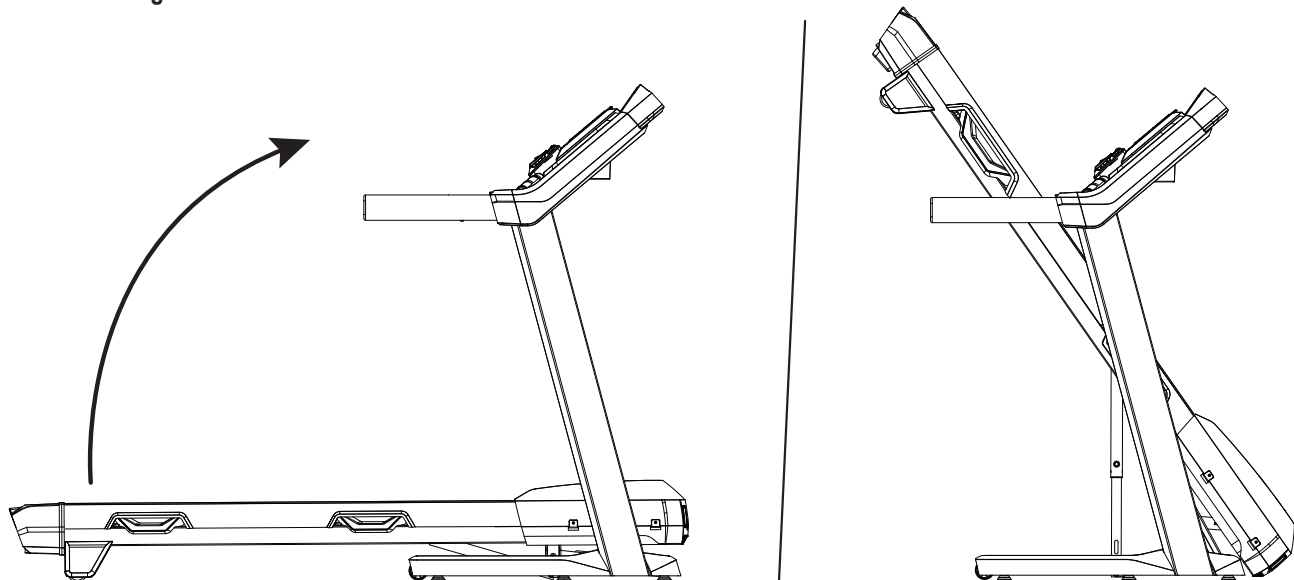

7. Make sure that the locking mechanism is engaged. Carefully pull back on the walking deck and make sure that it does not move. When you do this, keep clear of movement path in case the treadmill lock is not properly engaged.

! Do not lean against the treadmill when it is folded. Do not put items on it that could cause it to become unstable or fall.

Do not connect the power cord or try to operate the treadmill in the folded position.

8. Stand to one side of the treadmill. Place your front foot so it pins the Base Assembly. Grasping the Side Handrail, carefully pivot the treadmill rearward until it is balanced fully on the transport wheels. Be sure not to pivot the machine too far. Hold the treadmill in the balanced position.

! This step may require two persons on each side of the treadmill. The treadmill is heavy and can be awkward. Make sure that your own physical strength is capable of pivoting the machine.

Always wear fully enclosed shoes when moving this machine. Do not move the machine with bare feet or only wearing socks.

Do not use the Console or lifted Walking Deck to pivot or move the treadmill. Injury to you or damage to the machine can occur.

Keep clear of the movement path of the lifted Walking Deck.

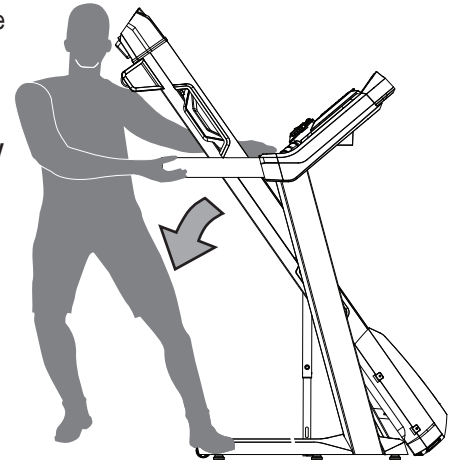

9. Grasping the Side Handrail and the front of the Upright, safely roll the treadmill to the desired location.

! The treadmill is heavy and can be awkward. Make sure that your own physical strength is capable of moving the machine.

Place the machine on a clean, hard, level surface, free from unwanted material or other objects that may hamper your ability to move freely. A rubber mat should be used below the machine to prevent the release of static electricity and protect your flooring.

Do not put objects in the path of the walking deck when lowered.

NOTICE: Move the machine carefully so that it does not hit other objects. This can damage the Console operation, the treadmill, or the area around the machine.

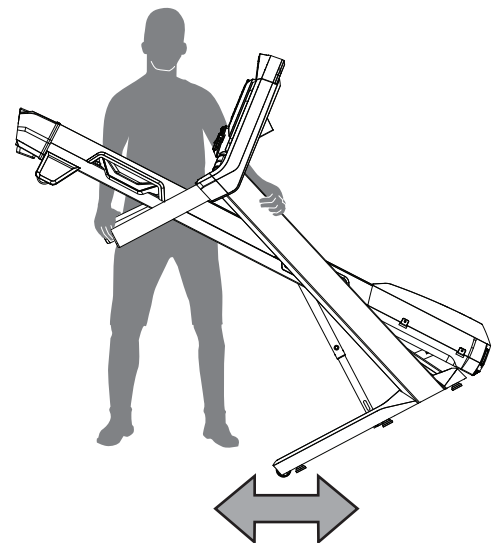

10. Prior to use, refer to the “Unfolding the Machine” procedure in this manual.

Unfolding the Machine

1. Make sure there is sufficient space to lower the walking deck.

! Keep a minimum clearance behind the machine of 2 m (79 in) and 0.5 m (19.7 in) on each side. This is the recommended safe distance for access, movement and emergency dismounts from the machine.

! Place the machine on a clean, hard, level surface, free from unwanted material or other objects that may hamper your ability to move freely with a sufficient clear workout area. A rubber mat below the machine is recommended to prevent electrostatic discharge and protect your floor.

Be sure that the workout space you are utilizing has adequate height clearance, taking into consideration the height of the user and the maximum incline of the deck.

2. Make sure there is no object on or around the treadmill to spill or cause blockage from the fully unfolded position.
3. Slightly push the walking deck forward toward the console. With your left foot lightly push the top part of the hydraulic lift forward until the locking tube releases and you can pull the walking deck away from the console. Hold up the rear of the walking deck, and move to the side of the machine.

! Keep clear of the movement path of the walking deck.

4. The hydraulic lift is set up to drop lightly. Hold onto the walking deck until approximately 2/3 of the movement down. Make sure that you use proper lifting technique; bend your knees and keep your back straight. Lower the weight with your legs. The walking deck can possibly drop quickly in the last part of the movement.

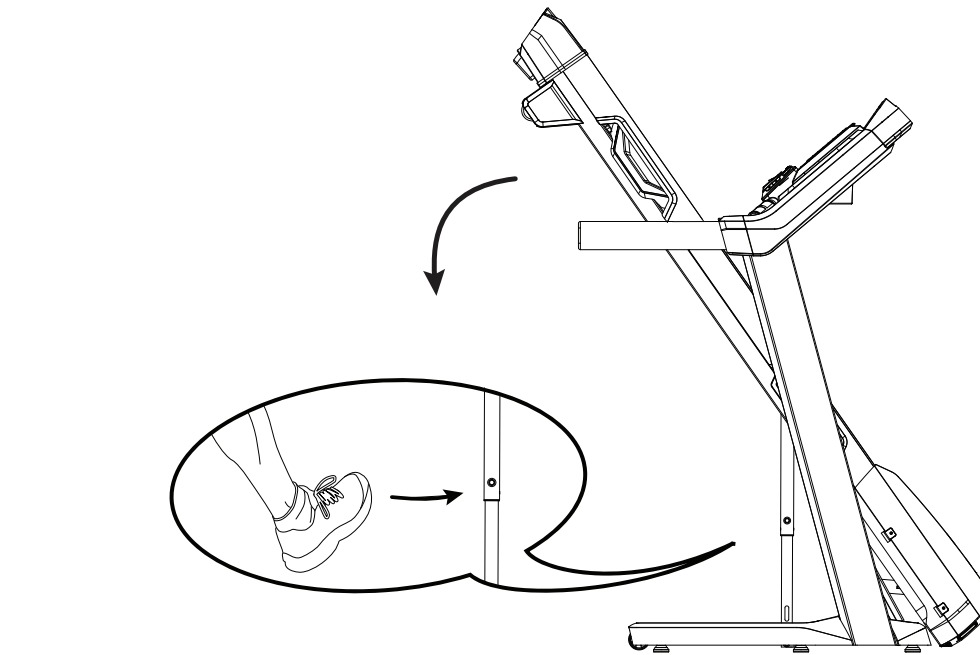

Leveling the Machine

The machine needs to be leveled if your workout area is uneven. To adjust:

1. Place the machine in your workout area.
2. Adjust the levelers until they all contact the floor.

⚠ Do not adjust the levelers to such a height that they detach or unscrew from the machine. Injury to you or damage to the machine can occur.

3. Adjust until the machine is level.

Make sure the machine is level and stable before you exercise.

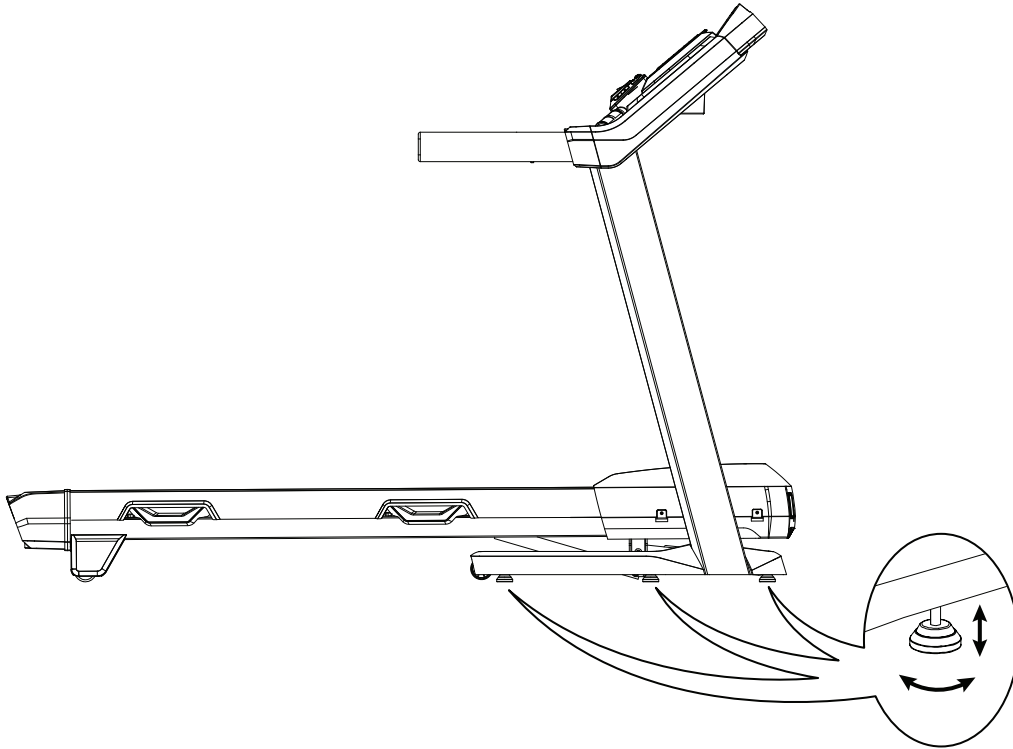

Treadmill Belt

Your treadmill comes equipped with a durable, high quality walking belt designed to provide many hours of reliable service. The walking belt on a treadmill that has not been operated for a length of time, either in factory packaging or after assembly, can exhibit a “thumping” noise when started. This is due to the belt taking on the curve of the front and rear rollers. This is a common occurrence and does not indicate a problem with your machine. After the treadmill has been used for a short period of time the thumping noise will discontinue. The amount of time will vary depending on the temperature and humidity of the environment where the treadmill is placed.

Features

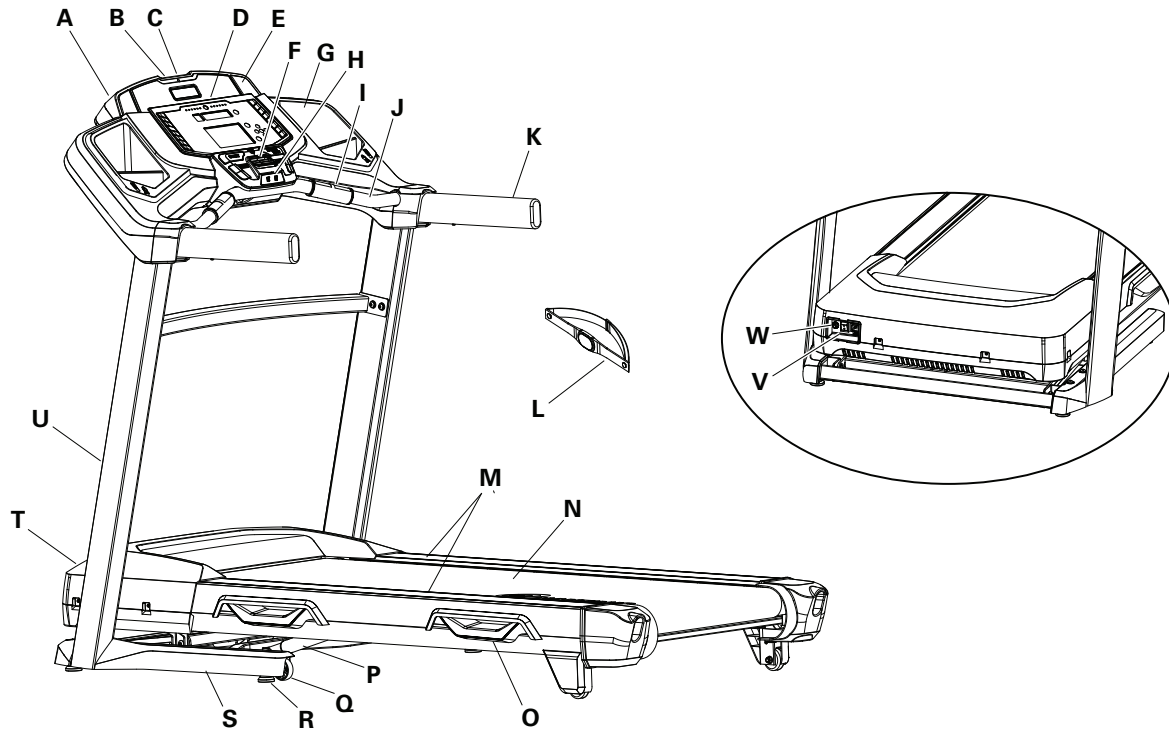

A	Console	N	Walking Belt and Deck
B	USB Port	O	Dampener
C	MP3 Input	P	Hydraulic Lift
D	Media Tray	Q	Transport Wheel
E	Speaker	R	Leveler
F	Fan	S	Base
G	Cupholder	T	Motor Cover
H	Emergency Safety Key Port	U	Uprights
I	Contact Heart Rate (CHR) Sensors	V	Power Switch
J	Ergo Bar	W	AC Inlet
K	Handlebar	X	Telemetry Heart Rate (HR) Receiver (not shown)
L	Heart Rate Chest Strap	Y	Bluetooth® Connectivity (not shown)
M	Side Foot Support Rails	Z	Media Cable (not shown)

⚠ WARNING

Use the values calculated or measured by the machine's computer for reference purposes only. The heart rate displayed is an approximation and should be used for reference only. Over exercising may result in serious injury or death. If you feel faint stop exercising immediately.

Console

The Console provides important information about your workout and lets you control the resistance levels while you exercise. The Console features touch control buttons to navigate you through the exercise programs.

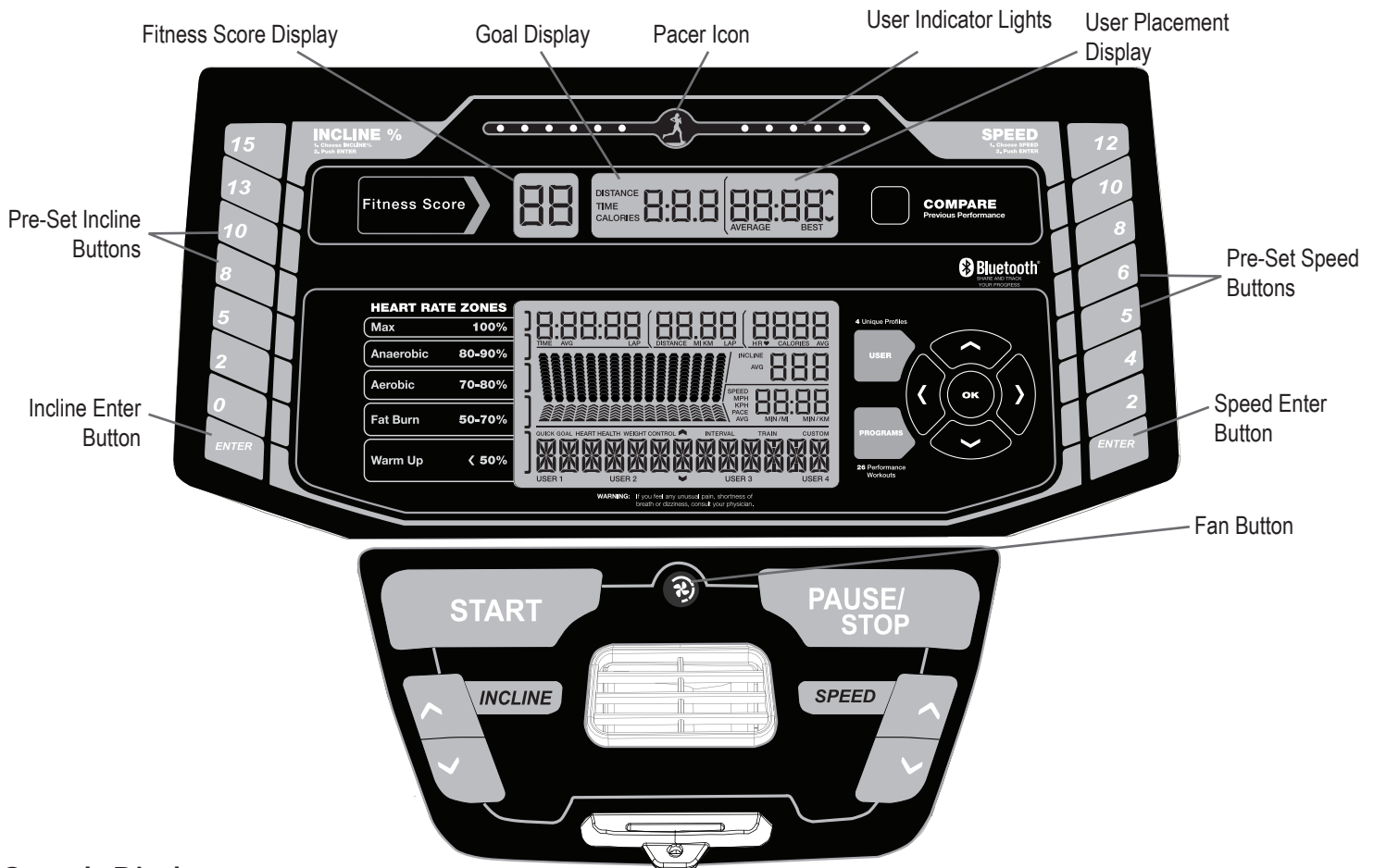

Console Display

Pacer Icon- represents the location of the Pacer during the Workout.

User Indicator Lights- The User indicator lights show where the User is in relation to the Pacer during the Workout.

Fitness Score Display- The Fitness Score Display shows the current Fitness Score of the selected User Profile.

Goal Display-The Goal Display shows the selected type of goal (Distance, Time or Calories) and the value for it.

User Placement Display- The User Placement Display shows the difference between the User and the Pacer. The arrows tell if the User is in front (UP arrow) or behind (DOWN arrow) the Pacer.

COMPARE button- Push to select the desired Workout Pacer: Average, Best, or off.

USER button- Push to select the desired User Profile. The Active User Display will adjust

Increase (▲) button- Increases the current value or moves through the options available

Left (◀) button- Shifts the currently active segment, and moves through options

OK button- Confirms information or a selection

Decrease (▼) button- Decreases the current value, or moves through the options available

Right (►) button- Shifts the currently active segment, and moves through options

PROGRAMS button- Selects a category of workout programs

Pre-Set Incline buttons- Selects an incline value for the Walking Deck. After pushing a Pre-Set Incline button, push the Incline Enter button within 12 seconds for the Walking Deck to be adjusted to the desired incline.

Incline Enter button- Activates the incline motor to adjust the Walking Deck to the selected Pre-Set Incline value.

START button- Begins a Quick Start workout, begins a Program Workout after customized for the User, or resumes a paused workout.

FAN button- Controls 3-speed fan

PAUSE / STOP button- Pauses an active workout, ends a paused workout, or exits to the previous menu

Pre-Set Speed buttons- Selects a speed value for the Walking Belt. After pushing a Pre-Set Speed button, push the Speed Enter button within 12 seconds for the Walking Belt to be adjusted to the desired speed.

Speed Enter button- Adjusts the speed of the Walking Belt to the selected Pre-Set Speed value.

LCD Display Data

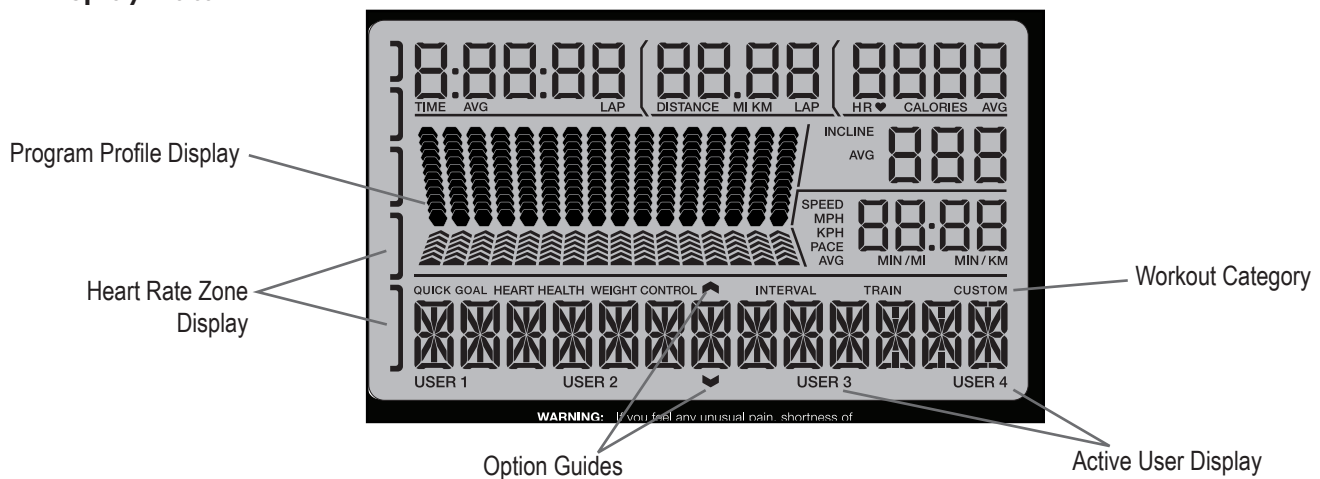

Program Profile Display

The Program Profile Display shows the course profile for the workout program. A course profile has 16 columns, or segments. The course profile has two variables for each segment: incline (hexagons, upper) and speed (arrows, lower).

The more intense the incline or speed setting, the higher the level for that segment. The flashing segment shows your current interval.

Heart Rate Zone Display

The Heart Rate Zone shows which zone the current heart rate value falls into for the current User. These Heart Rate Zones can be used as a workout guide for a certain target zone (max, anaerobic, aerobic, fat burn, and warm up).

⚠️ Consult a physician before you start an exercise program. Stop exercising if you feel pain or tightness in your chest, become short of breath, or feel faint. Contact your doctor before you use the machine again. Use the values calculated or measured by the machine's computer for reference purposes only. The heart rate displayed is an approximation and should be used for reference only.

Note: If no heart rate is detected, the Heart Rate Zone display will be blank.

Option Guides

The Option Guides inform the User where they are in a list of options with the MORE and PREVIOUS Options.

If the MORE Options (decrease arrow) is active, then there are additional options that can be viewed by pushing the Decrease (▼) button. The MORE Options (decrease arrow) is active until the User reaches the end of the list. When the User is at the end of the options list, the MORE Options (decrease arrow) will deactivate and the Decrease (▼) button will not provide further options.

The PREVIOUS Options (increase arrow) is active as soon as the User begins moving through the list. Use the Increase (▲) button to see the previous options.

Active User Display

The Active User Display shows which User Profile is currently selected.

Time / Lap (Time)

The TIME display field shows the total time count of the workout, the average Time for the User Profile, or the total operational time of the machine.

Note: The maximum time for a Quick Start workout is 9 hours, 59 minutes and 59 seconds (9:59:59).

The Lap (Time) display shows the time count for the just completed Lap. During a workout, this workout value is only displayed when a Lap is completed.

Distance / Lap (Count)

The Distance display shows the distance count (miles or km) in the workout.

The Lap (Count) display shows the total number of Laps completed during the workout. During a workout, this workout value is only displayed when a Lap is completed, or during the Workout Results mode (completed Laps only, no decimals).

Note: The distance of a Lap can be customized for each User in the Edit User Profile mode. The default is 0.25 miles (0.4 km).

Heart Rate (HR) / Calories

The Heart Rate display shows the beats per minute (BPM) from the heart rate monitor. When a heart rate signal is received by the Console, the icon will flash.

 **Consult a physician before you start an exercise program. Stop exercising if you feel pain or tightness in your chest, become short of breath, or feel faint. Contact your doctor before you use the machine again. The heart rate displayed is an approximation and should be used for reference only.**

Calories

The Calories display field shows the estimated calories that you have burned during the workout.

Incline

The Incline display shows the current percent of Incline for the Walking Deck.

Speed / Pace

The Speed display field shows the belt speed in miles per hour (mph) or kilometers per hour (km/h).

The Pace display field shows the current time to complete a mile (or km) at the current Speed value.

Note: The maximum value for the Pace field is 99:59.

Using your JRNY™ membership with your machine

If you have a JRNY™ membership*, it can be accessed through your device when synced to the console of this Bowflex™ machine. With a JRNY™ membership, you receive guided workouts adapted to your capabilities, conveniently displayed on your device, and friendly virtual voice coaching designed to support you on your journey to long-term fitness success.

1. Download the app, named “Bowflex™ JRNY™”. The app is available on the App Store and Google Play™.
2. Be sure that the Bluetooth® and Location Settings are active on your device. Activate them if necessary.
3. Open the app near the machine, and follow the instructions to sync your device to the machine.

If the app will not sync to the machine, restart your device and the machine. Repeat Step 3.

Workout with Other Fitness Apps

This fitness machine has integrated Bluetooth® connectivity which allows it to work with a number of digital partners. For our latest list of supported partners, please visit: www.nautilus.com/partners

USB Charging

If a USB Device is attached to the USB Port, the Port will attempt to charge the Device. The power supplied from the USB Port may not be enough to operate the Device and charge it at the same time.

Chest Strap

Using the provided heart rate transmitter chest strap lets you monitor your heart rate at any time during your workout.

⚠ Consult a physician before you start an exercise program. Stop exercising if you feel pain or tightness in your chest, become short of breath, or feel faint. Contact your doctor before you use the machine again. The heart rate displayed is an approximation and should be used for reference only.

The heart rate transmitter is attached to a chest strap to keep your hands free during your workout. To put on your chest strap:

1. Attach the transmitter to the elastic chest strap.
2. Secure the strap around your chest with the curve of the transmitter oriented upward, just below the chest muscles.
3. Lift the transmitter off your chest and moisten the two Grooved Electrode Areas on the back.
4. Check that the wet electrode areas are firmly against your skin.

The transmitter will send your heart rate to the machine’s receiver and display your estimated Beats Per Minute (BPM).

Always remove the transmitter before you clean the chest strap. Clean the chest strap regularly with mild soap and water, and thoroughly dry it. Residual sweat and moisture may keep the transmitter active and drain the battery in the transmitter. Dry and wipe clean the transmitter after each use.

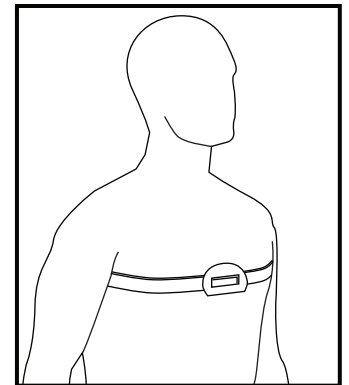

* A JRNY™ membership is required for the JRNY™ experience – see www.bowflex.com/jrny for details. For United States and Canada customers, you can obtain a JRNY™ membership by calling 800-269-4126 or visiting www.bowflex.com/jrny. Where available (including the United States), you can also obtain a JRNY™ membership by downloading the JRNY™ app onto your phone or tablet and signing up within the downloaded app. JRNY™ memberships may not be available in all countries.

Note: Do not use abrasives or chemicals such as steel wool or alcohol when you clean the chest strap, as they can damage the electrodes permanently.

If the Console does not display a heart rate value, the transmitter may be at fault. Check that the textured contact areas on the chest strap are making contact with your skin. You may need to lightly wet the contact areas. Check that the curve of the transmitter is oriented upward. If no signal appears or you need further assistance, call your Nautilus Representative.

 **Before discarding a chest strap, remove the battery. Dispose of in accordance with local regulations and/or at approved recycling centers.**

Remote Heart Rate Monitor

Monitoring your Heart Rate is one of the best procedures to control the intensity of your exercise. Contact Heart Rate (CHR) sensors are installed to send your heart rate signals to the Console. The Console can also read telemetry HR signals from a Heart Rate Chest Strap Transmitter that operates in the 4.5kHz - 5.5kHz range.

Note: The heart rate chest strap must be an uncoded heart rate strap from Polar Electro or an uncoded POLAR® compatible model. (Coded POLAR® heart rate straps such as POLAR® OwnCode® chest straps will not work with this equipment.)

 **If you have a pacemaker or other implanted electronic device, consult your doctor before using a wireless chest strap or other telemetric heart rate monitor.**

Contact Heart Rate Sensors

Contact Heart Rate (CHR) sensors send your heart rate signals to the Console. The CHR sensors are the stainless steel parts of the Handlebars. To use, put your hands comfortably around the sensors. Be sure that your hands touch both the top and the bottom of the sensors. Hold firm, but not too tight or loose. Both hands must make contact with the sensors for the Console to detect a pulse. After the Console detects four stable pulse signals, your initial pulse rate will be shown.

Once the Console has your initial heart rate, do not move or shift your hands for 10 to 15 seconds. The Console will now validate the heart rate. Many factors influence the ability of the sensors to detect your heart rate signal:

- Movement of the upper body muscles (including arms) produces an electrical signal (muscle artifact) that can interfere with pulse detection. Slight hand movement while in contact with the sensors can also produce interference.
- Calluses and hand lotion may act as an insulating layer to reduce the signal strength.
- Some Electrocardiogram (EKG) signals generated by individuals are not strong enough to be detected by the sensors.
- The proximity of other electronic machines can generate interference.

If your heart rate signal ever seems erratic after validation, wipe off your hands and the sensors and try again.

Heart Rate Calculations

Your maximum heart rate usually decreases from 220 Beats Per Minute (BPM) in childhood to approximately 160 BPM by age 60. This fall in heart rate is usually linear, decreasing by approximately one BPM for each year. There is no indication that training influences the decrease in maximum heart rate. Individuals of the same age could have different maximum heart rates. It is more accurate to find this value by completing a stress test than by using an age related formula.

Your at-rest heart rate is influenced by endurance training. The typical adult has an at rest heart rate of approximately 72 BPM, whereas highly trained runners may have readings of 40 BPM or lower.

The Heart Rate table is an estimate of what Heart Rate Zone (HRZ) is effective to burn fat and improve your cardiovascular system. Physical conditions vary, therefore your individual HRZ could be several beats higher or lower than what is shown.

The most efficient procedure to burn fat during exercise is to start at a slow pace and gradually increase your intensity until your heart rate reaches between 50 – 70% of your maximum heart rate. Continue at that pace, keeping your heart rate in that target zone for over 20 minutes. The longer you maintain your target heart rate, the more fat your body will burn.

The graph is a brief guideline, describing the generally suggested target heart rates based on age. As noted above, your optimal target rate may be higher or lower. Consult your physician for your individual target heart rate zone.

Note: As with all exercises and fitness regimens, always use your best judgment when you increase your exercise time or intensity.

FAT-BURNING TARGET HEART RATE

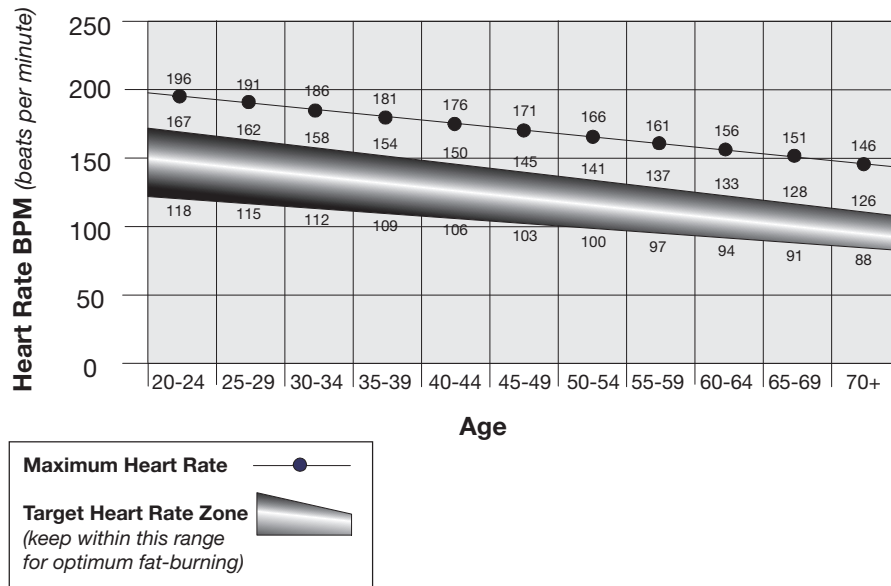

Fitness Basics

Frequency

To maintain good health, lose weight and improve your cardiovascular endurance, try and use the Bowflex™ fitness machine a minimum of 3 times per week, 30 minutes each day.

If you are new to exercise (or returning to a regular exercise program), and you are unable to comfortably complete 30 minutes of continuous exercise at one time, just do 5 – 10 minutes, and gradually increase your workout time until you can reach 30 minutes total.

If your schedule is busy, and you are unable to fit 30 minutes of continuous exercise into your day, try accumulating 30 minutes by doing multiple shorter workouts on the same day. For example, 15 minutes in the morning and 15 minutes in the evening.

For best results, combine your Bowflex™ fitness machine workouts with a strength training program using a Bowflex™ home gym or Bowflex™ SelectTech™ dumbbells, and follow the Bowflex™ Body Weight Loss Guide that is included in this manual.

Consistency

Busy work schedules, family obligations and daily chores can make it difficult to fit regular exercise into your life. Try these tips to increase your chances of success:

Schedule your workouts the same way you schedule meetings or appointments. Select specific days and times each week, and try not to change your workout times.

Make a commitment to a family member, friend or spouse, and encourage each other to stay on track each week. Leave messages with friendly reminders to be consistent, and keep each other accountable.

Make your workouts more interesting by alternating between steady state (single-speed) workouts and interval training (varied speed) workouts. The Bowflex™ fitness machine is even more fun when you add this kind of variety.

Apparel

It is important to wear appropriate, safe and comfortable footwear and clothing when using the Bowflex™ fitness machine, including:

- Rubber-soled athletic walking or running shoes.
- Exercise clothing that allows you to move freely, and keep comfortably cool.
- Athletic support that provides stability and comfort.

 **Do not wear loose clothing or jewelry. This machine contains moving parts. Do not put fingers, feet, or other objects into moving parts of the exercise equipment.**

Always wear rubber soled athletic shoes when you use this machine. Do not use the machine with bare feet or only wearing socks.

Warm-Up*

Before you use your Bowflex™ fitness machine, consider doing these dynamic warm-up stretches, which will help prepare your body for the workout:

* Source: Blahnik, Jay. *Full-Body Flexibility, 2nd Edition*. Champaign, IL: Human Kinetics, 2010. HumanKinetics.com

Dynamic Knee Hug

Stand with the feet together. Bring one knee forward and up toward the chest. Place the hands around the shin and pull the knee into the chest. Release the stretch by putting the foot on the floor. Each repetition of the sequence should take 1 to 3 seconds. Repeat as a continuous, controlled, fluid sequence 10 or 20 times. Repeat the stretch with the other leg.

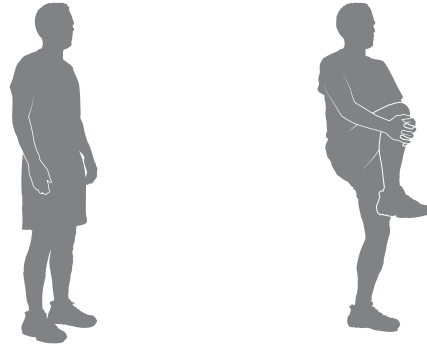

Dynamic Knee Bend

Stand with the feet together. Raise the heel of one foot toward the gluteals. Release the stretch by putting the foot on the floor. Each repetition of the sequence should take 1 to 3 seconds. Repeat as a continuous, controlled, fluid sequence 10 or 20 times. Repeat the stretch with the other leg.



Dynamic Knee Kick

Stand tall and hold one leg up with the hands at hip height, keeping the knee bent. Hold onto a wall for balance with one hand, if necessary. Straighten the knee as far as comfortably possible. Release the stretch by bending the knee. Each repetition of the sequence should take 1 to 3 seconds. Repeat as a continuous, controlled, fluid sequence 10 or 20 times. Repeat the stretch with the other leg.

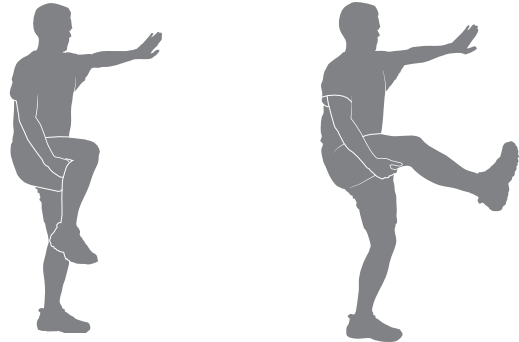

Dynamic Twist

Stand with the feet shoulder-width apart. Bend the elbows; hold the arms out to the sides. Twist the upper body to one side and then the other side as far as comfortably possible. Each repetition of the sequence should take 1 to 3 seconds. Repeat as a continuous, controlled, fluid sequence 10 or 20 times.

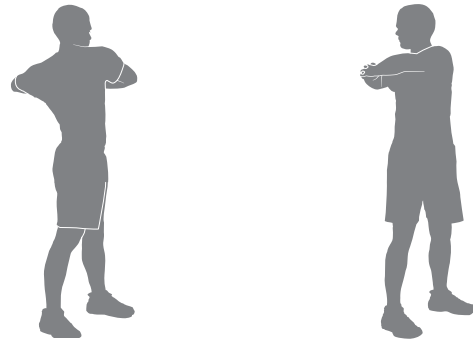

Dynamic Bent Knee Heel Press

Stand with one foot forward and one foot back, hip-width apart and feet facing forward. Bend both knees putting weight on the back heel. Release the stretch by returning to the start position. Each repetition of the sequence should take 1 to 3 seconds. Repeat as a continuous, controlled, fluid sequence 10 or 20 times. Repeat the stretch with the other leg. Touch a wall or hold onto something for balance, if necessary.

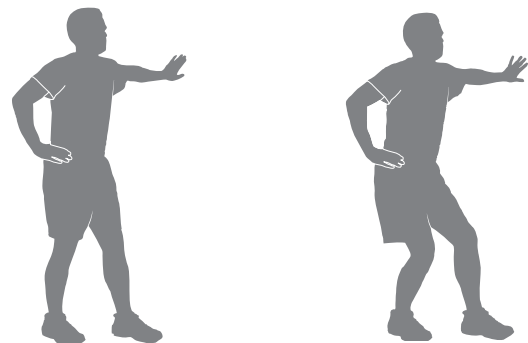

Dynamic Side Reach

Stand with the feet apart, the knees slightly bent and the arms at the sides of the body. Reach with one hand above the head and lean over to the opposite side. Release the stretch by returning to the start position. Then reach with the other hand to the opposite side. Use the other arm to support the body weight on the thigh, if necessary. Each repetition of the sequence should take 1 to 3 seconds. Repeat as a continuous, controlled, fluid sequence 10 or 20 times.

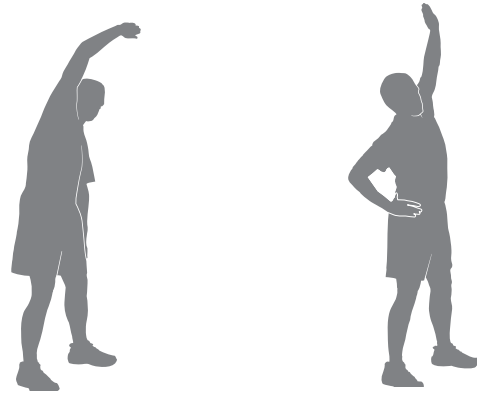

Workouts

Follow these guidelines to ease yourself into a weekly exercise regimen. Use your judgment and/or the advice of your physician or health care professional to find the intensity and level of your workouts.

⚠️ Consult a physician before you start an exercise program. Stop exercising if you feel pain or tightness in your chest, become short of breath, or feel faint. Contact your doctor before you use the machine again. Use the values calculated or measured by the machine's computer for reference purposes only.

Steady State and Interval Training are 2 types of workouts you can do on your Bowflex™ fitness machine:

Steady State workouts

A Steady State workout involves slowly increasing your workout speed to a challenging, but comfortable speed you can hold for most of your workout. For example, holding a 3.0 MPH walking pace for the entire workout, except during the warm-up and cool-down. Steady State workouts help you build exercise confidence, stamina and endurance, and are essential to a well-rounded cardiovascular training program.

Interval Training workouts

An Interval Training workout involves adjusting your speed faster and slower for specific lengths of time to raise and lower your breathing rate, heart rate and calorie burn. Here is a sample Interval Training workout:

- 7 minutes walking at a slow, easy, comfortable speed.
- 1 minute walking at a more challenging speed that is approximately 50% faster.
- 7 minutes walking at a slow, easy, comfortable speed.
- 1 minute walking at a more challenging speed that is approximately 2x faster.
- 7 minutes walking at a slow, easy, comfortable speed.
- 1 minute walking at a more challenging speed that is approximately 50% faster.
- 6 minutes walking at a slow, easy, comfortable speed.

Interval training workouts provide variety and can help you to improve fitness.

The Bowflex™ fitness machine is designed to cushion your joints and muscles, and both Steady State and Interval Training workouts should feel more comfortable than walking or running outside on a hard surface.

Workout Schedule

Here is a beginner, intermediate and advanced sample workout schedule. Use the workout schedule that reflects your current fitness level. With each of these sample workout schedules, do not move on to the next week until the current week feels easier and comfortable.

Beginner	Week 1	Week 2	Week 3	Week 4	Week 5
Workout 1	Steady State	Steady State	Steady State	Interval Training	Interval Training
Workout 2	Steady State	Steady State	Interval Training	Steady State	Steady State
Workout 3	Steady State	Steady State	Steady State	Interval Training	Interval Training

Intermediate	Week 1	Week 2	Week 3	Week 4	Week 5
Workout 1	Steady State	Steady State	Interval Training	Steady State	Interval Training
Workout 2	Steady State	Interval Training	Steady State	Interval Training	Steady State
Workout 3	Steady State	Steady State	Interval Training	Steady State	Interval Training

Advanced	Week 1	Week 2	Week 3	Week 4	Week 5
Workout 1	Steady State	Interval Training	Interval Training	Interval Training	Interval Training
Workout 2	Interval Training	Steady State	Steady State	Steady State	Interval Training
Workout 3	Steady State	Interval Training	Interval Training	Interval Training	Interval Training



Cool-Down *

When you are done using your Bowflex™ fitness machine, consider doing these relaxing stretches, which will help your body recover from the work-out and make you more flexible:

Lying Leg Raise

Lie on the floor face up with the legs slightly bent. Lift one leg up toward the ceiling, keeping the knee straight. Place the hands (or a strap) around the thigh and move the leg closer to the head. Hold the stretch for 10 to 30 seconds. Repeat the stretch on the other leg. Keep the head on the floor and do not round the spine.

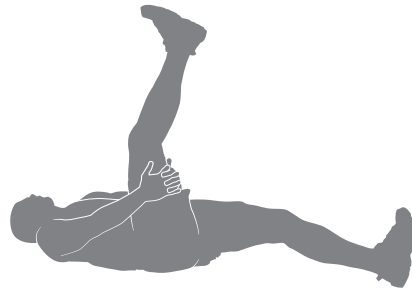

Side Lying Knee Bend

Lie on the floor on one side of the body and rest the head on the lower arm. Bend the top knee and hold the ankle with the same-side hand, then pull the heel toward the gluteals. Hold the stretch for 10 to 30 seconds. Lie on the other side and repeat the stretch with the other leg. Remember to hold the knees close together.

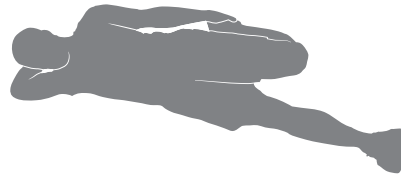

Lying Figure Four

Lie on the floor face up with the legs bent. Place one foot across the thigh of the opposite leg in the figure four position. Reach for the leg on the floor and pull it toward the chest. Hold the stretch for 10 to 30 seconds. Repeat the stretch with the other leg. Keep the head on the floor.

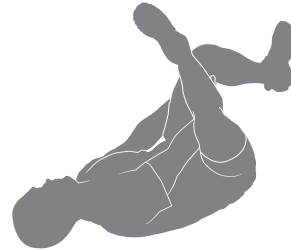

Seated Twist

Sit on the floor and extend the legs straight out in front of the body with the knees slightly bent. Place one hand on the floor behind the body and the other hand across the thigh. Twist the upper body as far as comfortably possible to one side. Hold the stretch for 10 to 30 seconds. Repeat the stretch on the other side.



Seated Figure Four

Sit on the floor and extend one leg straight out in front of the body. Place the foot of the other leg across the thigh in the figure four position. Move the chest toward the legs, pivoting at the hip. Hold the stretch for 10 to 30 seconds. Repeat on the other leg. Use the arms to support the back.



* Source: Blahnik, Jay. *Full-Body Flexibility, 2nd Edition*. Champaign, IL: Human Kinetics, 2010. HumanKinetics.com

Dynamic Heel Drop

Place the ball of one foot on the edge of a step or staircase. Place the other foot slightly in front. Lower the heel of the back foot as far as comfortably possible, keeping the knee straight. Release the stretch by lifting the heel as high as comfortably possible. Each repetition of the sequence should take 1 to 3 seconds. Repeat as a continuous, controlled, fluid sequence 10 or 20 times. Repeat the stretch with the other leg

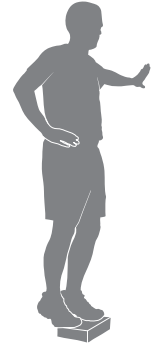

Operations

What to Wear

Wear rubber-soled athletic shoes. You will need the appropriate clothes for exercise that allow you to move freely.

How Often Should You Exercise

! Consult a physician before you start an exercise program. Stop exercising if you feel pain or tightness in your chest, become short of breath, or feel faint. Contact your doctor before you use the machine again. Use the values calculated or measured by the machine's computer for reference purposes only. The heart rate displayed on the console is an approximation and should be used for reference only.

- 3 times a week for 30 minutes each day.
- Schedule workouts in advance and try to follow the schedule.
- Consider doing some warm-up stretches, which will help prepare your body, before your workouts.

Getting Started

! Consult a physician before you start an exercise program. Stop exercising if you feel pain or tightness in your chest, become short of breath, or feel faint. Contact your doctor before you use the machine again. Use the values calculated or measured by the machine's computer for reference purposes only.

Place the machine on a clean, hard, level surface, free from unwanted material or other objects that may hamper your ability to move freely with a sufficient clear workout area. A rubber mat below the machine is recommended to prevent electrostatic discharge and protect your floor.

Be sure that the workout space you are utilizing has adequate height clearance, taking into consideration the height of the user and the maximum incline of the deck.

1. With the fitness machine in your workout area, inspect the walking belt to make sure it is centered and aligned. If necessary, refer to the "Aligning the Walking Belt" Procedure in the Maintenance section of this manual.

Note: This machine is for home use only.

2. Examine below the walking belt for any objects. Be sure it is clear below the machine.
3. Connect the Power Cord to a correctly grounded AC wall outlet.

! Do not step on the power cord and plug.

Note: The machine is designed to plug directly into a properly wired and grounded three prong 120V outlet.

4. If you use the Remote Heart Rate Monitor, follow the Chest Strap directions.
5. Switch on the power. Power is now supplied to the machine.
6. Straddle the walking belt and stand on the Side Foot Support Platforms. Put the Safety Key into the Safety Key Port and clip the Safety Key cord to your clothing.

! Care should be used when mounting or dismounting the machine.

To prevent injury, stand on the Foot Platforms before you start the machine or end a workout. Do not dismount the machine by standing on the moving Walking Belts and exiting off the rear of the unit (or machine).

- Examine the Safety Key and be sure it is connected to the Console correctly.

Note: If the Safety Key is not installed, the machine will allow the User to perform all activities except to activate the Walking Belt. The Console will display the reminder to insert the Safety Key (" + SAFETY KEY").

- Always attach the Safety Key Clip to your clothing during workouts.
 - If there is an emergency, pull out the Safety Key to shut off the power to the Belt and Incline Motors. This will quickly stop the belt (brace yourself- this is an abrupt stop) and clear the workout. Push the PAUSE/STOP button to stop the belt and pause the program.
7. Push the USER button to select the desired User for the workout.

8. Select your workout using the PROGRAMS button and the Decrease/Increase buttons.
9. With your desired workout shown, push the OK button.
10. The Console will ask a series of questions to customize the workout. When the Console displays the “READY ?” prompt, push the START button. The Console will display “RAMPING UP” as the Walking Belt gets up to speed. Be sure to carefully step onto the walking belt.

-  **The belt will only move after a 3 second, audible beep countdown.**
- Always use the handlebars to step on or off the treadmill, or when the incline or speed change.**
- If the Sound has been muted, the Console will display the “AUDIO OFF” prompt for a few seconds.**
- To perform an emergency dismount, grab onto the Front or Side Handlebars and safely step onto the Side Foot Platforms. Bring the Walking Belt to a stop and carefully step off the machine.**

Note: Your treadmill comes equipped with a durable, high quality walking belt designed to provide many hours of reliable service. The walking belt on a treadmill that has not been operated for a length of time, either in factory packaging or after assembly, can exhibit a “thumping” noise when started. This is due to the belt taking on the curve of the front and rear rollers. This is a common occurrence and does not indicate a problem with your machine. After the treadmill has been used for a short period of time the thumping noise will discontinue. The amount of time will vary depending on the temperature and humidity of the environment where the treadmill is placed.

Power-Up / Idle Mode

The Console will enter Power-Up / Idle Mode if it is plugged into a power source, the Power Switch turned on, and the Safety Key is properly installed.

Note: If the Safety Key is not installed, the machine will allow the User to perform all activities except to activate the Walking Belt. The Console will display the reminder to insert the Safety Key (“ + SAFETY KEY”). Once the Safety key is installed, the START button will need to be pushed again to begin the selected Workout.

Auto Shut-Off (Sleep Mode)

If the Console does not receive any input in approximately 5 minutes, it will automatically shut off unless in Demonstration mode. The LCD display is off while in Sleep Mode.

Push any button to start (wake up) the Console. If your machine is in Demonstration mode, hold down the PAUSE/STOP button and Decrease button together for 3 seconds.

Note: The Console does not have an On/Off switch.

-  **To disconnect, turn all controls to the off position, then remove plug from outlet.**

Initial Setup

During the first power-up, the Console should be set up with the date, time, and the preferred units of measurement.

1. Date: Push the Increase/Decrease buttons to adjust the currently active value (flashing). Push the Left/Right buttons to change which segment is the currently active value (month / day / year).
2. Push OK to set.
3. Time: Push the Increase/Decrease buttons to adjust the currently active value (flashing). Push the Left/Right buttons to change which segment is the currently active value (AM or PM / hour / minute).
4. Push OK to set.
5. Units of Measurement: Push the Increase/Decrease buttons to adjust between “MILES” (Imperial English) or “KM” (metric).
6. Push OK to set. The Console goes to the Power-Up Mode screen.

Note: To adjust these selections, consult the “Console Set-Up Mode” section.

Quick Start (Manual) Program

The Quick Start (Manual) program lets you start a workout without entering any information.

During a Manual Workout, each column represents a 2 minute time period. The active column will advance across the screen every 2 minutes. If the workout lasts for more than 32 minutes, the active column is fixed on the farthest column on the right and pushes the previous columns off the display.

1. Stand on the Side Foot Support Platforms.
2. Push the User button to select the correct User profile. If you do not have a User profile set up, you can select a User profile that has no customized data (default values only).
3. Push the START button to start the Manual program.
Note: The Safety Key must be installed for a workout to begin. If not installed, the Console will display " + SAFETY KEY". The Console will display "RAMPING UP" as the Walking Belt gets up to speed.
4. To change the Incline or Speed level, push the appropriate Increase or Decrease buttons. The time will count up from 00:00.
Note: The maximum time for a Quick Start workout is 9 hours, 59 minutes and 59 seconds (9:59:59).
5. When done with your workout, push PAUSE/STOP to pause the workout. Push PAUSE/STOP again to end the workout.
Note: The workout results are recorded to the current User Profile.

User Profiles

The Console lets you store and use 4 User profiles. The User profiles automatically record the workout results for each workout, and allow the workout data to be reviewed.

The User profile stores the following data:

- Name—up to 13 characters
- Weight
- Height
- Age
- Gender
- Lap Distance
- Scan
- Value (Customized Workout Display)

Select a User Profile

Every workout is saved to a User Profile. Be sure to select the proper User Profile before starting a workout. The last User that completed a workout will be the default user.

User Profiles are assigned the default values until they are customized by editing. Be sure to edit the User Profile for more accurate calorie and heart rate information.

Edit User Profile

1. From the Power-Up Mode screen, push the User buttons to select one of the User Profiles.
2. Push the OK button to select the User Profile.
3. The Console display shows the GOAL TRACK prompt. Push the Increase(▲) button.
4. The Console display shows the EDIT prompt and the current User Profile name. Push OK to start the Edit User Profile option.
To exit the User Profile options, push the PAUSE/STOP button and the console will go back to the Power-Up Mode screen.
5. The Console display shows the NAME prompt and the current User Profile name.

Note: The User name will be blank if this is the first edit. The name of a User Profile is limited to 13 characters.

The currently active segment will flash. Use the Increase/Decrease buttons to move through the alphabet and blank space (found between A and Z). To set each segment, use the Left(◀) or Right(▶) buttons to shift between segments.

Push the OK button to accept the displayed User name.

- To edit the other User data (WEIGHT, HEIGHT, AGE, GENDER), use the Increase/Decrease buttons to adjust, and push OK to set each entry.

Note: The User BMI is displayed on the HEIGHT prompt in the TIME display field.

The BMI Measurement is a useful tool that shows the relationship between weight and height that is associated with body fat and health risk. The table below gives a general rating for the BMI score:

Underweight	Below 18.5
Normal	18.5 – 24.9
Overweight	25.0 – 29.9
Obesity	30.0 and above

Note: The rating may overestimate body fat in athletes and others who have a muscular build. It may also underestimate body fat in older persons and others who have lost muscle mass.

 **Contact your doctor for more information about Body Mass Index (BMI) and the weight that is appropriate for you. Use the values calculated or measured by the machine's computer for reference purposes only.**

- The Console display shows the LAP DISTANCE prompt. This option controls the length of distance for a LAP during a workout. Use the Increase/Decrease buttons to adjust the LAP distance value. The default is "0.25" miles (or 0.4 km).

Push the OK button to set the LAP distance value.

- The Console display shows the SCAN prompt. This option controls how the workout values are displayed during a workout. The "ON" setting allows the Console to automatically display, or scan, between the workout values every 4 seconds. The "OFF" setting allows the user to push the RIGHT or LEFT buttons to view the other workout values when desired.

The default is "ON".

Push the OK button to set how the workout values are displayed.

- The Console shows the workout display VALUE prompt. This option controls if a workout value is displayed during a workout. The "ON" setting allows the Console to display the workout value, an "OFF" setting disables the workout value during a workout.

The Console flashes the active workout value (either Time, Lap (Time), Distance, Lap (Count), Heart Rate, Calories, or Pace) and states the current setting: "VALUE - ON" or "VALUE - OFF". Push the Increase(▲) or Decrease(▼) buttons to change the current setting, and push the Left(◀) or Right(▶) buttons to shift the active workout value.

Note: The Incline and Speed workout values cannot be disabled.

The default is "VALUE - ON" for all workout values. When done with modifying which workout values are displayed, push the OK button to set the Console.

- The Console display shows the WIRELESS HR prompt. If you are using the Console speakers at their higher settings and / or using a larger sized personal electronic device, the Console may show Heart Rate interference. This option allows the Telemetry Heart Rate Receiver to be deactivated blocking the interference.

The display shows the current value setting: "ON" or "OFF". Push the Increase(▲) or Decrease(▼) buttons to change the value. The default is "ON".

Push the OK button to set the Telemetry Heart Rate Receiver to active.

- The Console will go to the Power-Up Mode screen with the user selected.

Reset a User Profile

- From the Power-Up Mode screen, push the User button to select one of the User Profiles.
- Push the OK button to select the User Profile.
- The Console display shows the GOAL TRACK prompt. Push the Decrease (▼) button to change the prompt.

Note: To exit the User Profile options, push the PAUSE/STOP button and the console will go back to the Power-Up Mode screen.

4. The Console display shows the RESET prompt and the current User Profile name. Push OK to start the Reset User Profile option.
5. The Console will now confirm the request to reset the User profile (the default selection is 'RESET - NO'). Push the Increase(▲) or Decrease(▼) buttons to adjust the selection.
6. Push OK to make your selection.
7. The Console will go to the Power-Up Mode screen.

Changing Incline Levels

Push the Incline Level Increase(▲) or Decrease(▼) buttons to change the incline angle of the Deck at any time with the Safety Key installed. To rapidly change the incline level push the desired Pre-Set Incline Button, and then the Incline Enter Button. The Deck will adjust to the selected incline level.

Note: After a Pre-Set Incline Button is pushed, the Incline Enter Button must be pushed within 12 seconds.

! Be sure the area below the machine is clear before lowering the Deck. Fully lower the Deck after each workout.

Exercise on this machine requires coordination and balance. Be sure to anticipate that changes in belt speed and incline angle of deck can occur during workouts, and be attentive in order to avoid loss of balance and possible injury.

Be sure that the workout space you are utilizing has adequate height clearance, taking into consideration the height of the user and the maximum height of the fully inclined Deck.

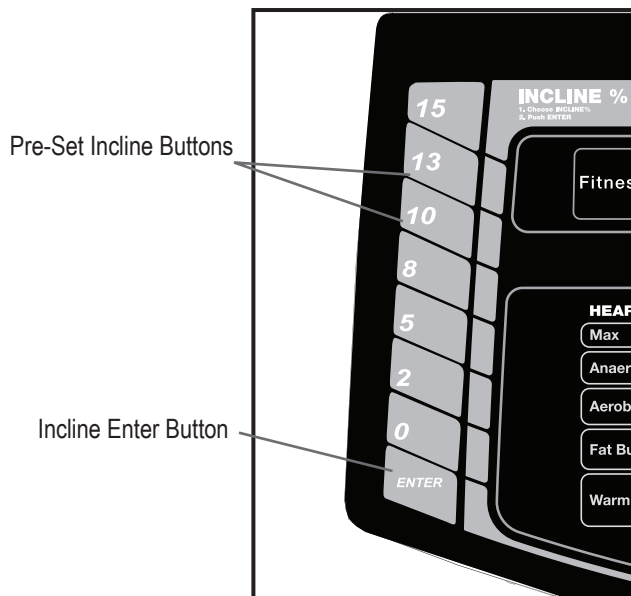

Changing Speed Levels

Push the Speed Level Increase(▲) or Decrease(▼) buttons to change the Belt Speed at any time in a workout program. To rapidly change the Speed level push the desired Pre-Set Speed Button, and then the Speed Enter Button. The Walking Belt will adjust to the desired speed.

Note: After a Pre-Set Speed Button is pushed, the Speed Enter Button must be pushed within 12 seconds.

Profile Programs

These programs feature different incline angles of the deck and belt speeds based on the maximum and minimum speed supplied by the user. The user can also manually adjust the incline and speed values at any time during a workout. The Profile Programs are organized into Categories (Quick Goal, Heart Health, Weight Control, Interval, Train, and Custom). Each Profile Program has 16 segments allowing for a variety of workouts.

! During a Profile Program, the Console will make an audio beep if the next segment of the workout has a change in Incline or Speed. Be prepared for changes in Incline and Speed with each segment change.

The currently selected Category will be active on the Console, with the first Profile Program Workout within that Category displayed. Use the Increase(▲) or Decrease(▼) buttons to select the desired Profile Program Workout from the Category of Workouts. At the end of the available Workouts for that Category, the More Options Guide (decrease arrow) will deactivate, telling the User they have reached the end of the Category.

QUICK GOAL

DISTANCE, TIME, CALORIES

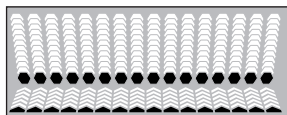

HEART HEALTH

HEALTHY- 55%, FAT BURN - 65%, AEROBIC - 75%, ANAEROBIC - 85%

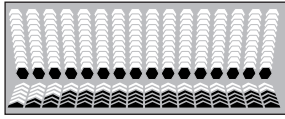

WEIGHT CONTROL

FAT BURN 1

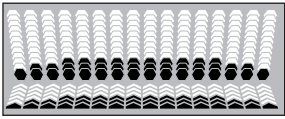

FAT BURN 2

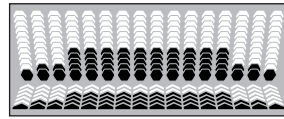

SPEED BURN

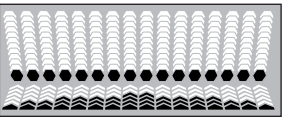

INCLINE BURN

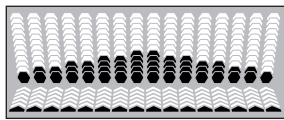

DUAL BURN

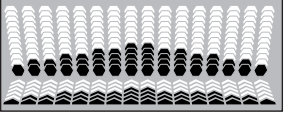

INTERVAL

INTERVAL-INC (Incline)

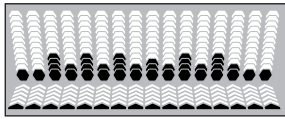

INTERVAL-SPD (Speed)

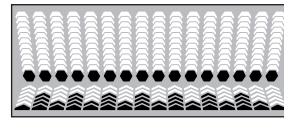

INTERVAL-DUAL (Incline and Speed)

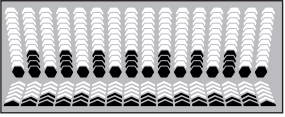

TRAIN

BOOT CAMP

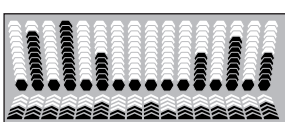

ENDURANCE

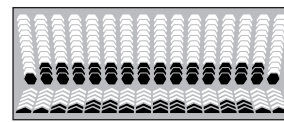

PERFORMANCE

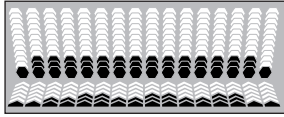

1 MILE PACER, 5K PACER, 10K PACER

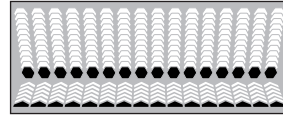

CUSTOM

HR (Heart Rate) TARGET

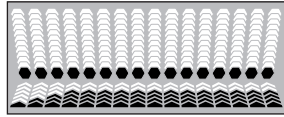

CUSTOM-SPD (Speed)

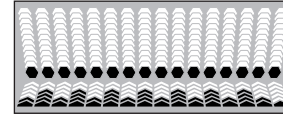

CUSTOM-INC (Incline)

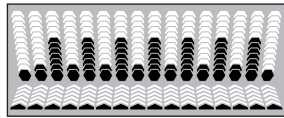

USER DEFINED

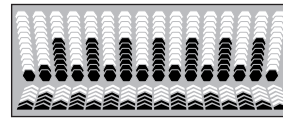

Workout Profile and Goal Program

The Console lets you select the Profile Program and type of Goal for your workout (Distance, Time or Calories), and set the Goal value.

Note: For certain Profile Programs, the Goal can not be adjusted (example: the 5K Pacer workout has a Distance Goal of 5K).

1. Stand on the Side Foot Support Platforms.
2. Push the User button to select the desired User profile.
3. Push the Programs buttons to select a Category of Workout.
4. Push the Increase(▲) or Decrease(▼) buttons to select a Profile Workout, and push OK.

If the selected Workout is Heart Rate Target, the Console will request the desired Beats Per Minute (BPM) for the Workout. Use the Increase(▲) or Decrease(▼) buttons to adjust, and push OK.

If the selected Workout Program has Incline and/or Speed Profile customization, the Console will prompt, "EDIT INCLINE" screen. Push the Increase(▲) or Decrease(▼) buttons to change the current setting, and push the Left(◀) or Right(▶) buttons to shift the active Profile segment. Push OK to accept the Incline Profile.

Note: The "EDIT SPEED" screen operates the same way.

5. Use the Increase(▲) or Decrease(▼) buttons to adjust the Minimum Speed of the Belt, and push OK. The Profile Program will adjust so the Minimum Speed value is the lowest Speed of the Profile Program when accepted.
6. Use the Increase(▲) or Decrease(▼) buttons to adjust the Maximum Speed of the Belt, and push OK. The Profile Program will adjust so the Maximum Speed value is the highest Speed of the Profile Program when accepted.

⚠ During a Workout, the User can directly adjust the speed of the belt above the Maximum Speed setting if desired, by using the Increase(▲) button.

7. Use the Increase(▲) or Decrease(▼) buttons to select a type of Goal (Distance, Time or Calories), and push OK.
8. Use the Increase(▲) or Decrease(▼) buttons to adjust the workout value, and push OK.
9. The Console will display the "READY ?" prompt.
10. Push START to begin the goal-oriented workout. The workout will begin after a three second, audible countdown.

Note: The Console will display "RAMPING UP" as the Walking Belt gets up to speed.

Heart Rate Control Workout Programs

The Heart Rate Control programs let you set a heart rate goal for your workout. The program monitors your heart rate in beats per minute (BPM) from the Contact Heart Rate (CHR) sensors on the machine or from a Heart Rate Monitor (HRM) chest strap, and adjusts the incline during a workout to keep your heart rate in the selected zone.

Note: The console must be able to read the heart rate information from the CHR sensors or HRM for the Heart Rate Control program to work correctly.

The Target Heart Rate programs use your age and other User information to set the Heart Rate Zone values for your workout. The console display then gives prompts for you to set up your workout:

1. Push the PROGRAMS button until the HEART HEALTH Category is selected.
2. Push the Increase(▲) or Decrease(▼) buttons to select the percentage of maximum heart rate: HEALTHY 55%, FAT BURN 65%, AEROBIC 75%, ANAEROBIC 85%.

⚠ Consult a physician before you start an exercise program. Stop exercising if you feel pain or tightness in your chest, become short of breath, or feel faint. Contact your doctor before you use the machine again. Use the values calculated or measured by the machine's computer for reference purposes only. The heart rate displayed on the console is an approximation and should be used for reference only.

3. Push the Increase(▲) or Decrease(▼) buttons to set the Minimum Speed, and push OK.
4. Push the Increase(▲) or Decrease(▼) buttons to set the Maximum Speed, and push OK.
5. Push the Increase(▲) or Decrease(▼) buttons to select the Goal type, and push OK.
6. Push the Increase(▲) or Decrease(▼) buttons to set the goal value for the workout, and push OK.

Note: Be sure to allow time for your heart rate to reach the desired heart rate zone when setting the goal. The Console will display the heart rate value based on the current User settings.

7. Push START to begin the workout.

A User can also set a Heart Rate Target value by selecting the HR TARGET program in the CUSTOM Category. The Console will adjust the incline during a workout to keep the User in the desired Heart Rate zone.

1. Push the PROGRAMS button until the CUSTOM Category is selected.
2. The Console shows the HR TARGET workout. Push OK.
3. Push the Increase(▲) or Decrease(▼) buttons to set the Heart Rate (HR) value for the workout, and push OK.
4. Push the Increase(▲) or Decrease(▼) buttons to set the Minimum Speed, and push OK.
5. Push the Increase(▲) or Decrease(▼) buttons to set the Maximum Speed, and push OK.
6. Push the Increase(▲) or Decrease(▼) buttons to select the Goal type, and push OK.
7. Push the Increase(▲) or Decrease(▼) buttons to set the goal value for the workout, and push OK.

Note: Be sure to allow time for your heart rate to reach the desired heart rate zone when setting the goal. The Console will display the heart rate value based on the current User settings.

8. Push START to begin the workout.

Compare Pacer Displays

The Compare Pacer Displays allow a User to focus, or train, on a set program and distance, and see how they compare against past workouts while doing a workout. The average, or best, past workout with the same distance goal are the pacers for the currently selected workout.



The User Placement Display shows the User where they are in relation to the pacer, with a time value and an UP arrow (in front) or DOWN arrow (behind the pacer).

The User Indicator Lights across the top of the Console quickly show the location of the User in relation to the pacer. The Pacer Icon (center of the User Indicator Lights) is the placement of the pacer, the Indicator Light is the User. The time difference between the User and the pacer is shown by which User Indicator Light is active (see the time scale below).



Note: The values presented during the first workout are based on the default pace value of 12 minutes per mile.

When a workout is started, the Average Pacer will be active. To change the pacer during a workout, push the COMPARE button. The pacer will shift to the Best Pacer, and the User Placement Window and appropriate User Indicator Light will adjust. If the COMPARE button is pushed again, the feature is Off, and the User Placement Display and Indicator Light will be deactivated.

Note: When the distance goal for the program is changed, it is a shift in the training focus of the program. The compare display will use the default values until a workout with the new distance goal is completed.

During a Pacer workout (1 Mile Pacer, 5k Pacer, 10k Pacer), the User inputs the time it will take for the pacer to complete the workout. The User Placement Window does not have an off option during a Pacer workout. The Compare button shifts the pacer value from Input Pace, Average, or Best.

Fitness Score Display

The Fitness Score is based on an estimate of the User's VO2 Max and calorie burn over their last five workouts.

VO2 Max estimates are calculated using performance data (time, distance and average heart rate or an estimate of average heart rate if that data is unavailable). VO2 Max is the maximal oxygen consumption of the aerobic physical fitness of the individual, and is a determinant of the endurance capacity of the User during prolonged exercise. (V = Volume, O2 = Oxygen, and Max = maximum rate).



For every workout completed that is longer than 10 minutes or a mile (1.6 km) in distance, the Console will apply those workout values toward your Fitness Score. This value is displayed on the Fitness Score Display area of the Console.

Note: Using a Heart Rate Chest Strap provides the most accurate information to calculate the Fitness Score. A Fitness Score is provided when a minimum of 10 minutes or 1 mile (1.6 km) of distance is done during a workout. If no heart rate is supplied, an approximation based on the User Profile will be used to calculate the score.

The Fitness Score may change only slightly for a User that performs the same length of workout at a similar intensity level. However, if that same User were to increase intensity over the same length of a workout, their score would increase. Since the score is based on VO2 Max (estimated), even a small score increase shows a significant shift in the User's fitness level.

Note: A User's score may drop slightly if fatigue is present. With the proper combination of exercise and rest, a User's Fitness Score will rise in a similar way to their VO2 Max. This will also be reflected in their ability to perform longer or faster workouts. Fitness Scores should only be compared to your previous scores and not to other User Profiles.

Pausing or Stopping

The Console will go into Pause Mode if the user pushes PAUSE/STOP during a workout.

1. Push the PAUSE/STOP button to pause your workout. The Console will display " PAUSED ".
2. To continue your workout, push the START button.

To stop the workout, push the PAUSE/STOP button. The Console will go into Results / Cool Down mode.

User Fitness Level Based on Fitness Score

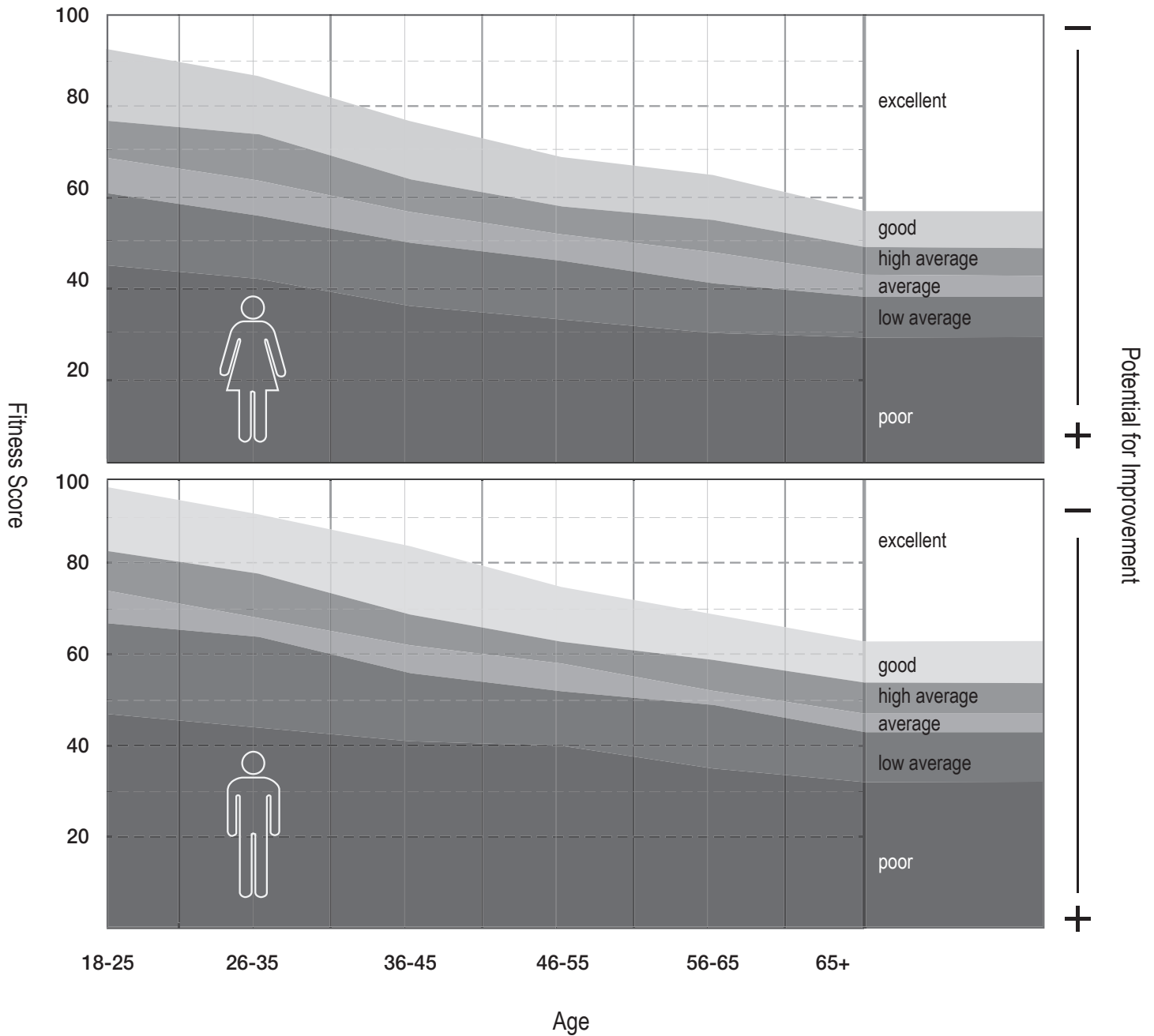

Results / Cool Down Mode

All workouts except Quick Start and the Heart Rate Control programs have a 3-minute Cool Down period. During this Cool Down period, the Console shows the Workout Results. The Console will cycle through the workout results every 4 seconds.

During the Cool Down period, the speed of the walking belt will adjust to 2 mph (3.2 km/h) and the incline setting will adjust to zero. The User can adjust the belt speed and deck incline during the Cool Down period.

Push PAUSE/STOP to end the Results / Cool Down period and go back to Power-Up Mode. If there is no input to the Console for 5 minutes, the Console automatically goes into Sleep Mode.

GOAL TRACK Statistics (and Achievements)

The statistics from every workout are recorded to a User Profile.

To view the GOAL TRACK statistics of a User Profile:

1. From the Power-Up screen, push the User button to select a User Profile.
2. Push the OK button to select the User Profile.
3. The Console display shows the GOAL TRACK prompt.

Note: To exit the User Profile options, push the PAUSE/STOP button and the console will go back to the Power-Up Mode screen.

4. Push the OK button. The Console will display the “LONGEST WORKOUT”, the workout values and activate the corresponding Achievement light. After 4 seconds, the Console will display the name of the workout, and then the date it was performed (except for “LAST 7 DAYS” and “LAST 30 DAYS”).

Note: To exit the GOAL TRACK statistics, push the PAUSE/STOP button and the console will go back to the Power-Up Mode screen.

5. Push the Decrease(▼) button to move to the next GOAL TRACK statistic, “CALORIE RECORD”. The Console will display the workout results with the most Calories value. The Console will cycle between the workout results, the name of the workout profile, and the date of the workout every 4 seconds. Use the Left(◀) or Right(▶) buttons to force the cycle between the workout results.
6. Push the Decrease(▼) button to move to “LAST 30 DAYS”. The Console will display the total values for the previous thirty days. The Console will cycle between the workout results every 4 seconds. Use the Left(◀) or Right(▶) buttons to force the cycle between the workout results.
7. Push the Decrease(▼) button to move to the “LAST 7 DAYS”. The Console will display the calories burned on the display (50 calories per segment) for the previous seven days, along with the workout value totals. The Console will cycle between the workout results every 4 seconds. Use the Left(◀) or Right(▶) buttons to force the cycle between the workout results.
8. Push the Decrease(▼) button to move to the “LAST WORKOUT”. The Console will display the workout values from the last workout. The Console will cycle between the workout results, the name of the workout profile, and the date of the workout every 4 seconds. Use the Left(◀) or Right(▶) buttons to force the cycle between the workout results.
9. When done viewing workout statistics, push the PAUSE/STOP button. The Console will display the Power-Up Mode screen.

When a User performs a workout that surpasses the “LONGEST WORKOUT” or “CALORIE RECORD” of the previous workouts, the Console will congratulate with an audible sound and tell the User the new achievement. The corresponding Achievement Indicator Light will also be active.

The Console Setup Mode lets you control the sound settings (on/off), adjust the date and time, or see maintenance statistics (Total Run Hours and Software Version– for service technician use only).

1. Hold down the PAUSE/STOP button and Right button together for 3 seconds while in the Power-Up Mode to go into the Console Setup Mode.

Note: Push PAUSE/STOP to exit the Console Setup Mode and return to the Power-Up Mode screen.

2. The Console display shows the Date prompt with the current setting. To change, push the Increase/Decrease buttons to adjust the currently active value (flashing). Push the Left/Right buttons to change which segment is the currently active value (month / day / year).
3. Push OK to set.
4. The Console display shows the Time prompt with the current setting. Push the Increase/Decrease buttons to adjust the currently active value (flashing). Push the Left/Right buttons to change which segment is the currently active value (AM or PM / hour / minute).
5. Push OK to set.
6. The Console display shows the UNITS prompt with the current setting. Push the Increase/Decrease buttons to change between “MILES” and “KM”.
7. Push OK to set.
8. The Console display shows the Sound Settings prompt with the current setting. Push the Increase/Decrease buttons to change between “ON” and “OFF”.



If the Sound has been muted, the Console will display the “AUDIO OFF” prompt before a Workout starts as a reminder.

9. Push OK to set.
10. The Console display shows the TOTAL RUN HOURS for the machine.
11. For the next prompt, push the OK button.
12. The Console display shows the BLE FW UPDATE prompt.

Note: If you have an update for the Bluetooth® Low Energy (also called Bluetooth® Smart) system, insert the USB Flash Drive with the update file into the Console. Push the Increase/Decrease buttons to select the “CONFIRM-YES” option, and push OK.

The Console will display “SAVING”, and then “REMOVE USB” when it is safe to remove the USB Flash Drive.

13. For the next prompt, push the OK button.
14. The Console display shows the Software Version code.
15. For the next prompt, push the OK button.
16. The Console display shows the LOG prompt.
17. For the next prompt, push the OK button.
18. The Console will display the Power-Up Mode screen.

Maintenance

Read all maintenance instructions fully before you start any repair work. In some conditions, an assistant is required to do the necessary tasks.

! Equipment must be regularly examined for damage and repairs. The owner is responsible to make sure that regular maintenance is done. Worn or damaged components must be repaired or replaced immediately. Only manufacturer supplied components can be used to maintain and repair the equipment.

If at any time the Warning labels become loose, unreadable or dislodged, replace the labels. If purchased in US/Canada, contact Customer Service for replacement labels. If purchased outside US/Canada, contact your local distributor for them.

! DANGER

To reduce the risk of electrical shock or unsupervised usage of the equipment, always unplug the power cord from the wall outlet and the machine and wait 5 minutes before cleaning, maintaining or repairing the machine. Place the power cord in a secure location.

Daily:

Before each use, examine the exercise machine for loose, broken, damaged, or worn parts. Do not use if found in this condition. Repair or replace all parts at the first sign of wear or damage, except for the Walking Deck. The Walking Deck is designed for wear on both sides of it. If only one side of the Walking Deck is worn, a replacement Deck is not required. It is recommended that a qualified service technician is used to flip the Walking Deck. After each workout, use a damp cloth to wipe your machine and Console free of moisture.

! With the Walking Deck lowered, if an edge of the Walking Belt can be seen, adjust it until the edge is not viewable.

Note: Avoid excessive moisture on the Console.

Weekly:

Check for smooth roller operation. Wipe the machine to remove dust, dirt, or grime.

! Do not remove the Motor Control Board (MCB) Cover. Dangerous voltages and moving parts are present. The components are serviceable only by approved service personnel or by following service procedures supplied by Nautilus, Inc.

Note: Do not use petroleum based products.

Monthly or after 20 hours:

Make sure all bolts and screws are tight. Tighten as necessary.

Quarterly:

Or after 25 hours—Lubricate the walking belt with a silicone-based lubricant.

! Silicone lubricant is not intended for human consumption. Keep out of reach of children. Store in a safe place.

Cleaning

! DANGER

To reduce the risk of electrical shock, always unplug the power cord and wait 5 minutes before cleaning, maintaining or repairing this machine.

Wipe the treadmill down after each use to keep the treadmill clean and dry. It may be necessary to use a mild detergent at times to remove all dirt and salt from the belt, painted parts and the display.

NOTICE: To prevent damage to the finish of the machine or Console, do not clean with a petroleum based solvent. Do not apply too much moisture to the Console.

Adjusting the Belt Tension

If the walking belt starts to slip during use, it is necessary to adjust the tension. Your treadmill has tension bolts at the rear of the treadmill.

1. Make sure that the walking belt is stopped and the power switch is turned Off.

! Be sure not to touch a moving walking belt or step on the power cord. Keep bystanders and children away from the product you are servicing at all times.

2. Use a 6 mm hex key to turn the right and left belt adjustment bolts clockwise a 1/2 turn, first one bolt and then the other bolt.
3. After you adjust each side the 1/2 turn, start the belt and do a test to see if the belt stopped slipping. If the belt still slips, return to step 1 and repeat the procedure.

If you turn one side more than the other, the belt will move away from that side of the treadmill and may need realignment.

NOTICE: Too much tension on the belt causes unnecessary friction and wears the belt, motor and electronics.

4. Push PAUSE/STOP twice to stop the walking belt and end the Quick Start workout.

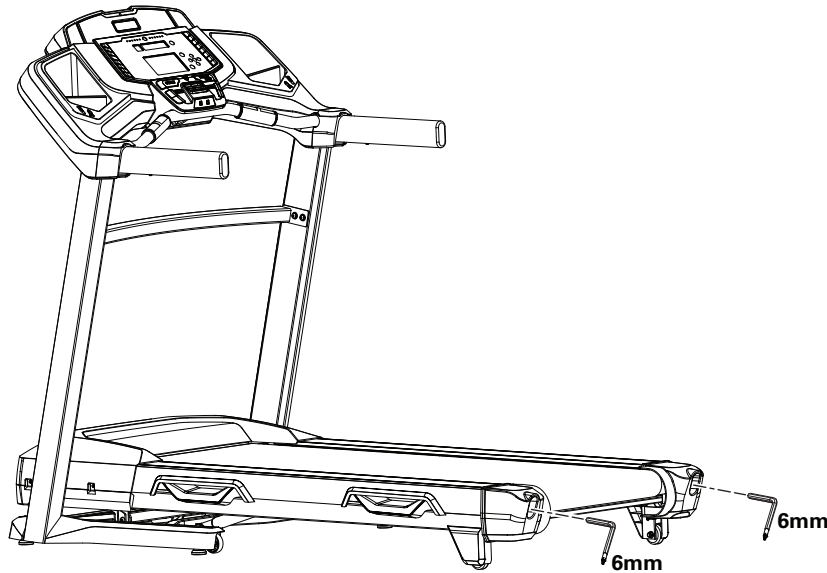

Aligning the Walking Belt

The walking belt should be centered on your treadmill at all times. Running style and a non-level surface can cause the belt to move off center. Minor adjustments to the 2 bolts at the rear of the treadmill are necessary when the belt is off center.

1. Push the START button to start the walking belt.

! Be sure not to touch a moving walking belt or step on the power cord. Keep bystanders and children away from the product you are servicing at all times.

2. Stand at the rear of the treadmill to see which direction the belt moves.
3. If the belt moves to the left, turn the left belt adjustment bolt 1/4 turn clockwise and the right belt adjustment bolt 1/4 turn counterclockwise.
If the belt moves to the right, turn the left adjustment bolt 1/4 turn counterclockwise and the right adjustment bolt 1/4 turn clockwise.
4. Monitor the path of the belt for approximately 2 minutes. Continue to adjust the bolts until the walking belt is centered.
5. Push PAUSE/STOP twice to stop the walking belt and end the Quick Start workout.

Lubricating the Walking Belt

Your treadmill is equipped with a low maintenance deck and belt system. The Walking Belt is pre-lubricated. Belt friction can affect the function and life of the machine. Lubricate the belt every 3 months or every 25 hours of use, whichever comes first. Even if the treadmill is not in use, silicone will dissipate and the belt will dry out. For the best results lubricate the deck periodically with 100% silicone lubricant, using the following instructions:

1. Turn off the power to the machine with the power switch.

- Unplug the treadmill fully from the wall outlet, and remove the power cord from the machine.

⚠ DANGER

To reduce the risk of electrical shock, always unplug the power cord and wait 5 minutes before cleaning, maintaining or repairing this machine. Place the power cord in a secure location.

Note: Make sure the treadmill is located on a surface that is easy to clean.

- Apply a few drops of the lubricant on the deck below the belt. Carefully lift the belt and apply a few drops of the lubricant the entire width of the belt. A very thin layer of silicone lubricant on the entire deck below the belt is desired.

NOTICE: Always use a 100% silicone lubricant. Do not use a degreaser like WD-40® as this could seriously impact performance. We can recommend that you use the following:

- 8300 Silicone Spray, available at most Hardware and Auto Parts stores.
- Lube-N-Walk® Treadmill Lubrication Kit, available from your local specialty fitness dealer or Nautilus, Inc.

⚠ Store silicone lubricant in a safe place. Keep out of reach of children. Silicone lubricant is not intended for human consumption.

- Manually rotate the belt 1/2 of the length of the belt and apply lubricant again.
- Connect the power cord back into the machine and then into the wall outlet.
- Turn on the power to the machine with the power switch.
- Stay to one side of your machine and start the belt at the slowest speed. Let the belt operate for approximately 15 seconds.

⚠ Be sure not to touch a moving walking belt or step on the power cord. Keep bystanders and children away from the product you are servicing at all times.

- Switch off your machine.
- Take care to clean up any excess lubricant from the deck.

⚠ To decrease the possibility of slipping, be sure the deck area is free from grease or oil. Clean off any excess oil from the machine surfaces.

Heart Rate Chest Strap Battery Replacement

The heart rate (HR) chest strap uses a CR2032 battery.

⚠ Do not perform this procedure outdoors or in moist or wet locations.

- Using a coin, loosen the slotted cover on the battery bay. Remove the cover and battery.
- When replacing the battery, insert it in the battery bay with the + symbol facing up.
- Reinstall the cover on the strap.
- Discard the old battery. Dispose of in accordance with local regulations and/or at approved recycling centers.
- Inspect your chest strap to ensure function.

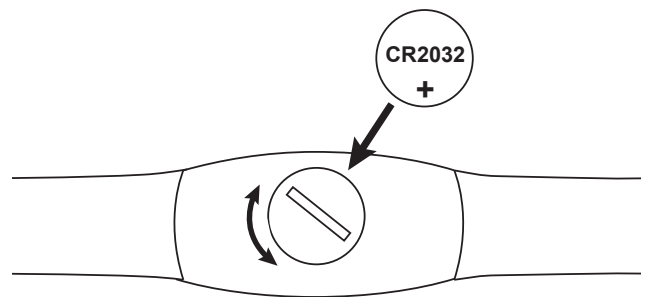

⚠ Do not use until the equipment has been fully assembled and inspected for correct performance in accordance with the Owner's Manual.

Maintenance Parts

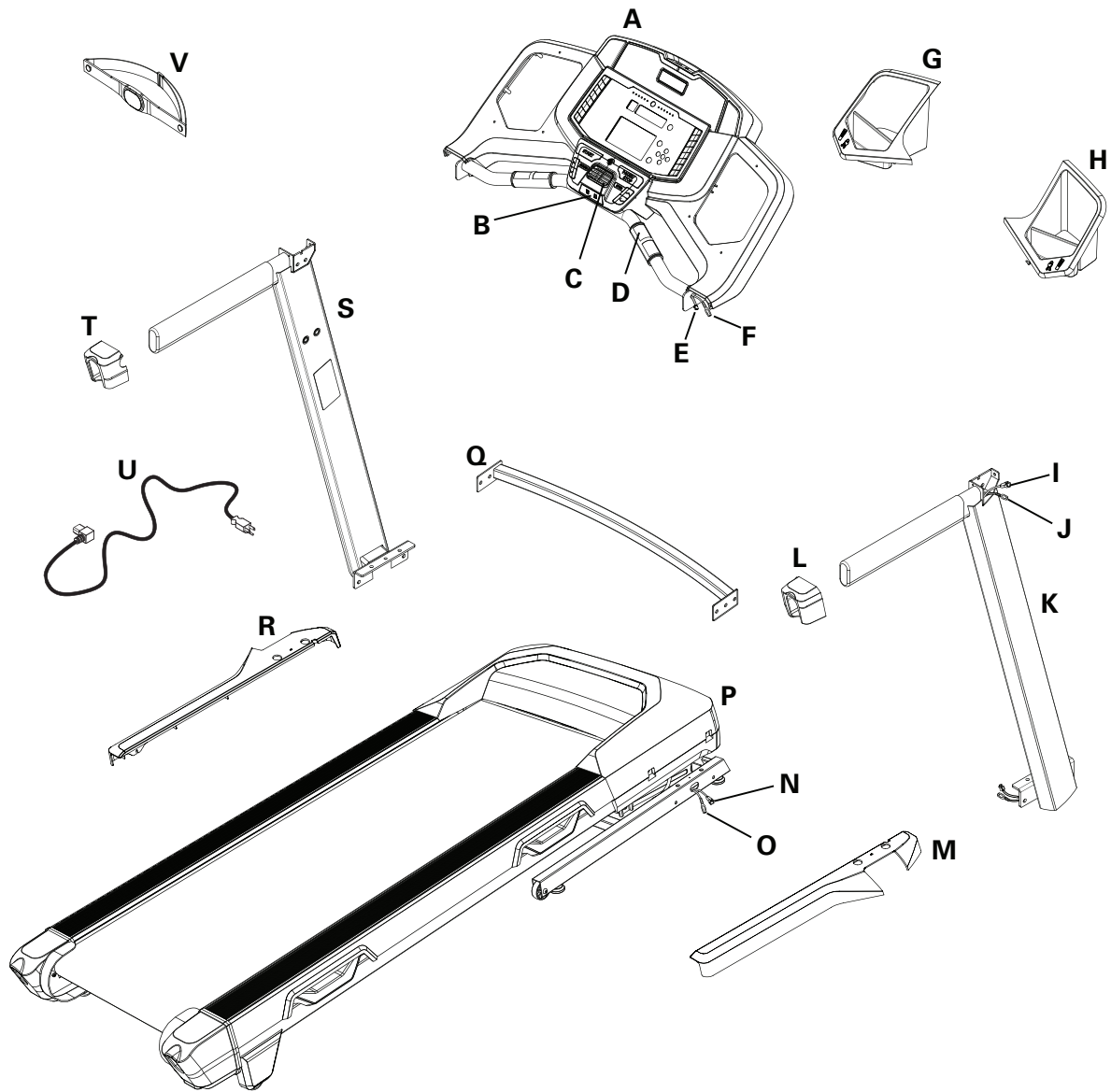

A	Console Assembly	I	Right Upright Cable (I/O)	Q	Crossbar
B	Safety Key Port	J	Right Upright Grounding Cable	R	Base Shroud, Left
C	Fan	K	Upright, Right	S	Upright, Left
D	Contact Heart Rate Sensor	L	Handlebar Shroud, Right	T	Handlebar Shroud, Left
E	Console Cable (I/O)	M	Base Shroud, Right	U	Power Cord
F	Console Grounding Cable	N	Base Cable (I/O)	V	Heart Rate Chest Strap
G	Cupholder, Left	O	Base Grounding Cable		
H	Cupholder, Right	P	Base Assembly		

Maintenance Parts (Frame)

Front

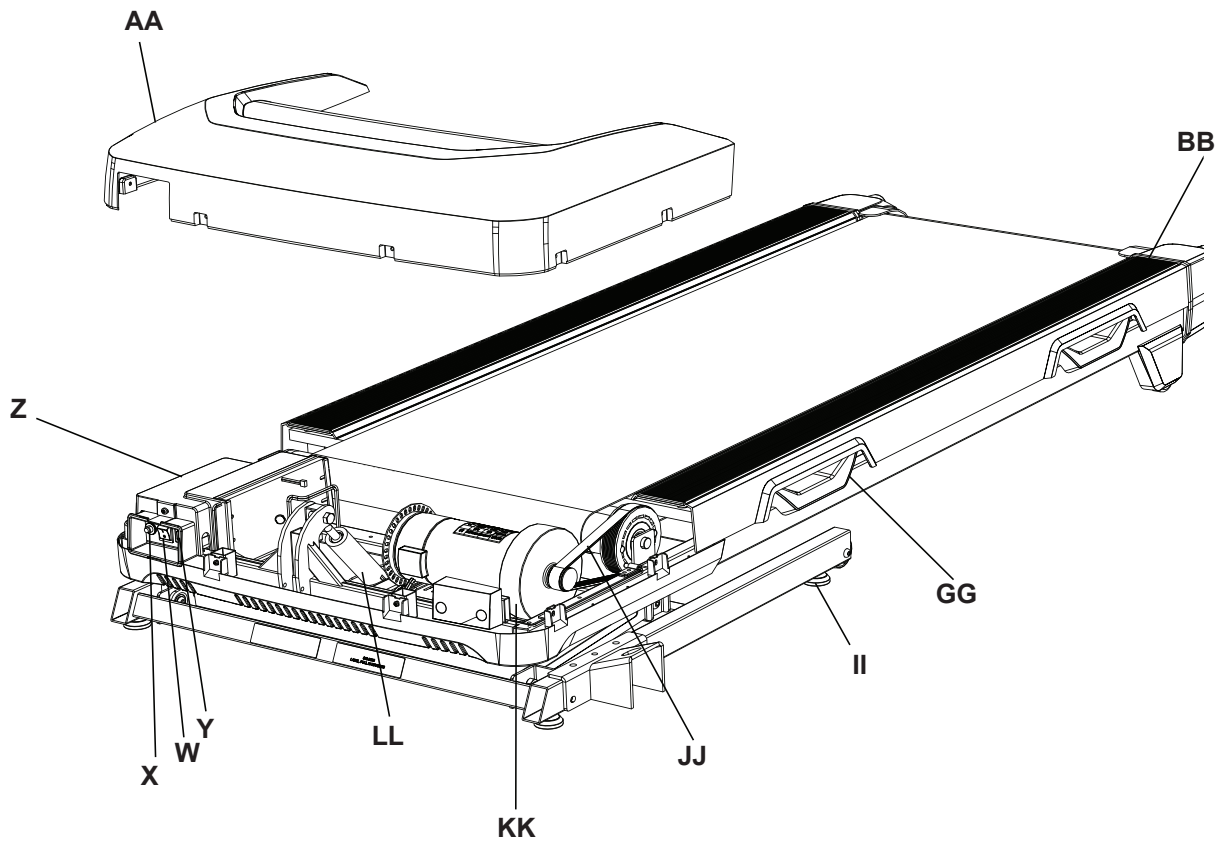

Back

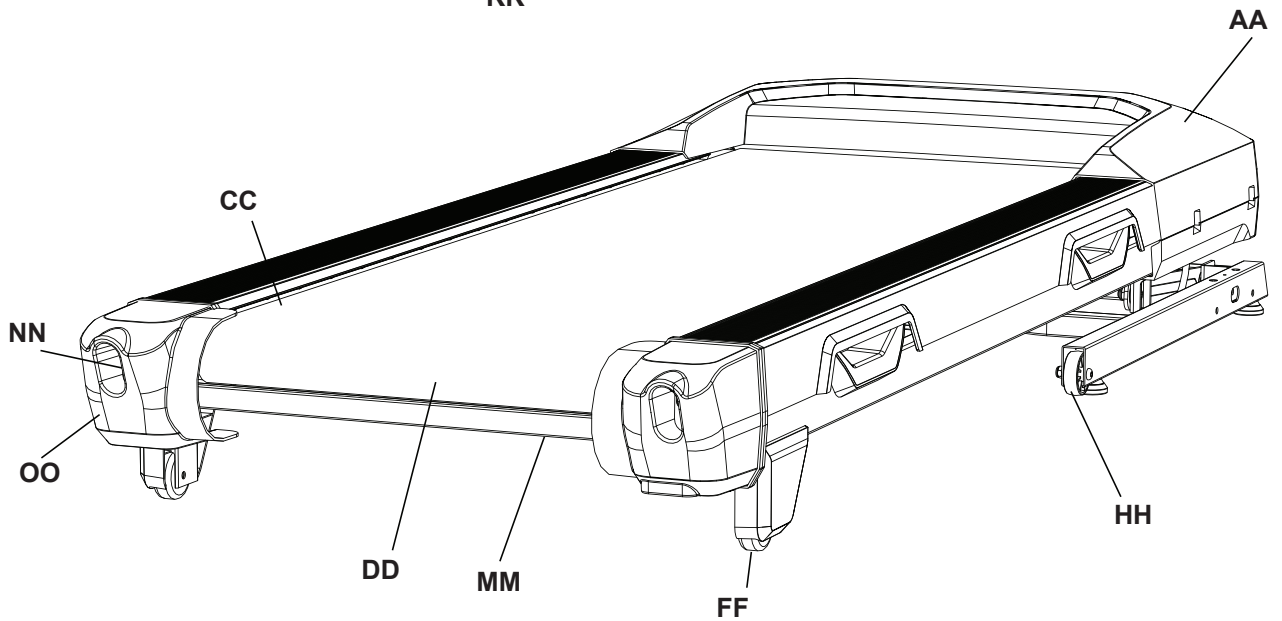

W	Power Switch	DD	Rear Roller	KK	Motor
X	Fuse	EE	Walking Deck	LL	Incline Adjuster
Y	Power Input	FF	Base Support	MM	Lift Handle
Z	Motor Control Board (MCB) Cover	GG	Deck Cushioners	NN	Belt Tensioner
AA	Motor Cover	HH	Transport Wheel	OO	Rear Roller Cover
BB	Side Foot Support Rails	II	Leveler		
CC	Walking Belt	JJ	Drive Belt		

Condition/Problem	Things to Check	Solution
No display/partial display/unit will not turn on	Check electrical (wall) outlet	Make sure unit is plugged into a functioning wall outlet. Test the outlet with a known functioning device such as a lamp.
	Check connection at front of unit	Connection should be secure and undamaged. Replace power cord or connection at unit if either are damaged.
	Check data cable integrity	All wires in cable should be intact. If any are visibly crimped or cut, replace cable.
	Check data cable connections/ orientation	Be sure cable is connected securely and oriented properly. Small latch on connector should line up and snap into place.
	Check console display for damage	Check for visual sign that console display is cracked or otherwise damaged. Replace Console if damaged.
	Console Display	If Console only has partial display and all connections are fine, replace the Console.
		If the above steps do not resolve the problem, contact Customer Service (if inside US/Canada) or your local distributor (if outside US/Canada).
Unit operates but Contact HR not displayed	Sensor grip	Be sure hands are centered on HR sensors. Hands must be kept still with relatively equal pressure applied to each side.
	Dry or calloused hands	Sensors may have difficulty with dried out or calloused hands. A conductive electrode cream (heart rate cream) can help make better conduct. These are available on the web or at medical or some larger fitness stores.
		If tests reveal no other issues, contact Customer Service (if inside US/Canada) or your local distributor (if outside US/Canada).
Unit operates but Telemetric HR not displayed	Chest Strap	Strap should be "POLAR®" compatible and uncoded. Make sure strap is directly against skin and contact area is wet. Make sure the transmitter has the curve oriented upward.
	Chest Strap Batteries	If strap has replaceable batteries, install new batteries.
	Check User Profile	Select the Edit User Profile option for the User Profile. Go to the WIRELESS HR setting and make sure that the current value is set to ON.
	Interference	Try moving unit away from sources of interference (TV, Microwave, etc).
	Replace Chest Strap	If interference is eliminated and HR does not function, replace strap.
	Replace Console	If HR still does not function, contact Customer Service (if inside US/Canada) or your local distributor (if outside US/Canada).
Speed display is not accurate	Display set to wrong unit of measure. (English/Metric)	Change display to show correct units.
Console shuts off (enters sleep mode) while in use	Check electrical (wall) outlet	Make sure unit is plugged into a functioning wall outlet. Test the outlet with a known functioning device such as a lamp.
	Check connection at front of unit	Connection should be secure and undamaged. Replace power cord or connection at unit if either are damaged.
	Check data cable integrity	All wires in the cable should be intact. If any are cut or crimped, replace cable.
	Check data cable connections/ orientation	Be sure cable is connected securely and oriented properly. Small latch on connector should line up and snap into place.
	Reset machine	Unplug unit from electrical outlet for 3 minutes. Reconnect to outlet.
		If the above steps do not resolve the problem, contact Customer Service (if inside US/Canada) or your local distributor (if outside US/Canada).
Console continuously cycles through program screens	Console is in demonstration mode	Hold down the PAUSE/STOP button and Decrease button together for 3 seconds.

Condition/Problem	Things to Check	Solution
Fan will not turn on or will not turn off	Reset machine	Unplug unit from electrical outlet for 5 minutes. Reconnect to outlet.
Fan will not turn on, but Console operates	Check for blockage of fan	Unplug unit from electrical outlet for 5 minutes. Remove material from fan. If necessary, detach the Console to help with removal. Replace the Console if unable to remove blockage.
Unit rocks/does not sit level	Check leveler adjustment	Adjust levelers until machine is level.
	Check surface under unit	Adjustment may not be able to compensate for extremely uneven surfaces. Move machine to level area.
Thumping sound when belt operates	Walking belt	Walking belt needs to be used for wear in period. Sound will go away after the wear in period.
Walking belt not aligned	Machine leveling	Make sure the machine is level. Refer to the procedure for leveling the machine in this manual.
	Walking belt tension and alignment	Make sure the walking belt is centered and tension is correct. Refer to the procedures for adjusting tension and aligning the belt in this manual.
Motor sounds strained	Silicone lubrication on walking belt	Apply silicone to the inner surface of the walking belt. Refer to the belt lubrication procedure in this manual.
Hesitation or walking belt slips when in use	Belt tension	Adjust the belt tension at the rear of the machine. Refer to the procedure for adjusting belt tension in this manual.
Belt stops moving while in use	Safety key	Plug Safety Key into Console. (See Emergency Stop Procedure in the Important Safety Instructions section.)
	Motor overload	Unit may be overloaded and draw too much current, which causes power to turn off to protect motor. Refer to maintenance schedule for belt lubrication. Make sure the walking belt tension is correct, and start unit again.
		If the above steps do not resolve the problem, contact Customer Service (if inside US/Canada) or your local distributor (if outside US/Canada).
Workout results will not sync with Bluetooth® enabled device	Current console mode	Machine must be in Idle Mode to sync. Push the PAUSE/STOP button until the Power-Up Mode screen is displayed.
	Total time of workout	A workout must be longer than 1 minute to be saved and posted by the Console.
	Fitness machine	Unplug unit from electrical outlet for 5 minutes. Reconnect to outlet.
	Bluetooth® enabled device	Consult your device to be sure that the Bluetooth® wireless feature has been enabled on it.
	Fitness App	Review Specifications of Fitness App and confirm your device is compatible.
		Contact appsupport@nautilus.com (if inside US/Canada) or your local distributor (if outside US/Canada) for further assistance.

Introduction and Overview

Welcome to the Bowflex™ Body Weight Loss Guide. This guide is designed to be used with your Bowflex™ equipment and will help you:

- Lose weight and get lean
- Improve your health and wellness
- Increase your energy and vitality

⚠ Consult a physician before you start an exercise program or a new health and diet plan. Stop exercising if you feel pain or tightness in your chest, become short of breath, or feel faint. Contact your doctor before you use the machine again. Use the values calculated or measured by the machine's computer for reference purposes only. The heart rate displayed on the console is an approximation and should be used for reference only.

By focusing on the main three elements of the Bowflex™ Body Weight Loss Guide- quality, balance, and consistency- you'll be able to reach and maintain your weight loss and fitness goals for the next six weeks and beyond.

- **Quality** – The emphasis of this plan is on eating more whole foods and getting the most nutrients from your calories as possible. Making the majority of your diet from foods that have a single ingredient (for example fruits, vegetables, fish, lean protein, eggs, beans, nuts, and whole grains) provides the vitamins, minerals, fiber, protein, and healthy fats your body needs.
- **Balance** – Each of the meals and snacks in this guide have a source of fiber or smart carbohydrate, protein, and healthy fat to keep your energy levels consistent throughout the day to fuel your workouts. By having this balance you'll feel fuller longer, which is critical to weight loss success.
- **Consistency** – Getting about the same number of calories each day is important for your metabolism and your mindset. If you overdo it one day, don't try to make up for it the next day by not eating or cutting your calories drastically. Get right back on track by following this guide!

Results & Expectations

Results will vary depending on your age, starting weight, and exercise level but on average you may lose 1-3 lbs per week and experience increased energy levels.

5 Tips for Long-Term Success

1. **Keep a food log** including hunger levels and water intake. Free online food logs and mobile apps are available at www.myfitnesspal.com and www.loseit.com
2. **Weight and/or take measurements weekly** – no more and no less. Weighing weekly rather than daily or every other day is best. You'll track your progress and keep yourself in check without getting discouraged if the scale doesn't move for a few days. And remember, weight is just a number and it's influenced by muscle gain as well as fat loss. Feeling how your clothes fit can often be a better indicator of progress as your body adapts to exercise and nutrition changes.
3. **Measure portions** – To avoid portion creep, use measuring cups and spoons for grains (rice, pasta, cereal), beans, nuts, oils, and dairy. Use the Portion Sizes Guide for other foods.
4. **Plan ahead** – Make a meal plan for the week or log your food a day in advance. Planning sets you up for success, especially for social events and eating out.
5. **Practice your desired long-term habits** – It's easy to justify poor eating choices when you're only focused on the short term. Focus on the long term satisfaction of a slimmer, healthier you rather than the temporary gratification you'll get from splurging.

How to Use this Guide

- **Eat breakfast within 90 minutes of waking up and balance your meals and snacks throughout the day**
 - Don't go longer than 5-6 hours without eating
 - If you're not used to eating breakfast, start out small with a piece of fruit and have something else 1-2 hours later. Your body adapts to not eating breakfast, but as soon as you start eating early in the day and cutting back on dinner portions you'll notice your hunger will increase. This is a good sign your metabolism is working!
- **Mix and match meal options**
 - Select 1 option from the appropriate meal plan (male or female) for breakfast, lunch, and dinner, paying close attention to portion sizes
 - Select 1-2 snack options per day
 - You have the option to substitute one snack for one treat under 150 calories
 - Use the meal plan, sample options, and grocery list to create your own meals for more variety

- You can swap out any type of protein, vegetables or smart carbs for the suggested meal options. For example:
 - Turkey for tuna
 - Any fish or seafood for chicken
 - Cooked vegetables instead of salad
- **Eat your calories**
 - Cut out high calorie beverages like soda, juices, coffee drinks, and alcohol
 - Stick with water, unsweetened tea, and coffee. Aim for a minimum of 64oz (1.9 liters) of water per day to stay well hydrated
- **If you're still hungry after or in between meals:**
 - Have a glass of water and wait 15-20 minutes. Many times we mistake thirst (or even boredom!) for hunger. Wait out the initial urge to eat and sometimes it will pass.
 - If you're still hungry after waiting 15-20 minutes have a snack or mini-meal with fruit, vegetables, and protein.

If your goal is muscle gain or strength:

- Use the same meal plan but increase portion sizes in the same ratios to increase the total number of calories you eat every day. For example, increase portion sizes of protein and smart carbs at meals by 50%. Adding a snack is another option to meet your body's increased calorie needs in order to gain muscle and strength.
- Focus on post-workout nutrition by having one of your snacks within 30 minutes after you complete your workout. Make sure to have a combination of carbohydrates such as fruit with protein (yogurt, milk, or protein powder) to promote muscle growth and recovery. Chocolate milk is also a great option.

Meal Plan Overview

The female meal plan provides about 1400 calories, and the male plan provides about 1600 calories, of high quality nutrition to not only help you lose weight and feel great but get the most out of your calories. The vitamins, minerals, and antioxidants from eating mostly whole foods help support optimal health. These calorie levels will result in healthy weight loss for the majority of people. Keep in mind that everyone's metabolism is very different depending on age, height, weight, activity level, and genetics. Pay close attention to your weight, hunger levels, and energy and adjust your calories if needed.

Follow these guidelines if you're over 55:

- If you're over 55, you need fewer calories because your metabolism slows as you age. Stick with three meals with one optional snack per day.

Follow these guidelines if you're under 25:

- If you're under 25 you may need more calories. Add another snack if you feel low on energy or are extremely hungry.

Breakfast

Breakfast includes a smart carb, fruit, and a source of protein, which will also have fat. With a balance of carbohydrates and fiber from the smart carb and fruit combined with protein and fat, you'll energize your day and help control hunger levels throughout the day.

Snacks

Each snack is a balance of carbohydrates and protein to keep your blood sugar more consistent, which means you won't experience hunger and energy level spikes and drops.

This happens when you have a high carb-only snack like chips, candy, soda, crackers, or pretzels.

Lunch and Dinner

Lunch combines filling fiber from vegetables and smart carbs with a lean, or low-fat, protein. The healthy fat can come either from the protein added during cooking (nuts on a salad) or as a dressing or sauce (such as oil and vinegar salad dressing).



Here's an overview of what an ideal day looks like:
(See Portion Size Guide for proper serving sizes)

Breakfast

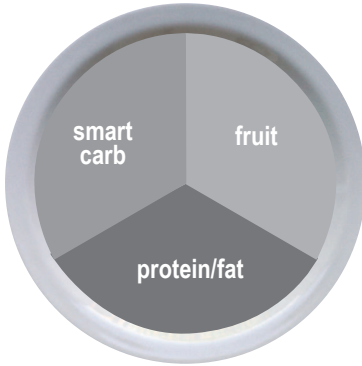

Snack #1

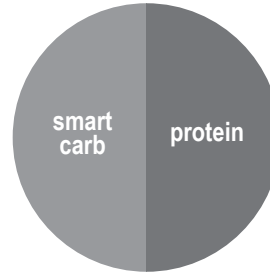

Lunch

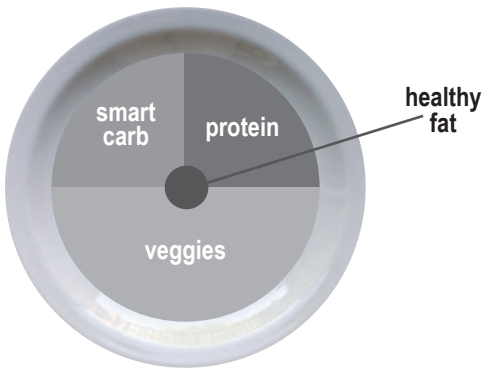

Snack #2

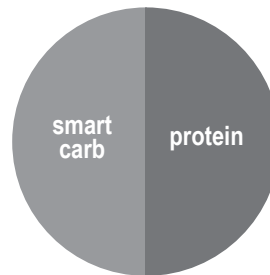

Dinner

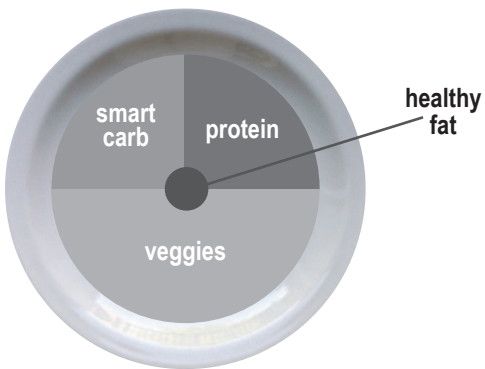

Breakfast Options	Fruit	Smart Carb	Protein/Fat
Fruit and Nut Oatmeal Cook plain oats in water. Top with fruit, nuts, milk, cinnamon, and honey.	Berries or banana	Plain oats (Regular or quick-cook)	Nuts and milk
Egg Muffin Cook egg/s. Toast bread and top with 1 slice of cheese, 1 slice of ham, and tomato.	Tomato	English muffin or sandwich thin	Egg, ham, and cheese
Yogurt Power Parfait Top yogurt with fruit. Sprinkle with 1 serving of nuts, 2-3 tbsp wheat germ, or ground flaxseed, 1 tbsp oats, and cinnamon.	Chopped fruit of your choice	Oats, wheat germ, and ground flaxseed	Plain non-fat Greek yogurt and nuts
On the Go PB & Apple Sandwich Toast bread. Spread on peanut butter, thin slices of ½ an apple, and 1 teaspoon of honey.	Sliced apple	Sandwich thin, bread, or bagel thin	Peanut butter

Lunch & Dinner Options	Lean Protein	Smart Carb	Veggies
Pork Loin, Sweet Potato & Green Beans	Grilled or baked pork loin	Baked Sweet Potato	Green Beans
Chicken Stir Fry Flavor with 2 tablespoon teriyaki sauce	Chicken breast or boneless skinless thigh	Brown or wild rice	Mixed stir fry vegetables (fresh or frozen)
Steak Tacos with Side Salad (3 for males, 2 for females) Top with salsa, cilantro, and sprinkle of shredded cheese	Flank or sirloin steak	Corn tortillas	Salad
Whole Wheat Pasta with Shrimp or Cannellini Beans & Marinara Sauce	Shrimp (frozen or fresh) or cannellini beans	Whole wheat pasta	Steamed broccoli
Bunless Burgers with Oven Fries, Corn, & Salad Grill burgers. Bake sliced potatoes on sprayed cookie sheet for 25-30 minutes @ 425°F.	93% lean ground beef or turkey	Oven baked fries	Corn on the cob + side salad
Tuna & Avocado Wrap with Vegetable Soup Use 3oz of tuna (1 can). Top with lettuce, tomato, avocado, and mustard.	Tuna	High-fiber wrap	Vegetable soup (homemade or low-sodium canned)



Snack Options	
Smart Carb	Protein
1 medium apple	10-15 almonds
Baby carrots	2 tbsp hummus
1 serving of crackers*	1 string cheese
Energy or protein bar with <200 calories*	

*See www.Bowflex.com/Resources for brand recommendations

Optional Treats

You have the choice of replacing Snack #2 with a 100-150 calorie treat. You can have an optional treat every day but for optimal health it is recommended to limit small splurges to 3-4 times per week. Use the approach that works best for you. Here are a few examples:

- ½ cup lowfat ice cream
- 1 small bag of baked potato chips
- 4oz of wine or 12oz light beer
- 3 cups of air-popped or light popcorn

Sample 3 Day Plan

Based on each of the meal options listed above, a typical 3 day plan could look like this:

	Day 1	Day 2	Day 3
Breakfast	Egg muffin	Power yogurt parfait	Fruit + nut oatmeal
Snack 1	Apple with almonds	Nut Thins® + string cheese	Baby carrots and hummus
Lunch	Tuna & avocado wrap with soup	Leftovers from dinner- day 1	Leftovers from dinner- day 2
Optional Snack 2 or Treat	½ cup ice cream bar	Energy bar	100 calorie bag of light popcorn
Dinner	Shrimp pasta	Chicken stir fry	Bunless burgers

Portion Size Guide

Each of the items listed are for one serving

MALE	FEMALE
PROTEIN	
2 eggs 5oz chicken, fish, lean meat, or tofu 2/3 cup beans or lentils* 1 cup greek yogurt* 1.5oz cheese*	1 egg 3oz chicken, fish, or lean meat 1/2 cup beans or lentils* 1/2 cup greek yogurt* 1.5oz cheese*
HEALTHY FAT	
2 Tblspn peanut or nut butter* 2 tspn olive, flax, or walnut oil 1/4 cup of nuts 1/3 medium avocado	1 tblspn peanut or nut butter* 1 tspn olive, flax or walnut oil 1/8 cup or 2 tablespoons of nuts (approx. 15 almonds) 1/4 medium avocado
SMART CARB	
1 cup cooked grains (1/2 cup raw): oats, brown rice, quinoa, pasta 1 medium sweet or regular potato 2 corn tortillas 1 slice of bread (or 2 light slices equaling 120 calories or less) 1 english muffin, sandwich thin, or high-fiber wrap	1/2 cup cooked (1/4 cup raw) grains 1/2 medium sweet potato or regular potato 2 corn tortillas 1 slice of bread (or 2 light slices equaling 120 calories or less) 1 english muffin, sandwich thin, or high-fiber wrap
FRUIT	
1 medium apple, orange, or pear 1 small banana (length of your hand) 1 cup berries or chopped fruit 1/4 cup dried fruit (fresh or frozen is optimal)	
Vegetables* You can have unlimited vegetables except for peas and corn; stick with 1/2 cup serving	
2 cups spinach or lettuce = 2 cupped hands 1 cup raw vegetables 1/2 cup cooked vegetables 6oz low sodium vegetable juice	
OPTIONAL TREATS	
1/2 cup lowfat ice cream 1 small bag of baked potato chips 1oz dark chocolate 4oz of wine or 12oz light beer 3 cups air-popped or light popcorn	

* some foods are a combination of protein and carbs or protein and fat



1 cup = baseball



1/2 cup = lightbulb



1 oz or 2 tbsp = golf ball

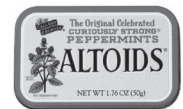

1/4 cup nuts = Altoids tin



3 oz chicken or meat = deck of cards



1 medium potato = computer mouse



1 medium piece of fruit = tennis ball



1 - 1/2 oz cheese = 3 dice

Grocery List

BREAD & GRAINS			
100% whole wheat bread Sprouted grain breads Light or whole wheat english muffins Sandwich or bagel thins Corn or low-carb whole wheat tortillas High-fiber wraps Plain oats: 1 minute or old fashioned Whole grains: brown rice, bulgar, barley, quinoa, couscous	Tips: Look for 100% whole wheat as the first ingredient. Look for 4g of fiber per slice or 5g per 2 slices of light or diet bread. Aim for bread with less than 100 calories per slice.		
DAIRY & DAIRY ALTERNATIVES	CRACKERS, SNACKS & ENERGY BARS		
Plain non-fat greek yogurt Kefir (yogurt like drink) Organic low-fat milk Enriched almond or soy milk Cheese: feta, parmesan, mozzarella, light havarti, provolone, swiss, string cheese, or single serving packages	<table border="1"> <tr> <td> Any unsalted nuts or seeds Air-popped or light popcorn Edamame in the pod </td> <td> Energy bars Crackers Hummus </td> </tr> </table>	Any unsalted nuts or seeds Air-popped or light popcorn Edamame in the pod	Energy bars Crackers Hummus
Any unsalted nuts or seeds Air-popped or light popcorn Edamame in the pod	Energy bars Crackers Hummus		
	Tips: Limit crackers, pretzels, and chips to 2-3 servings per week. Always pair with protein such as hummus, cheese, or nuts. Look for energy bars with less than 200 calories and 20g of sugar and at least 3g of protein and 3g of fiber. Look for crackers with less than 130 calories and 4g or less of fat per serving.		
MEAT, FISH, POULTRY & PROTEIN	FATS & OILS		
Wild game Salmon, halibut, tuna, tilapia, shrimp, catfish, scallops, or crab Pork loin, pork chops, or pork roast Chicken or turkey breast or thighs (no skin) Eggs and 100% egg whites Lean beef: sirloin, chuck, round, tenderloin, 93% lean (organic and grass fed is best) Canned salmon or tuna (in water) Nitrate-free, reduced sodium ham, turkey, chicken, or roast beef lunch-meat Any type of bean, dry or canned low-sodium varieties Tofu and tempeh	Avocado Olive, grapeseed, walnut, sesame, or flaxseed oil Butter/spreads: look for products free of trans fats and partially hydrogenated oils on the ingredient list.		
Tips: Look for "Choice" or "Select" cuts of meat rather than "Prime". Prime cuts are fattier. Limit intake of highly processed meat and imitation meat products like sausage, bacon, pepperoni, and hot dogs to once a week or less.	Tips: Light olive oil refers to the flavor, not the calorie content. Always measure oil and butter. Even if a fat is considered healthy, it's still very high in calories and portions need to be controlled.		
FROZEN FOODS	DRESSINGS, CONDIMENTS & SAUCES		
All vegetables without sauce All fruit Grains and grain medleys	Vinegars: rice, wine, balsamic All fresh or dried herbs and spices Mustard Salsa and chili sauce Marinara sauce with no high-fructose corn syrup Lemon and lime juice Bottled minced garlic and ginger Low-sodium soy sauce		
	Tips: Look for products free of MSG, added colors, and high fructose corn syrup. Look for sauces under 50 calories per serving. Avoid cream based sauces and dressings like ranch, bleu cheese, and alfredo.		

All fruits and vegetables, fresh and frozen, are great choices. Since every meal has one or both, your shopping cart should reflect this.



Keep It Going

Tips for continued weight loss and maintaining changes

- **Keep weighing yourself weekly**, even after you've reached your goal weight
- **Continue keeping a food log.** If you have your meal plan well-established, log your food every other week to keep yourself on track. Don't feel like you have to do it every day.
- **Prepare for plateaus.** The scale might not budge for a few weeks or even months after some initial weight loss. This is normal and to be expected. It's the body's natural process for adjusting to your new lower weight. Stay focused on your long-term goal, celebrate your successes and changes, and mix up your workouts to help overcome the plateau.
- **Calorie adjustments for maintaining weight loss.** Once you've reached your goal weight, you can increase your calories 100-200 per day as long as your activity level stays the same
- **Treat yourself.** Have a non-food reward for each goal you hit such as a massage, a new outfit, or an outing with friends and family
- **Use the resources below** to find new recipes, get expert advice, and support to stay motivated

Resources

Downloadable Resources from Bowflex™ Website (www.Bowflex.com/Resources)

- Grocery Shopping List for Fridge (Blank Form)
- 7 Day Meal Planning Form
- Additional Dinner Options
- Pre and Post Workout Fueling Guide

Questions & Support

- Ask questions, post suggestions, and connect with our online Bowflex™ Dietitian on the Bowflex Facebook page

Recipes

- www.wholeliving.com
- www.eatingwell.com
- www.whfoods.org
- www.livebetteramerica.org

Online food logs

- www.myfitnesspal.com
- www.loseit.com

Who Is Covered

This warranty is valid only to the original purchaser and is not transferable or applicable to any other person(s).

What Is Covered

Nautilus, Inc. warrants that this product is free from defects in materials and workmanship, when used for the purpose intended, under normal conditions, and provided it receives proper care and maintenance as described in the Product's Assembly and Owner's manual. This warranty is good only for authentic, original, legitimate machines manufactured by Nautilus, Inc. and sold through an authorized agent and used in the United States or Canada.

Terms

- Frame 10 years
- Drive Motor 10 years
- Mechanical parts 3 years
- Electronics 3 years
- Labor 1 year

(Labor support does not include the installation of replacement parts involved in the initial product assembly and preventative maintenance services.)

How Nautilus Will Support the Warranty

Throughout the terms of the warranty coverage, Nautilus, Inc. will repair any machine that proves to be defective in materials or workmanship. Nautilus reserves the right to replace the product in the event a repair is not possible. When Nautilus determines replacement is the correct remedy, Nautilus may apply a limited credit reimbursement toward another Nautilus, Inc. brand Product, at our discretion. This reimbursement may be prorated based on length of ownership. Nautilus, Inc. provides repair service within major metropolitan areas. Nautilus, Inc. reserves the right to charge the consumer for travel outside these areas. Nautilus, Inc. is not responsible for dealer labor or maintenance charges beyond the applicable warranty period(s) stated herein. Nautilus, Inc. reserves the right to substitute material, parts or products of equal or better quality if identical materials or products are not available at the time of service under this warranty. Any replacement of the product under the terms of the Warranty in no way extends the original Warranty period. Any limited credit reimbursement may be prorated based on length of ownership. THESE REMEDIES ARE THE EXCLUSIVE AND SOLE REMEDIES FOR ANY BREACH OF WARRANTY.

What You Must Do

- Retain appropriate and acceptable Proof of Purchase.
- Operate, maintain, and inspect the Product as specified in the Product Documentation (Assembly, Owner's Manuals, etc.).
- Product must be used exclusively for the purpose intended.
- Notify Nautilus within 30 days after detecting an issue with the Product.
- Install replacement parts or components in accordance with any Nautilus instructions.
- Perform diagnostic procedures with a trained Nautilus, Inc representative if requested.

What Is Not Covered

- Damage due to abuse, tampering or modification of the Product, failure to properly follow assembly instructions, maintenance instructions, or safety warnings as stated in the Product Documentation (Assembly, Owner's Manuals, etc), damage due to improper storage or the effect of environmental conditions such as moisture or weather, misuse, mishandling, accident, natural disasters, power surges.
- A machine placed or used in a commercial or institutional setting. This includes gyms, corporations, work places, clubs, fitness centers and any public or private entity that has a machine for use by its members, customers, employees or affiliates.
- Damage caused by exceeding maximum user weights as defined in the Product's Owner's manual or warning label.
- Damage due to normal usage and wear and tear.
- This warranty does not extend to any territories or countries outside the United States and Canada.

How to Obtain Service

For Products purchased directly from Nautilus, Inc. contact the Nautilus office listed on the Contacts page of the products Owner's manual. You may be required to return the defective component to a specified address for repair or inspection, at your expense. Standard ground shipping of any warranty replacement parts will be paid by Nautilus, Inc. For products purchased from a retailer, you may be asked to contact your retailer for warranty support.

Exclusions

The preceding warranties are the sole and exclusive express warranties made by Nautilus, Inc. They supersede any prior, contrary or additional representations, whether oral or written. No agent, representative, dealer, person or employee has the authority to alter or increase the obligations or limitations of this warranty. Any implied warranties, including the WARRANTY OF MERCHANTABILITY and any WARRANTY OF FITNESS FOR A PARTICULAR PURPOSE, are limited in duration to the term of the applicable express warranty provided above, whichever is longer. Some states do not allow limitations on how long an implied warranty lasts, so the above limitation may not apply to you.

Limitation of Remedies

EXCEPT AS OTHERWISE REQUIRED BY APPLICABLE LAW, THE PURCHASER'S EXCLUSIVE REMEDY IS LIMITED TO REPAIR OR REPLACEMENT OF ANY COMPONENT DEEMED BY NAUTILUS, INC. TO BE DEFECTIVE UNDER THE TERMS AND CONDITIONS STATED HEREIN. IN NO EVENT WILL NAUTILUS, INC. BE LIABLE FOR ANY SPECIAL, CONSEQUENTIAL, INCIDENTAL, INDIRECT OR ECONOMIC DAMAGES, REGARDLESS OF THE THEORY OF LIABILITY (INCLUDING, WITHOUT LIMITATION, PRODUCT LIABILITY, NEGLIGENCE OR OTHER TORT) OR FOR ANY LOST REVENUE, PROFIT, DATA, PRIVACY OR FOR ANY PUNITIVE DAMAGES ARISING OUT OF OR RELATED TO THE USE OF THE FITNESS MACHINE EVEN IF NAUTILUS, INC. HAS BEEN ADVISED OF THE POSSIBILITY OF SUCH DAMAGES. THIS EXCLUSION AND LIMITATION SHALL APPLY EVEN IF ANY REMEDY FAILS OF ITS ESSENTIAL PURPOSE. SOME STATES DO NOT ALLOW THE EXCLUSION OR LIMITATION OF CONSEQUENTIAL OR INCIDENTAL TYPE DAMAGES SO THE ABOVE LIMITATION MAY NOT APPLY TO YOU.

State Laws

This warranty gives you specific legal rights. You may also have other rights, which vary from state to state.

Expirations

If the warranty has expired, Nautilus, Inc. may assist with replacements or repairs to parts and labor, but there will be a charge for these services. Contact a Nautilus office for information on post-warranty parts and services. Nautilus does not guarantee availability of spare parts after expiration of warranty period.

International Purchases

If you purchased your machine outside of the United States consult your local distributor or dealer for warranty coverage.

